

#### FEATURES

- High Performance VCA, RMS-Level Detector, and three Opamps in one package
- Wide Dynamic Range: > 105 dB
- Low THD: < 0.09%
- Low Power: 7 mA typ.
- Surface-Mount Package
- 5 VDC Operation

#### APPLICATIONS

- Wireless microphone systems
- Wireless in-ear monitors
- Compressors and Limiters
- Gates
- De-Essers
- Duckers

#### Description

The THAT 4311 Low Power Dynamics Processor combines in a single IC all the active circuitry needed to construct a wide range of dynamics processors. The 4311 includes a high performance, voltage controlled amplifier, a log responding RMS-level sensor and three opamps, one of which is dedicated to the VCA, while the other two may be used for the signal path or control voltage processing.

The exponentially-controlled VCA provides two opposing-polarity, voltage sensitive control ports. Dynamic range exceeds 105 dB, and THD is typically 0.09% at 0dB gain. The RMS detector provides accurate RMS to DC conversion over an

80 dB dynamic range.

Though originally designed for use in microphone noise reduction systems, the 4311 is a useful building block in a number of analog signal processing applications. The combination of exponential VCA gain control and logarithmic detector response - "decibel-linear" response - simplifies the mathematics of designing the control paths of dynamics processors, making it easy to develop audio compressors, limiters, gates, expanders, de-essers, duckers, and the like. The high level of integration ensures excellent temperature tracking between the VCA and the detector, while minimizing the external parts count.

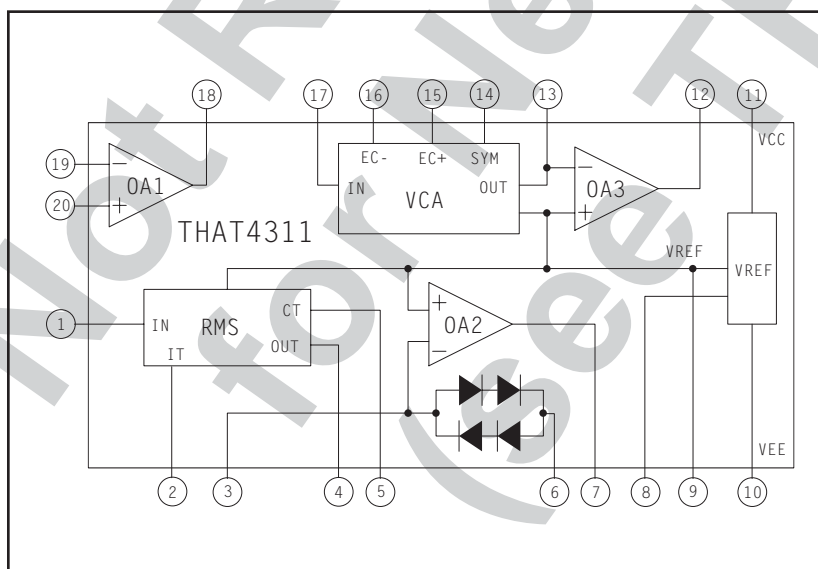

Figure 1. THAT 4311 equivalent block diagram

Pin Name	DMP20
RMS IN	1
IT (I <sub>TIME</sub> )	2
OA2 -IN	3
RMS OUT	4
CT (C <sub>TIME</sub> )	5
CLIP	6
OA2 OUT	7
CAP	8
VREF	9
VEE	10
VCC	11
OA3 OUT	12
VCA OUT	13
SYM	14
EC+	15
EC-	16
VCA IN	17
OA1 OUT	18
OA1 -IN	19
OA1 +IN	20

Table 1. THAT 4311 pin assignments

**SPECIFICATIONS<sup>1</sup>**

<b><u>Absolute Maximum Ratings (T<sub>A</sub> = 25°C)</u></b>			
Positive Supply Voltage (V <sub>CC</sub> )	+15 V	Power Dissipation (P <sub>D</sub> ) (T <sub>A</sub> = 75°C)	700 mW
Operating Temperature Range (T <sub>OP</sub> )	-20 to +70°C	Storage Temperature Range (T <sub>ST</sub> )	-40 to +125°C
Max ΔE <sub>C</sub> E <sub>C+</sub> - (E <sub>C-</sub> )	± 1V		

<b><u>Recommended Operating Conditions</u></b>						
Parameter	Symbol	Conditions	Min	Typ	Max	Units
Positive Supply Voltage	V <sub>CC</sub>		+5		+15	V

<b><u>Electrical Characteristics<sup>2</sup></u></b>						
Parameter	Symbol	Conditions	Min	Typ	Max	Units
Supply Current	I <sub>CC</sub>	No signal; V <sub>CC</sub> =+7 VDC	—	7.0	9.0	mA
Reference Voltage	V <sub>REF</sub>		1.8	1.95	2.1	V
<b>Encode and Decode – Companding Noise Reduction ( V<sub>CC</sub> = +7V encoder, +15V decoder)</b>						
Encode Level Match	LMe	Encode mode; f = 1kHz	-25.3	-23.0	-20.7	dBV
Encode Gain Accuracy	GAe1	Encode mode, f = 1kHz Vin = LMe + 10dB	+3.5	+5	+6.5	dB
	GAe2	Vin = LMe - 40dB	-23	-20	-17	dB
Decode Level Match	LMd	Decode mode; f = 1kHz	-18.3	-16.0	-13.7	dB
Decode Gain Accuracy	GAd1	Decode mode; f=1kHz Vin = LMd + 5dB	+8.5	+10	+11.5	dB
	GAd2	Vin = LMd - 20dB	-43	-40	-37	dB
Max Input Voltage	V <sub>ime</sub>	Encode mode; THD = 3%; f = 1kHz	3	5	—	dBV
Max Output Voltage	V <sub>omd</sub>	Decode mode; THD = 3%; f = 1kHz	10.7	13.7	—	dBV
Total Harmonic Distortion (with trim)	THDtrim	End-to-end; Vin = LMe; f = 1kHz	—	0.025	—	%
Total Harmonic Distortion (no trim)	THDnotrim	End-to-end; Vin = LMd; f = 1kHz	—	0.15	0.7	%
Output Noise	V <sub>nod</sub>	End-to-end ; Vin = short; A-weighted	—	7	—	μVrms

1. All specifications are subject to change without notice.
2. Unless otherwise noted, T<sub>A</sub>=25°C, test circuit as shown in Fig 2.

<b>Electrical Characteristics (con't)</b>						
Parameter	Symbol	Conditions	Min	Typ	Max	Units
<b>Op amp OA1</b>						
Offset Voltage	$V_{IO}$	$R_L = 2k\Omega$	—	$\pm 0.5$	$\pm 6$	mV
Equivalent Input Noise	$V_{nOA1}$	A-weighted	—	6.5	10	$nV/\sqrt{Hz}$
Total Harmonic Distortion	$THD_{OA1}$	1kHz, $A_V=1$ ; $R_L = 10k\Omega$	—	0.0007	0.003	%
Open Loop Gain	$A_{VO-OA1}$	$R_L = 10k\Omega$	—	115	—	
Gain Bandwidth Product	$GBW_{OA1}$	at 50kHz	—	5	—	
Slew Rate	$SR_{OA1}$		—	2	—	
<b>Op amp OA2</b>						
Offset Voltage	$V_{IO}$	$R_L = 2k\Omega$	—	$\pm 0.5$	$\pm 6$	mV
Equivalent Input Noise	$V_{nOA1}$	A-weighted	—	7.5	12	$nV/\sqrt{Hz}$
Total Harmonic Distortion	$THD_{OA1}$	1kHz, $A_V=1$ ; $R_L = 10k\Omega$	—	0.0007	0.003	%
Open Loop Gain	$A_{VO-OA1}$	$R_L = 10k\Omega$	—	110	—	
Gain Bandwidth Product	$GBW_{OA1}$	at 50kHz	—	5	—	
Slew Rate	$SR_{OA1}$		—	2	—	

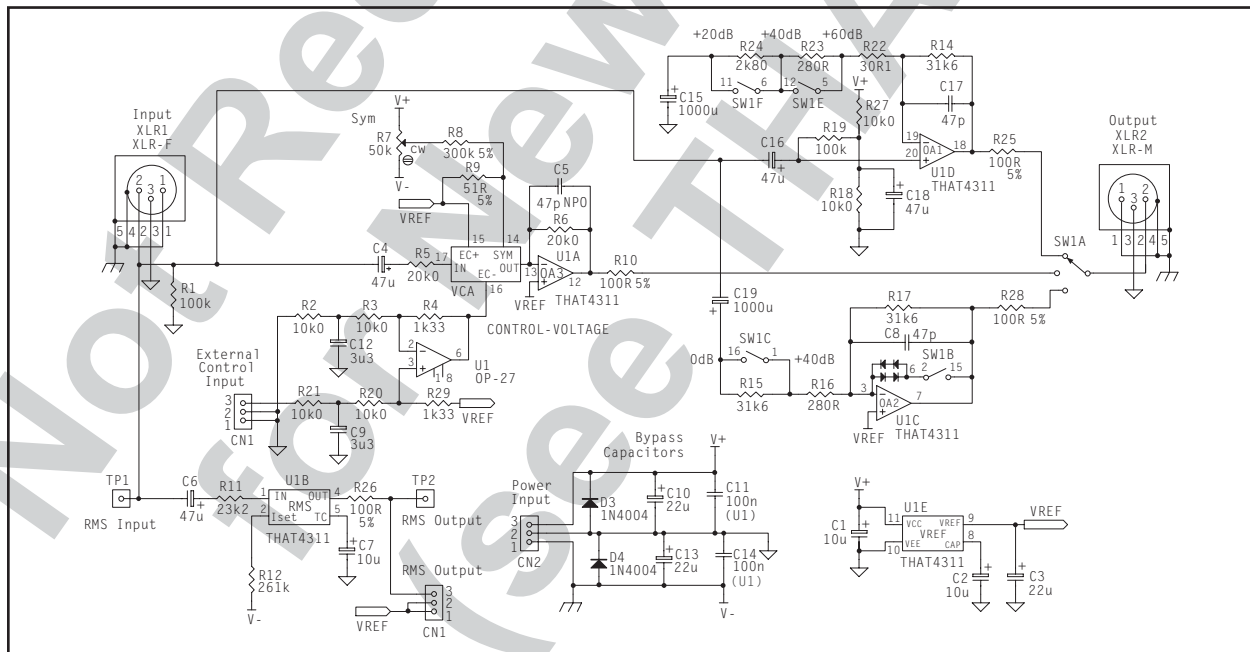

Fig 2. THAT 4311 test circuit

### Representative Data (Stand-alone)

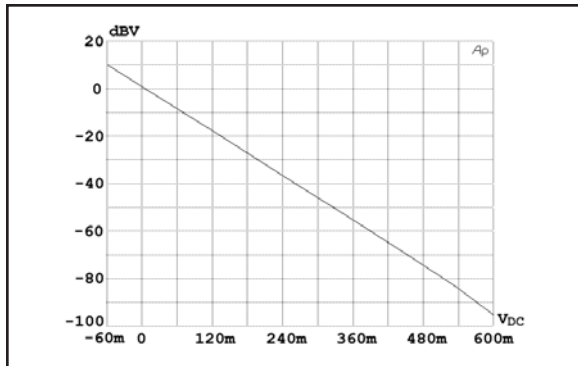

Fig 3. VCA Gain vs. Control Voltage (Ec-) at 25°C

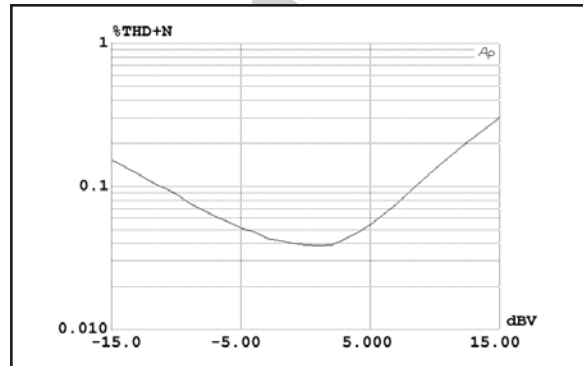

Fig 4. VCA 1kHz THD+Noise vs. Input, -15 dB Gain

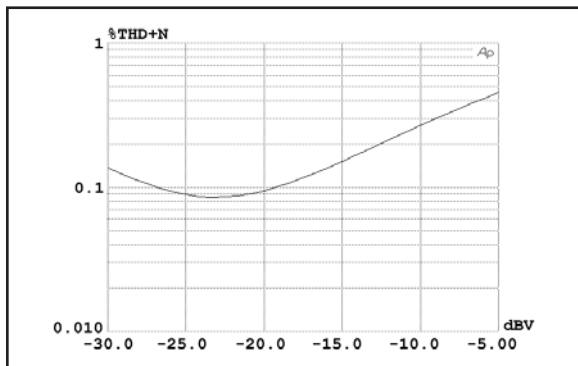

Fig 5. VCA 1kHz THD+Noise vs. Input, +15 dB Gain

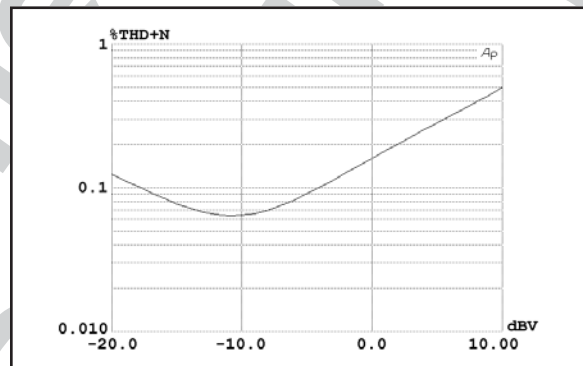

Fig 6. VCA 1kHz THD+Noise vs. Input, 0 dB Gain

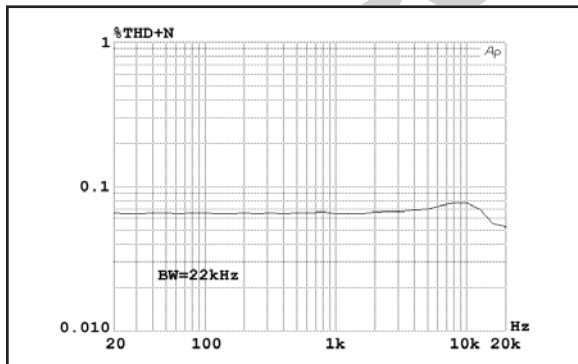

Fig 7. VCA THD vs. Frequency, 0 dB gain, 1 Vrms Input

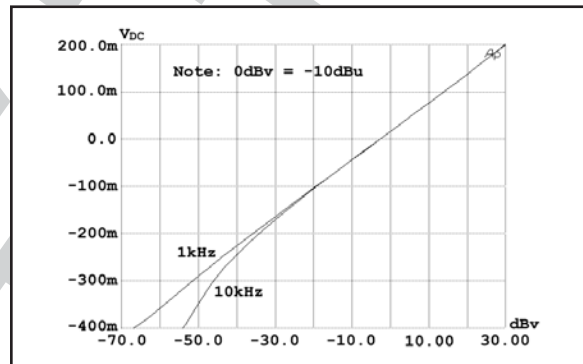

Fig 8. RMS Output vs. Input Level, 1 kHz & 10 kHz

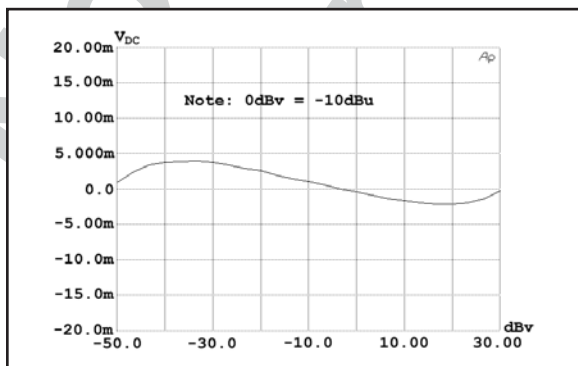

Fig 9. Departure from Ideal Detector Law vs. Level

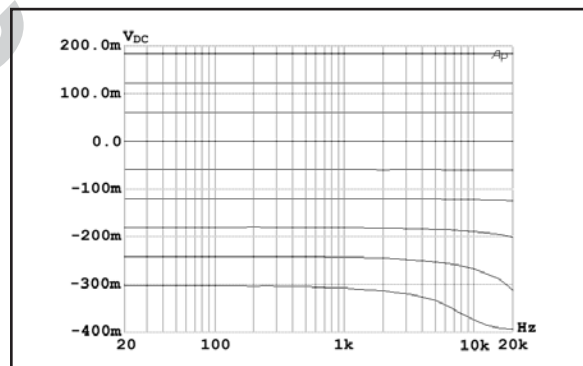

Fig 10. Detector Output vs. Frequency at Various Levels

### Representative Data (Companding Noise Reduction)

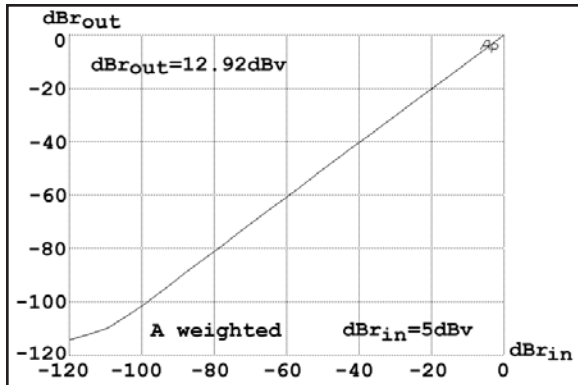

Fig 11. End-to-End Transfer Function, 1kHz

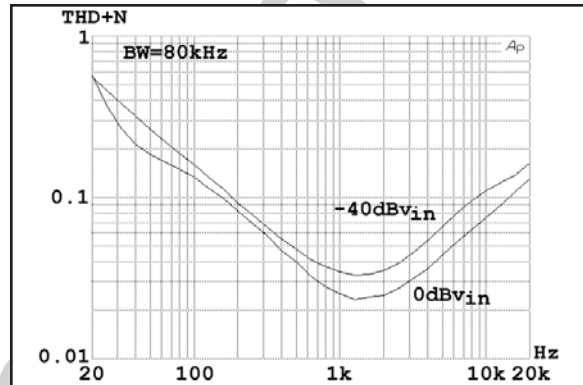

Fig 12. End-to-End THD+N

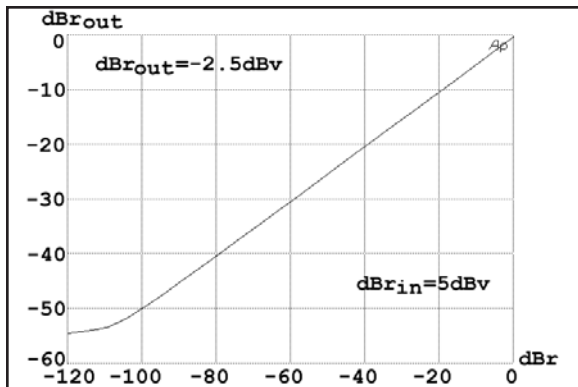

Fig 13. Encoder Transfer Function, 1kHz

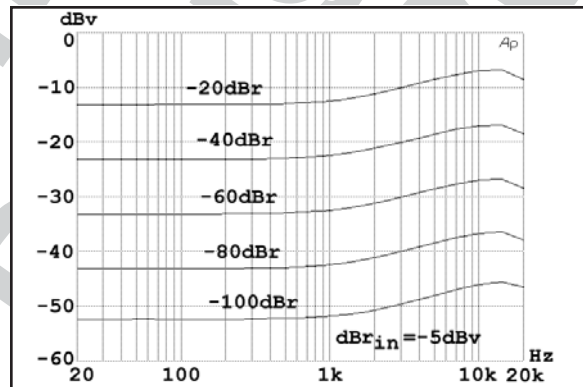

Fig 14. Encoder Frequency Response 20-20kHz

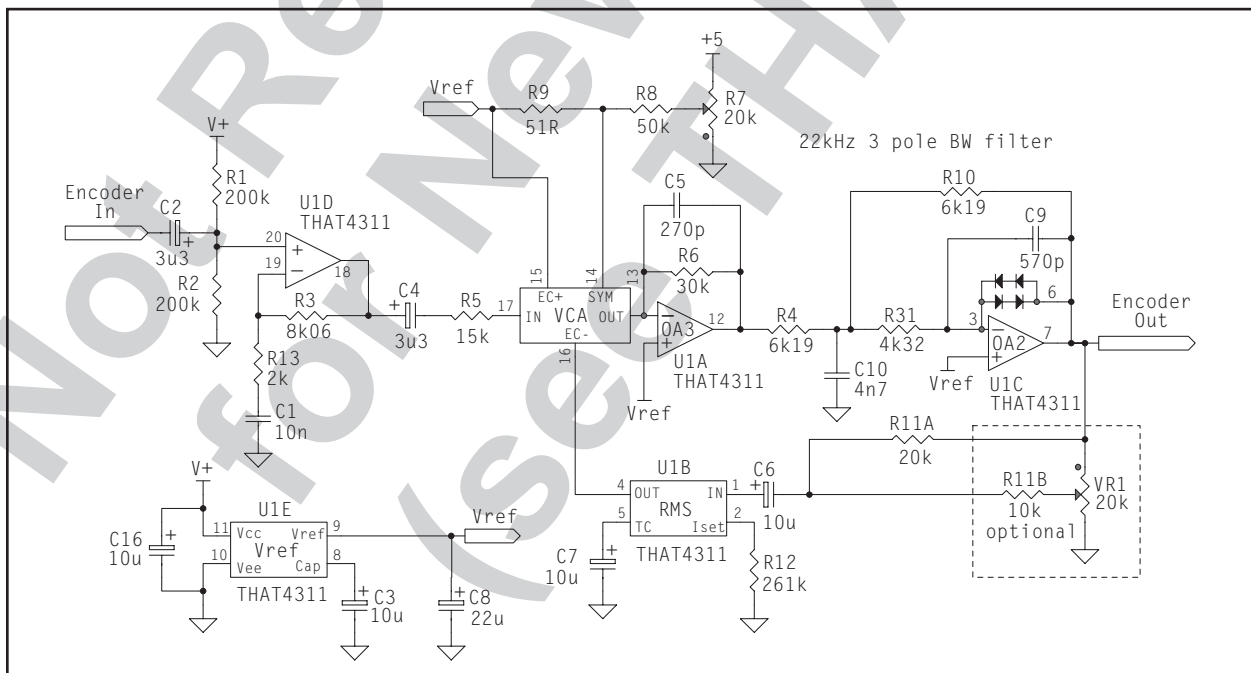

Fig 15. THAT 4311 Noise Reduction Encoder Schematic

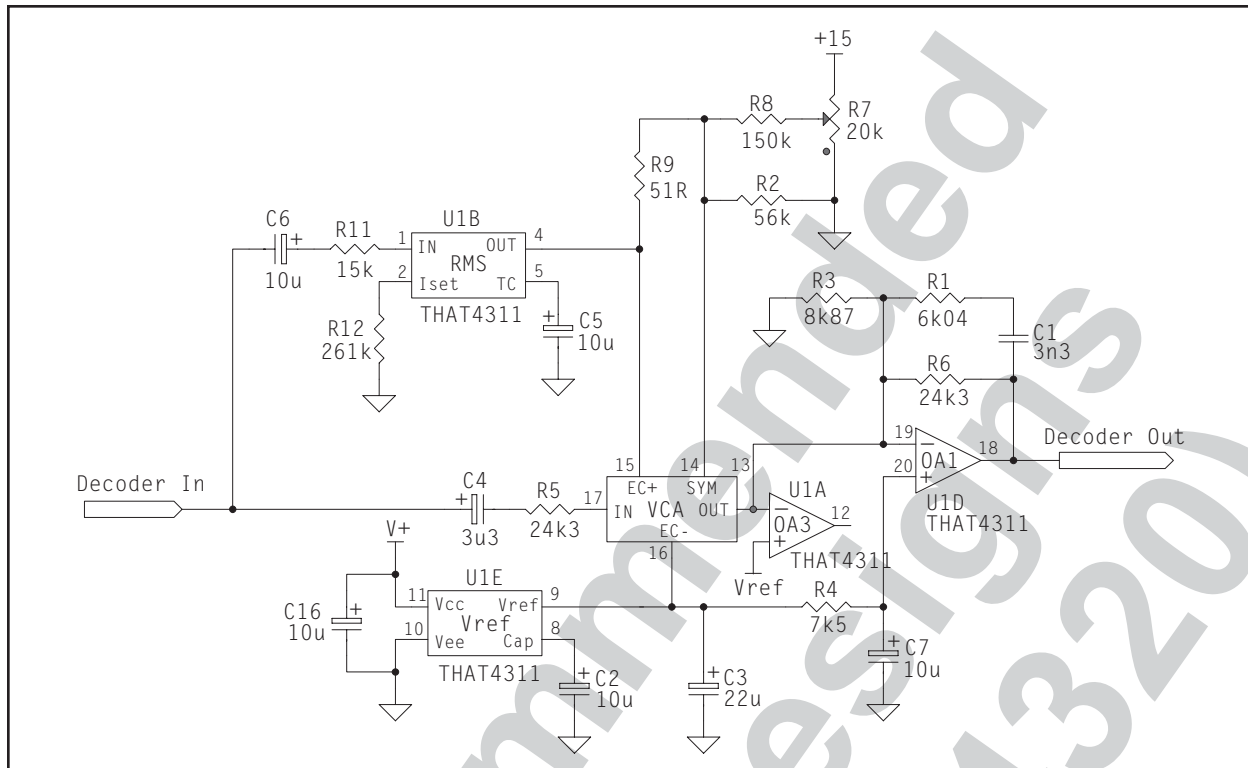

Fig 16. THAT 4311 Noise Reduction Decoder Schematic

### Theory of Operation

The THAT 4311 Analog Engine® Dynamics Processor combines THAT's proven Voltage-Controlled Amplifier (VCA) and RMS-Level Detector designs with three opamps to produce a multipurpose dynamics processor useful in a variety of applications. For details of the theory of operation of the VCA and RMS Detector building blocks, the interested reader is referred to THAT Corporation's data sheets on the 218x Series VCAs and the 2252 RMS-Level Detector. Theory of the interconnection of exponentially-controlled VCAs and log-responding level detectors is covered in THAT Corporation's application note AN101, [The Mathematics of Log-Based Dynamic Processors](#).

#### The VCA - in Brief

The THAT 4311 VCA is based on THAT Corporation's highly successful complementary log/anti-log gain cell topology, as used in THAT's 218x and 215x-Series IC VCAs. The THAT 4311 is integrated using a fully complementary, BiFET process. The combination of FETs with high-quality, complementary bipolar transistors (NPNs and PNPs) allows additional flexibility in the design of the VCA over previous efforts.

Input signals are currents to the VCA IN pin. This pin is a virtual ground biased at VREF, so in normal operation an input voltage is converted to input current via an appropriately sized resistor (R5 in Fig 2, Page 3). Because the current associated with DC offsets relative to VREF present at the input pin and any DC offset in preceding stages will be modulated by gain changes (thereby becoming audible as thumps), the input pin is normally AC-coupled (C4 in Fig 2).

The VCA output signal is also a current, inverted with respect to the input current. In normal operation, the output current is converted to a voltage via inverter OA3, where the ratio of the conversion is determined by the feedback resistor (R6, Fig 2) connected between OA3's output and its inverting input. The signal path through the VCA and OA3 is non-inverting.

The gain of the VCA is controlled by the voltage applied between EC- and the combination of EC+ and SYM. Gain (in decibels) is proportional to EC-, provided that EC+ and SYM are at VREF. The constant of proportionality is -6.1mV/dB (for 5V supplies) for the voltage at EC-, and 6.1mV/dB for the voltage at EC+, and SYM

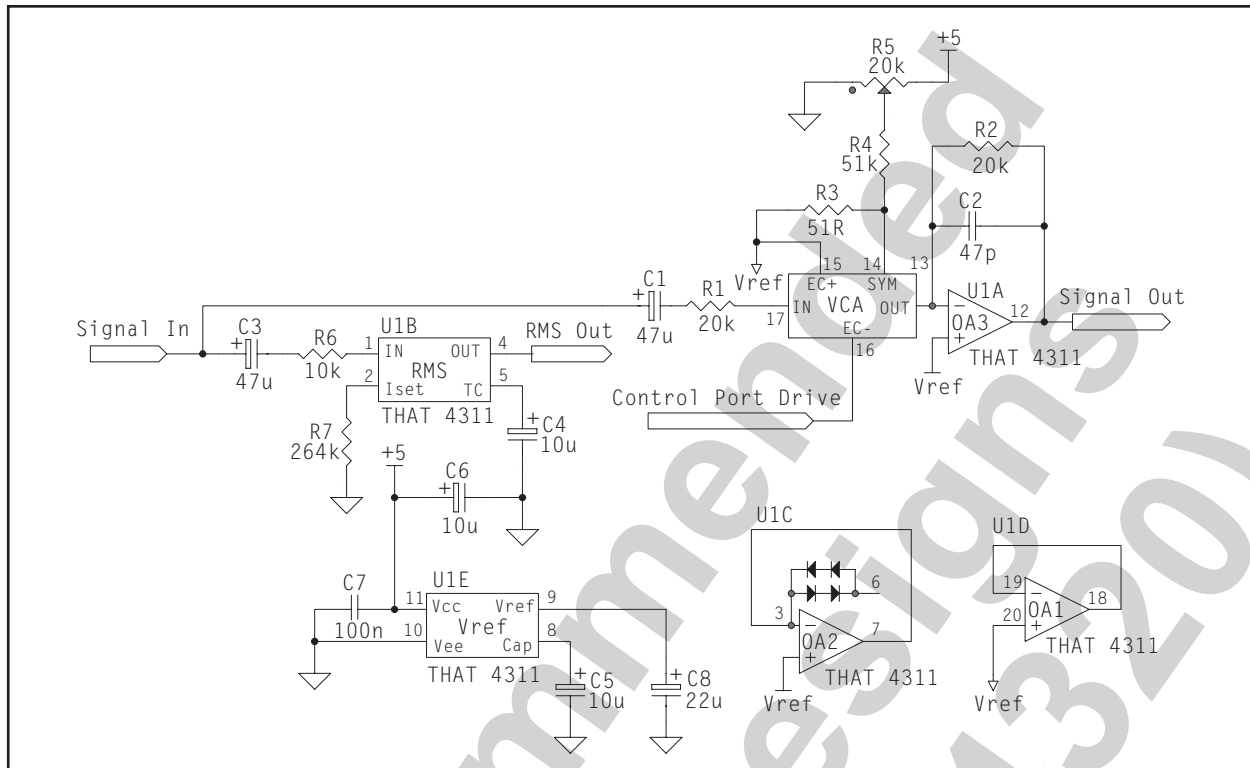

Fig 17. Circuit showing gain control at EC-.

As mentioned, for proper operation, the same voltage must be applied to EC+ and SYM, except for a small ( $\pm 2.5$  mV) DC bias applied *between* these pins. This bias voltage adjusts for internal mismatches in the VCA gain cell which would otherwise cause small differences between the gain of positive and negative half-cycles of the signal. The voltage is usually applied via an external trim potentiometer (R7 in Fig 2), which is adjusted for minimum signal distortion at unity (zero dB) gain.

The VCA may be controlled via EC-, as shown in Fig 17, or via the combination of EC+ and SYM. This connection is illustrated in Fig 18. Note that this latter figure shows only that portion of the circuitry needed to drive the positive VCA control port; circuitry associated with OA1, OA2 and the RMS detector has been omitted.

While the 4311's VCA circuitry is very similar to that of the THAT 2180 Series VCAs, there are several important differences, as follows:

1. Supply current for the VCA is fixed internally. Approximately  $500\mu\text{A}$  is available for the sum of input and output signal currents.
2. The signal current output of the VCA is internally connected to the inverting input of an on-chip

opamp. In order to provide external feedback around this opamp, this node is brought out to a pin.

3. The input stage of the 4311 VCA uses integrated P-channel FETs rather than a bias-current corrected bipolar differential amplifier. Input bias currents have therefore been reduced.

## The RMS Detector - in Brief

The THAT 4311's detector computes RMS level by rectifying input current signals, converting the rectified current to a logarithmic voltage, and applying that voltage to a log-domain filter. The output signal is a DC voltage proportional to the decibel-level of the RMS value of the input signal current. Some AC component (at twice the input frequency) remains superimposed on the DC output. The AC signal is attenuated by a log-domain filter, which constitutes a single-pole roll-off with cutoff determined by an external capacitor and a programmable DC current.

As in the VCA, input signals are currents to the RMS IN pin. This input is a virtual ground biased at VREF, so a resistor (R11 in Fig 2) is normally used to convert input voltages to the desired current. The level detector is capable of accurately resolving signals well below 10mV (with a  $10\text{k}\Omega$  input resistor). However, if the detector is to accurately track such low-level signals, AC coupling is normally required.

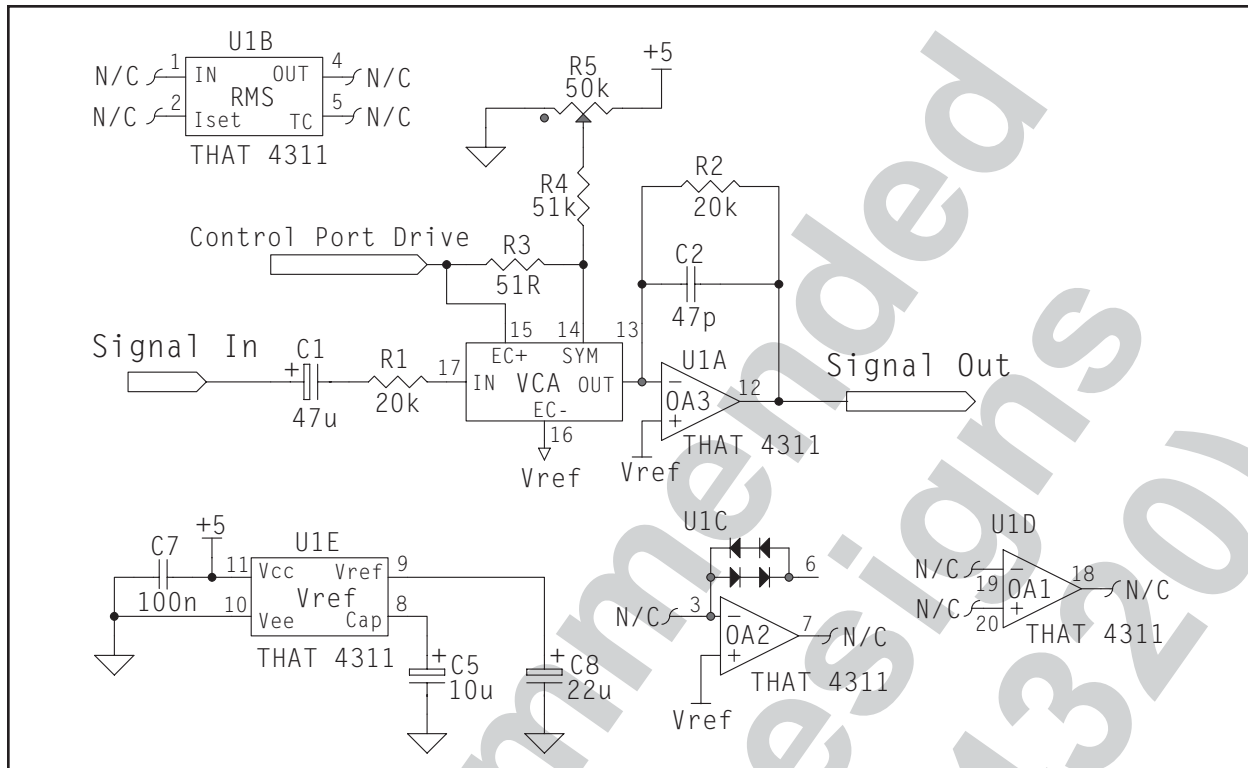
Fig 18. Circuit showing gain control at  $EC+$ 

The log-domain filter cutoff frequency is usually placed well below the frequency range of interest. For an audio-band detector, a typical value would be 5Hz, or a 32ms time constant ( $\tau$ ). The filter's time constant is determined by an external capacitor attached to the CT pin, and an internal current source ( $I_{TIME}$ ) connected to CT. The current source is programmed via the IT pin: current in IT is mirrored to  $I_{TIME}$  with a gain of approximately one. The resulting time constant  $\tau$  is approximately equal to  $(0.026 \times CT) / I_T$ . Note that, as a result of the mathematics of rms detection, the attack and release time constants are fixed in their relationship to each other.

The DC output of the detector is scaled with the same constant of proportionality as the VCA gain control: 6.1mV/dB. The detector's zero dB reference ( $I_{in0}$ , the input current which causes zero volts output), is determined by IT as follows:  $I_{in0} = IT$ . The detector output stage is capable of sinking or sourcing 100 $\mu$ A.

Differences between the 4311's RMS-Level Detector circuitry and that of the THAT 2252 RMS Detector are as follows:

1. The rectifier in the 4311 RMS Detector is internally balanced by design, and cannot be balanced via an external control. The 4311 will typically balance positive and negative halves of the input signal within

$\pm 1.5\%$ , but in extreme cases the mismatch may reach +20%. However, a 20% mismatch will not significantly increase ripple-induced distortion in dynamics processors over that caused by signal ripple alone.

2. The time constant of the 4311's RMS detector is determined by the combination of an external capacitor (connected to the CT pin) and an internal, programmable current source. The current source is equal to IT. Normally, a resistor is not connected directly to the CT pin on the 4311.

3. The zero dB reference point, or level match, is not adjustable via an external current source. However, as in the 2252, the level match is affected by the timing current, which, in this case, is drawn from the IT pin and mirrored internally to CT.

4. The input stage of the 4311 RMS detector uses integrated P-channel FETs rather than a bias-current corrected bipolar differential amplifier. Input bias currents are therefore negligible, improving performance at low signal levels.

## The Opamps - in Brief

The three opamps in the 4311 are intended for general purpose applications. All are 5MHz opamps with slew rates of approximately 2V/ $\mu$ s. All use bipolar PNP input stages. However, the design of each is optimized for its expected use. Therefore, to get the

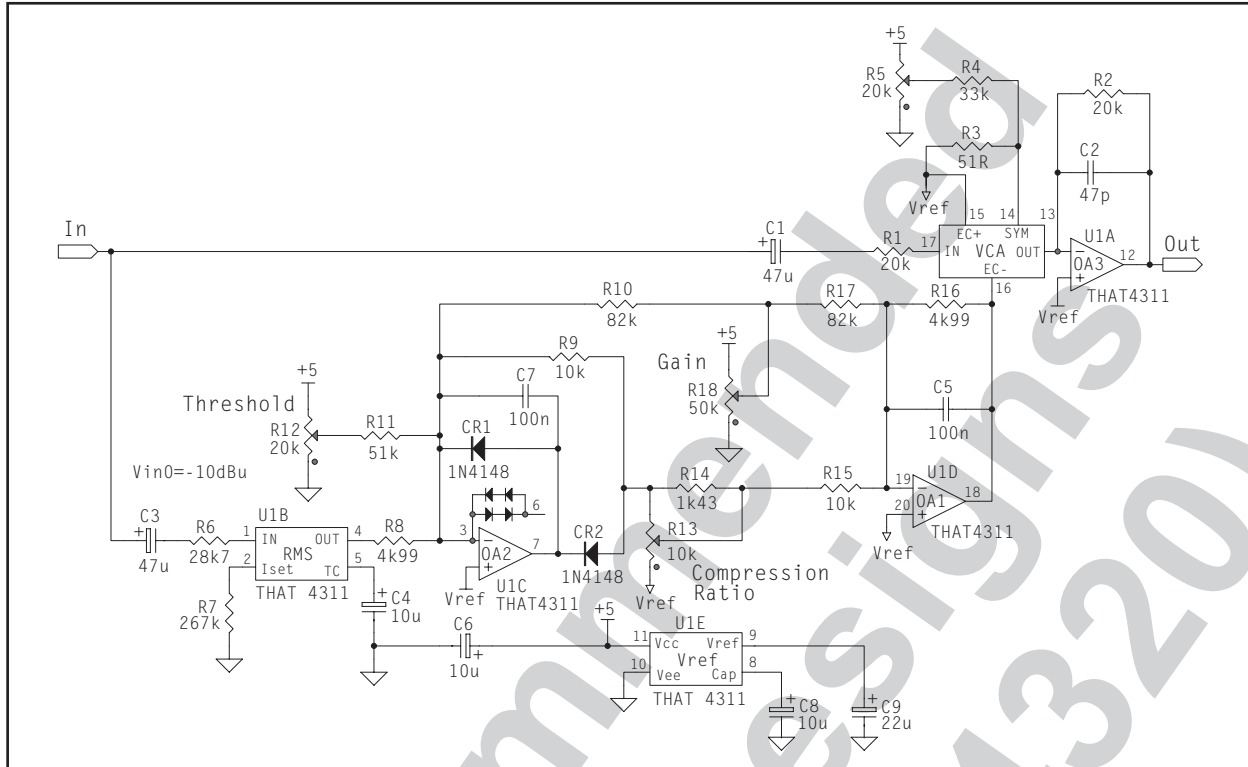

Fig 19. Simple compressor / limiter using the THAT 4311

most out of the 4311, it is useful to know the major differences among these opamps.

OA3, being internally connected to the output of the VCA, is intended for current-to-voltage conversion. Its input noise performance, at  $7.5nV/\sqrt{Hz}$ , complements that of the VCA, adding negligible noise at unity gain. Its output section is capable of driving 1mA into a 2k $\Omega$  load.

OA1 is the quietest opamp of the three, and with its typical input referred noise of  $6.5nV/\sqrt{Hz}$ , is the opamp of choice for input stages. Its output section is nominally capable of driving 3mA into a 5k $\Omega$  load.

OA2 is best suited for control voltage processing, though it does have anti-paralleled diodes that can

be used to fashion it into a clipper. (However in most applications where a clipper is needed, it's preferable to place it around OA3). OA2's input noise is comparable to OA3 and its output drive is comparably to OA1.

## The Reference Voltage - In Brief

THAT Corporation's log/anti-log VCAs and RMS detectors require a reference voltage between the positive and negative power supplies, and to supply this, the THAT 4311 provides an on-chip, 2V reference about which the VCA, the RMS detector, and OA2 are biased. This reference is a buffered band-gap reference that is amplified to 2V. Pins are provided for filter capacitors at both the input and the output of the buffer, which are labeled CAP and VREF respectively.

## Application Information

As noted previously, the THAT 4311 was originally designed for noise reduction systems, hence the emphasis on those parameters in the specifications. Its low power consumption, integration, and similarity to the THAT 4301, however, extend its utility to a variety of other products and applications. The circuit of Fig 19, shows a typical application for the THAT 4311. This simple compressor/limiter design features adjustable hard-knee threshold, compression ratio, and static gain. The applications discussion in this data sheet will center on this circuit for the purpose of illustrating important design issues.

tion ratio, and static gain. The applications discussion in this data sheet will center on this circuit for the purpose of illustrating important design issues.

## Signal Path

As mentioned in the section on theory, the VCA input pin is a virtual ground with negative feedback provided internally. An input resistor (R1, 20k $\Omega$ ) is required to convert the AC input voltage to a current

within the linear range of the THAT 4311. (Peak VCA input currents should be kept under 250  $\mu\text{A}$  for best distortion performance.) The coupling capacitor (C1, 47  $\mu\text{F}$ ) is strongly recommended to block DC current from preceding stages (and from offset voltage at the input of the VCA). Any DC current into the VCA will be modulated by varying gain in the VCA, showing up in the output as “thumps”. Note that C1, in conjunction with R1, will set the low frequency limit of the circuit.

The VCA output is connected to OA3, configured as an inverting current-to-voltage converter. OA3's feedback components (R2, 20 k $\Omega$ , and C2, 47 pF) determine the constant of current-to-voltage conversion. The simplest way to deal with this is to recognize that when the VCA is set for unity (zero dB) gain, the input to output voltage gain is simply R2/R1, much like the case of a single inverting stage. If, for some reason, more than zero dB gain is required when the VCA is set to unity, then the resistors may be skewed to provide it. Note that the feedback capacitor (C2) is required for stability. The VCA output has approximately 45pF of capacitance to ground, which must be neutralized via the 47pF feedback capacitor across R2.

The VCA gain is controlled via the EC- terminal, whereby gain in dB will be proportional to the negative of the voltage at EC-. In this application the EC+ terminal is tied to VREF, though it could be the driven port, or the control ports could be driven differentially. The SYM terminal is returned nearly to the EC+ terminal (which is in this case VREF) via a small resistor (R3, 51 $\Omega$ ). The VCA SYM trim (R5, 20k $\Omega$ ) allows a small voltage to be applied to the SYM terminal via R4 (33k $\Omega$ ). This voltage adjusts for small mismatches within the VCA gain cell, thereby reducing even-order distortion products. To adjust the trim, apply to the input a middle-level, middle-frequency signal (1kHz at 200mV<sub>rms</sub> is a good choice with this circuit) and observe THD at the signal output. Adjust the trim for minimum THD.

## RMS-Level Detector

The RMS detector's input is similar to that of the VCA. An input resistor (R6, 28.7k $\Omega$ ) converts the AC input voltage to a current within the linear range of the THAT 4311. The coupling capacitor (C3, 47 $\mu\text{F}$ ) is recommended to block the current from preceding stages (and from offset voltage at the input of the detector). Any DC current into the detector will limit the low-level resolution of the detector, and will upset the rectifier balance at low levels. Note that, as with

the VCA input circuitry, C3 in conjunction with R6 will set the lower frequency limit of the detector.

The time response of the RMS detector is determined by the capacitor attached to CT (C4, 10  $\mu\text{F}$ ) and the size of the current in pin IT (determined by R7, 267 k $\Omega$  and VREF, 2V). Since the voltage at IT is approximately 2V, the circuit of Figure 19 produces 7.5  $\mu\text{A}$  in IT. The current in IT is mirrored to the CT pin, where it is available to discharge the timing capacitor (C4). The combination produces a log filter with time constant equal to approximately 0.026 CT/IT (~35 ms in the circuit shown).

The waveform at CT will follow the logged (decibel) value of the input signal envelope, plus a DC offset of about  $2V_{BE}$  plus VREF or about 3.3V. The capacitor used should be a low-leakage, electrolytic type in order not to add significantly to the timing current.

The output stage of the RMS detector serves to buffer the voltage at CT and removes the  $1.3 V_{DC}$  ( $2 V_{BE}$ ) offset, resulting in an output centered around VREF for input signals of about 245 mV<sub>rms</sub>, or -10 dBu. The output voltage increases 6.1 mV for every 1 dB increase in input signal level. This relationship holds over more than a 60 dB range in input currents.

## Control Path

The primary function of an audio compressor is to reduce a signal's dynamic range. A 2:1 compressor reduces a 100 dB dynamic range to 50 dB. A limiter, or infinite compressor, is a special case of compressor where the dynamic range is reduced to the point where the rms level of the signal is constant. This reduction in dynamic range is accomplished by a) raising the gain when the signal is below some particular level -- often referred to as the 'zero dB reference level' -- and b) reducing the gain when the signal is above that level. In addition, these devices often have a threshold, below which the signal is passed unprocessed and above which compression takes place. This feature keeps the noise floor from rising to noticeable levels in the absence of signal.

We previously established that the zero dB reference level of the detector is -10 dBu (zero dB reference level = 7.5  $\mu\text{A}$ , R6 = 28.7 kilohms). Neglecting the effect of the threshold control (R11 and R12), when the output is below this level the output of OA2 is driven high, forward biasing CR1 and reverse biasing CR2. Since CR2 is not conducting, no signal is passed to the VCA's control port by OA1. When the signal level exceeds -10 dBu, the output of the RMS detector goes positive, and CR2 begins to conduct. In

this case, OA2's feedback is provided through R9, and the sensitivity at this point is 12.2 mV/dB, since the output of the RMS detector is multiplied by  $-R9/R8$ , or a gain of -2.

A threshold control is provided to vary the threshold above or below -10 dBu. The output sensitivity of the RMS detector is 6.1 mV/dB. This is converted to a current by R8, and the sensitivity at the summing node of OA2 is

$$\frac{6.1 \frac{mV}{dB}}{4.99 k\Omega} = 1.2 \mu A$$

The wiper of R12 can swing between -2V and +3V relative to the summing node of OA2 which is at VREF. If we want the threshold to swing as high as +30 dB, then the value required for R11 can be calculated as

$$R11 = \frac{2V}{1.2 \frac{\mu A}{dB} \times 30 dB} \approx 51 k\Omega$$

when rounded to the nearest 5% resistor value. Using this value and knowing that the pot's swing in the other direction is 3V, we can calculate the threshold swing in the negative direction to be

$$\frac{3V}{51 k\Omega} \approx -49 \frac{dB}{dB}$$

Since the zero dB reference level of the detector is -10 dBu, the threshold can be adjusted from 20 dBu to -59 dBu.

The output of the threshold detector represents the signal level above the determined threshold, at a constant of about 13mV/dB (from  $[R9/R8]$  6.1mV/dB). This signal is passed on to the COMPRESSION control (R13), which variably attenuates the signal passed on to OA1. Note that the gain of OA1, from the wiper of the COMPRESSION control to OA1's output is  $R16/R15$  (0.5), precisely the inverse of the gain of OA2. Therefore, the COMPRESSION control lets the user vary the above threshold gain between the RMS detector output and the output of OA1, from zero to a maximum of unity.

The gain control constant of the VCA (6.1mV/dB) is exactly equal to the output scaling constant of the RMS detector. Therefore, at maximum COMPRESSION, above threshold, every dB increase in input signal level causes a 6.1mV increase in the output of OA1, which in turn causes a 1dB decrease in the VCA gain. With this setting, the output will not increase despite large increases in input level above threshold. This is infinite compression. For intermediate settings of COMPRESSION, a 1dB increase in input signal level will cause less than a 1dB decrease in gain, thereby varying the compression ratio.

The resistor R14 is included to alter the taper of the COMPRESSION pot to better suit common usage.

If a linear taper pot is used for R13, the compression ratio will be 1:2 at the middle of the rotation. However, 1:2 compression in an above-threshold compressor is not very strong processing, so 1:4 is often preferred at the midpoint. R14 warps the taper of R13 so that 1:4 compression occurs at approximately the midpoint of R13's rotation,

The GAIN control (R18) is used to provide static gain or attenuation in the signal path. This control adds between 120mV and -180mV of offset to the output of OA1, which is approximately a -20dB to +30dB change in gain of the VCA. The gain control signal is passed into OA1 via R17, but this signal is also passed back to the threshold amplifier (OA2) via R10. This arrangement results in the threshold being fixed relative to the output. In other words, as the gain is increased, the threshold is lowered to keep the threshold of compression or limiting at the same output level. This is particularly important in limiters, since it keeps the gain control from interacting with the threshold.

C5 is used to attenuate the noise of OA1, OA2, and the resistors R8 through R16 used in the control path. All these active and passive components produce noise which is passed on to the control port of the VCA, causing modulation of the signal. By itself, the THAT 4311 VCA produces very little noise modulation, and its performance can be significantly degraded by the use of noisy components in the control voltage path.

## Overall Result

The resulting compressor circuit provides hard-knee compression above threshold with three essential user adjustable controls. The threshold of compression may be varied over a range from about -58dBu to +20dBu. The compression ratio may be varied from 1:1 (no compression) to  $\infty$ :1. And, static gain may be added between -20 and +30dB. Audio performance is excellent, with THD running below 0.1% at middle frequencies even with 10 dB of compression, and an input dynamic range of over 105dB.

Perhaps most important, this example design only scratches the surface of the large body of applications circuits which may be constructed with the THAT 4311. The combination of an accurate, wide dynamic range, log-responding level detector with a high-quality, exponentially-responding VCA produces a versatile and powerful analog engine. These, along with its on-board opamps, allow a designer to construct, with a single IC and a handful of external components, gates, expanders, de-essers, noise reduction systems and the like.

## Package Information

The THAT 4311 is available in a 20-pin surface mount package. The package dimensions are shown in Fig 20 while the pinout is given in Table 1.

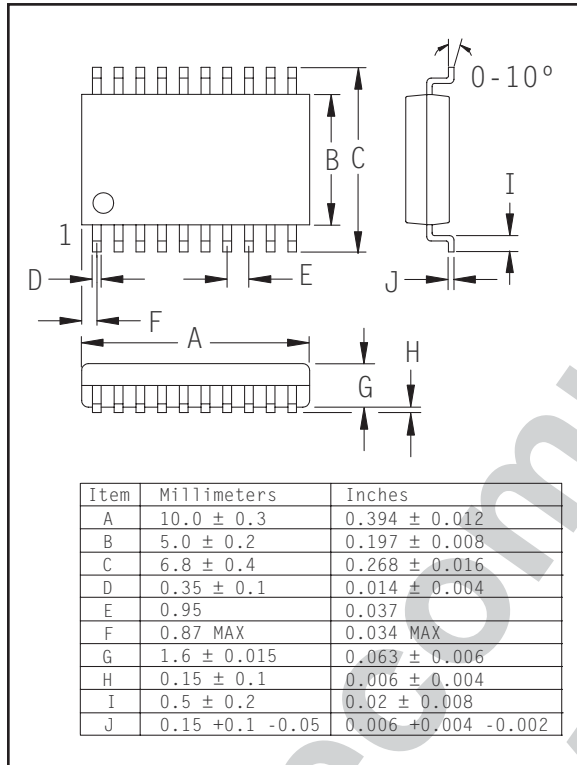

Figure 20. -S (DMP20 surface mount) package drawing