

FEATURES

- Pre-trimmed Blackmer® VCA & RMS-level detector
- Wide supply voltage range:
±4.5V ~ ±16V
- Low supply current:
3.5 mA typ. (±15V)
- Wide dynamic range:
117 dB (VCA)
60 dB (RMS-level detector)

APPLICATIONS

- Compressors & Limiters
- Gates & Expanders
- AGCs
- Line-operated dynamics processors
- De-Essers
- Duckers
- Mixers
- Level indicators
- Companding noise reduction systems

Description

The THAT4305 is a single-chip Analog Engine® optimized for low-cost applications. It incorporates a high-performance Blackmer® voltage-controlled amplifier (VCA) and log-responding RMS-level sensor. The VCA and RMS detector are pre-trimmed at wafer stage to deliver low distortion without further adjustment.

Available in a small (QSOP) surface-mount package, the 4305 is aimed at line-operated audio applications such as compressor/limiters, gates, and other dynamic processors. The part normally operates from a split supply voltage up to ±16Vdc, drawing only 3.5mA at ±15V. This IC also works at supply voltages as low as ±4.5V, making it useful in some battery-operated products as well.

The 4305 was developed specifically for use in low-cost dynamics processors, drawing from THAT's long history and experience with such designs. Both VCA control ports and the detector input and output are available for the designer to connect as s/he sees fit. As a result, the part is extremely flexible and can be configured for a wide range of applications including single- and multi-band compressors, digital overload protectors, voltage-controlled faders, level indicators, etc.

What really sets the 4305 apart from other manufacturers' offerings is the transparent sound of its Blackmer VCA, coupled with its accurate true-RMS level detector. This makes the IC useful in a wide range of analog audio products.

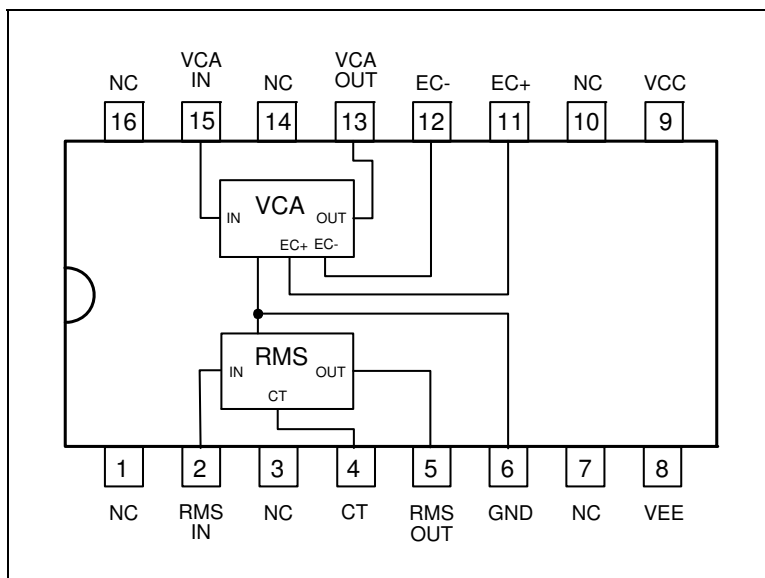

Figure 1. THAT 4305 equivalent block diagram

Pin Name	Pin Number
No Connection	1
RMS IN	2
No Connection	3
C _{TIME}	4
RMS OUT	5
GND	6
No Connection	7
Vee	8
Vcc	9
No Connection	10
EC+	11
EC-	12
VCA OUT	13
No Connection	14
VCA IN	15
No Connection	16

Table 2. Pin assignments

Package	Order Number
16 pin QSOP	4305Q16-U

Table 1. Ordering information

SPECIFICATIONS

Absolute Maximum Ratings¹

Operating Temperature Range (T_{OP})	-40 to +85 °C	Supply Voltages (V_{CC} , V_{EE})	±18V
Junction Temperature (T_J)	-40 to +125 °C	VCA Control Voltage	±0.6 V
Power Dissipation (P_D) at $T_A=85$ °C	400mW	Storage Temperature Range (T_{ST})	-40 to +125 °C

Electrical Characteristics²

Parameter	Symbol	Conditions	Min	Typ	Max	Units
Power Supply						
Positive Supply Voltage	V_{CC}	Referenced to GND	+4.5	-	+16	V
Negative Supply Voltage	V_{EE}	Referenced to GND	-4.5	-	-16	V
Supply Current		No Signal				
	I_{CC}	$V_{CC}=+15V$, $V_{EE}=-15V$		3.5	5	mA
	I_{EE}	$V_{CC}=+15V$, $V_{EE}=-15V$		-3.5	-5	mA
	I_{CC}	$V_{CC}=+5V$, $V_{EE}=-5V$		2		mA
	I_{EE}	$V_{CC}=+5V$, $V_{EE}=-5V$		-2		mA
Voltage Controlled Amplifier (VCA)						
Max. I/O Signal Current	$i_{IN(VCA)} + i_{OUT(VCA)}$			±1.8		mA _{peak}
VCA Gain Range			-60		+60	dB
Gain at 0V Control	G_0	$E_{C+} = E_{C-} = 0V$	-1.0	0	+1.0	dB
Gain-Control Constant	$E_{C+}/\text{Gain (dB)}$	-60 dB < gain < +60 dB	-	6.2	-	mV/dB
Gain-Control Tempco	$\Delta E_C/\Delta T_{CHIP}$	Ref $T_{CHIP}=27^\circ C$	-	+0.33	-	%/°C
Output Offset Voltage Change ³ $\Delta V_{OFF(OUT)}$		$R_{OUT} = 20\text{ k}\Omega$ 0 dB gain +15 dB gain +30 dB gain	-	1 3 10	15 30 50	mV
Output Noise	$e_{N(OUT)}$	0 dB gain 22Hz~22kHz, $R_{IN}=R_{OUT}=20\text{ k}\Omega$	-	-97.5	-95	dBV
Total Harmonic Distortion	THD	$V_{IN} = -5\text{dBV}$, 1kHz, $E_{C+} = E_{C-} = 0V$		0.07	0.15	%
RMS Level Detector						
Output Voltage at Reference i_{IN}	$e_{O(0)}$	$i_{IN} = 7.5\ \mu A$ RMS	-9	0	+9	mV
Output Error at Input Extremes	$e_{O(RMS)error}$	$i_{IN} = 200\text{ nA}$ RMS $i_{IN} = 200\ \mu A$ RMS		±1 ±1	±3 ±3	dB
Scale Factor Match to VCA		-20 dB < VCA gain < +20 dB $1\ \mu A < i_{IN(RMS)} < 100\ \mu A$.95	1	1.05	-

1. If the devices are subjected to stress above the Absolute Maximum Ratings, permanent damage may result. Sustained operation at or near the Absolute Maximum Ratings conditions is not recommended. In particular, like all semiconductor devices, device reliability declines as operating temperature increases.

2. Unless otherwise noted, $T_A=25^\circ C$, $V_{CC}=+15V$, $V_{EE}=-15V$.

3. Reference is to output offset with -60 dB VCA gain.

Electrical Characteristics (con't)²						
Parameter	Symbol	Conditions	Min	Typ	Max	Units
Rectifier Balance		$\pm 7.5\mu\text{A DC}_{\text{IN}}$		± 1	± 3	dB
Timing Current	I_T		-	7.5	-	μA
Filtering Time Constant	τ			$3467 \times C_{\text{TIME}}$		s
Output Tempco	$\Delta E_O / \Delta T_{\text{CHIP}}$	Ref $T_{\text{CHIP}} = 27^\circ\text{C}$	-	+0.33	-	%/ $^\circ\text{C}$
Load Resistance	R_L	$-250\text{mV} < V_{\text{OUTRMS}} < +250\text{mV}$	2			k Ω
Capacitive Load	C_L				150	pF

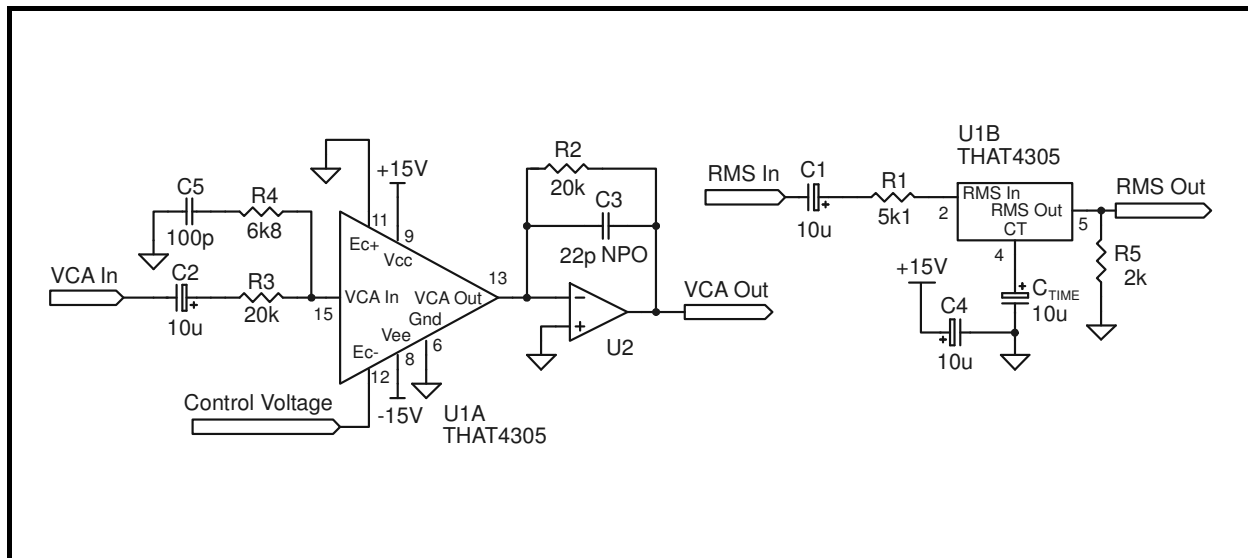

Figure 2. Simplified application circuit

Theory of Operation

The THAT 4305 Dynamics Processor combines THAT Corporation's proven exponentially controlled Blackmer® Voltage-Controlled Amplifier (VCA) and log-responding RMS-Level Detector building blocks in a small package optimized for low cost designs. The part is fabricated using a proprietary, fully complementary, dielectric-isolation process. This process produces very high-quality bipolar transistors (both NPNs and PNPs) with unusually low collector- substrate capacitances. The 4305 takes advantage of these devices to deliver wide bandwidth and excellent audio performance while consuming very low current and operating over a wide range of power supply voltages.

For details of the theory of operation of the VCA and RMS Detector, we refer the interested reader to THAT Corporation's data sheets on the 2180-Series

VCAs and the 2252 RMS Level Detector. Theory of the interconnection of exponentially controlled VCAs and log-responding level detectors is covered in THAT Corporation's application note AN101A, *The Mathematics of Log-Based Dynamic Processors*.

The VCA - in Brief

The VCA in the 4305 is based on THAT Corporation's highly successful complementary log-antilog gain cell topology (the Blackmer® VCA) as used in THAT 2180-Series IC VCAs. VCA symmetry is trimmed during wafer probe for minimum distortion. No external adjustment is allowed.

Input signals are currents in the VCA's VCA_{IN} pin (pin 15). This pin is a virtual ground with a small dc offset, so in normal operation an input voltage is

converted to input current via an appropriately sized resistor (R3 in Figure 2). Because the dc current associated with dc offsets present at the input pin plus any dc offset in the preceding stages will be modulated by gain changes (thereby becoming audible as thumps), the input pin is normally ac-coupled. This blocks such offset currents and reduces dc offset variation with gain.

The VCA output signal, VCA_{OUT} (pin 13), is also a current, inverted with respect to the input current. In normal operation, the output current is converted to a voltage via an external op-amp, where the current-to-voltage conversion ratio is determined by the feedback resistor connected between the op-amp's output and its inverting input (R2 in Figure 2). The resulting signal path through the VCA plus op-amp is noninverting.

The VCA gain is controlled by the voltage applied between E_{C+} (pin 11) and E_{C-} (pin 12). Note that any unused control port should be connected to ground (as E_{C+} is in Figure 2). The gain (in decibels) is proportional to $(E_{C+} - E_{C-})$. The constant of proportionality is 6.2 mV/dB for the voltage at E_{C+} (relative to E_{C-}). Note that neither E_{C+} or E_{C-} should be driven more than ± 0.6 V away from ground.

The VCA's noise performance varies with gain in a predictable way, but due to the way internal bias currents vary with gain, noise at the output is not strictly the product of a static input noise times the voltage gain commanded. At large attenuation, the noise floor is usually limited by the input noise of the output op-amp and its feedback resistor. At 0 dB gain, the noise floor of ~ -97.5 dBV is the result of the VCA's output noise current, converted to a voltage by the typical 20k I-V converter resistor (R2 in Figure 2). In the vicinity of 0 dB gain, the noise increases more slowly than the gain: approximately 5 dB noise increase for every 10 dB gain increase. Finally, as gain approaches 30 dB, output noise begins to increase directly with gain.

While the 4305's VCA circuitry is very similar to that of the THAT 2180 Series VCAs, there are several important differences, as follows.

1. Supply current for the 4305 VCA depends on the supply voltage. At ± 5 V, approximately 800 μ A is available for the sum of input and output signal currents. This increases to about 1.8 mA at ± 15 V.

(Compare this to ~ 1.8 mA for a 2180 Series VCA when biased as recommended.)

2. The SYM control port (similar to that on the 2180 VCA) is not brought out to an external pin; it is driven from an internally trimmed current generator.

3. The control-voltage constant is approximately 6.2 mV/dB, due primarily to the higher internal operating temperature of the 4305 compared to that of the 2180 Series.

The RMS Detector - in Brief

The 4305's detector computes RMS level by rectifying input current signals, converting the rectified current to a logarithmic voltage, and applying that voltage to a log-domain filter. The output signal is a dc voltage proportional to the decibel-level of the RMS value of the input signal current. Some ac component (at twice the input frequency plus higher-order even harmonics) remains superimposed on the dc output. The ac signal is attenuated by a log domain filter, which constitutes a single-pole rolloff with cutoff determined by an external capacitor (C4 in Figure 2).

The rectifier is balanced to within ± 3 dB, so a small amount of fundamental (and higher odd-order harmonics) ripple can be present at the detector output. By design, this ripple contributes less total ripple than the even-order products that are naturally and inevitably present at the output of a perfectly balanced detector.

As in the VCA, input signals are currents to the RMS_{IN} pin (pin 2). This input is a virtual ground, so a resistor (R1 in Figure 2) is normally used to convert input voltages to the desired current. The level detector is capable of accurately resolving signals well below 10 mV (with a 5 k Ω input resistor). However, if the detector is to accurately track such low-level signals, ac coupling (C1 in Figure 2) is required to prevent dc offsets from causing a dc current to flow in the detector's input, which would obscure low-level ac signal currents.

The log-domain filter cutoff frequency is usually placed well below the frequency range of interest. For an audio-band detector, a typical value would be 5 Hz, or a 32 ms time constant (τ). The filter's time constant is determined by an external timing

capacitor (C_{TIME}) attached to the C_T pin (pin 4), and an internal current source (I_T) connected to C_T . The current source is internally fixed at $7.5 \mu\text{A}$. The resulting time constant in seconds is approximately equal to 3467 times the value of the timing capacitor in Farads. Note that, as a result of the mathematics of RMS detection, the attack and release time constants are fixed in their relationship to each other.

The RMS detector is capable of driving large spikes of current into C_{TIME} , particularly when the audio signal input to the RMS detector increases suddenly. This current is drawn from V_{CC} (pin 9), fed through C_{TIME} at pin 4, and returns to the power supply through the ground end of C_{TIME} . If not handled properly through layout and bypassing, these currents can mix with the audio in the circuit's ground structure with unpredictable and undesirable results. As noted in the Applications section, local bypassing from the V_{CC} pin to the ground end of C_{TIME} is strongly recommended in order to keep these currents out of the ground structure of the circuit (see C4 in Figure 2.)

The dc output of the detector is scaled with the same constant of proportionality as the VCA gain control: 6.2 mV/dB. The detector's 0 dB reference (i_{in0} , the input current which causes the detector's output to equal 0V), is trimmed during wafer probe to equal approximately $7.5 \mu\text{A}$. The RMS detector output stage is capable of sinking or sourcing $125 \mu\text{A}$. It is also capable of driving up to 150 pF of capacitance.

Frequency response of the detector extends across the audio band for a wide range of input signal levels. Note, however, that it does fall off at high frequencies at low signal levels like THAT's other RMS detectors.

Differences between the 4305's RMS level detector circuitry and that of the THAT 2252 RMS detector include the following.

1. The rectifier in the 4305 RMS Detector is internally balanced by design, and cannot be balanced via an external control. The 4305 will typically balance positive and negative halves of the input signal within 10% but in extreme cases the mismatch may reach +40% or -30% ($\pm 3\text{dB}$). However, even such extreme-seeming mismatches will not significantly increase ripple-induced

distortion in dynamics processors over that caused by balanced signal ripple alone.

2. The time constant of the 4305's RMS detector is determined by the combination of an external capacitor C_{TIME} and an internal current source. The internal current source is set to about $7.5 \mu\text{A}$. A resistor is not normally connected directly to the C_T pin on the 4305.

3. The 0 dB reference point, or level match, is also set to approximately $7.5 \mu\text{A}$. However, as in the 2252, the level match will be affected by any additional currents drawn from the C_T pin.

Compressor (or Limiter) Configurations

The 4305 provides the two essential building blocks required for a wide variety of dynamics processing applications. The part may be configured into practically any type of dynamics processor system.

Perhaps the most common application for the 4305 is as a compressor or limiter. These circuits are intended to reduce gain above some determined signal level in order to prevent subsequent stages from being overloaded by too high a signal. Compressors generally have low to moderate compression ratios, while limiters have high ratios. In such applications, the signal path has static gain so long as the input signal remains below some threshold, but gain is reduced when the signal rises above the threshold. Compression ratio is defined as the number of dB the input signal increases for a 1 dB increase in output signal.

Feedforward Topologies

To make a compressor or limiter with a 4305, typically, the input signal is applied to both the VCA and the RMS detector. The RMS output signal is fed forward to the VCA's negative control port (E_c) via a dc-coupled op-amp based stage. This stage has gain above some dc level (the threshold), and no transmission below that level. This path, called the "sidechain," — from detector output to VCA control port — determines the compression behavior of the circuit. As signal level rises, the dc voltage at the RMS' output rises. Once the dc level exceeds the threshold, the rms output signal is transmitted through the sidechain and presented to the VCA control port, lowering the gain to signals passing

through the VCA. As a result, the output signal level is reduced, or compressed, relative to rising input signal levels.

Varying the threshold setting of the sidechain will vary the point at which compression begins. Varying the gain between the RMS output and the VCA control input varies the compression ratio.

Feedforward compressor topologies are especially versatile because they cannot become unstable due to oscillation in the control loop. Unity gain in the sidechain produces infinite compression (where the output remains constant regardless of increases in the input signal). With feedforward, negative compression ratios are easily achievable. (Negative compression occurs when the output signal decreases as the input signal increases.) This approximates the effect of playing music backwards, since the attack is suppressed and the release is increased in volume.

Many other variations of the feedforward concept are possible. These include implementing more than one threshold, different ratios, additional time constants, ac-coupling of some (or all) of the detector output signal, and many more. See AN101A, *The Mathematics of Log-Based Dynamic Processors*, for more details of how the sidechain gain determines compression ratios.

Feedback Topologies

An alternative configuration for compressor/limiter design is to feed the output signal into the RMS detector. The RMS output is fed back (dc-coupled) to the VCA's negative control port to reduce signal levels. Similarly as with a feedforward designs, a threshold in the sidechain serves to stop the compression action at low signal levels.

The feedback topology behaves somewhat differently from feedforward. First, reaching infinite compression requires infinite gain in the feedback loop from RMS output to VCA control port. Of course, infinite gain is impossible, so practical feedback compressors are usually limited to ratios no greater than 20 or so. Additionally, the gain in the feedback loop alters the effective time constant of the detector, shortening the attack as the ratio becomes higher. This may or may not be appropriate, depending on the desired effect.

Expander (Gate) Configurations

By changing the sign of the sidechain in a feedforward compressor, it is possible to arrange signal gain to decrease along with signal level, thus producing an expander. This is typically applied below a threshold (so, the threshold detector's polarity is reversed from that of a compressor) to reduce noise or crosstalk during pauses in program material. This technique has long been used for "cleaning up" individual drum tracks to reduce reverberation, interference from microphones picking up adjacent drum sounds, and alter the attack/decay characteristic of individual drum sounds.

Practical gates usually require very fast attack times, and carefully programmable release times. In a 4305, this is best accomplished by using the RMS detector as a log rectifier with very short time constants, and following the detector output with a time-constant stage that applies the desired attack and release behavior. This alters the 4305 detector's natural response characteristics to peak, rather than rms, time constants. We intend to produce an application note showing examples of these circuits. Until that is available, see DN 100, which shows a noise gate application using THAT's 4301 Analog Engine®.

Noise Reduction (Compander) Configurations

An additional application of the 4305 is for noise reduction systems. In these applications, one Analog Engine is configured for use as a compressor to condition audio signals before feeding them into a noisy channel. A second Analog Engine, configured as an expander, is located at the receiver end of the noisy channel. Most commonly, the compression/expansion ratio is modest (e.g. 2:1:2) and is linearly applied across the entire signal dynamic range.

During low-level audio passages, the compressor increases signal levels, bringing them up above the noise floor of the channel. At the receiving end, the expander reduces the signal back to its original level, in the process attenuating channel noise.

During high-level audio passages, the compressor decreases signal levels, reducing them to fit within the headroom limits of the channel. The expander increases the signal back to its original level. While the channel noise may be increased by this action, in a well-designed compander, at such

times the noise floor will be masked by the high-level signal.

The 4305 facilitates the design of a wide variety of companding noise reduction systems. The RMS detector responds accurately over a wide range of levels; the VCA responds accurately to a wide range of gain commands; and all the detector and VCA inputs, outputs, and control ports are independently accessible and fully configurable. All these features mean that the 4305 will support a wide range of compander designs, including simple 2:1 wide range (level-independent) systems, level-dependent systems with thresholds and varying compression slopes, systems including noise gating and/or limiting, and systems with varying degrees of pre-emphasis and filtering in both the signal and detector paths. Furthermore, much of this can be accomplished by extensively conditioning the control voltage sidechain rather than the audio signal itself. The audio signal can pass through as little as one VCA and one opamp, and still support multiple ratios, thresholds, and time constants.

Note that the 4305 is fully compatible with other Analog Engines from THAT Corporation. All our Analog Engines feature log-responding true-RMS level detectors and exponentially controlled Blackmer VCAs. It is possible to compress (encode) signals using the low-voltage, low-power 4315 or 4320 in a handheld, battery-operated device such as a wireless microphone or instrument belt pack, and expand (decode) that signal using the 4305 in a rack-mount, line-operated receiver.

The Mathematics of Log-Based Dynamics Processors

At first, the logarithmic output of the RMS detector and the exponential control ports of the VCA can be intimidating for designers unfamiliar with THAT Corporation's offerings. However, in fact, these characteristics make developing audio processors easy once a designer understands the concepts involved. As noted earlier, AN101A: *The Mathematics of Log-Based Dynamics Processors*, discusses these concepts in some detail. The following discussion draws heavily from that application note.

The Feedforward Compressor

Figure 3 shows a conceptual diagram of a very simple feedforward compressor. Using the "log

math" principles explained in AN101A, we can state that

$$Out_{dB} = In_{dB} + G_{dB} , \text{ and that}$$

$$G_{dB} = -k \cdot In_{dB} .$$

Note that the sign of k makes this a compressor in which gain G_{dB} decreases as input signal level In_{dB} increases. Combining these equations,

$$Out = In_{dB} - k \cdot In_{dB} = In_{dB}(1 - k) .$$

Rearranging yields

$$\frac{In_{dB}}{Out_{dB}} = \frac{1}{(1-k)} = C.R.$$

This is the compression ratio.

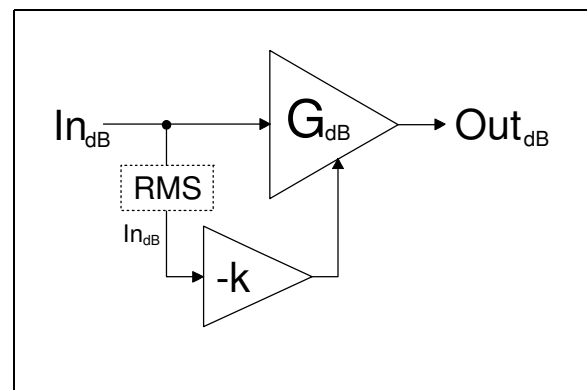

Figure 3. Simplified feedforward compressor

By inspection we can see that if k equals zero, the compression ratio will be 1:1, and if k equals 1, the compression ratio will be infinity:1. Thus, we can make a feedforward compressor/limiter by having the gain of the sidechain vary from zero to one.

Note that if $k > 1$, the compression ratio becomes negative. Negative compression results with $1 < k < 2$.

The Feedback Compressor

We can use the same approach for a feedback compressor. Figure 4 shows a simplified theoretical model of a feedback compressor. By inspection,

$$Out_{dB} = In_{dB} + G_{dB} , \text{ and}$$

$$G_{dB} = -k \cdot Out_{dB} . \text{ Therefore,}$$

$$Out_{dB} = In_{dB} - k \cdot Out_{dB}, \text{ and}$$

$$Out_{dB} + k \cdot Out_{dB} = In_{dB} . \text{ As such,}$$

$$\frac{In_{dB}}{Out_{dB}} = 1 + k = C.R.$$

In this case, as mentioned earlier, infinite compression requires infinite sidechain gain. Fortunately, compression ratios of between 10 and 20 limit effectively enough that infinite gain is not required.

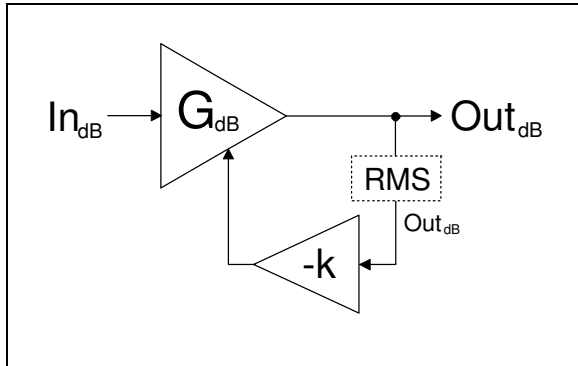

Figure 4. Simplified feedback compressor, conceptual diagram.

Log-Based Expanders

Similarly, for the feedforward expander shown in Figure 5, we can state that

$$Out_{dB} = In_{dB} + G_{dB} , \text{ and that}$$

$$G_{dB} = k \cdot In_{dB} .$$

Note that the sign of k makes this an expander in which gain GdB decreases as input signal level In dB decreases. Combining these equations:

$$Out_{dB} = In_{dB} + k \cdot In_{dB}, \text{ and}$$

$$Out_{dB} = (1 + k)In_{dB} .$$

Rearranging yields

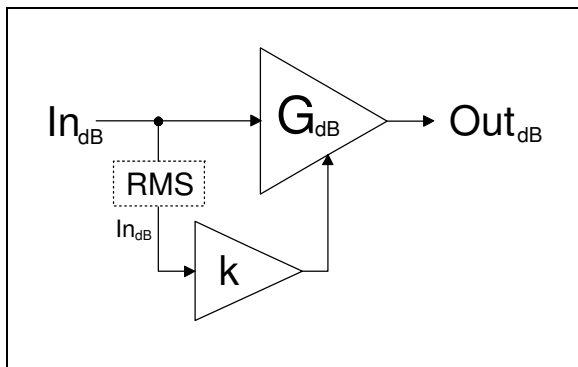

Figure 5. Simplified feedforward expander, conceptual diagram

$$\frac{Out_{dB}}{In_{dB}} = 1 + k = E.R.$$

This is the expansion ratio.

Adjusting the Level Match Point

In the equations so far, we have made the implicit assumption that the decibel reference level everywhere is that of the rms-level detector. This assumption simplifies the math, but it may not correspond to real-world reference levels such as 1V rms (0 dBV) or 0.775 V_{RMS} (0 dBu). Additionally, it is possible to offset the VCA's inherent behavior of producing unity (0 dB) current gain at 0 mV control voltage (E_{C+}-E_{C-}) by selecting asymmetrical voltage-to-current and current-to-voltage converting resistors (R3 and R2, respectively, in Figure 2).

Figure 6 allows for a VCA voltage gain offset of A_{dB}, as well as an offset (LM_{dB}) to vary the "level match" point of the RMS detector. Using similar "log math" from AN101A, we can state for Figure 6:

$Out_{dB} = In_{dB} + G_{dB} + A_{dB}$, where G_{dB} is the VCA's control port gain in dB, and A_{dB} is any static gain or attenuation (in dB) applied to the signal.

We can also state that:

$G_{dB} = -k (Out_{dB} - L.M._{dB})$, where L.M. is a varying dc voltage intended to change the system's zero dB reference point (often referred to as level match point) from that of the detector, and k is the gain of the sidechain.

Substituting the second equation into the first,

$$Out_{dB} = In_{dB} + k(L.M._{dB} - Out_{dB}) + A_{dB}, \text{ or}$$

$$Out_{dB} = In_{dB} + k \cdot L.M._{dB} - k \cdot Out_{dB} + A_{dB}, \text{ or}$$

$$Out_{dB} = \frac{In_{dB} + k \cdot L.M._{dB} + A_{dB}}{(1+k)} .$$

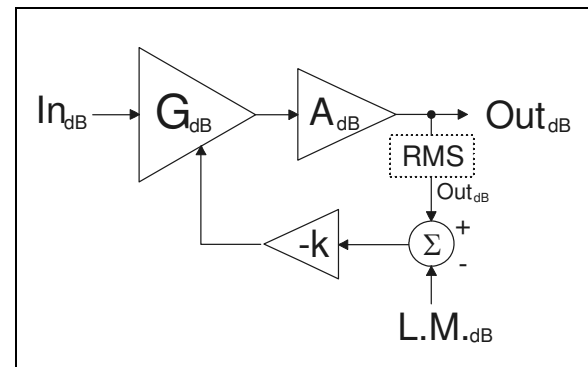

Figure 6. Feedback compressor with level match.

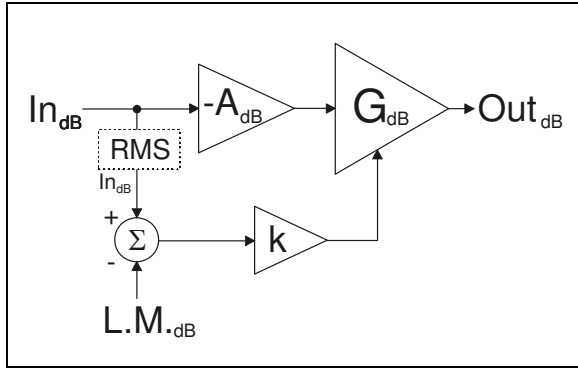

Figure 7. Feedforward expander with level match.

Similarly, for the expander shown in Figure 7, we can state that:

$$Out_{dB} = In_{dB} - A_{dB} + G_{dB}$$

$$G_{dB} = k(In_{dB} - L.M._{dB}). \text{ Thus:}$$

$$Out_{dB} = (1 + k)In_{dB} - k \cdot L.M._{dB} - A_{dB}$$

In both Figures 6 and 7, we show two ways to adjust the point at which input and output levels of the compressor or expander become equal. These are a) adjusting the 0 dB reference voltage level of the RMS detector by setting its voltage-to current converting resistor (R1 in Figure 2), and b) varying the static signal-path gain offset (A_{dB}). For the 4305, the best practice is to achieve level match via a combination of setting the RMS detector's voltage-to-current conversion, and offsetting the signal-path gain. Signal-path gain can be offset by altering the values of the VCA's voltage-to-current and current-to-voltage resistors. Both of these approaches have the advantage of being temperature-independent.

Figure 8 shows the behavior of the compressor of Figure 6 with varying sidechain gain k for a constant A_{dB} and LM_{dB} . Note that as k increases, the compression ratio increases, and the dynamic range of output levels decreases. Low input signal levels (including noise) are increased, and high input signal levels are decreased. Figure 9 shows how the same compressor behaves with varying LM_{dB} , but fixed A_{dB} and k . Note that as LM_{dB} is reduced, all output levels decrease, and vice-versa.

Figures 10 and 11 show how the input-output transfer characteristics of the expander of Figure 7 change while varying k (Fig 10) and LM (Fig 11). In each case, all other parameters remain fixed.

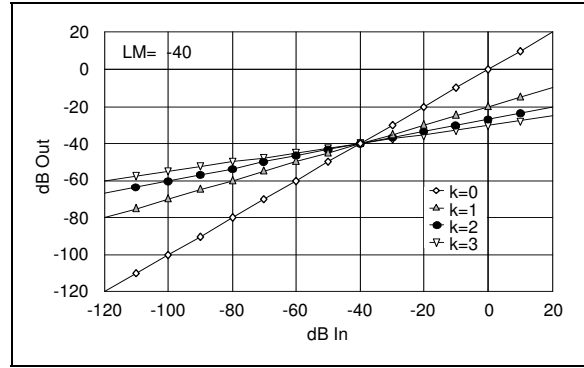

Figure 8. Compressor input-output transfer characteristics with varying k .

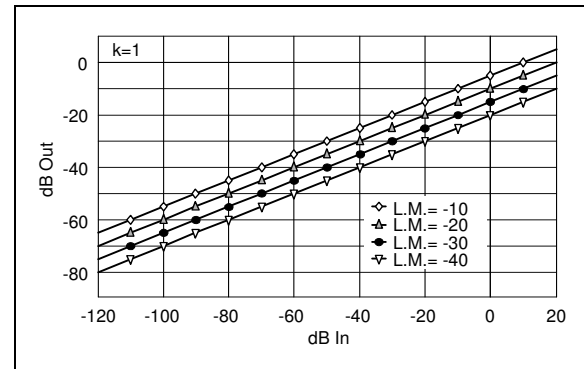

Figure 9. Compressor input-output transfer characteristics with varying LM_{dB}

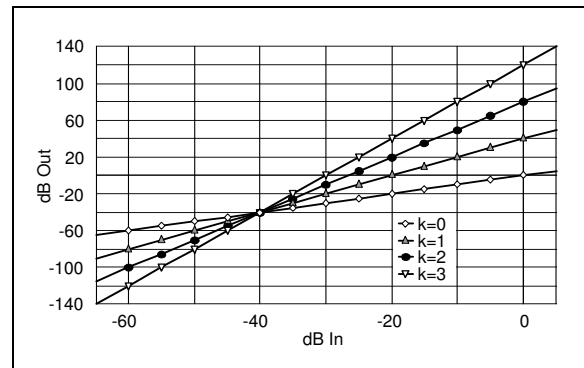

Figure 10. Expander input-output transfer characteristics with varying k .

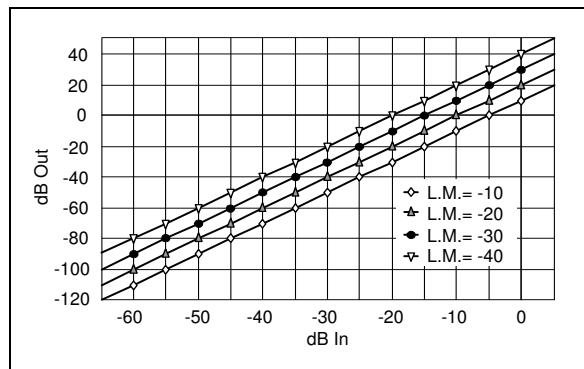

Figure 11. Expander input-output transfer characteristics with varying LM_{dB}

Compressors with Thresholds

The compressor of Figure 6 and expander of Figure 7 form the primary basis for the linear companding systems used in many audio applications. However, they are limited in application, since the compression ratio is linear over the entire dynamic range of the applied signal. While this is fine for companding systems, it is impractical for an effects compressor, not least due to the way very low-level signals -- including noise -- are raised in gain by the compressor's actions. A more practical approach to effects compressors is shown in Figure 12, which offers control over the threshold of compression and gain offset (or "makeup gain") in addition to the ratio.

In Figure 12, we've extended this approach to model a compressor with more of the features one would expect in an effects compressor/limiter. This model has a threshold adjustment (T_{dB}), a threshold (set by the ideal diode), a means to vary the sidechain gain (k), and a make-up gain adjustment (A_{dB}). As with the previous equations, all these variables are expressed in decibels, in keeping with the simple "log math" of AN101A.

As with all the previous figures,

$$Out_{dB} = In_{dB} + G_{dB}$$

For input signals above the level determined by the threshold setting,

$$In_{dB} > T_{dB} .$$

So, for signals above this level,

$$G_{dB} = -k(In_{dB} - L.M. - T.A.) + A_V .$$

Substituting yields

$$Out_{dB} = In_{dB} - k(In_{dB} - L.M. - T.A.) + A_V .$$

For input signals below the level set by the threshold setting, the signal at the output of the ideal diode threshold is 0 (dB), so

$$G_{dB} = A_{dB} , \text{ thus,}$$

$$Out_{dB} = In_{dB} + A_{dB} .$$

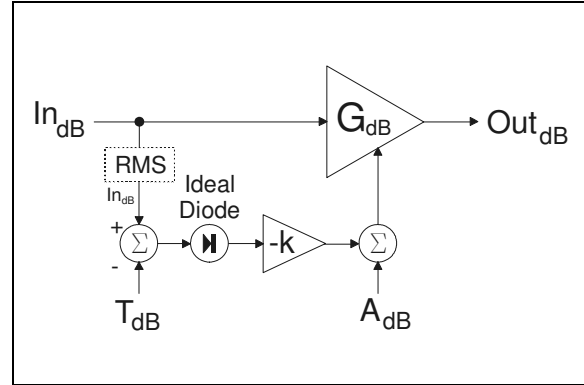

Figure 12. Feedforward compressor with threshold (T), gain (A), and ratio (k) adjustments

In the circuit of Figure 12, static gain offset is applied via a dc voltage summed into the sidechain and applied to the VCA control port. This illustrates an alternative method of varying VCA gain (different from offsetting the V-I and I-V converting resistors as mentioned earlier). This is especially convenient when the level match must be varied by the user, as with a front-panel control. Note, however, that since the VCA gain scale factor varies slightly with temperature (+0.33%/°C), the level match point will vary slightly with temperature unless the applied voltage is appropriately compensated.

If we let $T_{dB}=20$, $A_{dB}=0$ dB, and $k=0.75$, this behavior yields the transfer function shown in Figure 13. As predicted by the above equations, this results in a 4:1 compression ratio above the threshold of -20 dB (relative to the RMS detector's 0 dB reference level). The output level increases by 10 dB over a 40 dB change in input level.

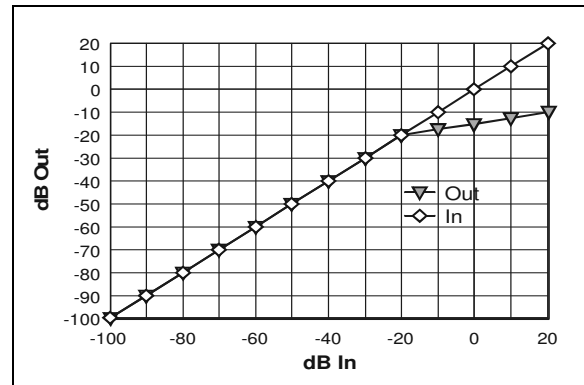

Figure 13. Transfer function of feedforward compressor

In Figure 14, we have again extended the basic feedback compressor with a threshold adjustment (T_{dB}), a threshold (the ideal diode), a means to vary the sidechain gain (k), and a make-up gain adjustment (A_{dB}) just as in Figure 8. However, in this case, the detector level is based on the compressor's output.

Once again we start with

$$Out_{dB} = In_{dB} + G_{dB}$$

For output signals above the level determined by the threshold setting,

$$Out_{dB} > T_{dB} .$$

So for signals above the threshold,

$$G_{dB} = -k(Out_{dB} - T_{dB}) + A_{dB} .$$

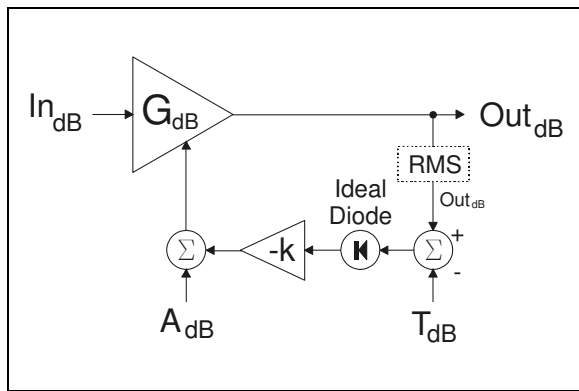

Figure 14. Feedback compressor with threshold (T), gain (A), and ratio (k) adjustments

Substituting yields

$$Out_{dB} = In_{dB} - k(Out_{dB} - T_{dB}) + A_{dB} ,$$

which can be reduced to

$$Out_{dB} = \frac{In_{dB} + T_{dB} + A_{dB}}{(1+k)} .$$

For output signals below the level set by the threshold setting, the signal at the output of the ideal diode threshold is 0 (dB), so

$$G_{dB} = A_{dB} , \text{ and}$$

$$Out_{dB} = In_{dB} + A_{dB}$$

If we let $T_{dB}=10$, $A_{dB}=20$, and $k=10$, this behavior yields the transfer function shown in Figure 15. The compression ratio of 11:1 allows a rise of only about 4.5 dB over a 50 dB range.

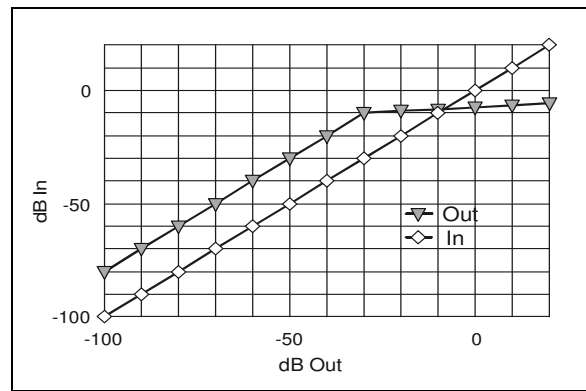

Figure 15. Transfer function of feedback compressor

Applications

In this datasheet, we will show detailed circuits for the 4305 in a relatively simple above-threshold compressor, and in two simple companding systems. As mentioned above, many other configurations of the 4305 are possible. THAT intends to publish additional circuits in forthcoming applications notes. Please check with THAT's applications engineering department to see if your application has been covered yet, and for personalized assistance with specific designs.

Feedforward Compressor/Limiter

The circuit in Figure 16 shows a typical hard-knee, feedforward compressor/limiter. In addition to compression ratio, the sidechain includes controls for threshold and make-up gain as well.

The Signal Path

The input of the VCA (pin 15) is a virtual ground, and R14 converts the input signal into a current flowing into the VCA. The maximum total signal current, ($I_{IN} + I_{OUT}$) is 1.8 mA with ± 15 V supplies, so R14 is sized to keep the maximum current at unity gain to below this level. With peak input voltage swing limited by the ± 15 V supply rails, the 20 k Ω resistor at R14 limits maximum i_{IN} to about 750 μ A. At 0 dB gain, this will cause the

same current at the VCA output, which is converted back to 15 V by U2 and R13 (also 20 k Ω). C2 provides AC coupling, required to block any DC currents that might otherwise flow into the VCA input. This prevents changes in gain from modulating this current, which could produce audible "thumps".

The compensation circuit of R28 and C16 is required for stability. The VCA must "see" a source impedance no greater than 5 k Ω above 1 MHz. R28 in parallel with R14 accomplishes this. C16 is chosen to prevent the added noise gain of the lower source impedance from increasing noise within the audio band.

Note that such compensation is unnecessary when the voltage-to-current converting resistor (R14) is 5 k Ω or less. For example, if the input signal were limited to lower voltages, the input voltage-to-current converting resistor (R14) could be reduced in value, possibly eliminating the need for R28 and C16.

U2, along with C4 and R13 forms a trans-impedance amplifier that converts the VCA's output current into a voltage. C4 prevents the VCA's output capacitance from destabilizing the op-amp in this configuration.

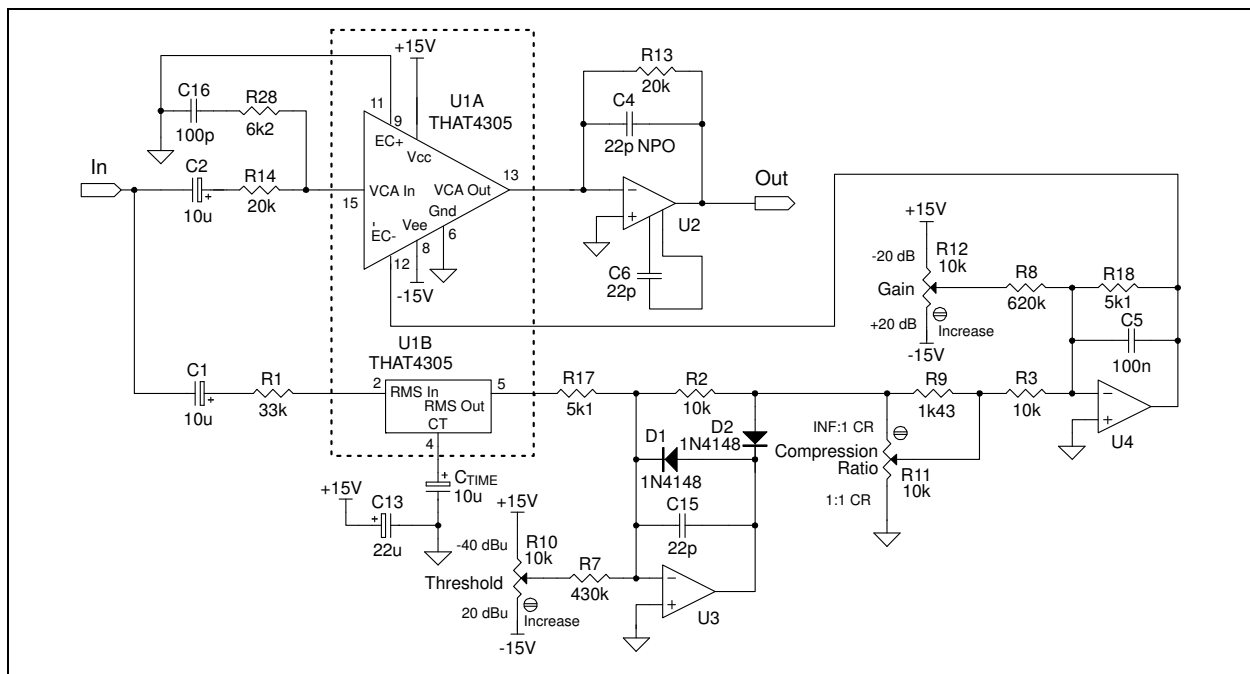

Figure 16. 4305-based feedforward compressor

The Sidechain

As noted earlier, for most effects compressors, it is best not to linearly compress the entire dynamic range of the audio signal. To this end, in the sidechain of figure 16, we have added a threshold amplifier with ± 30 dB of threshold adjustment. This restricts compression to signals above the threshold, passing those below threshold without any change. Additionally, we added a compression ratio control adjustable from 1:1 to ∞ :1. Finally, we've added a means to apply up to ± 20 dB of static, or "make-up" gain.

The input signal is fed into the RMS detector through C1 and R1. Like the VCA, the input to the detector is AC coupled. This prevents any DC current flowing into the detector's input from being measured by the detector. If unchecked, such offsets would limit resolution at low levels, producing an artificial "floor" to the detector's low-level response.

As previously discussed (in the theory section), the output of the detector is proportional to the log of the RMS level of the input voltage. The output of the detector will be approximately zero volts at the "zero dB reference level" -- the point at which the RMS value of the input current equals the timing current (set at $7.5 \mu\text{A}$ for the 4305). We have chosen a value of -10 dBu, ($245 \text{ mV}_{\text{RMS}}$) for the zero dB reference level. The required input resistor can be calculated as

$$R = \frac{245 \text{ mV}_{\text{RMS}}}{7.5 \mu\text{A}} = 32.6 \text{ k}\Omega \approx 33 \text{ k}\Omega .$$

Inverting threshold amplifier (U3) provides gain of approximately -2 to the detector output signal above threshold, and zero gain ($A_v=0$) to signals below threshold. The change in gain is accomplished by D1 and D2, which allow negative-going output signals to pass but block positive-going ones. Because U3 is configured to invert, positive-going signals at the RMS output (indicating increasing ac input levels) are passed onwards, while negative-going RMS outputs are blocked. By feeding variable dc into this stage via R7 and the threshold pot R10, we can vary the point at which RMS output signals begin to be passed through to the threshold amplifier stage's output (at the junction of D2 and R2.)

The scaling at the output of the detector is +6.2 mV/dB, but because R2 is approximately twice R17, the threshold amplifier (U3) has a gain of -2, so

the scaling at its output is -12.4 mV/dB. To swing the threshold over ± 30 dB, we can calculate the required value of R7 as follows:

$$\frac{15 \text{V} \left(\frac{10 \text{k}\Omega}{R7} \right)}{0.0124 \frac{\text{V}}{\text{dB}}} = 30 \text{dB} .$$

We can rearrange this to be

$$\frac{10 \text{k}\Omega}{R7} = \frac{30 \text{dB}}{15 \text{V}} \cdot 0.0124 \frac{\text{V}}{\text{dB}} . \text{ and therefore,}$$

$$R7 = 403.2 \text{ k}\Omega$$

We chose 430 k Ω for R7.

U4 is a variable-gain inverter that serves to buffer the VCA's control port, ensuring a low-impedance drive at that point. (High impedances, even as little as 50 to 100 ohms, will increase VCA distortion at high signal levels.) Above threshold, when U4's gain is $-1/2$, the net gain of the sidechain (from RMS output to VCA control input) is unity, and the compression ratio is ∞ :1. The network of R3, R9, and R11 in conjunction with R18, allows the gain of U4 to vary from 0 to $-1/2$, and simultaneously shapes the (linear) pot's response so that 50% rotation results in 4:1 compression. 4:1 ratio at 50% rotation is often considered a useful target.

Finally, R8 and R12 provide the means for adding static, or "make-up" gain. The control-voltage sensitivity at the output of U4 is 6.2 mV/dB. Therefore,

$$\frac{15 \text{V} \left(\frac{5.1 \text{k}\Omega}{R8} \right)}{0.0062 \frac{\text{V}}{\text{dB}}} = 20 \text{dB} .$$

We can rearrange this to be

$$\frac{5.1 \text{k}\Omega}{R8} = \frac{20 \text{dB}}{15 \text{V}} \cdot 0.0062 \frac{\text{V}}{\text{dB}} , \text{ and therefore,}$$

$$R8 = \frac{5 \text{k}\Omega}{\frac{20 \text{dB}}{15 \text{V}} \cdot 0.0062 \frac{\text{V}}{\text{dB}}} = 625 \text{ k}\Omega$$

We've chosen 620 k Ω for R8 since it is the nearest 5% value.

The signals in the sidechain, and at the output of U4, are generally relatively slow moving, so the sidechain does not usually require wide bandwidth. Furthermore, noise on the VCA control port can modulate the VCA signal, thus adding noise to the signal path. Accordingly, we added C5 in order

reduce the noise gain of U4 at high frequencies, which slightly reduces the high-frequency noise floor of the entire circuit. C5 may be omitted for non-critical applications.

As described in the Theory of Operation section ("The RMS Detector - In Brief"), the RMS detector is capable of driving large spikes of current into the averaging capacitor C_{TIME}. To prevent these currents from upsetting circuit grounds, it is necessary to bypass V_{CC} to a point very near the grounded end of C_{TIME} with a capacitor equal to or greater than the value of C_{TIME}. This is C13 in Figure 16. The grounded ends of these two capacitors should be connected together before being tied to the rest of the ground system. Doing so will ensure that the current spikes flow within the local loop consisting of the two capacitors, and stay out of the ground system.

Comping Systems

The Encoder

Figure 17 shows the 4305 configured as a simple 2:1 encoder or feedback compressor. The encoder in a companding system is positioned before the noisy channel (wireless link, storage system,

etc.). The static gain of this circuit is 1, or zero dB, and a 5.1 kΩ resistor (R3) along with a 220 pF capacitor (C4) comprise the compensation network is required to keep the VCA's input amplifier stable for all gains.

Since the RMS detector output is tied directly to the VCA's E_c, the compression ratio will be 2:1. Note that the use of the negative-sense control port, E_c, makes this circuit a compressor. The RMS detector timing capacitor is set for a release rate of -125 dB per second by using a value of 10 μF.

C5 serves to keep high currents through the timing capacitor (C3) from upsetting circuit grounds as described in the previous section.

The output of the RMS detector is zero volts when the RMS input current is equal to the timing current (internally set to ~7.5 μA). A voltage level of -28.5 dBV was chosen as the desired zero dB reference. The RMS detector's input resistance can be calculated as:

$$R_{RMS In} = \frac{10^{\frac{-28.5}{20}}}{7.5 \mu A} \approx 5.1 k\Omega .$$

This value also applies to the decoder.

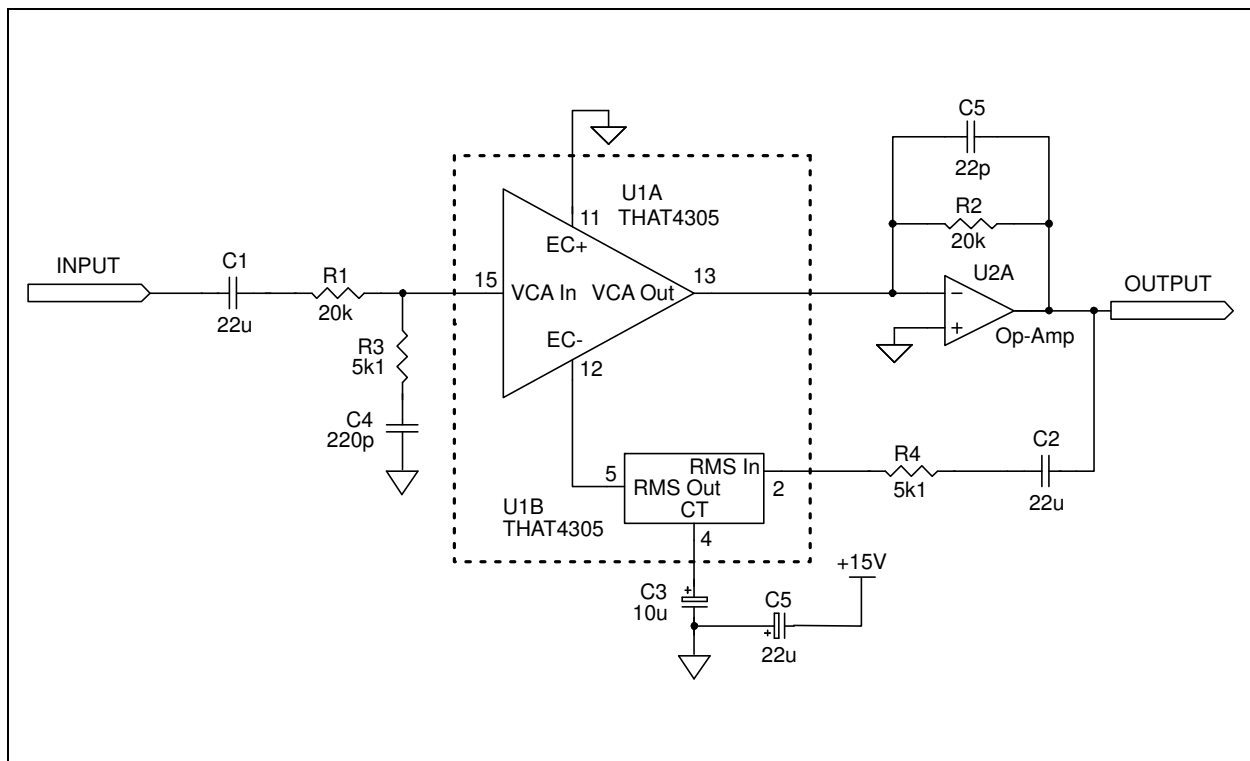

Figure 17. 4305 simple compander circuit - 2:1 encoder (compressor)

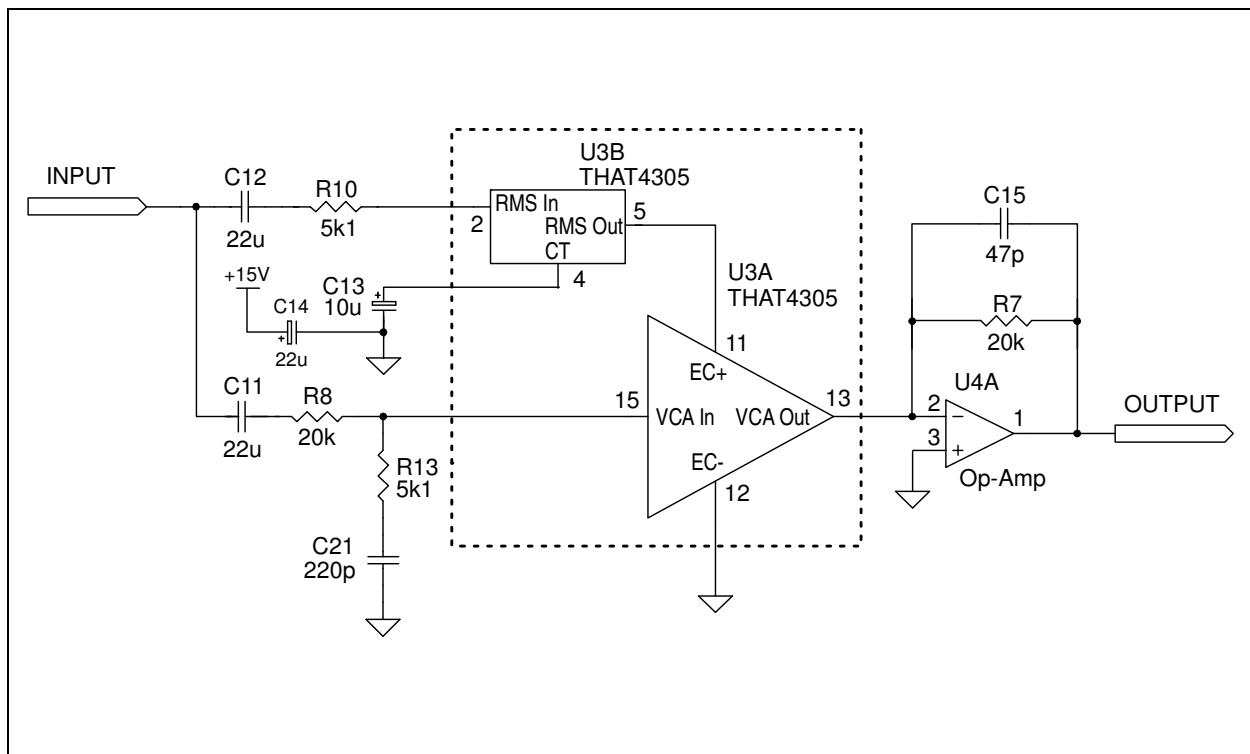

Figure 18. 4305 typical application circuit - 1:2 expander

The Decoder

Figure 18 shows the THAT4305 configured as a 1:2 expander intended to complement the encoder in Figure 17.

This circuit also uses a static gain of zero dB. Since the VCA is not stable unless it sees a high frequency source impedance of 5 kΩ or less, the compensation network of R13 and C21 ensures stability.

In this instance, the RMS detector output is connected to EC+; this reverses the polarity of the control signal relative to the encoder, and makes this circuit a 2:1 expander.

System Performance

Table 3 shows the transfer characteristics of this companding system. The columns labeled Encoder VCA Gain, Encoder Out, Decoder VCA Gain, and Decoder Out use the equations derived previously in the Theory sub-section entitled "The Mathematics of Log Based Companding Systems". The values in the column labeled I_{RMS In} are derived using the equation:

$$I_{RMS In} = \frac{10^{\left(\frac{EncoderOut}{20}\right)}}{R_{RMS In}}$$

The required encoder VCA gain range is -24 dB to +36 dB, and the required decoder VCA gain range is -36 dB to +14 dB. These gains are easily within the capabilities of the 4305's VCA. The range of RMS input currents is easily accommodated at the high end, though accuracy may be slightly compromised at the lowest input levels.

Encoder In	Encode VCA Gain	Encoder Out/Decoder In	I _{RMS In}	Decoder VCA Gain	Decoder Out
(dBV)	(In dB)	(dBV)	(mA)	(In dB)	(dBV)
20	-24	-4	0.1223	24	20
10	-19	-9	0.0688	19	10
0	-14	14	0.0387	14	0
-10	-9	-19	0.0218	9	-10
-20	-4	-24	0.0122	4	-20
-30	1	-29	0.0069	-1	-30
-40	6	-34	0.0039	-6	-40
-50	11	-39	0.0022	11	-50
-60	16	-44	0.0012	16	-60
-70	21	-49	0.0007	-21	-70
-80	26	-54	0.0004	-26	-80
-90	31	-59	0.0002	-31	-90
-100	36	-64	0.0001	-36	-100

Table 3. 2:1 compander transfer characteristics

Figure 19 tracks signal levels through the encoder and decoder of Figures 17 and 18. The encoder reduces the dynamic range at its input by a factor of 2, compressing 120 dB into 60 dB. The decoder expands this dynamic range back to track that of the encoder's input signal.

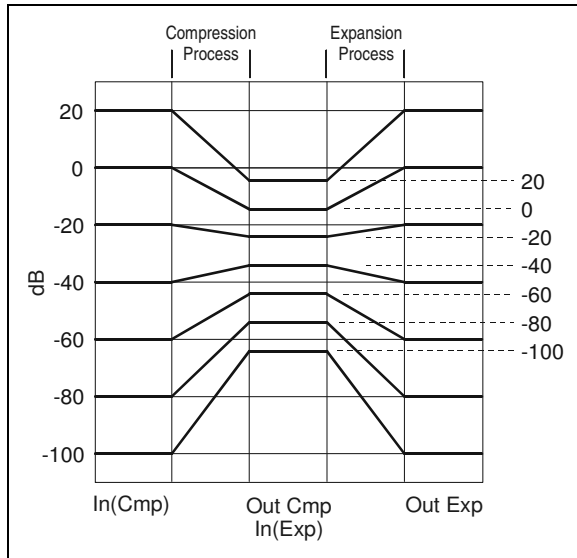

Figure 19. 2:1 compander transfer characteristics

Hi-fi Compressor

While the previous circuits perform adequately in some applications, a few minor changes can result in substantially improved overall performance. The following compressor implementation adds pre- and de-emphasis to the signal path. Signal path pre-emphasis helps overcome the rising noise level with frequency of an FM RF channel by raising the level of the high frequency portions of the signal before it passes through the transmission channel. Matching signal-path de-emphasis in the decoder brings the frequency response back to flat while simultaneously lowering the noise floor of the channel. This helps ensure that isolated low-frequency signals mask the channel noise by reducing the perception of high-frequency noise signals.

Of course, the drawback of signal-path pre-emphasis is that it can cause overload in the channel when high-level, high-frequency signals are present. To guard against this problem, we have added RMS pre-emphasis to both detectors. This mitigates high-frequency overload by lowering the level-match point to high-frequency signals. For a

given signal level, high-frequency signals are lowered in level by the VCA more than low-frequency signals.

As an additional enhancement, we have included a means to truncate the RMS detector's low-level response. This improves low level tracking between different detectors by forcing each detector to "bottom out" at a predetermined level, eliminating the effects of different low-level behavior from one detector to the next.

System Performance

The compressor shown in Figures 20 and 21 implements all of the aforementioned improvements. Assuming no change in VCA gain (G_{dB}), the pre-emphasis network of R3 and C7 produces ~20 dB of signal-path pre-emphasis starting at ~2 kHz and stopping at ~19 kHz.

Note that R3 and C7 also compensate the input to the VCA, so additional components are not required to implement this feature. Signal fed to this network is buffered by U2; while this buffer is not always necessary, the pre-emphasis network must be driven from a low source impedance to ensure proper tracking between the encoder pre-emphasis and the decoder de-emphasis. If driven from an unbuffered source, the pre-emphasis network should be adjusted to take into account the impedance of that source.

We have included ~10 dB of RMS pre-emphasis (provided by R5 and C8 in the encoder, and R11 and C18 in the decoder) for the detectors in both the encoder and the decoder. The center frequency of this pre-emphasis circuit is aligned with the center frequency of the signal path pre-emphasis when evaluated on a logarithmic frequency scale. This shifts the level match of the encoder symmetrically about the mid-point of the signal-path pre-emphasis, which configures the system to take the best advantage of the compressing to avoid high-level high-frequency overload in the transmission or storage channel.

R6 of the Hi-Fi encoder and R12 of the decoder are intended to force each of the detectors to stop responding to low level signals at the same point in order to improve tracking. This floor occurs when the RMS current through R1 equals that of R6, and when the current through R10 equals that of R12. Since the input of the RMS detector is at virtual ground, the current through R6 and R12 will be

$$i_{R_6} = \frac{RMSOut}{R_6} , \text{ and}$$

$$i_{R_{12}} = \frac{RMSOut}{R_{12}}$$

We'll choose a point about 6 dB above the encoder output level (-56 dBV) corresponding with an input level of -100 dBV.

$$V_{IN} = 10^{\left(\frac{-50dBV}{20}\right)} = 3.16mV_{RMS} . \text{ Therefore,}$$

$$\frac{0.00316V}{8.87k\Omega} = \frac{(-23.6 - (-50)) \cdot 0.0062}{R_6} , \text{ And}$$

$$R_6 = \frac{(-23.6 - (-50)) \cdot 0.0062}{\frac{0.00316V}{8.87k\Omega}} = 459k\Omega \approx 464k\Omega$$

The same is true for R12.

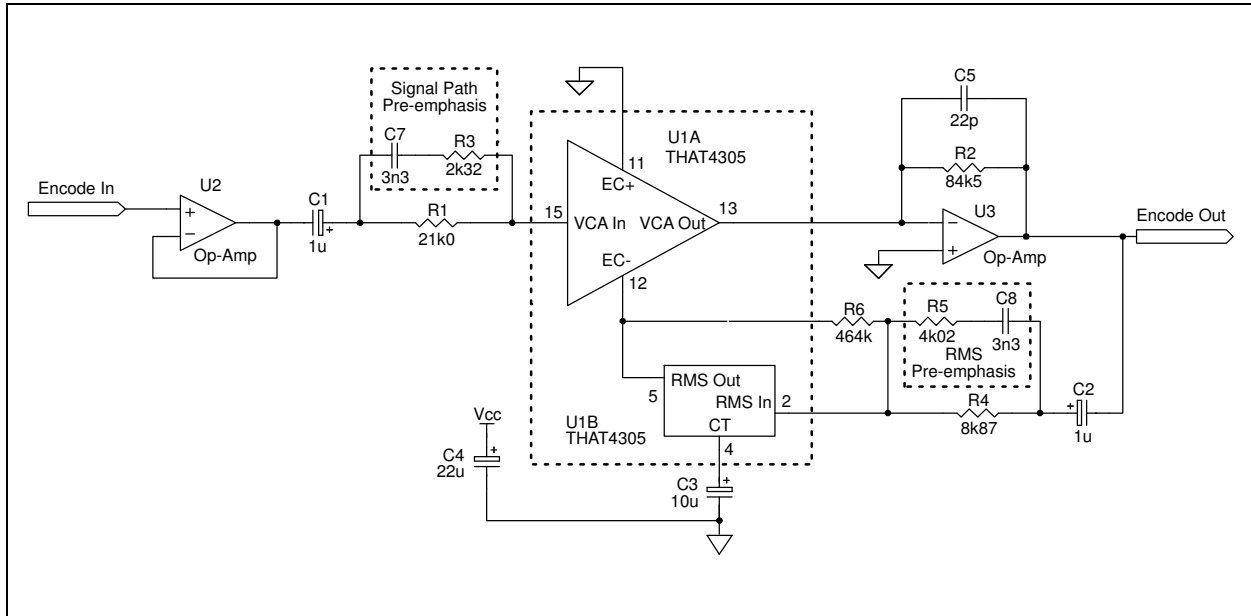

Figure 20. 4305 hi-fi 2:1 encoder circuit

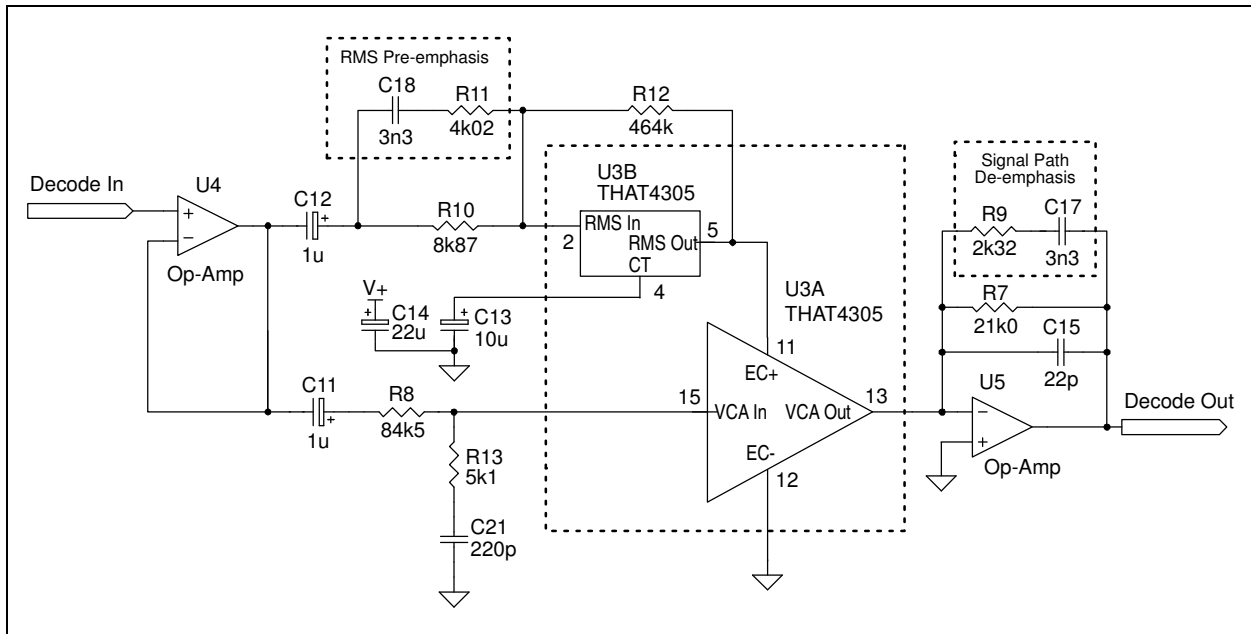

Figure 21. 4305 hi-fi 2:1 decoder circuit

Encoder In	Encode VCA Gain	Encoder Out/Decoder In	$I_{RMS\ In}$	Decoder VCA Gain	Decoder Out
(dBV)	(ln dB)	(dBV)	(mA)	(ln dB)	(dBV)
20	-28	-4	0.1841	28	20
10	-23	-1	0.1035	23	10
0	-18	-6	0.0582	18	0
-10	-13	-11	0.0327	13	-10
-20	-8	-16	0.0184	8	-20
-30	-3	-21	0.0104	3	-30
-40	2	-26	0.0058	-2	-40
-50	7	-31	0.0033	-7	-50
-60	12	-36	0.0018	-12	-60
-70	17	-41	0.0010	-17	-70
-80	22	-46	0.0006	-22	-80
-90	27	-51	0.0003	-27	-90
-100	32	-56	0.0002	-32	-100

Table 4. Hi-fi compander transfer characteristics (applies to low frequencies only)

Table 4 shows the transfer characteristics of this companding system (neglecting the effects of R6 and R12). As before, the columns labeled Encoder VCA Gain, Encoder Out, Decoder VCA Gain, and Decoder Out use the equations derived previously in the section titled "The Mathematics of Log Based Companding Systems". The values in the column labeled RMS In are derived using the equation:

$$I_{RMS\ In} = \frac{10^{\left(\frac{Encoder\ Out}{20}\right)}}{R_{RMS\ In}}$$

Figure 22 tracks signal levels through the encoder and decoder of Figures 20 and 21. The compression and expansion ratios here are the same as those of the previous circuits, but the frequency shaping afforded by signal pre- and de-emphasis and detector pre-emphasis make this a superior sounding system.

In this application, the VCA gain ranges over about ± 30 dB, which is well within specification, as is the RMS detector input current.

Other Dynamics Processor Configurations

We have said before that the building blocks contained within the 4305 are applicable to a very

wide range of dynamics processor configurations. These include companding noise reduction systems with ratios other (higher or lower) than 2:1:2, multi-band compressors, etc. The 4305 is versatile enough to be used as the heart of a compressor, expander, noise gate, AGC, de-esser, frequency-sensitive compressor, and many other dynamics processors. It is beyond the scope of this data sheet to provide specific advice about any of these functional classes. We refer the interested reader to THAT's applications notebooks volumes 1 and 2, which contain many circuits based on THAT's other VCAs and RMS level detectors, but are largely applicable to the 4305 with only minor variations. Of course, look for more applications information aimed specifically at the 4305 in the future.

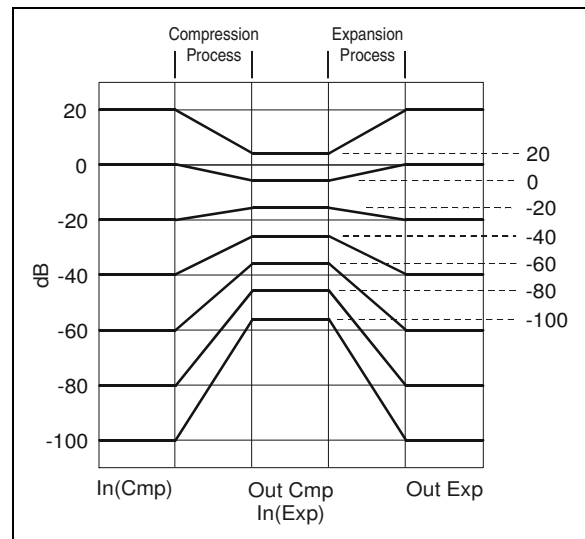

Figure 22. Hi-fi compander transfer characteristics

Closing Thoughts

The design of dynamics processors and companding systems is a very intricate art: witness the proliferation of dynamics processors available in the market today. Many of these are based on THAT's VCAs and level detectors, yet they all have individual sonic characteristics. In the applications section of this data sheet, we have offered a few examples only as starting points. THAT Corporation's applications engineering department is ready to assist customers with suggestions for tailoring and extending these basic circuits to meet specific needs.

Package and Soldering Information

The THAT 4305 is available in a 16-pin QSOP package. The package dimensions are shown in Figure 23 below, while the pinout is given in Table 1 on page 1.

The 4305 is available in a lead-free, "green" package. The lead frame is copper, plated with successive layers of nickel palladium, and gold. This approach makes it possible to solder these devices using lead-free and lead-bearing solders. The plastic mold compound, and the material in which the parts are packaged, contains no hazardous substances as

specified in the RoHS directive. For more information, including MDDS forms which disclose the substances contained in our ICs and their packaging, please visit: www.thatcorp.com/RoHShome.html.

The package has been qualified using reflow temperatures as high as 260°C for 10 seconds. This makes them suitable for use in a 100% tin solder process. Furthermore, the 4305 has been qualified to a JEDEC moisture sensitivity level of MSL1. No special humidity precautions are required prior to flow soldering the parts.

<u>Package Characteristics</u>						
Parameter	Symbol	Conditions	Min	Typ	Max	Units
Package Style		See Fig. 23 for dimensions		16 Pin QSOP		
Thermal Resistance	θ_{JC}	SO package in ambient		105		°C/W
Thermal Resistance	θ_{JA}	SO package soldered to board		40		°C/W
Environmental Regulation Compliance		Complies with RoHS requirements				
Soldering Reflow Profile		JEDEC JESD22-A113-D (250 °C)				

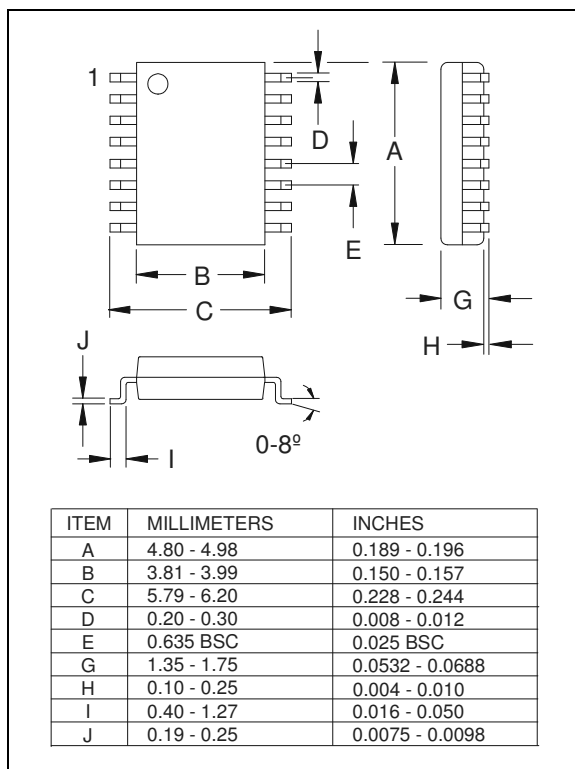

Figure 23. QSOP-16 surface mount package drawing

Notes: