

# VS1011b - MP3 AUDIO CODEC

## Features

- Decodes MPEG 1 & 2 audio layer 3 (ISO 11172-3), WAV and PCM files
- Supports VBR (variable bitrate) for MP3
- Stream support
- Can be used as a slave co-processor
- Operates with single clock 12.288..14 MHz or 24.576..28 MHz.
- Low-power operation
- High-quality stereo DAC with no phase error between channels
- Stereo earphone driver capable of driving a  $30\Omega$  load
- Separate 2.5 .. 3.6V operating voltages for analog and digital
- 5.5 KiB On-chip RAM for user code / data
- Serial control and data interfaces
- New functions may be added with software and 4 GPIO pins

## Description

VS1011b is a single-chip MP3 audio decoder. The chip contains a high-performance, low-power DSP processor core VS\_DSP<sup>4</sup>, working memory, 5 KiB instruction RAM and 0.5 KiB data RAM for user applications, serial control and input data interfaces, 4 general purpose I/O pins, as well as a high-quality variable-sample-rate stereo DAC, followed by an earphone amplifier and a ground buffer.

VS1011b receives its input bitstream through a serial input bus, which it listens to as a system slave. The input stream is decoded and passed through a digital volume control to an 18-bit over-sampling, multi-bit, sigma-delta DAC. The decoding is controlled via a serial control bus. In addition to the basic decoding, it is possible to add application specific features, like DSP effects, to the user RAM memory.

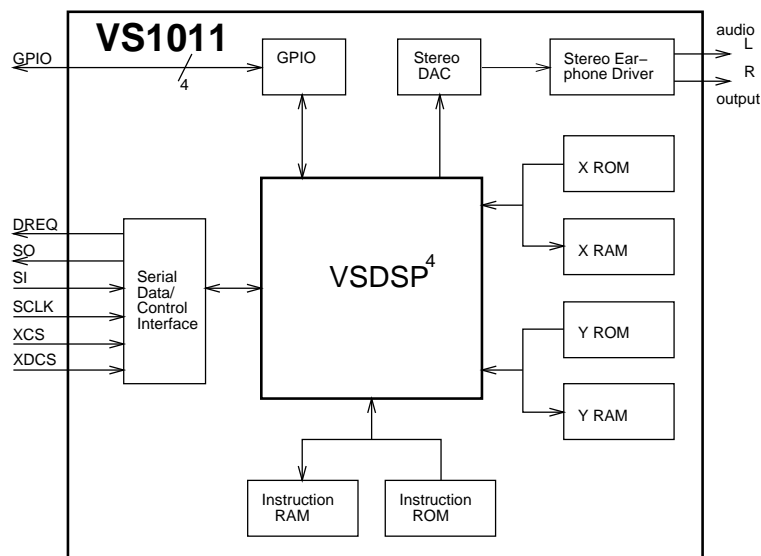

## Contents

<b>1 License</b>	<b>8</b>
<b>2 Disclaimer</b>	<b>8</b>
<b>3 Definitions</b>	<b>8</b>
<b>4 Characteristics &amp; Specifications</b>	<b>9</b>
4.1 Analog Characteristics . . . . .	9
4.2 Power Consumption . . . . .	10
4.3 DAC Interpolation Filter Characteristics . . . . .	10
4.4 Absolute Maximum Ratings . . . . .	10
4.5 Recommended Operating Conditions . . . . .	11
4.6 Digital Characteristics . . . . .	11
4.7 Switching Characteristics - Clocks . . . . .	12
4.8 Switching Characteristics - DREQ Signal . . . . .	12
4.9 Switching Characteristics - SPI Interface Output . . . . .	12
4.10 Switching Characteristics - Boot Initialization . . . . .	12
<b>5 Packages and Pin Descriptions</b>	<b>13</b>
5.1 Packages . . . . .	13
5.1.1 LQFP-48 . . . . .	13
5.1.2 BGA-49 . . . . .	13
5.1.3 SOIC-28 . . . . .	14
5.2 Pin Descriptions . . . . .	15
5.2.1 LQFP-48 and BGA-49 Pin Descriptions . . . . .	15

5.2.2	SOIC-28 Pin Descriptions . . . . .	16
<b>6</b>	<b>Connection Diagram, LQFP-48</b>	<b>17</b>
<b>7</b>	<b>SPI Buses</b>	<b>18</b>
7.1	General . . . . .	18
7.2	SPI Bus Pin Descriptions . . . . .	18
7.2.1	VS1002 Native Modes (New Mode) . . . . .	18
7.2.2	VS1001 Compatibility Mode . . . . .	18
7.3	Serial Protocol for Serial Data Interface (SDI) . . . . .	19
7.3.1	General . . . . .	19
7.3.2	SDI in VS1002 Native Modes (New Mode) . . . . .	19
7.3.3	SDI in VS1001 Compatibility Mode . . . . .	19
7.3.4	SDI and DREQ . . . . .	20
7.4	Serial Protocol for Serial Command Interface (SCI) . . . . .	20
7.4.1	General . . . . .	20
7.4.2	SCI Read . . . . .	21
7.4.3	SCI Write . . . . .	21
7.5	SPI Timing Diagram . . . . .	22
7.6	SPI Examples with SM_SDINEW and SM_SDISHARED set . . . . .	23
7.6.1	Two SCI Writes . . . . .	23
7.6.2	Two SDI Bytes . . . . .	23
7.6.3	SCI Operation in Middle of Two SDI Bytes . . . . .	23
<b>8</b>	<b>Functional Description</b>	<b>24</b>
8.1	Main Features . . . . .	24

8.2	Supported Audio Codecs . . . . .	24
8.2.1	Supported MP3 (MPEG layer 3) Formats . . . . .	24
8.2.2	Supported RIFF WAV Formats . . . . .	25
8.3	Data Flow of VS1011b . . . . .	25
8.4	Serial Data Interface (SDI) . . . . .	26
8.5	Serial Control Interface (SCI) . . . . .	26
8.6	SCI Registers . . . . .	26
8.6.1	SCIMODE (RW) . . . . .	27
8.6.2	SCI_STATUS (RW) . . . . .	28
8.6.3	SCIBASS (RW) . . . . .	28
8.6.4	SCICLOCKF (RW) . . . . .	29
8.6.5	SCIDECODE_TIME (RW) . . . . .	29
8.6.6	SCILAUDATA (RW) . . . . .	30
8.6.7	SCIWRAM (RW) . . . . .	30
8.6.8	SCIWRAMADDR (RW) . . . . .	30
8.6.9	SCI_HDAT0 and SCI_HDAT1 (R) . . . . .	31
8.6.10	SCIAIADDR (RW) . . . . .	32
8.6.11	SCIVOL (RW) . . . . .	32
8.6.12	SCIAICTRL[x] (RW) . . . . .	32
8.7	Stereo Audio DAC . . . . .	33
<b>9</b>	<b>Operation</b>	<b>34</b>
9.1	Clocking . . . . .	34
9.2	Hardware Reset . . . . .	34
9.3	Software Reset . . . . .	34

9.4	Play/Decode . . . . .	34
9.5	Feeding PCM data . . . . .	35
9.6	SDI Tests . . . . .	35
9.6.1	Sine Test . . . . .	35
9.6.2	Pin Test . . . . .	36
9.6.3	Memory Test . . . . .	36
9.6.4	Erk Test . . . . .	36
9.6.5	SCI Test . . . . .	36
<b>10</b>	<b>VS1011b Registers</b>	<b>37</b>
10.1	Who Needs to Read This Chapter . . . . .	37
10.2	The Processor Core . . . . .	37
10.3	VS1011b Memory Map . . . . .	37
10.4	SCI Registers . . . . .	37
10.5	Serial Data Registers . . . . .	38
10.6	DAC Registers . . . . .	39
10.7	GPIO Registers . . . . .	39
10.8	Interrupt Registers . . . . .	40
10.9	System Vector Tags . . . . .	41
10.9.1	AudioInt, 0x20 . . . . .	41
10.9.2	SciInt, 0x21 . . . . .	41
10.9.3	DataInt, 0x22 . . . . .	41
10.9.4	UserCodec, 0x0 . . . . .	41
10.10	System Vector Functions . . . . .	42
10.10.1	WriteIRam(), 0x2 . . . . .	42

10.10.2 ReadIRam(), 0x4 . . . . .	42
10.10.3 DataBytes(), 0x6 . . . . .	42
10.10.4 GetDataByte(), 0x8 . . . . .	43
10.10.5 GetDataWords(), 0xa . . . . .	43
<b>11 Document Version Changes</b>	<b>44</b>
11.1 Version 1.01 for VS1011b, 2004-11-19 . . . . .	44
11.2 Version 1.00 for VS1011b, 2004-10-22 . . . . .	44
11.3 Version 0.71 for VS1011, 2004-07-20 . . . . .	44
11.4 Version 0.70 for VS1011, 2004-05-13 . . . . .	44
11.5 Version 0.62 for VS1011, 2004-03-24 . . . . .	44
11.6 Version 0.61 for VS1011, 2004-03-11 . . . . .	44
11.7 Version 0.6 for VS1011, 2004-02-13 . . . . .	44
<b>12 Contact Information</b>	<b>45</b>

## List of Figures

1	Pin Configuration, LQFP-48. . . . .	13
2	Pin Configuration, BGA-49. . . . .	13
3	Pin Configuration, SOIC-28. . . . .	14
4	Typical Connection Diagram Using LQFP-48. . . . .	17
5	BSYNC Signal - one byte transfer. . . . .	19
6	BSYNC Signal - two byte transfer. . . . .	19
7	SCI Word Read . . . . .	21
8	SCI Word Write . . . . .	21
9	SPI Timing Diagram. . . . .	22
10	Two SCI Operations. . . . .	23
11	Two SDI Bytes. . . . .	23
12	Two SDI Bytes Separated By an SCI Operation. . . . .	23
13	Data Flow of VS1011b. . . . .	25
14	User's Memory Map. . . . .	38

## 1 License

MPEG Layer-3 audio decoding technology licensed from Fraunhofer IIS and Thomson.

## 2 Disclaimer

All properties and figures are subject to change.

## 3 Definitions

**ASIC** Application Specific Integrated Circuit.

**B** Byte, 8 bits.

**b** Bit.

**IC** Integrated Circuit.

**Ki** “Kibi” =  $2^{10} = 1024$  (IEC 60027-2).

**Mi** “Mebi” =  $2^{20} = 1048576$  (IEC 60027-2).

**VS\_DSP** VLSI Solution’s DSP core.

**W** Word. In VS\_DSP, instruction words are 32-bit and data words are 16-bit wide.

## 4 Characteristics & Specifications

Unless otherwise noted: AVDD=2.7..3.6V, DVDD=2.3..3.6V, TA=-30..+85°C, XTALI=26.000MHz, Full-Scale Output Sinewave at 1.526 kHz, measurement bandwidth 20..20000 Hz, analog output load 30Ω with ground buffer, bitstream 128 kbit/s, local components as shown in Figure 4.

Note, that some analog values are in practice better than in these tables if chips are used within a limited temperature range and not too close to lower voltage limits.

### 4.1 Analog Characteristics

Parameter	Symbol	Min	Typ	Max	Unit
DAC Resolution			16		bits
Total Harmonic Distortion	THD		0.1	0.2	%
Dynamic Range (DAC unmuted, A-weighted)	IDR		88		dB
S/N Ratio (full scale signal)	SNR	70	81		dB
Interchannel Isolation (Crosstalk) <sup>1</sup>			41		dB
Interchannel Isolation (Crosstalk) <sup>2</sup>			90		dB
Interchannel Isolation (Crosstalk) <sup>3</sup>			70		dB
Interchannel Gain Mismatch		-0.5		0.5	dB
Frequency Response, 20..15000 Hz		-0.2		0.2	dB
Full Scale Output Voltage (Peak-to-peak)		1.4	1.6 <sup>4</sup>	2.1	V <sub>pp</sub>
Deviation from Linear Phase				5	°
Out of Band Energy			-90		dB
Analog Output Load Resistance	AOLR		30 <sup>5</sup>		Ω
Analog Output Load Capacitance <sup>6</sup>				10	pF

<sup>1</sup> Ground buffer, 30Ω load

<sup>2</sup> Ground buffer, no load

<sup>3</sup> AC coupled towards ground, 30Ω load

<sup>4</sup> Double voltage can be achieved with +-to-+ wiring for mono difference sound.

<sup>5</sup> AOLR may be much lower, but below *Typical* distortion performance may be compromised.

<sup>6</sup> Use small series resistor if load is capacitive.

## 4.2 Power Consumption

Following table measured with XTALI=12.288MHz, clock doubler on.

Parameter	Symbol	Min	Typ	Max	Unit
Power Supply Rejection			40		dB
Power Supply Consumption AVDD, Reset			1.4	30.0	$\mu$ A
Power Supply Consumption AVDD, no load, no signal			6.2	8.0	mA
Power Supply Consumption AVDD, o. @ 30 $\Omega$ .			6.5	40.0	mA
Power Supply Consumption DVDD, Reset			6.5	30.0	$\mu$ A
Power Supply Consumption DVDD			16.0		mA

## 4.3 DAC Interpolation Filter Characteristics

Parameter	Symbol	Min	Typ	Max	Unit
Passband (to -3dB corner)		0		0.453	Fs
Passband (Ripple Spec)		0		0.340	Fs
Passband Ripple				$\pm$ 0.2	dB
Stop Band		0.560Fs			Hz
Stop Band Rejection		85			dB
Group Delay			15/Fs		s

Fs is conversion frequency

## 4.4 Absolute Maximum Ratings

Parameter	Symbol	Min	Max	Unit
Analog Positive Supply	AVDD	-0.3	3.6	V
Digital Positive Supply	DVDD	-0.3	3.6	V
Current at Any Digital Output			$\pm$ 50	mA
Voltage at Any Digital Input		DGND-1.0	DVDD+1.0	V
Operating Temperature		-30	+85	$^{\circ}$ C
Functional Operating Temperature		-40	+95	$^{\circ}$ C
Storage Temperature		-65	+150	$^{\circ}$ C

#### 4.5 Recommended Operating Conditions

Parameter	Symbol	Min	Typ	Max	Unit
Analog and Digital Ground	AGND DGND		0.0		V
Positive Analog	AVDD	2.5	2.7	3.6	V
Positive Digital	DVDD	2.3	2.5	3.6	V
Ambient Operating Temperature		-30		+85	°C

The following values are to be used when the clock doubler is active:

Parameter	Symbol	Min	Typ	Max	Unit
Input Clock Frequency	XTALI		12.288	15	MHz
Internal Clock Frequency <sup>1</sup>	CLKI		24.576	30	MHz

<sup>1</sup> The maximum sample rate that may be played with correct speed is CLKI/512.

The following values are to be used when the clock doubler is not active:

Parameter	Symbol	Min	Typ	Max	Unit
Input Clock Frequency	XTALI		24.576	30	MHz
Internal Clock Frequency <sup>1</sup>	CLKI		24.576	30	MHz

<sup>1</sup> The maximum sample rate that may be decoded with correct speed is CLKI/512.

Note: See Application notes for what clock speeds are required to play specific bit rates and sample rates.

#### 4.6 Digital Characteristics

Parameter	Symbol	Min	Typ	Max	Unit
High-Level Input Voltage		0.7DVDD			V
Low-Level Input Voltage				0.3DVDD	V
High-Level Output Voltage at $I_O = -1.0$ mA		0.7DVDD			V
Low-Level Output Voltage at $I_O = 1.0$ mA				0.3DVDD	V
Input Leakage Current		-1.0		1.0	μA

#### 4.7 Switching Characteristics - Clocks

Parameter	Symbol	Min	Typ	Max	Unit
Master Clock Frequency <sup>1</sup>	XTALI		12.288		MHz
Master Clock Frequency <sup>2</sup>	XTALI		24.576		MHz
Master Clock Duty Cycle		40	50	60	%
Clock Output <sup>3</sup>	XTALO		XTALI		MHz

<sup>1</sup> Clock doubler active.

<sup>2</sup> Clock doubler not active.

<sup>3</sup> Do not load XTALO by connecting other devices to it.

#### 4.8 Switching Characteristics - DREQ Signal

Parameter	Symbol	Min	Typ	Max	Unit
Data Request Signal	DREQ			200	ns

#### 4.9 Switching Characteristics - SPI Interface Output

Parameter	Symbol	Min	Typ	Max	Unit
SPI Input Clock Frequency				$\frac{CLKI}{6}$	MHz
Rise time for SO				25	ns

Note: Maximum load for SO is 100 pF.

#### 4.10 Switching Characteristics - Boot Initialization

Parameter	Symbol	Min	Max	Unit
_RESET active time		2		XTALI
Power-up to software ready			2 ms + 30000 XTALI	
_RESET inactive to software ready			30000	XTALI

## 5 Packages and Pin Descriptions

### 5.1 Packages

#### 5.1.1 LQFP-48

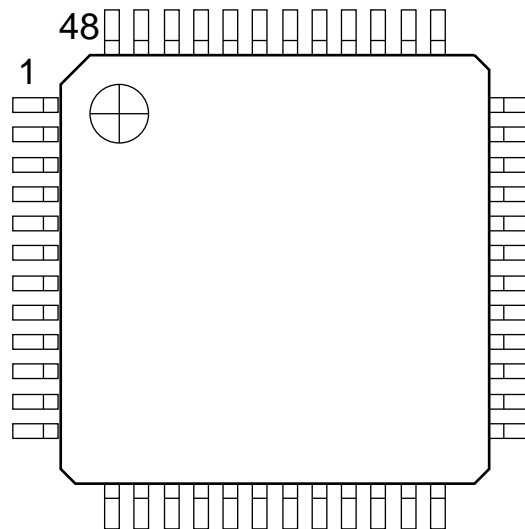

Figure 1: Pin Configuration, LQFP-48.

LQFP-48 package dimensions are at <http://www.vlsi.fi/vs1001/lqfp48.pdf>.

#### 5.1.2 BGA-49

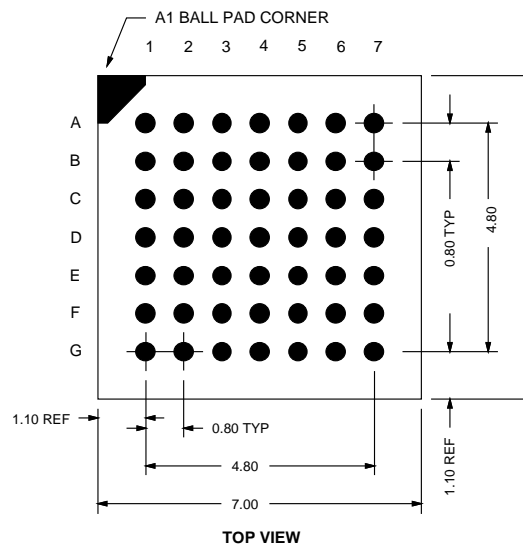

Figure 2: Pin Configuration, BGA-49.

BGA-49 package dimensions are at <http://www.vlsi.fi/vs1001/bga49.pdf>

5.1.3 SOIC-28

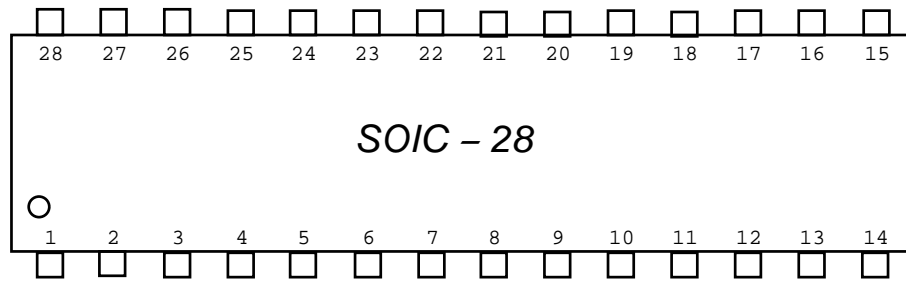

Figure 3: Pin Configuration, SOIC-28.

SOIC-28 package dimensions are at <http://www.vlsi.fi/vs1001/soic28.pdf>.

## 5.2 Pin Descriptions

### 5.2.1 LQFP-48 and BGA-49 Pin Descriptions

Pin Name	LQFP-48 Pin	BGA49 Ball	Pin Type	Function
XRESET	3	B1	DI	active low asynchronous reset
DGND0	4	D2	PWR	digital ground
DVDD0	6	D3	PWR	digital power supply
DREQ	8	E2	DO	data request, input bus
GPIO2 <sup>2</sup> / DCLK <sup>1</sup>	9	E1	DI	general purpose IO 2 / serial input data bus clock
GPIO3 <sup>2</sup> / SDATA <sup>1</sup>	10	F2	DI	general purpose IO 3 / serial data input
XDCS / BSYNC <sup>1</sup>	13	E3	DI	data chip select / byte sync, connect to DVDD if not used
DVDD1	14	F3	PWR	digital power supply
DGND1	16	F4	PWR	digital ground
XTALO	17	G3	AO	crystal output
XTALI	18	E4	AI	crystal input
DVDD2	19	G4	PWR	digital power supply
DGND2	20	F5	PWR	digital ground (in BGA-49, DGND2, 3, 4 conn. together)
DGND3	21	G5	PWR	digital ground
DGND4	22	F6	PWR	digital ground
XCS	23	G6	DI	chip select input (active low)
SCLK	28	D6	DI	clock for serial bus
SI	29	E7	DI	serial input
SO	30	D5	DO3	serial output
TEST	32	C6	DI	reserved for test, connect to DVDD
GPIO0 <sup>2</sup>	33	C7	DIO	general purpose IO 0, use 100 k $\Omega$ pull-down resistor
GPIO1 <sup>2</sup>	34	B6	DIO	general purpose IO 1
AGND0	37	C5	PWR	analog ground, low-noise reference
AVDD0	38	B5	PWR	analog power supply
RIGHT	39	A6	AO	right channel output
AGND1	40	B4	PWR	analog ground
AGND2	41	A5	PWR	analog ground
GBUF	42	C4	AO	ground buffer
AVDD1	43	A4	PWR	analog power supply
RCAP	44	B3	AIO	filtering capacitance for reference
AVDD2	45	A3	PWR	analog power supply
LEFT	46	B2	AO	left channel output
AGND3	47	A2	PWR	analog ground

<sup>1</sup> First pin function is active in New Mode, latter in Compatibility Mode.

<sup>2</sup> If not used, use 100 k $\Omega$  pull-down resistor.

Pin types:

Type	Description	Type	Description
DI	Digital input, CMOS Input Pad	AI	Analog input
DO	Digital output, CMOS Input Pad	AO	Analog output
DIO	Digital input/output	AIO	Analog input/output
DO3	Digital output, CMOS Tri-stated Output Pad	PWR	Power supply pin

In BGA-49, no-connect balls are A1, A7, B7, C1, C2, C3, D1, D4, D7, E5, E6, F1, F7, G1, G2, G7.

In LQFP-48, no-connect pins are 1, 2, 5, 7, 11, 12, 15, 24, 25, 26, 27, 31, 35, 36, 48.

### 5.2.2 SOIC-28 Pin Descriptions

Pin Name	Pin	Pin Type	Function
DREQ	1	DO	data request, input bus
GPIO2 <sup>2</sup> / DCLK <sup>1</sup>	2	DIO	serial input data bus clock
GPIO3 <sup>2</sup> / SDATA <sup>1</sup>	3	DI	serial data input
XDCS / BSYNC <sup>1</sup>	4	DI	byte synchronization signal
DVDD1	5	PWR	digital power supply
DGND1	6	PWR	digital ground
XTALO	7	CLK	crystal output
XTALI	8	CLK	crystal input
DVDD2	9	PWR	digital power supply
DGND2	10	PWR	digital ground
XCS	11	DI	chip select input (active low)
SCLK	12	DI	clock for serial bus
SI	13	DI	serial input
SO	14	DO3	serial output
TEST	15	DI	reserved for test, connect to DVDD
GPIO0 <sup>2</sup>	16	DIO	reserved for test, <i>do not connect!</i>
GPIO1 <sup>2</sup>	17	DIO	reserved for test, <i>do not connect!</i>
AGND0	18	PWR	analog ground
AVDD0	19	PWR	analog power supply
RIGHT	20	AO	right channel output
AGND2	21	PWR	analog ground
RCAP	22	AIO	filtering capacitance for reference
AVDD2	23	PWR	analog power supply
LEFT	24	AO	left channel output
AGND3	25	PWR	analog ground
XRESET	26	DI	active low asynchronous reset
DGND0	27	PWR	digital ground
DVDD0	28	PWR	digital power supply

<sup>1</sup> First pin function is active in New Mode, latter in Compatibility Mode.

<sup>2</sup> If not used, use 100 k $\Omega$  pull-down resistor.

Pin types:

Type	Description	Type	Description
DI	Digital input, CMOS Input Pad	AI	Analog input
DO	Digital output, CMOS Input Pad	AO	Analog output
DIO	Digital input/output	AIO	Analog input/output
DO3	Digital output, CMOS Tri-stated Output Pad	PWR	Power supply pin

## 6 Connection Diagram, LQFP-48

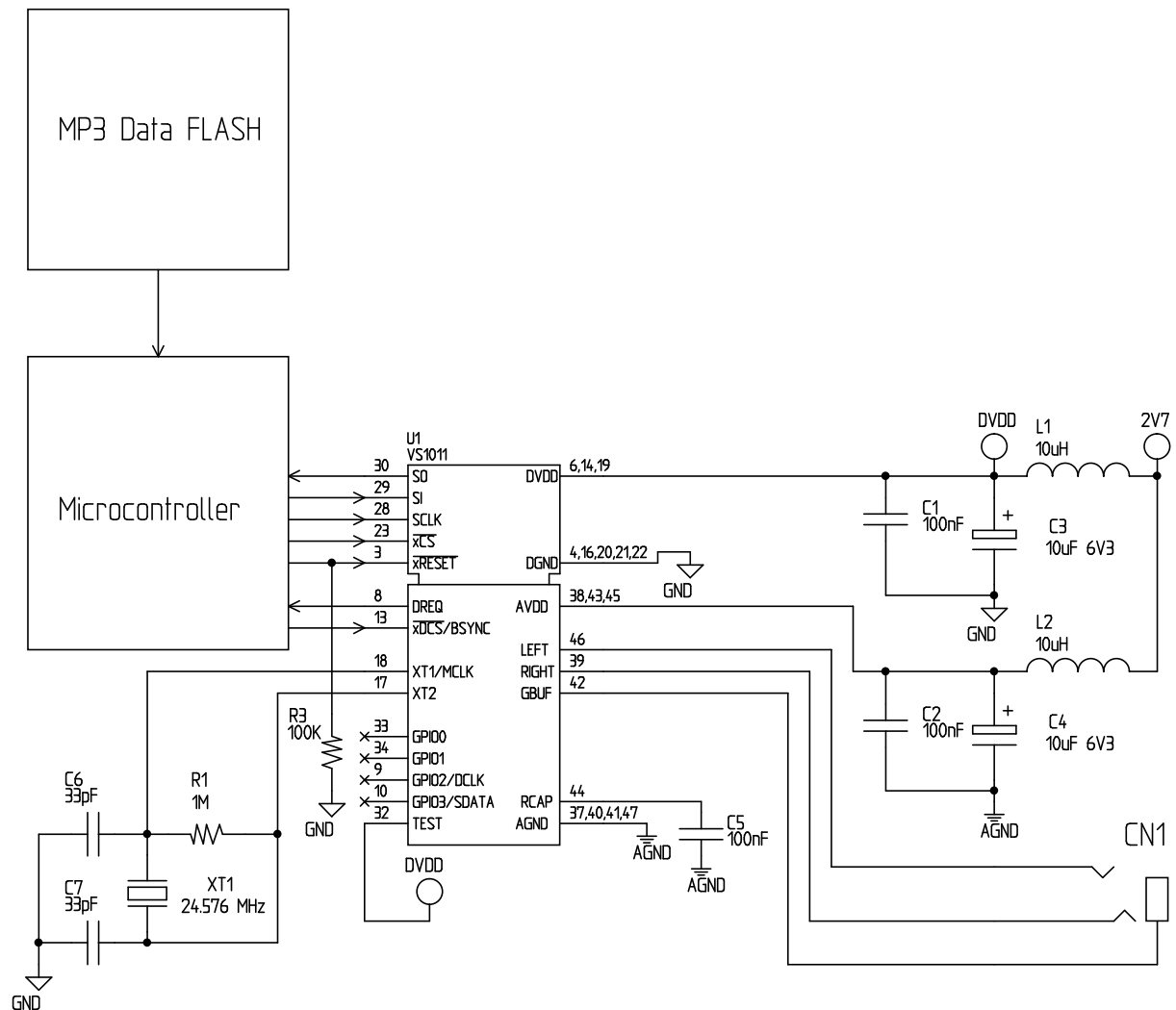

Figure 4: Typical Connection Diagram Using LQFP-48.

The ground buffer GBUF can be used for common voltage (1.25 V) for earphones. This will eliminate the need for large isolation capacitors on line outputs, and thus the audio output pins from VS1011b may be connected directly to the earphone connector.

If GBUF is not used, LEFT and RIGHT must be provided with 100  $\mu$ F capacitors.

Note: This connection assumes SM\_SDINEW is active (see Chapter 8.6.1). If also SM\_SDISHARE is used, xDCS doesn't need to be connected (see Chapter 7.2.1).

## 7 SPI Buses

### 7.1 General

The SPI Bus - that was originally used in some Motorola devices - has been used for both VS1011b's Serial Data Interface SDI (Chapters 7.3 and 8.4) and Serial Control Interface SCI (Chapters 7.4 and 8.5).

### 7.2 SPI Bus Pin Descriptions

#### 7.2.1 VS1002 Native Modes (New Mode)

These modes are active on VS1011b when SM\_SDINEW is set to 1. DCLK, SDATA and BSYNC are replaced with GPIO2, GPIO3 and XDCS, respectively.

SDI Pin	SCI Pin	Description
XDCS	XCS	Active low chip select input. A high level forces the serial interface into standby mode, ending the current operation. A high level also forces serial output (SO) to high impedance state. If SM_SDISHARE is 1, pin XDCS is not used, but the signal is generated internally by inverting XCS.
SCK		Serial clock input. The serial clock is also used internally as the master clock for the register interface. SCK can be gated or continuous. In either case, the first rising clock edge after XCS has gone low marks the first bit to be written.
SI		Serial input. If a chip select is active, SI is sampled on the rising CLK edge.
-	SO	Serial output. In reads, data is shifted out on the falling SCK edge. In writes SO is at a high impedance state.

#### 7.2.2 VS1001 Compatibility Mode

This mode is active when SM\_SDINEW is 0 (default). In this mode, DCLK, SDATA and BSYNC are active.

SDI Pin	SCI Pin	Description
-	XCS	Active low chip select input. A high level forces the serial interface into standby mode, ending the current operation. A high level also forces serial output (SO) to high impedance state. There is no chip select for SDI, which is always active.
DCLK	SCK	Serial clock input. The serial clock is also used internally as the master clock for the register interface. SCK can be gated or continuous. In either case, the first rising clock edge after XCS has gone low marks the first bit to be written.
SDATA	SI	Serial input. SI is sampled on the rising SCK edge, if XCS is low.
-	SO	Serial output. In reads, data is shifted out on the falling SCK edge. In writes SO is at a high impedance state.

### 7.3 Serial Protocol for Serial Data Interface (SDI)

#### 7.3.1 General

The serial data interface operates in slave mode so the DCLK signal must be generated by an external circuit.

Data (SDATA signal) can be clocked in at either the rising or falling edge of DCLK (Chapter 8.6).

VS1011b assumes its data input to be byte-synchronized. SDI bytes may be transmitted either MSb or LSb first, depending of contents of SCI\_MODE (Chapter 8.6).

#### 7.3.2 SDI in VS1002 Native Modes (New Mode)

In VS1002 native modes (which are available also in VS1011b), byte synchronization is achieved by XDCS (or XCS if SM\_SDISHARE is 1). The state of XDCS (or XCS) may not change while a data byte transfer is in progress. To always maintain data synchronization even if there may be glitches in the boards using VS1011b, it is recommended to turn XDCS (or XCS) every now and then, for instance once after every flash data block or a few kilobytes, just to keep sure the host and VS1011b are in sync.

For new designs, using VS1002 native modes are recommended, as they are easier to implement than BSYNC generation.

#### 7.3.3 SDI in VS1001 Compatibility Mode

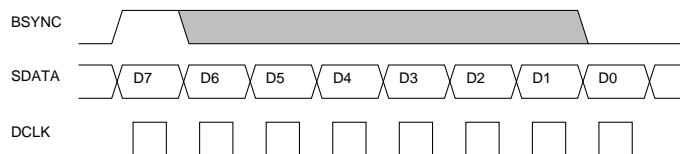

Figure 5: BSYNC Signal - one byte transfer.

When VS1011b is running in VS1001 compatibility mode, a BSYNC signal must be generated to ensure correct bit-alignment of the input bitstream. The first DCLK sampling edge (rising or falling, depending on selected polarity), during which the BSYNC is high, marks the first bit of a byte (LSB, if LSB-first order is used, MSB, if MSB-first order is used). If BSYNC is '1' when the last bit is received, the receiver stays active and next 8 bits are also received.

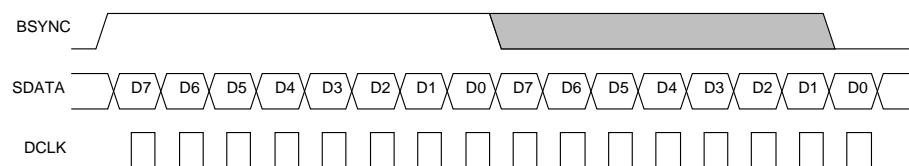

Figure 6: BSYNC Signal - two byte transfer.

Using VS1001 compatibility mode in new designs is strongly discouraged.

### 7.3.4 SDI and DREQ

The DREQ signal of the data interface is used in slave mode to signal if VS1011b's FIFO is capable of receiving more input data. If DREQ is high, VS1011b can take at least 32 bytes of data. When there is less than 32 bytes of free space, DREQ is turned low, and the sender should stop transferring new data. Because of the 32-byte safety area, the sender may send upto 32 bytes of data at a time without checking the status of DREQ, making controlling VS1011b easier for low-speed microcontrollers.

Note: DREQ may turn low or high at any time, even during a byte transmission. Thus, DREQ should only be used to decide whether to send more bytes. It should not abort a byte transmission that has already started.

## 7.4 Serial Protocol for Serial Command Interface (SCI)

### 7.4.1 General

The serial bus protocol for the Serial Command Interface SCI (Chapter 8.5) consists of an instruction byte, address byte and one 16-bit data word. Each read or write operation can read or write a single register. Data bits are read at the rising edge, so the user should update data at the falling edge. Bytes are always send MSb firrst.

The operation is specified by an 8-bit instruction opcode. The supported instructions are read and write. See table below.

Instruction		
Name	Opcode	Operation
READ	0000 0011	Read data
WRITE	0000 0010	Write data

Note: After sending an SCI command, it is not allowed to send SCI or SDI data for 5 microseconds.

7.4.2 SCI Read

VS1011b registers are read by the following sequence, as shown in Figure 7. First, XCS line is pulled SI line followed by an 8-bit word address. After the address has been read in, any further data on SI is ignored. The 16-bit data corresponding to the received address will be shifted out onto the SO line.

XCS should be driven high after data has been shifted out.

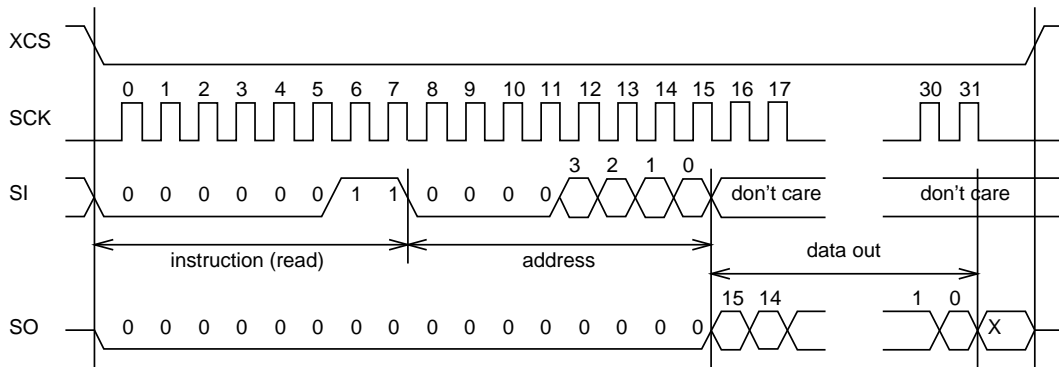

Figure 7: SCI Word Read

7.4.3 SCI Write

VS1011b registers are written to using the following sequence, as shown in Figure 8. First, XCS line is pulled low to select the device. Then the WRITE opcode (0x2) is transmitted via the SI line followed by an 8-bit word address.

After the word has been shifted in and the last clock has been sent, XCS should be pulled high to end the WRITE sequence.

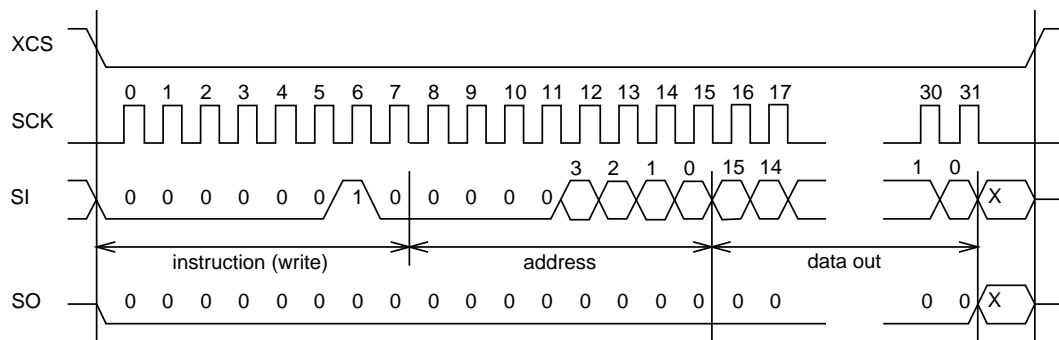

Figure 8: SCI Word Write

### 7.5 SPI Timing Diagram

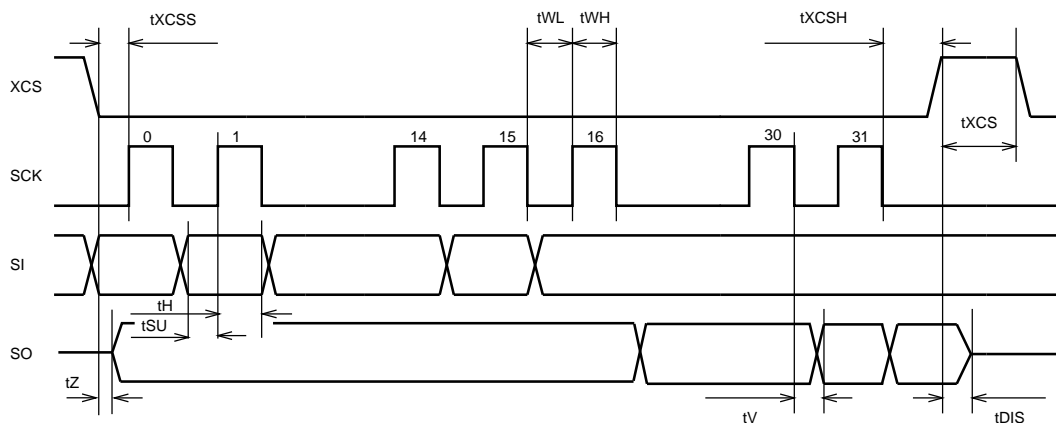

Figure 9: SPI Timing Diagram.

Symbol	Min	Max	Unit
tXCSS	5		ns
tSU	-26		ns
tH	2		XTALI cycles
tZ	0		ns
tWL	2		XTALI cycles
tWH	2		XTALI cycles
tV		2 (+ 25ns <sup>1</sup> )	XTALI cycles
tXCSH	-26		ns
tXCS	2		XTALI cycles
tDIS		10	ns

<sup>1</sup> 25ns is when pin loaded with 100pF capacitance. The time is shorter with lower capacitance.

Note: As tWL and tWH, as well as tH require at least 2 clock cycles, the maximum speed for the SPI bus that can easily be used is 1/6 of VS1011b's external clock speed XTALI. Slightly higher speed can be achieved with very careful timing tuning. For details, see Application Notes for VS10XX.

Note: Negative numbers mean that the signal can change in different order from what is shown in the diagram.

## 7.6 SPI Examples with SM\_SDINEW and SM\_SDISHARED set

### 7.6.1 Two SCI Writes

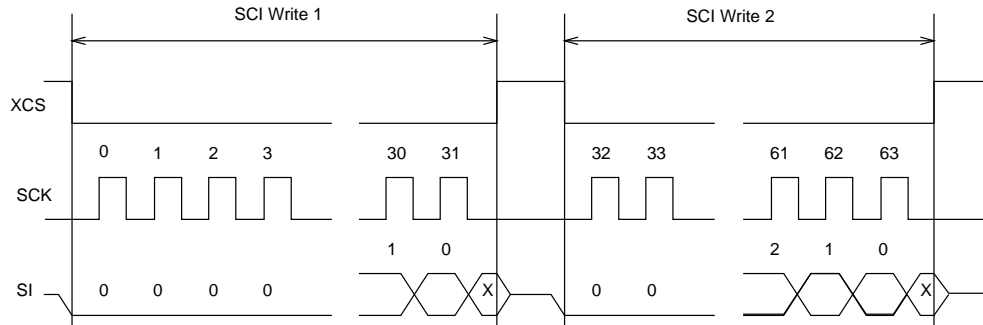

Figure 10: Two SCI Operations.

Figure 10 shows two consecutive SCI operations. Note that xCS *must* be raised to inactive state between the writes.

### 7.6.2 Two SDI Bytes

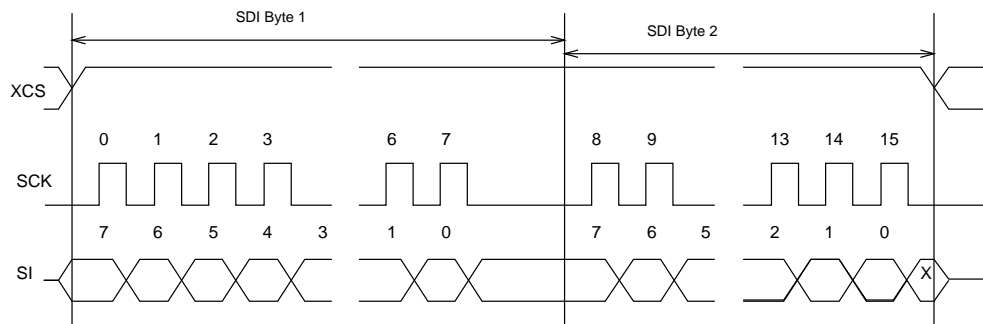

Figure 11: Two SDI Bytes.

SDI data is synchronized with a raising edge of xCS as shown in Figure 11. However, every byte doesn't need separate synchronization.

### 7.6.3 SCI Operation in Middle of Two SDI Bytes

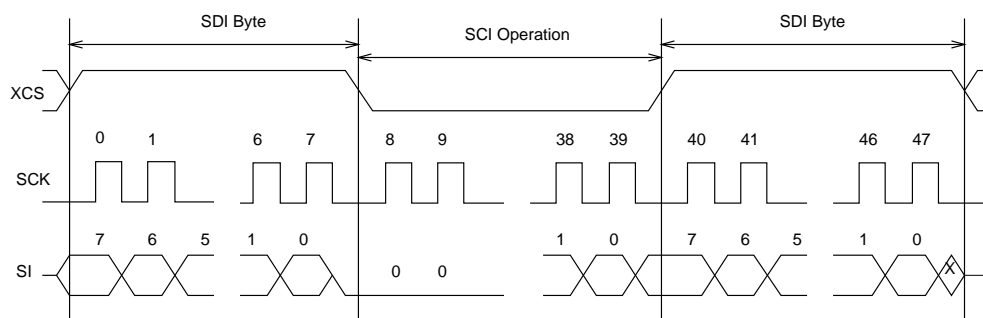

Figure 12: Two SDI Bytes Separated By an SCI Operation.

Figure 12 shows how an SCI operation is embedded in between SDI operations. The changes in xCS are used to synchronize both SDI and SCI.

## 8 Functional Description

### 8.1 Main Features

VS1011b is based on a proprietary digital signal processor, VS\_DSP. It contains all the code and data memory needed for MPEG and WAV PCM audio decoding, together with serial interfaces, a multirate stereo audio DAC and analog output amplifiers and filters.

VS1011b can play all MPEG 1 and 2 layer III files, with all sample rates and bitrates, including variable bitrate (VBR).

### 8.2 Supported Audio Codecs

Conventions	
Mark	Description
+	Format is supported
-	Format exists but is not supported
	Format doesn't exist

#### 8.2.1 Supported MP3 (MPEG layer 3) Formats

MPEG 1.0<sup>1</sup>:

Samplerate / Hz	Bitrate / kbit/s													
	32	40	48	56	64	80	96	112	128	160	192	224	256	320
48000	+	+	+	+	+	+	+	+	+	+	+	+	+	+
44100	+	+	+	+	+	+	+	+	+	+	+	+	+	+
32000	+	+	+	+	+	+	+	+	+	+	+	+	+	+

MPEG 2.0<sup>1</sup>:

Samplerate / Hz	Bitrate / kbit/s													
	8	16	24	32	40	48	56	64	80	96	112	128	144	160
24000	+	+	+	+	+	+	+	+	+	+	+	+	+	+
22050	+	+	+	+	+	+	+	+	+	+	+	+	+	+
16000	+	+	+	+	+	+	+	+	+	+	+	+	+	+

MPEG 2.5<sup>1 2</sup>:

Samplerate / Hz	Bitrate / kbit/s													
	8	16	24	32	40	48	56	64	80	96	112	128	144	160
12000	+	+	+	+	+	+	+	+	+	+	+	+	+	+
11025	+	+	+	+	+	+	+	+	+	+	+	+	+	+
8000	+	+	+	+	+	+	+	+	+	+	+	+	+	+

<sup>1</sup> Also all variable bitrate (VBR) formats are supported.

<sup>2</sup> Incompatibilities may occur because MPEG 2.5 is not a standard format.

<sup>3</sup> Nominal CLKI=24.576 MHz may be too little for glitchless playback.

### 8.2.2 Supported RIFF WAV Formats

The most common RIFF WAV subformats are supported.

Format	Name	Supported	Comments
0x01	PCM	+	16 and 8 bits, any sample rate $\leq$ 48kHz
0x02	ADPCM	-	
0x03	IEEE_FLOAT	-	
0x06	ALAW	-	
0x07	MULAW	-	
0x10	OKI_ADPCM	-	
0x11	IMA_ADPCM	-	
0x15	DIGISTD	-	
0x16	DIGIFIX	-	
0x30	DOLBY_AC2	-	
0x31	GSM610	-	
0x3b	ROCKWELL_ADPCM	-	
0x3c	ROCKWELL_DIGITALK	-	
0x40	G721_ADPCM	-	
0x41	G728_CELP	-	
0x50	MPEG	-	
0x55	MPEGLAYER3	+	For supported MP3 modes, see Chapter 8.2.1
0x64	G726_ADPCM	-	
0x65	G722_ADPCM	-	

### 8.3 Data Flow of VS1011b

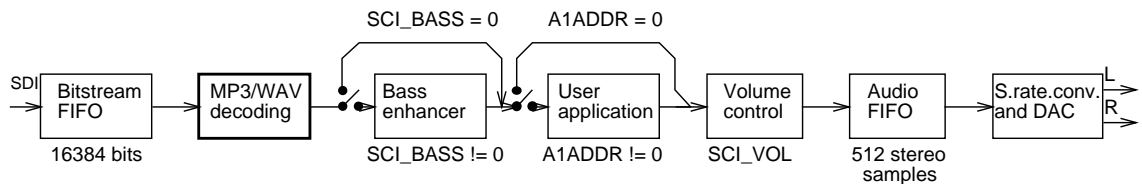

Figure 13: Data Flow of VS1011b.

First, depending on the audio data, MP3 or PCM WAV data is received and decoded from the SDI bus.

After decoding, data may be sent to the Bass Enhancer depending on SCI.BASS.

Then, if SCI.AIADDR is non-zero, application code is executed from the address pointed to by that register. For more details, see Application Notes for VS10XX.

After the optional user application, the signal is fed to the volume control unit, which also copies the data to the Audio FIFO.

The Audio FIFO holds the data, which is read by the Audio interrupt (Chapter 10.9.1) and fed to the sample rate converter and DACs. The size of the audio FIFO is 512 stereo ( $2 \times 16$ -bit) samples.

The sample rate converter converts all different sample rates to CLKI/512 and feeds the data to the DAC, which in order creates a stereo in-phase analog signal. This signal is then forwarded to the earphone amplifier.

## 8.4 Serial Data Interface (SDI)

The serial data interface is meant for transferring compressed MP3 audio data as well as WAV PCM data.

Also several different tests may be activated through SDI as described in Chapter 9.

## 8.5 Serial Control Interface (SCI)

The serial control interface is compatible with the SPI bus specification. Data transfers are always 16 bits. VS1011b is controlled by writing and reading the registers of the interface.

The main controls of the control interface are:

- control of the operation mode
- uploading user programs
- access to header data
- status information
- feeding input data

## 8.6 SCI Registers

SCI registers, prefix SCI_, offset 0xC000				
Reg	Type	Reset	Abbrev[bits]	Description
0x0	rw	0	MODE	Mode control.
0x1	rw	0x1C <sup>1</sup>	STATUS	Status of VS1011b.
0x2	rw	0	BASS	Built-in bass enhancer.
0x3	rw	0	CLOCKF	Clock freq + doubler.
0x4	r	0	DECODE_TIME	Decode time in seconds.
0x5	rw	0	AUDATA	Misc. audio data.
0x6	rw	0	WRAM	RAM write.
0x7	rw	0	WRAMADDR	Base address for RAM write.
0x8	r	0	HDATA0	Stream header data 0.
0x9	r	0	HDATA1	Stream header data 1.
0xA	rw	0	AIADDR	Start address of application.
0xB	rw	0	VOL	Volume control.
0xC	rw	0	AICTRL0	Application control register 0.
0xD	rw	0	AICTRL1	Application control register 1.
0xE	rw	0	AICTRL2	Application control register 2.
0xF	rw	0	AICTRL3	Application control register 3.

<sup>1</sup> Firmware changes the value of this register immediately to 0x18, and in less than 100 ms to 0x10.

### 8.6.1 SCI\_MODE (RW)

SCI\_MODE is used to control operation of VS1011b.

Bit	Name	Function	Value	Description
0	SM_DIFF	Differential	0	normal in-phase audio
			1	left channel inverted
1	SM_SETTOZERO1	Set to zero	0	right
			1	wrong
2	SM_RESET	Soft reset	0	no reset
			1	reset
3	SM_OUTOFWAV	Jump out of WAV decoding	0	no
			1	yes
4	SM_SETTOZERO2	set to zero	0	right
			1	wrong
5	SM_TESTS	Allow SDI tests	0	not allowed
			1	allowed
6	SM_STREAM	Stream mode	0	no
			1	yes
7	SM_SETTOZERO3	set to zero	0	right
			1	wrong
8	SM_DACT	DCLK active edge	0	rising
			1	falling
9	SM_SDIORD	SDI bit order	0	MSb first
			1	MSb last
10	SM_SDISHARE	Share SPI chip select	0	no
			1	yes
11	SM_SDINEW	VS1002 native SPI modes	0	no
			1	yes
12	SM_SETTOZERO4	set to zero	0	right
			1	wrong
13	SM_SETTOZERO5	set to zero	0	right
			1	wrong

When SM\_DIFF is set, the player inverts the left channel output. For a stereo input this creates a virtual surround, and for a mono input this effectively creates a differential left/right signal.

By setting SM\_RESET to 1, the player is software reset. This bit clears automatically.

When the user decoding a WAV file wants to get out of the file without playing it to the end, set SM\_OUTOFWAV, and send zeros to VS1002c until SM\_OUTOFWAV is again zero. If the user doesn't want to check SM\_OUTOFWAV, send 128 zeros.

If SM\_TESTS is set, SDI tests are allowed. For more details on SDI tests, look at Chapter 9.6.

SM\_STREAM activates VS1011b's stream mode. In this mode, data should be sent with as even intervals as possible (and preferable with data blocks of less than 512 bytes), and VS1011b makes every attempt to keep its input buffer half full by changing its playback speed up to 5%. For best quality sound, the

average speed error should be within 0.5%, the bitrate should not exceed 160 kbit/s and VBR should not be used. For details, see Application Notes for VS10XX.

SM\_DACT defines the active edge of data clock for SDI. If clear data is read at the rising edge, and if set data is read at the falling edge.

When SM\_SDIORD is clear, bytes on SDI are sent as a default MSb first. By setting SM\_SDIORD, the user may reverse the bit order for SDI, i.e. bit 0 is received first and bit 7 last. Bytes are, however, still sent in the default order. This register bit has no effect on the SCI bus.

Setting SM\_SDISHARE makes SCI and SDI share the same chip select, as explained in Chapter 7.2, if also SM\_SDINEW is set.

Setting SM\_SDINEW will activate VS1002 native serial modes as described in Chapters 7.2.1 and 7.3.2.

### 8.6.2 SCLSTATUS (RW)

SCLSTATUS contains information on the current status of VS1011b and lets the user shutdown the chip without audio glitches.

Name	Bits	Description
SS_VER	6..4	Version
SS_APDOWN2	3	Analog driver powerdown
SS_APDOWN1	2	Analog internal powerdown
SS_AVOL	1..0	Analog volume control

SS\_VER is 0 for VS1001, 1 for VS1011, 2 for VS1002 and 3 for vs1003.

SS\_APDOWN2 controls analog driver powerdown. Normally this bit is controlled by the system firmware. However, if the user wants to powerdown VS1011b with a minimum power-off transient, turn this bit to 1, then wait for at least a few milliseconds before activating reset. For more details, see Application Notes for VS10XX.

SS\_APDOWN1 controls internal analog powerdown. This bit is meant to be used by the system firmware only.

SS\_AVOL is the analog volume control: 0 = -0 dB, 1 = -6 dB, 3 = -12 dB. This register is meant to be used automatically by the system firmware only.

### 8.6.3 SCLBASS (RW)

Name	Bits	Description
SB_AMPLITUDE	7..4	Enhancement in 1 dB steps (0..15)
SB_FREQLIMIT	3..0	Lower limit frequency in 10 Hz steps (2..15)

The Bass Enhancer VSBE is a powerful bass boosting DSP algorithm, which tries to take the most out of the users earphones without causing clipping.

VSBE is activated when SB\_AMPLITUDE is set to non-zero. SB\_AMPLITUDE should be set to the user's preferences, and SB\_FREQLIMIT to roughly 1.5 times the lowest frequency the user's audio system can reproduce.

Note: Because VSBE tries to avoid clipping, it gives the best bass boost with dynamical music material, or when the playback volume is not set to maximum.

#### 8.6.4 SCICLOCKF (RW)

SCICLOCKF is used to tell if the input clock XTALI is running at something else than 24.576 MHz. XTALI is set in 2 kHz steps. Thus, the formula for calculating the correct value for this register is  $\frac{XTALI}{2000}$  (XTALI is in Hz). Values may be between 0..32767, although hardware limits the highest allowed speed. Also, with speeds lower than 24.576 MHz all sample rates and bitstream widths are no longer available.

Setting the MSB of SCICLOCKF to 1 activates internal clock-doubling. A clock of upto 15 MHz may be doubled depending on the voltage provided to the chip.

Note: SCICLOCKF must be set before beginning decoding audio data; otherwise the sample rate will not be set correctly.

Note: SCICLOCKF needs to be rewritten after each software reset. This is different from how VS1002 operates.

Example 1: For a 26 MHz clock the value would be  $\frac{26000000}{2000} = 13000$ .

Example 2: For a 13 MHz external clock and using internal clock-doubling for a 26 MHz internal frequency, the value would be  $0x8000 + \frac{13000000}{2000} = 39268$ .

Example 3: For a 24.576 MHz clock the value would be either  $\frac{24576000}{2000} = 12288$ , or just the default value 0. For this clock frequency, SCICLOCKF doesn't need to be set.

#### 8.6.5 SCI\_DECODE\_TIME (RW)

When decoding correct data, current decoded time is shown in this register in full seconds.

The user may change the value of this register. However, in that case the new value should be written twice.

SCI\_DECODE\_TIME is reset at every software reset.

### 8.6.6 SCIAUDATA (RW)

When decoding correct data, the current sample rate and number of channels can be found in bits 15..1 and 0 of SCIAUDATA, respectively. Bits 15..1 contain the sample rate divided by two, and bit 0 is 0 for mono data and 1 for stereo. Writing to this register will change the sample rate on the run to the number given.

Example: 44100 Hz stereo data reads as 0xAC45 (44101).

### 8.6.7 SCI\_WRAM (RW)

SCI\_WRAM is used to upload application programs and data to instruction and data RAMs. The start address must be initialized by writing to SCI\_WRAMADDR prior to the first call of SCI\_WRAM. As 16 bits of data can be transferred with one SCI\_WRAM write, and the instruction word is 32 bits long, two consecutive writes are needed for each instruction word. The byte order is big-endian (i.e. MSBs first). After each full-word write, the internal pointer is autoincremented.

<b>SM_WRAMADDR Start...End</b>	<b>Dest. addr. Start...End</b>	<b>Bits/ Word</b>	<b>Description</b>
0x1380...0x13FF	0x1380...0x13FF	16	X data RAM
0x4780...0x47FF	0x0780...0x07FF	16	Y data RAM
0x8030...0x84FF	0x0030...0x04FF	32	Instruction RAM

### 8.6.8 SCI\_WRAMADDR (RW)

SCI\_WRAMADDR is used to set the program address for following SCI\_WRAM writes.

8.6.9 SCI\_HDAT0 and SCI\_HDAT1 (R)

Bit	Function	Value	Explanation
HDAT1[15:5]	syncword	2047	stream valid
HDAT1[4:3]	ID	3	ISO 11172-3 1.0
		2	MPG 2.0 (1/2-rate)
		1	MPG 2.5 (1/4-rate)
		0	MPG 2.5 (1/4-rate)
HDAT1[2:1]	layer	3	I
		2	II
		1	III
		0	reserved
HDAT1[0]	protect bit	1	No CRC
		0	CRC protected
HDAT0[15:12]	bitrate		ISO 11172-3
HDAT0[11:10]	sample rate	3	reserved
		2	32/16/8 kHz
		1	48/24/12 kHz
		0	44/22/11 kHz
HDAT0[9]	pad bit	1	additional slot
		0	normal frame
HDAT0[8]	private bit		not defined
HDAT0[7:6]	mode	3	mono
		2	dual channel
		1	joint stereo
		0	stereo
HDAT0[5:4]	extension		ISO 11172-3
HDAT0[3]	copyright	1	copyrighted
		0	free
HDAT0[2]	original	1	original
		0	copy
HDAT0[1:0]	emphasis	3	CCITT J.17
		2	reserved
		1	50/15 microsec
		0	none

When read, SCI\_HDAT0 and SCI\_HDAT1 contain header information that is extracted from MPEG stream being currently being decoded. Right after resetting VS1011b, 0 is automatically written to both registers, indicating no data has been found yet.

The “sample rate” field in SCI\_HDAT0 is interpreted according to the following table:

“sample rate”	ID=3 / Hz	ID=2 / Hz	ID=0,1 / Hz
3	-	-	-
2	32000	16000	8000
1	48000	24000	12000
0	44100	22050	11025

The “bitrate” field in HDAT0 is read according to the following table:

“bitrate”	ID=3 / kbit/s	ID=0,1,2 / kbit/s
15	forbidden	forbidden
14	320	160
13	256	144
12	224	128
11	192	112
10	160	96
9	128	80
8	112	64
7	96	56
6	80	48
5	64	40
4	56	32
3	48	24
2	40	16
1	32	8
0	-	-

When decoding a WAV file, SPI\_HDAT0 and SPI\_HDAT1 read as 0x7761, and 0x7665, respectively.

#### 8.6.10 SCIAIADDR (RW)

SCIAIADDR indicates the start address of the application code written earlier with SCI\_WRAMADDR and SCI\_WRAM registers. If no application code is used, this register should not be initialized, or it should be initialized to zero. For more details, see Application Notes for VS10XX.

#### 8.6.11 SCI\_VOL (RW)

SCI\_VOL is a volume control for the player hardware. For each channel, a value in the range of 0..191 or 255 may be defined to set its attenuation from the maximum volume level (in 0.5 dB steps). The left channel value is then multiplied by 256 and the values are added. Thus, maximum volume is 0 and total silence if 0xFFFF. Example: for a volume of -2.0 dB for the left channel and -3.5 dB for the right channel:  $(4 * 256) + 7 = 0x407$ . Note, that at startup volume is set to full volume. Resetting the software does not reset the volume setting.

Note: Setting the volume to total silence (255 for both left and right channels) will turn analog power off.

#### 8.6.12 SCIAICTRL[x] (RW)

SCIAICTRL[x] registers (  $x=[0 .. 3]$  ) can be used to access the user's application program.

## 8.7 Stereo Audio DAC

Decoded digital data is transformed into analog format by an 18/20-bit oversampling multi-bit sigma-delta D/A converter. The oversampled output is low-pass filtered by an on-chip analog filter. The output rate of the D/A converter is always 1/4 of the clock rate, or 128 times the highest usable sample rate. For instance for a 24.576 MHz clock, the D/A converter operates at 128x48 kHz, which is 6.144 MHz. If the input sample rate is other than 48 kHz, it is internally converted to 48 kHz by the DAC. This removes the need for complex PLL-based clocking schemes and allows almost unlimited sample rate accuracy with one fixed master clock frequency.

If the input of the decoder is invalid or it is not received fast enough, analog outputs are automatically muted.

## 9 Operation

### 9.1 Clocking

VS1011b operates on a single, nominally 24.576 MHz fundamental frequency master clock. This clock can be generated by external circuitry (connected to pin XTALI) or by the internal clock crystal interface (pins XTALI and XTALO). This clock is sufficient to support a high quality audio output for almost all standard sample rates and bit-rates (see Application Notes for VS10XX).

### 9.2 Hardware Reset

When the XRESET -signal is driven low, VS1011b is reset and all the control registers and internal states are set to the initial values. XRESET-signal is asynchronous to any external clock. The reset mode doubles as a full-powerdown mode, where both digital and analog parts of VS1011b are in minimum power consumption stage, and where clocks are stopped. Also XTALO and XTALI are grounded.

After a hardware reset (or at power-up), the user should set such basic software registers as SCL\_VOL for volume (and SCL\_CLOCKF if the input clock is anything else than 24.576 MHz) before starting decoding.

### 9.3 Software Reset

In some cases the decoder software has to be reset. This is done by activating bit 2 in SCL\_MODE register (Chapter 8.6.1). Then wait for at least 2  $\mu$ s, then look at DREQ. DREQ will stay down for at least 6000 clock cycles, which means an approximate 250  $\mu$ s delay if VS1011b is run at 24.576 MHz. After DREQ is up, you may continue playback as usual.

If you want to make sure VS1011b doesn't cut the ending of low-bitrate data streams and you want to do a software reset, it is recommended to feed 2048 zeros to the SDI bus after the file and before the reset.

### 9.4 Play/Decode

This is the normal operation mode of VS1011b. SDI data is decoded. Decoded samples are converted to analog domain by the internal DAC. If there are bad problems in the decoding process, the error flags of SCL\_HDAT0 and SCL\_HDAT1 are set to 0 and analog outputs are muted.

When there is no input for decoding, VS1011b goes into idle mode (lower power consumption than during decoding) and actively monitors the serial data input for valid data.

## 9.5 Feeding PCM data

VS1011b can be used as a PCM decoder by sending to it a WAV file header. If the length sent in the WAV file is 0 or 0xFFFFFFFF, VS1011b will stay in PCM mode indefinitely. 8-bit linear and 16-bit linear audio is supported in mono or stereo.

## 9.6 SDI Tests

There are several test modes in VS1011b, which allow the user to perform memory tests, SCI bus tests, and several different sine wave tests.

All tests are started in a similar way: VS1011b is hardware reset, SM\_TESTS is set, and then a test command is sent to the SDI bus. Each test is started by sending a 4-byte special command sequence, followed by 4 zeros. The sequences are described below.

### 9.6.1 Sine Test

Sine test is initialized with the 8-byte sequence 0x53 0xEF 0x6E *n* 0 0 0 0, where *n* defines the sine test to use. *n* is defined as follows:

<i>n</i> bits		
Name	Bits	Description
$F_sIdx$	7:5	Sample rate index
<i>S</i>	4:0	Sine skip speed

$F_sIdx$	$F_s$
0	44100 Hz
1	48000 Hz
2	32000 Hz
3	22050 Hz
4	24000 Hz
5	16000 Hz
6	11025 Hz
7	12000 Hz

The frequency of the sine to be output can now be calculated from  $F = F_s \times \frac{S}{128}$ .

Example: Sine test is activated with value 126, which is 0b01111110. Breaking *n* to its components,  $F_sIdx = 0b011 = 1$  and thus  $F_s = 22050Hz$ .  $S = 0b11110 = 30$ , and thus the final sine frequency  $F = 22050Hz \times \frac{30}{128} \approx 5168Hz$ .

To exit the sine test, send the sequence 0x45 0x78 0x69 0x74 0 0 0 0.

Note: Sine test signals go through the digital volume control, so it is possible to test channels separately.

### 9.6.2 Pin Test

Pin test is activated with the 8-byte sequence 0x50 0xED 0x6E 0x54 0 0 0 0. This test is meant for chip production testing only.

### 9.6.3 Memory Test

Memory test mode is initialized with the 8-byte sequence 0x4D 0xEA 0x6D 0x54 0 0 0 0. After this sequence, wait for 200000 clock cycles. The result can be read from the SCI register SCI.HDAT0, and 'one' bits are interpreted as follows:

Bit(s)	Meaning
15	Test finished
14..7	Unused
6	Mux test succeeded
5	Good I RAM
4	Good Y RAM
3	Good X RAM
2	Good I ROM
1	Good Y ROM
0	Good X ROM

Memory tests overwrite the current contents of the RAM memories.

### 9.6.4 Erk Test

Erk test is activated with the 8-byte sequence 0xCB 0x72 0x6B 0x54 0 0 0 0. This test is meant for chip production testing only.

### 9.6.5 SCI Test

Sci test is initialized with the 8-byte sequence 0x53 0x70 0xEE  $n$  0 0 0 0, where  $n - 48$  is the register number to test. The content of the given register is read and copied to SCI.HDAT0. If the register to be tested is HDAT0, the result is copied to SCI.HDAT1.

Example: if  $n$  is 48, contents of SCI register 0 (SCI.MODE) is copied to SCI.HDAT0.

## 10 VS1011b Registers

### 10.1 Who Needs to Read This Chapter

User software is required when a user wishes to add some own functionality like DSP effects or tone controls to VS1011b.

However, most users of VS1011b don't need to worry about writing their own code, or about this chapter, including those who only download software plug-ins from VLSI Solution's Web site.

### 10.2 The Processor Core

VS\_DSP is a 16/32-bit DSP processor core that also had extensive all-purpose processor features. VLSI Solution's free VSKIT Software Package contains all the tools and documentation needed to write, simulate and debug Assembly Language or Extended ANSI C programs for the VS\_DSP processor core. VLSI Solution also offers a full Integrated Development Environment VSIDE for full debug capabilities.

### 10.3 VS1011b Memory Map

VS1011b's Memory Map is shown in Figure 14.

### 10.4 SCI Registers

SCI registers described in Chapter 8.6 can be found here between 0xC000..0xC00F. In addition to these registers, there is one in address 0xC010, called SPI\_CHANGE.

SPI registers, prefix SPI_				
Reg	Type	Reset	Abbrev[bits]	Description
0xC010	r	0	CHANGE[5:0]	Last SCI access address.

SPI_CHANGE bits		
Name	Bits	Description
SPI.CH.WRITE	4	1 if last access was a write cycle.
SPI.CH.ADDR	3:0	SPI address of last access.

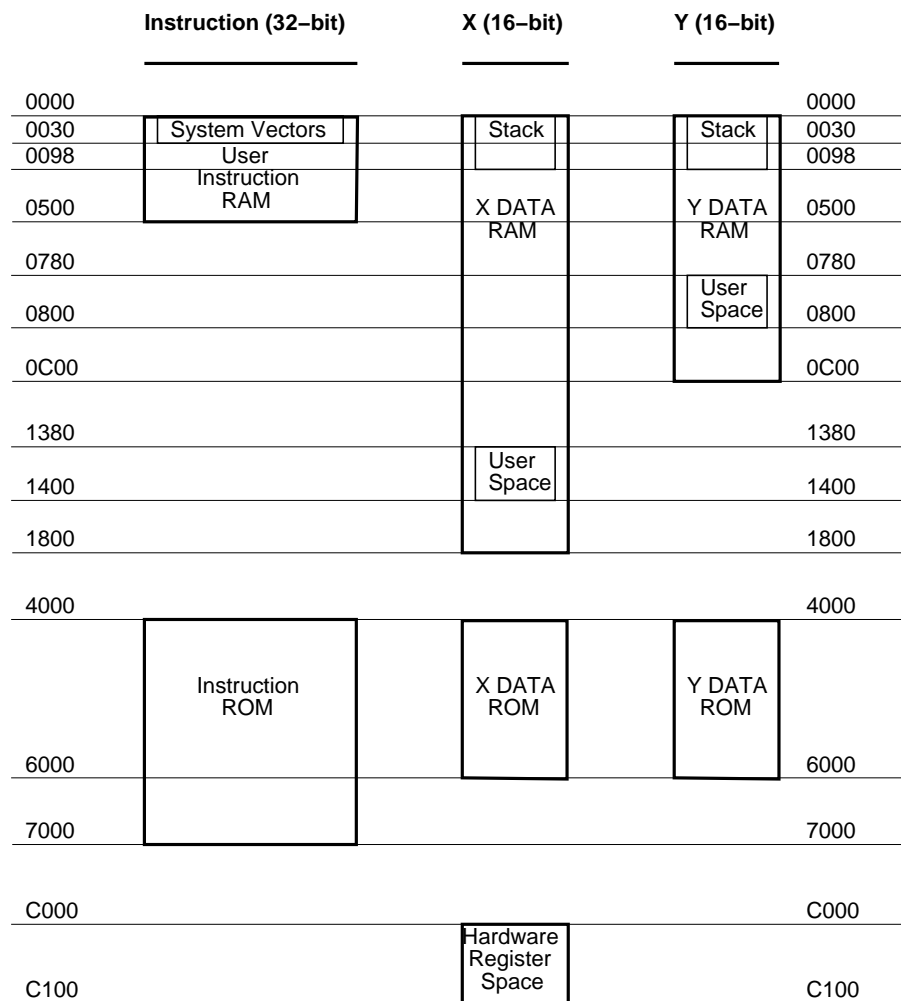

Figure 14: User's Memory Map.

## 10.5 Serial Data Registers

SDI registers, prefix SER_				
Reg	Type	Reset	Abbrev[bits]	Description
0xC011	r	0	DATA	Last received 2 bytes, big-endian.
0xC012	w	0	DREQ[0]	DREQ pin control.

## 10.6 DAC Registers

DAC registers, prefix DAC_				
Reg	Type	Reset	Abbrev[bits]	Description
0xC013	rw	0	FCTLL	DAC frequency control, 16 LSbs.
0xC014	rw	0	FCTLH[4:0]	Clock doubler + DAC frequency control MSbs.
0xC015	rw	0	LEFT	DAC left channel PCM value.
0xC016	rw	0	RIGHT	DAC right channel PCM value.

Every fourth clock cycle, an internal 26-bit counter is added to by  $DAC\_FCTLH[3:0] \times 65536 + DAC\_FCTLL$ . Whenever this counter overflows, values from `DAC_LEFT` and `DAC_RIGHT` are read and a DAC interrupt is generated.

If `DAC_FCTL[4]` is 1, the internal clock doubler is activated.

## 10.7 GPIO Registers

GPIO registers, prefix GPIO_				
Reg	Type	Reset	Abbrev[bits]	Description
0xC017	rw	0	DDR[3:0]	Direction.
0xC018	r	0	IDATA[3:0]	Values read from the pins.
0xC019	rw	0	ODATA[3:0]	Values set to the pins.

`GPIO_DIR` is used to set the direction of the GPIO pins. 1 means output. `GPIO_ODATA` remembers its values even if a `GPIO_DIR` bit is set to input.

GPIO registers don't generate interrupts.

Note: Bits 2 and 3 of `GPIO_DDR` and `GPIO_ODATA` are switched in some pre-production VS1011's dated 2003. Thus, for example, writing 8 to both registers in such a chip will set pin `GPIO2` to 1 instead of `GPIO3`.

## 10.8 Interrupt Registers

Interrupt registers, prefix INT_				
Reg	Type	Reset	Abbrev[bits]	Description
0xC01a	rw	0	ENABLE[2:0]	Interrupt enable.
0xC01b	w	0	GLOB_DIS[-]	Write to add to interrupt counter.
0xC01c	w	0	GLOB_ENA[-]	Write to subtract from interrupt counter.
0xC01d	rw	0	COUNTER[4:0]	Interrupt counter.

INT\_ENABLE controls the interrupts. The control bits are as follows:

INT_ENABLE bits		
Name	Bits	Description
INT_EN_SDI	2	Enable Data interrupt.
INT_EN_SCI	1	Enable SCI interrupt.
INT_EN_DAC	0	Enable DAC interrupt.

Note: It may take upto 6 clock cycles before changing INT\_ENABLE has any effect.

Writing any value to INT\_GLOB\_DIS adds one to the interrupt counter INT\_COUNTER and effectively disables all interrupts. It may take upto 6 clock cycles before writing to this register has any effect.

Writing any value to INT\_GLOB\_ENA subtracts one from the interrupt counter (unless INT\_COUNTER already was 0). If the interrupt counter becomes zero, interrupts selected with INT\_ENABLE are re-stored. An interrupt routine should always write to this register as the last thing it does, because interrupts automatically add one to the interrupt counter, but subtracting it back to its initial value is the responsibility of the user. It may take upto 6 clock cycles before writing this register has any effect.

By reading INT\_COUNTER the user may check if the interrupt counter is correct or not. If the register is not 0, interrupts are disabled.

## 10.9 System Vector Tags

The System Vector Tags are tags that may be replaced by the user to take control over several decoder functions.

### 10.9.1 AudioInt, 0x20

Normally contains the following VS\_DSP assembly code:

```
jmp i DAC_INT_ADDRESS, (i6)+1
```

The user may, at will, replace the instruction with a *jmp i* command to gain control over the audio interrupt.

### 10.9.2 SciInt, 0x21

Normally contains the following VS\_DSP assembly code:

```
jmp i SCI_INT_ADDRESS, (i6)+1
```

The user may, at will, replace the instruction with a *jmp i* command to gain control over the SCI interrupt.

### 10.9.3 DataInt, 0x22

Normally contains the following VS\_DSP assembly code:

```
jmp i SDI_INT_ADDRESS, (i6)+1
```

The user may, at will, replace the instruction with a *jmp i* command to gain control over the SDI interrupt.

### 10.9.4 UserCodec, 0x0

Normally contains the following VS\_DSP assembly code:

```
jr  
nop
```

If the user wants to take control away from the standard decoder, the first instruction should be replaced with an appropriate *j* command to user's own code.

Unless the user is feeding MP3 data at the same time, the system activates the user program in less than 1 ms. After this, the user should steal interrupt vectors from the system, and insert user programs.

## 10.10 System Vector Functions

The System Vector Functions are pointers to some functions that the user may call to help implementing his own applications.

### 10.10.1 WriteIRam(), 0x2

VS\_DSP C prototype:

```
void WriteIRam(register __i0 u_int16 *addr, register __a1 u_int16 msW, register __a0 u_int16 lsW);
```

This is the only supported way to write to the User Instruction RAM. This is because Instruction RAM cannot be written when program control is in RAM. Thus, the actual implementation of this function is in ROM, and here is simply a tag to that routine.

### 10.10.2 ReadIRam(), 0x4

VS\_DSP C prototype:

```
u_int32 ReadIRam(register __i0 u_int16 *addr);
```

This is the only supported way to read from the User Instruction RAM. This is because Instruction RAM cannot be read when program control is in RAM. Thus, the actual implementation of this function is in ROM, and here is simply a tag to that routine.

A1 contains the MSBs and a0 the LSBs of the result.

### 10.10.3 DataBytes(), 0x6

VS\_DSP C prototype:

```
u_int16 DataBytes(void);
```

If the user has taken over the normal operation of the system by switching the pointer in UserCodec to point to his own code, he may read data from the Data Interface through this and the following two functions.

This function returns the number of data bytes that can be read.

#### 10.10.4 GetDataByte(), 0x8

VS\_DSP C prototype:

```
u_int16 GetDataByte(void);
```

Reads and returns one data byte from the Data Interface. This function will wait until there is enough data in the input buffer.

#### 10.10.5 GetDataWords(), 0xa

VS\_DSP C prototype:

```
void GetDataWords(register __i0 __y u_int16 *d, register __a0 u_int16 n);
```

Read *n* data byte pairs and copy them in big-endian format (first byte to MSBs) to *d*. This function will wait until there is enough data in the input buffer.

## 11 Document Version Changes

This chapter describes the most important changes to this document.

### 11.1 Version 1.01 for VS1011b, 2004-11-19

- Removed non-existing SCIMB\_POWERDOWN bit.
- Added SOIC-28 package to Chapters 5.1.3 and 5.2.2.

### 11.2 Version 1.00 for VS1011b, 2004-10-22

- Fully qualified values to tables in Chapter 4.
- Reassigned BGA-49 balls for pins DVDD2, DGND2 and DGND3 in Chapter 5.2.

### 11.3 Version 0.71 for VS1011, 2004-07-20

- Added instructions to add 100 k $\Omega$  pull-down resistor to unused GPIOs to Chapter 5.2.

### 11.4 Version 0.70 for VS1011, 2004-05-13

- Removed SM\_JUMP.

### 11.5 Version 0.62 for VS1011, 2004-03-24

- Rewrote and clarified Chapter 8.2, Supported Audio Codecs.

### 11.6 Version 0.61 for VS1011, 2004-03-11

- Added samplerate and bitrate tables to Chapter 8.6.9.

### 11.7 Version 0.6 for VS1011, 2004-02-13

- Added BGA-49 to Packages and Pin Descriptions (Chapter 5).
- Added new Chapter 8.2, Supported Audio Codecs.

## 12 Contact Information



VLSI Solution Oy  
Hermiankatu 6-8 C  
FIN-33720 Tampere  
FINLAND

Fax: +358-3-316 5220  
Phone: +358-3-316 5230  
Email: [sales@vlsi.fi](mailto:sales@vlsi.fi)  
URL: <http://www.vlsi.fi/>

Note: If you have questions, first see <http://www.vlsi.fi/vs1011/faq/> .