

VS1033 - MP3/AAC/WMA/MIDI AUDIO CODEC

Features

- Decodes MPEG 1 & 2 audio layer III (CBR +VBR +ABR); layers I & II optional; MPEG4/2 AAC-LC-2.0.0.0 (+PNS); WMA 4.0/4.1/7/8/9 all profiles (5-384 kbps); WAV (PCM + IMA ADPCM); General MIDI / SP-MIDI format 0 files
- Encodes IMA ADPCM from microphone or line input
- Streaming support for MP3 and WAV
- **EarSpeaker Spatial Processing**
- Bass and treble controls
- Operates with a single clock 12..13 MHz
- Can also be used with 24..26 MHz clocks
- Internal PLL clock multiplier
- Low-power operation
- High-quality on-chip stereo DAC with no phase error between channels
- Stereo earphone driver capable of driving a 30 Ω load
- Quiet power-on and power-off
- I2S interface for external DAC
- Separate operating voltages for analog, digital and I/O
- 5.5 KiB On-chip RAM for user code / data
- Serial control and data interfaces
- Can be used as a slave co-processor
- SPI flash boot for special applications
- UART for debugging purposes
- New functions may be added with software and 8 GPIO pins
- Lead-free RoHS-compliant package (Green)

Description

VS1033 is a single-chip MP3/AAC/WMA/MIDI audio decoder and ADPCM encoder. It contains a high-performance, proprietary low-power DSP processor core VS_DSP⁴, working data memory, 5 KiB instruction RAM and 0.5 KiB data RAM for user applications, serial control and input data interfaces, upto 8 general purpose I/O pins, an UART, as well as a high-quality variable-sample-rate mono ADC and stereo DAC, followed by an earphone amplifier and a common voltage buffer.

VS1033 receives its input bitstream through a serial input bus, which it listens to as a system slave. The input stream is decoded and passed through a digital volume control to an 18-bit oversampling, multi-bit, sigma-delta DAC. The decoding is controlled via a serial control bus. In addition to the basic decoding, it is possible to add application specific features, like DSP effects, to the user RAM memory.

EarSpeaker spatial processing provides more natural sound in headphone listening conditions. It widens the stereo image and positions the sound sources outside the listener's head.

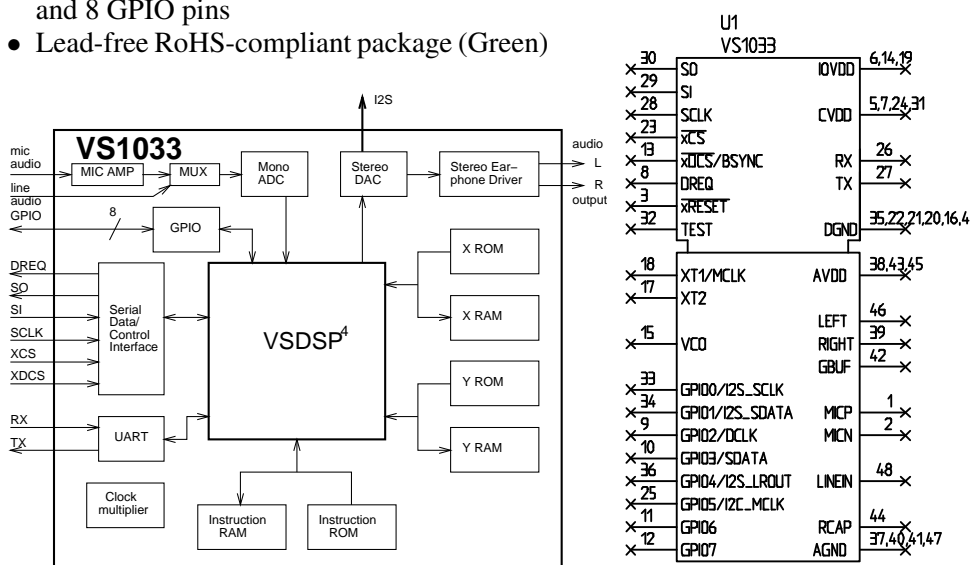

Contents

1 Licenses	9
2 Disclaimer	9
3 Definitions	9
4 Characteristics & Specifications	10
4.1 Absolute Maximum Ratings	10
4.2 Recommended Operating Conditions	10
4.3 Analog Characteristics	11
4.4 Power Consumption	12
4.5 Digital Characteristics	12
4.6 Switching Characteristics - Boot Initialization	12
5 Packages and Pin Descriptions	13
5.1 Packages	13
5.1.1 LQFP-48	13
5.1.2 BGA-49	13
5.2 LQFP-48 and BGA-49 Pin Descriptions	14
6 Connection Diagram, LQFP-48	16
7 SPI Buses	17
7.1 General	17
7.2 SPI Bus Pin Descriptions	17
7.2.1 VS1002 Native Modes (New Mode)	17

7.2.2	VS1001 Compatibility Mode	17
7.3	Data Request Pin DREQ	18
7.4	Serial Protocol for Serial Data Interface (SDI)	18
7.4.1	General	18
7.4.2	SDI in VS1002 Native Modes (New Mode)	18
7.4.3	SDI in VS1001 Compatibility Mode	19
7.4.4	Passive SDI Mode	19
7.5	Serial Protocol for Serial Command Interface (SCI)	19
7.5.1	General	19
7.5.2	SCI Read	20
7.5.3	SCI Write	20
7.5.4	SCI Multiple Write	21
7.6	SPI Timing Diagram	22
7.7	SPI Examples with SM_SDINEW and SM_SDISHARED set	23
7.7.1	Two SCI Writes	23
7.7.2	Two SDI Bytes	23
7.7.3	SCI Operation in Middle of Two SDI Bytes	24
8	Functional Description	25
8.1	Main Features	25
8.2	Supported Audio Codecs	25
8.2.1	Supported MP3 (MPEG layer III) Formats	25
8.2.2	Supported MP1 (MPEG layer I) Formats	26
8.2.3	Supported MP2 (MPEG layer II) Formats	26
8.2.4	Supported AAC (ISO/IEC 13818-7) Formats	27

8.2.5	Supported WMA Formats	28
8.2.6	Supported RIFF WAV Formats	29
8.2.7	Supported MIDI Formats	30
8.3	Data Flow of VS1033	32
8.4	EarSpeaker Spatial Processing	33
8.5	Serial Data Interface (SDI)	34
8.6	Serial Control Interface (SCI)	35
8.7	SCI Registers	35
8.7.1	SCIMODE (RW)	36
8.7.2	SCI_STATUS (RW)	38
8.7.3	SCI_BASS (RW)	38
8.7.4	SCI_CLOCKF (RW)	39
8.7.5	SCI_DECODE_TIME (RW)	40
8.7.6	SCI_AUDATA (RW)	40
8.7.7	SCI_WRAM (RW)	40
8.7.8	SCI_WRAMADDR (W)	40
8.7.9	SCI_HDAT0 and SCI_HDAT1 (R)	41
8.7.10	SCI_AIADDR (RW)	42
8.7.11	SCI_VOL (RW)	42
8.7.12	SCI_AICTRL[x] (RW)	43
9	Operation	44
9.1	Clocking	44
9.2	Hardware Reset	44
9.3	Software Reset	45

9.4	ADPCM Recording	46
9.4.1	Activating ADPCM mode	46
9.4.2	Reading IMA ADPCM Data	46
9.4.3	Adding a RIFF Header	47
9.4.4	Playing ADPCM Data	48
9.4.5	Sample Rate Considerations	48
9.4.6	AD Startup Time	48
9.4.7	Example Code	48
9.5	SPI Boot	50
9.6	Play/Decode	50
9.7	Feeding PCM data	51
9.8	Extra Parameters	52
9.8.1	Common Parameters	53
9.8.2	WMA	53
9.8.3	AAC	54
9.8.4	Midi	54
9.9	Fast Forward / Rewind	55
9.9.1	AAC - ADTS	55
9.9.2	AAC - ADIF, MP4	55
9.9.3	WMA	56
9.9.4	Midi	56
9.10	SDI Tests	57
9.10.1	Sine Test	57
9.10.2	Pin Test	57

9.10.3	Memory Test	58
9.10.4	SCI Test	58
10	VS1033 Registers	59
10.1	Who Needs to Read This Chapter	59
10.2	The Processor Core	59
10.3	VS1033 Memory Map	59
10.4	SCI Registers	59
10.5	Serial Data Registers	59
10.6	DAC Registers	60
10.7	GPIO Registers	61
10.8	Interrupt Registers	62
10.9	A/D Modulator Registers	63
10.10	Watchdog v1.0 2002-08-26	64
10.10.1	Registers	64
10.11	UART v1.1 2004-10-09	65
10.11.1	Registers	65
10.11.2	Status UARTx_STATUS	65
10.11.3	Data UARTx_DATA	66
10.11.4	Data High UARTx_DATAH	66
10.11.5	Divider UARTx_DIV	66
10.11.6	Interrupts and Operation	67
10.12	Timers v1.0 2002-04-23	68
10.12.1	Registers	68
10.12.2	Configuration TIMER_CONFIG	68

10.12.3 Configuration TIMER_ENABLE	69
10.12.4 Timer X Startvalue TIMER_Tx[L/H]	69
10.12.5 Timer X Counter TIMER_TxCNT[L/H]	69
10.12.6 Interrupts	69
10.13 I2S DAC Interface	70
10.13.1 Registers	70
10.13.2 Configuration I2S_CONFIG	70
10.14 System Vector Tags	71
10.14.1 AudioInt, 0x20	71
10.14.2 SciInt, 0x21	71
10.14.3 DataInt, 0x22	71
10.14.4 ModuInt, 0x23	71
10.14.5 TxInt, 0x24	72
10.14.6 RxInt, 0x25	72
10.14.7 Timer0Int, 0x26	72
10.14.8 Timer1Int, 0x27	72
10.14.9 UserCodec, 0x0	73
10.15 System Vector Functions	73
10.15.1 WriteIRam(), 0x2	73
10.15.2 ReadIRam(), 0x4	73
10.15.3 DataBytes(), 0x6	73
10.15.4 GetDataByte(), 0x8	74
10.15.5 GetDataWords(), 0xa	74

11 Document Version Changes 75

12 Contact Information

76

List of Figures

1	Pin Configuration, LQFP-48.	13
2	Pin Configuration, BGA-49.	13
3	Typical Connection Diagram Using LQFP-48.	16
4	BSYNC Signal - one byte transfer.	19
5	BSYNC Signal - two byte transfer.	19
6	SCI Word Read	20
7	SCI Word Write	20
8	SCI Multiple Word Write	21
9	SPI Timing Diagram.	22
10	Two SCI Operations.	23
11	Two SDI Bytes.	23
12	Two SDI Bytes Separated By an SCI Operation.	24
13	Data Flow of VS1033.	32
14	EarSpeaker externalized sound sources vs. normal inside-the-head sound	33
15	ADPCM Frequency Responses with 8 kHz sample rate.	37
16	User's Memory Map.	60
17	RS232 Serial Interface Protocol	65
18	I2S Interface, 192 kHz.	70

1 Licenses

MPEG Layer-3 audio decoding technology licensed from Fraunhofer IIS and Thomson.

Note: if you enable Layer I and Layer II decoding, you are liable for any patent issues that may arise from using these formats. Joint licensing of MPEG 1.0 / 2.0 Layer III does not cover all patents pertaining to layers I and II.

VS1033 contains WMA decoding technology from Microsoft.

This product is protected by certain intellectual property rights of Microsoft and cannot be used or further distributed without a license from Microsoft.

VS1033 contains AAC technology (ISO/IEC 13818-7) which cannot be used without a proper license from Via Licensing Corporation or individual patent holders.

To the best of our knowledge, if the end product does not play a specific format that otherwise would require a customer license: MPEG 1.0/2.0 layers I and II, WMA, or AAC, the respective license should not be required. Decoding of MPEG layers I and II are disabled by default, and WMA and AAC format exclusion can be easily performed based on the contents of the SCL_HDAT1 register.

2 Disclaimer

This is a *preliminary* datasheet. All properties and figures are subject to change.

3 Definitions

B Byte, 8 bits.

b Bit.

Ki “Kibi” = 2^{10} = 1024 (IEC 60027-2).

Mi “Mebi” = 2^{20} = 1048576 (IEC 60027-2).

VS_DSP VLSI Solution’s DSP core.

W Word. In VS_DSP, instruction words are 32-bit and data words are 16-bit wide.

4 Characteristics & Specifications

4.1 Absolute Maximum Ratings

Parameter	Symbol	Min	Max	Unit
Analog Positive Supply	AVDD	-0.3	3.6	V
Digital Positive Supply	CVDD	-0.3	2.7	V
I/O Positive Supply	IOVDD	-0.3	3.6	V
Current at Any Non-Power Pin ¹			±50	mA
Voltage at Any Digital Input		-0.3	IOVDD+0.3 ²	V
Operating Temperature		-40	+85	°C
Storage Temperature		-65	+150	°C

¹ Higher current can cause latch-up.

² Must not exceed 3.6 V.

4.2 Recommended Operating Conditions

Parameter	Symbol	Min	Typ	Max	Unit
Ambient Operating Temperature		-30		+85	°C
Analog and Digital Ground ¹	AGND DGND		0.0		V
Positive Analog	AVDD	2.7	2.8	3.6	V
Positive Digital	CVDD	2.4	2.5	2.7	V
I/O Voltage	IOVDD	CVDD-0.6V	2.8	3.6	V
Input Clock Frequency ²	XTALI	12	12.288	13	MHz
Input Clock Freq., SM_CLK_RANGE set ²	XTALI	24	24.576	26	MHz
Internal Clock Frequency	CLKI	12	36.864	50	MHz
Internal Clock Multiplier ³		1.0×	3.0×	4.5×	
Master Clock Duty Cycle		40	50	60	%

¹ Must be connected together as close the device as possible for maximum latch-up immunity.

² The maximum sample rate that can be played with correct speed is XTALI/256 (or XTALI/512 if SM_CLK_RANGE is set). Thus, XTALI must be at least 12.288 MHz (24.576 MHz) to be able to play 48 kHz at correct speed.

³ Reset value is 1.0×. Recommended SC_MULT=3.0×, SC_ADD=1.0× (SCI_CLOCKF=0x9000). Do not exceed Max CLKI.

4.3 Analog Characteristics

Unless otherwise noted: AVDD=2.7..2.85V, CVDD=2.4..2.7V, IOVDD=CVDD-0.6V..3.6V, TA=-30..+85°C, XTALI=12..13MHz, Internal Clock Multiplier 3.5×. DAC tested with 1307.894 Hz full-scale output sine wave, measurement bandwidth 20..20000 Hz, full analog output load: LEFT to GBUF 30 Ω, RIGHT to GBUF 30 Ω. Microphone test amplitude 30 mVpp per input pin, f=1 kHz. Line input test amplitude 2.2 Vpp, f=1 kHz. ADC sample rate 48 kHz.

Parameter	Symbol	Min	Typ	Max	Unit
DAC Resolution			18		bits
Total Harmonic Distortion	THD		0.1	0.4	%
Dynamic Range (DAC unmuted, A-weighted)	IDR		90		dB
S/N Ratio (full scale signal)	SNR	70	85		dB
Interchannel Isolation (Cross Talk)			75		dB
Interchannel Isolation (Cross Talk), with GBUF			40		dB
Interchannel Gain Mismatch		-0.5	±0.04	0.5	dB
Frequency Response		-0.1		0.1	dB
Full Scale Output Voltage (Peak-to-peak)		1.3	1.5 ¹	1.8	Vpp
Deviation from Linear Phase				5	°
Analog Output Load Resistance	AOLR	16	30 ²		Ω
Analog Output Load Capacitance ³				100	pF
Microphone input amplifier gain	MICG		26		dB
Microphone input amplitude, balanced			60	140 ⁴	mVpp
Microphone Total Harmonic Distortion	MTHD		0.02	0.10	%
Microphone S/N Ratio	MSNR	60	66		dB
Line input amplitude			2200	AVDD ⁴	mVpp
Line input Total Harmonic Distortion	LTHD		0.02	0.10	%
Line input S/N Ratio	LSNR	75	86		dB
Line and Microphone input impedances			100		kΩ

¹ 3.0 volts can be achieved with +-to-+ wiring for differential mono sound.

² AOLR may be much lower, but below *Typical* distortion performance may be compromised.

³ Requires ESD protection as shown in Figure 3.

⁴ Above typical amplitude Total Harmonic Distortion increases.

4.4 Power Consumption

Output at full volume. Internal clock multiplier 3.0×.

Reset	Min	Typ	Max	Unit
Power Supply Consumption AVDD		0.6	20 ¹	μA
Power Supply Consumption CVDD = 2.5V		3.7	40 ¹	μA
Power Supply Consumption IOVDD		3	12 ¹	μA
Sine Test	Min	Typ	Max	Unit
Power Supply Consumption AVDD, sine test, 30Ω + GBUF		36	45	mA
Power Supply Consumption CVDD = 2.5V		13	18	mA
MPEG 1.0 Layer-3 128 kbps music sample	Min	Typ	Max	Unit
Power Supply Consumption AVDD, no load		7		mA
Power Supply Consumption AVDD, output load 30Ω		11		mA
Power Supply Consumption AVDD, 30Ω + GBUF		16		mA
Power Supply Consumption CVDD = 2.5V		14		mA

¹ Numbers are this high only at maximum temperature +85 °C.

4.5 Digital Characteristics

Parameter	Symbol	Min	Typ	Max	Unit
High-Level Input Voltage		0.7×IOVDD		IOVDD+0.3 ¹	V
Low-Level Input Voltage		-0.2		0.3×IOVDD	V
High-Level Output Voltage at I _O = -1.0 mA ²		0.7×IOVDD			V
Low-Level Output Voltage at I _O = 1.0 mA ²				0.3×IOVDD	V
Input Leakage Current		-1.0		1.0	μA
SPI Input Clock Frequency ²				$\frac{CLKI}{7}$	MHz
Rise time of all output pins, load = 50 pF				50	ns

¹ Must not exceed 3.6V

² Exception: ±0.35 mA for XTALO.

³ Value for SCI reads. SCI and SDI writes allow $\frac{CLKI}{4}$.

4.6 Switching Characteristics - Boot Initialization

Parameter	Symbol	Min	Max	Unit
XRESET active time		2		XTALI
XRESET inactive to software ready		20000	50000 ¹	XTALI
Power on reset, rise time to CVDD		10		V/s

¹ DREQ rises when initialization is complete. You should not send any data or commands before that.

5 Packages and Pin Descriptions

5.1 Packages

Both LQFP-48 and BGA-49 are lead (Pb) free and also RoHS compliant packages. RoHS is a short name of *Directive 2002/95/EC on the restriction of the use of certain hazardous substances in electrical and electronic equipment*.

5.1.1 LQFP-48

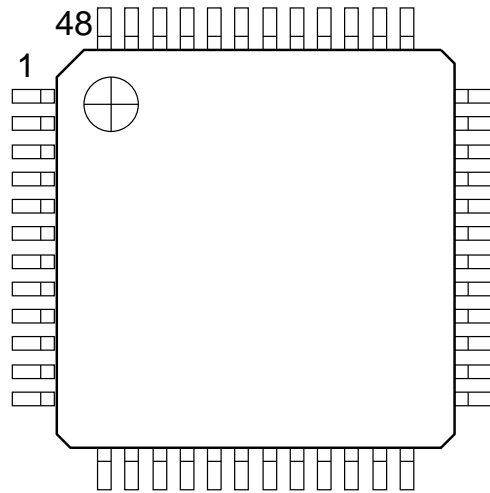

Figure 1: Pin Configuration, LQFP-48.

LQFP-48 package dimensions are at <http://www.vlsi.fi/>.

5.1.2 BGA-49

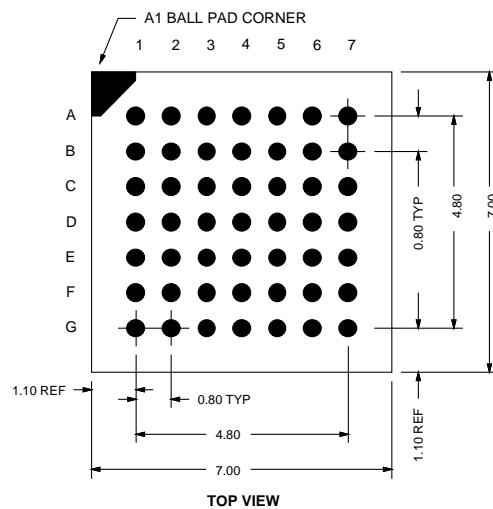

Figure 2: Pin Configuration, BGA-49.

BGA-49 package dimensions are at <http://www.vlsi.fi/>.

5.2 LQFP-48 and BGA-49 Pin Descriptions

Pad Name	LQFP Pin	BGA Ball	Pin Type	Function
MICP	1	C3	AI	Positive differential microphone input, self-biasing
MICN	2	C2	AI	Negative differential microphone input, self-biasing
XRESET	3	B1	DI	Active low asynchronous reset, schmitt-trigger input
DGND0	4	D2	DGND	Core & I/O ground
CVDD0	5	C1	CPWR	Core power supply
IOVDD0	6	D3	IOPWR	I/O power supply
CVDD1	7	D1	CPWR	Core power supply
DREQ	8	E2	DO	Data request, input bus
GPIO2 / DCLK ¹	9	E1	DIO	General purpose IO 2 / serial input data bus clock
GPIO3 / SDATA ¹	10	F2	DIO	General purpose IO 3 / serial data input
GPIO6	11	F1	DIO	General purpose IO 6
GPIO7	12	G1	DIO	General purpose IO 7
XDCS / BSYNC ¹	13	E3	DI	Data chip select / byte sync
IOVDD1	14	F3	IOPWR	I/O power supply
VCO	15	G2	DO	For testing only (Clock VCO output)
DGND1	16	F4	DGND	Core & I/O ground
XTALO	17	G3	AO	Crystal output
XTALI	18	E4	AI	Crystal input
IOVDD2	19	G4	IOPWR	I/O power supply
IOVDD3	(19)	F5	IOPWR	I/O power supply
DGND2	20	(G5)	DGND	Core & I/O ground
DGND3	21	G5	DGND	Core & I/O ground
DGND4	22	F6	DGND	Core & I/O ground
XCS	23	G6	DI	Chip select input (active low)
CVDD2	24	G7	CPWR	Core power supply
GPIO5 / I2S_MCLK ³	25	E5	DIO	General purpose IO 5 / I2S_MCLK
RX	26	E6	DI	UART receive, connect to IOVDD if not used
TX	27	F7	DO	UART transmit
SCLK	28	D6	DI	Clock for serial bus
SI	29	E7	DI	Serial input
SO	30	D5	DO3	Serial output
CVDD3	31	D7	CPWR	Core power supply
TEST	32	C6	DI	Reserved for test, connect to IOVDD
GPIO0 / I2S_SCLK ³	33	C7	DIO	General purpose IO 0 (SPIBOOT) / I2S_SCLK use 100 k Ω pull-down resistor ²
GPIO1 / I2S_SDATA ³	34	B6	DIO	General purpose IO 1 / I2S_SDATA
GND	35	B7	DGND	I/O Ground
GPIO4 / I2S_LROUT ³	36	A7	DIO	General purpose IO 4 / I2S_LROUT
AGND0	37	C5	APWR	Analog ground, low-noise reference
AVDD0	38	B5	APWR	Analog power supply
RIGHT	39	A6	AO	Right channel output
AGND1	40	B4	APWR	Analog ground
AGND2	41	A5	APWR	Analog ground
GBUF	42	C4	AO	Common buffer for headphones, do NOT connect to ground!
AVDD1	43	A4	APWR	Analog power supply
RCAP	44	B3	AIO	Filtering capacitance for reference
AVDD2	45	A3	APWR	Analog power supply
LEFT	46	B2	AO	Left channel output
AGND3	47	A2	APWR	Analog ground
LINEIN	48	A1	AI	Line input

¹ First pin function is active in New Mode, latter in Compatibility Mode.

² Unless pull-down resistor is used, SPI Boot is tried. See Chapter 9.5 for details.

³ If I2S_CF_ENA is '0' the pins are used for GPIO. See Chapter 10.13 for details.

Pin types:

Type	Description
DI	Digital input, CMOS Input Pad
DO	Digital output, CMOS Input Pad
DIO	Digital input/output
DO3	Digital output, CMOS Tri-stated Output Pad
AI	Analog input

Type	Description
AO	Analog output
AIO	Analog input/output
APWR	Analog power supply pin
DGND	Core or I/O ground pin
CPWR	Core power supply pin
IOPWR	I/O power supply pin

In BGA-49, D4 is a no-connect ball.

6 Connection Diagram, LQFP-48

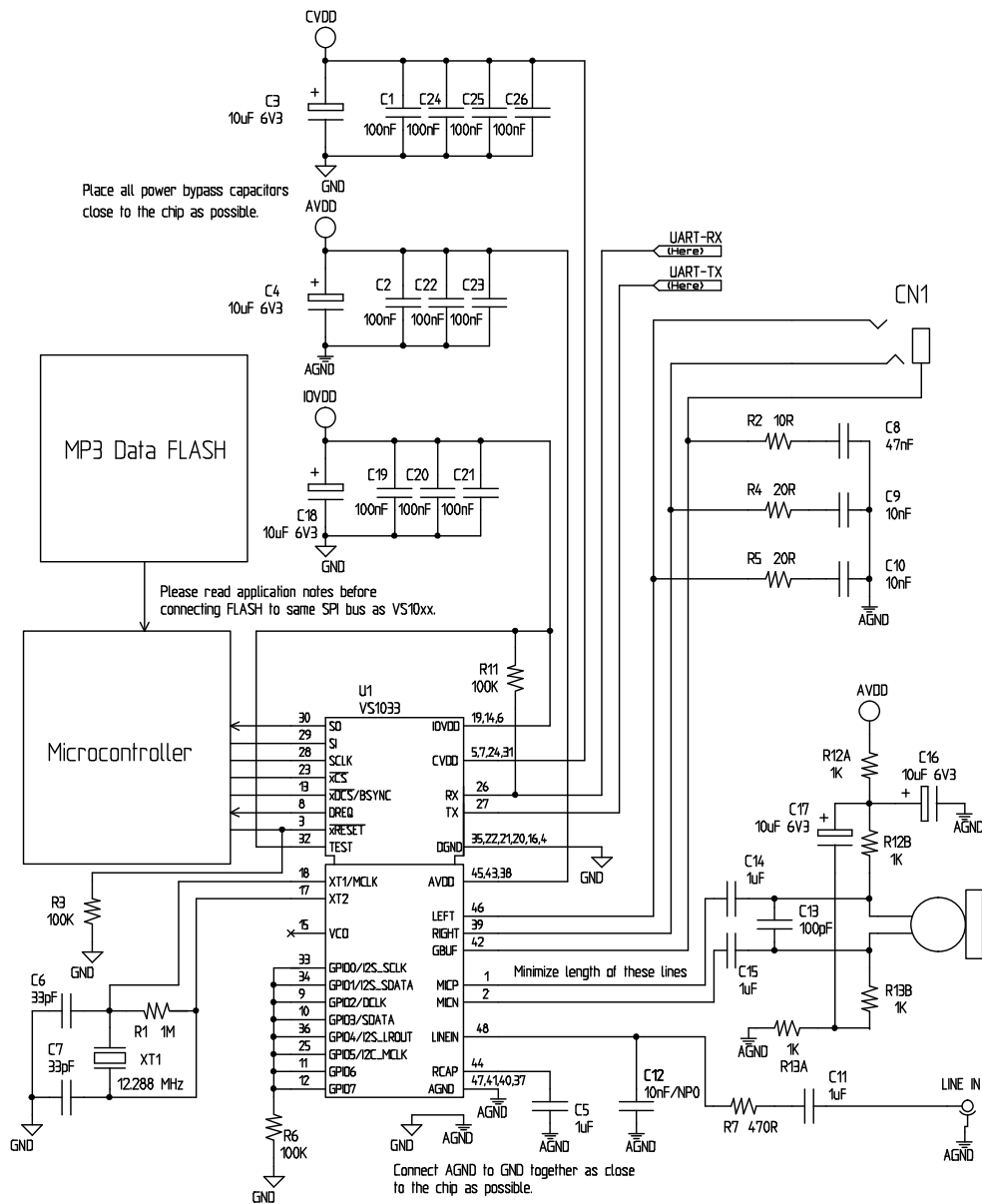

Figure 3: Typical Connection Diagram Using LQFP-48.

The common buffer GBUF can be used for common voltage (1.24 V) for earphones. This will eliminate the need for large isolation capacitors on line outputs, and thus the audio output pins from VS1033 may be connected directly to the earphone connector.

GBUF must NOT be connected to ground in any circumstance. If GBUF is not used, LEFT and RIGHT must be provided with coupling capacitors. To keep GBUF stable, you should always have the resistor and capacitor even when GBUF is not used. See application notes for details.

Unused GPIO pins should have a pull-down resistor. If UART is not used, RX should be connected to IOVDD and TX be unconnected. Do not connect any external load to XTALO.

Note: This connection assumes SM_SDINEW is active (see Chapter 8.7.1). If also SM_SDISHARE is used, xDCS should be tied low or high (see Chapter 7.2.1).

7 SPI Buses

7.1 General

The SPI Bus - that was originally used in some Motorola devices - has been used for both VS1033's Serial Data Interface SDI (Chapters 7.4 and 8.5) and Serial Control Interface SCI (Chapters 7.5 and 8.6).

7.2 SPI Bus Pin Descriptions

7.2.1 VS1002 Native Modes (New Mode)

These modes are active on VS1033 when SM_SDINEW is set to 1 (default at startup). DCLK and SDATA are not used for data transfer and they can be used as general-purpose I/O pins (GPIO2 and GPIO3). BSYNC function changes to data interface chip select (XDCS).

SDI Pin	SCI Pin	Description
XDCS	XCS	Active low chip select input. A high level forces the serial interface into standby mode, ending the current operation. A high level also forces serial output (SO) to high impedance state. If SM_SDISHARE is 1, pin XDCS is not used, but the signal is generated internally by inverting XCS.
SCK		Serial clock input. The serial clock is also used internally as the master clock for the register interface. SCK can be gated or continuous. In either case, the first rising clock edge after XCS has gone low marks the first bit to be written.
SI		Serial input. If a chip select is active, SI is sampled on the rising CLK edge.
-	SO	Serial output. In reads, data is shifted out on the falling SCK edge. In writes SO is at a high impedance state.

7.2.2 VS1001 Compatibility Mode

This mode is active when SM_SDINEW is set to 0. In this mode, DCLK, SDATA and BSYNC are active.

SDI Pin	SCI Pin	Description
-	XCS	Active low chip select input. A high level forces the serial interface into standby mode, ending the current operation. A high level also forces serial output (SO) to high impedance state.
BSYNC	-	SDI data is synchronized with a rising edge of BSYNC.
DCLK	SCK	Serial clock input. The serial clock is also used internally as the master clock for the register interface. SCK can be gated or continuous. In either case, the first rising clock edge after XCS has gone low marks the first bit to be written.
SDATA	SI	Serial input. SI is sampled on the rising SCK edge, if XCS is low.
-	SO	Serial output. In reads, data is shifted out on the falling SCK edge. In writes SO is at a high impedance state.

7.3 Data Request Pin DREQ

The DREQ pin/signal is used to signal if VS1033's 2048-byte FIFO is capable of receiving data. If DREQ is high, VS1033 can take at least 32 bytes of SDI data or one SCI command. DREQ is turned low when the stream buffer is too full and for the duration of a SCI command.

Because of the 32-byte safety area, the sender may send up to 32 bytes of SDI data at a time without checking the status of DREQ, making controlling VS1033 easier for low-speed microcontrollers.

Note: DREQ may turn low or high at any time, even during a byte transmission. Thus, DREQ should only be used to decide whether to send more bytes. It does not need to abort a transmission that has already started.

Note: In VS10XX products up to VS1002, DREQ was only used for SDI. In VS1003 and VS1033 DREQ is also used to tell the status of SCI.

There are cases when you still want to send SCI commands when DREQ is low. Because DREQ is shared between SDI and SCI, you can not determine if a SCI command has been executed if SDI is not ready to receive. In this case you need a long enough delay after every SCI command to make certain none of them is missed. The SCI Registers table in section 8.7 gives the worst-case handling time for each SCI register write.

7.4 Serial Protocol for Serial Data Interface (SDI)

7.4.1 General

The serial data interface operates in slave mode so DCLK signal must be generated by an external circuit.

Data (SDATA signal) can be clocked in at either the rising or falling edge of DCLK (Chapter 8.7).

VS1033 assumes its data input to be byte-synchronized. SDI bytes may be transmitted either MSb or LSb first, depending of contents of SCI_MODE (Chapter 8.7.1).

The firmware is able to accept the maximum bitrate the SDI supports.

7.4.2 SDI in VS1002 Native Modes (New Mode)

In VS1002 native modes (SM_NEWMODE is 1), byte synchronization is achieved by XDCS. The state of XDCS may not change while a data byte transfer is in progress. To always maintain data synchronization even if there may be glitches in the boards using VS1033, it is recommended to turn XDCS every now and then, for instance once after every flash data block or a few kilobytes, just to keep sure the host and VS1033 are in sync.

If SM_SDISHARE is 1, the XDCS signal is internally generated by inverting the XCS input.

For new designs, using VS1002 native modes are recommended.

7.4.3 SDI in VS1001 Compatibility Mode

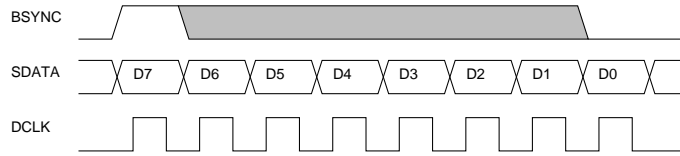

Figure 4: BSYNC Signal - one byte transfer.

When VS1033 is running in VS1001 compatibility mode, a BSYNC signal must be generated to ensure correct bit-alignment of the input bitstream. The first DCLK sampling edge (rising or falling, depending on selected polarity), during which the BSYNC is high, marks the first bit of a byte (LSB, if LSB-first order is used, MSB, if MSB-first order is used). If BSYNC is '1' when the last bit is received, the receiver stays active and next 8 bits are also received.

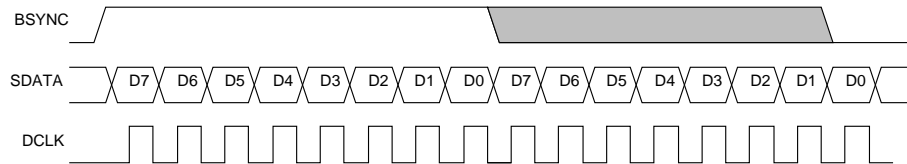

Figure 5: BSYNC Signal - two byte transfer.

7.4.4 Passive SDI Mode

If SM_NEWMODE is 0 and SM_SDISHARE is 1, the operation is otherwise like the VS1001 compatibility mode, but bits are only received while the BSYNC signal is '1'. Rising edge of BSYNC is still used for synchronization.

7.5 Serial Protocol for Serial Command Interface (SCI)

7.5.1 General

The serial bus protocol for the Serial Command Interface SCI (Chapter 8.6) consists of an instruction byte, address byte and one 16-bit data word. Each read or write operation can read or write a single register. Data bits are read at the rising edge, so the user should update data at the falling edge. Bytes are always send MSb first. XCS should be low for the full duration of the operation, but you can have pauses between bits if needed.

The operation is specified by an 8-bit instruction opcode. The supported instructions are read and write. See table below.

Instruction		
Name	Opcode	Operation
READ	0b0000 0011	Read data
WRITE	0b0000 0010	Write data

Note: VS1033 sets DREQ low after each SCI operation. The duration depends on the operation. It is not allowed to finish a new SCI/SDI operation before DREQ is high again.

7.5.2 SCI Read

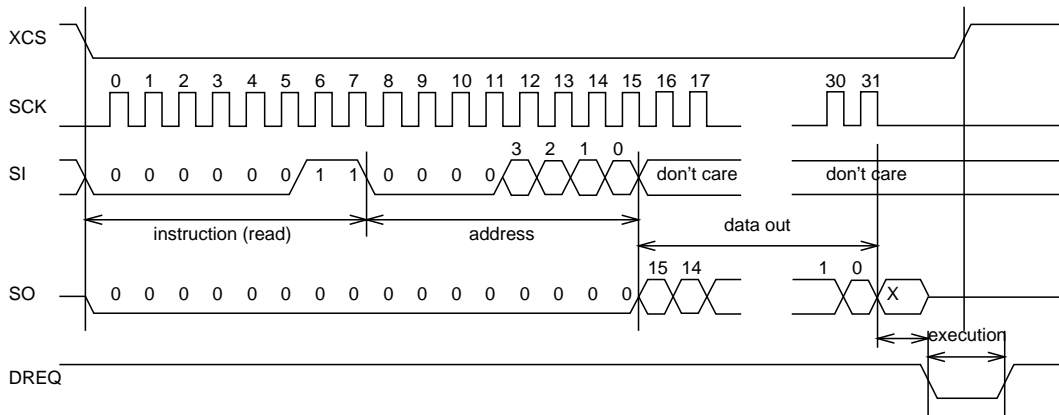

Figure 6: SCI Word Read

VS1033 registers are read from using the following sequence, as shown in Figure 6. First, XCS line is pulled low to select the device. Then the READ opcode (0x3) is transmitted via the SI line followed by an 8-bit word address. After the address has been read in, any further data on SI is ignored by the chip. The 16-bit data corresponding to the received address will be shifted out onto the SO line.

XCS should be driven high after data has been shifted out.

DREQ is driven low for a short while when in a read operation by the chip. This is a very short time and doesn't require special user attention.

7.5.3 SCI Write

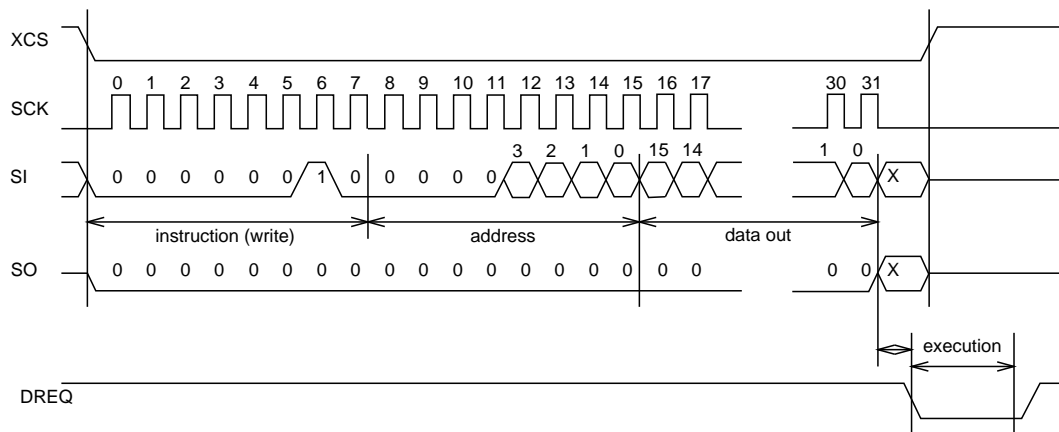

Figure 7: SCI Word Write

VS1033 registers are written from using the following sequence, as shown in Figure 7. First, XCS line is pulled low to select the device. Then the WRITE opcode (0x2) is transmitted via the SI line followed by an 8-bit word address.

After the word has been shifted in and the last clock has been sent, XCS should be pulled high to end the WRITE sequence.

After the last bit has been sent, DREQ is driven low for the duration of the register update, marked “execution” in the figure. The time varies depending on the register and its contents (see table in Chapter 8.7 for details). If the maximum time is longer than what it takes from the microcontroller to feed the next SCI command or SDI byte, status of DREQ must be checked before finishing the next SCI/SDI operation.

7.5.4 SCI Multiple Write

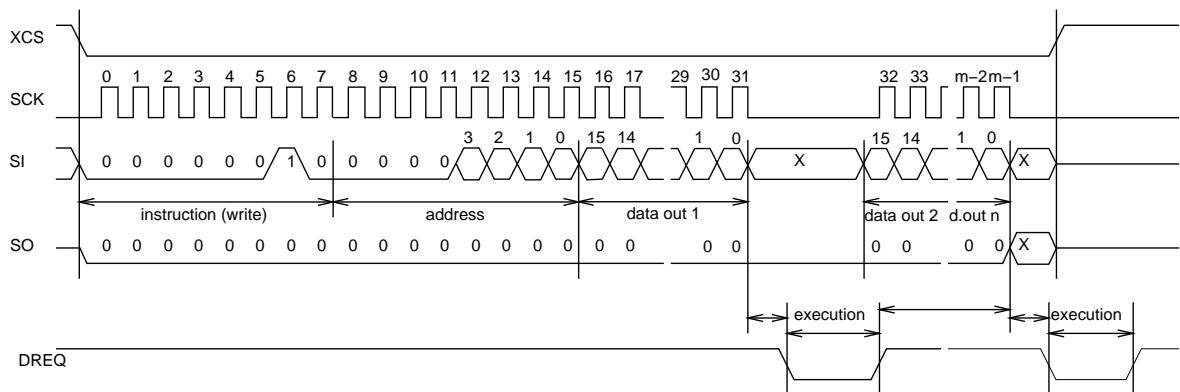

Figure 8: SCI Multiple Word Write

VS1033 allows for the user to send multiple words to the same SCI register, which allows fast SCI uploads, shown in Figure 8. The main difference to a single write is that instead of bringing XCS up after sending the last bit of a data word, the next data word is sent immediately. After the last data word, XCS is driven high as with a single word write.

After the last bit of a word has been sent, DREQ is driven low for the duration of the register update, marked “execution” in the figure. The time varies depending on the register and its contents (see table in Chapter 8.7 for details). If the maximum time is longer than what it takes from the microcontroller to feed the next SCI command or SDI byte, status of DREQ must be checked before finishing the next SCI/SDI operation.

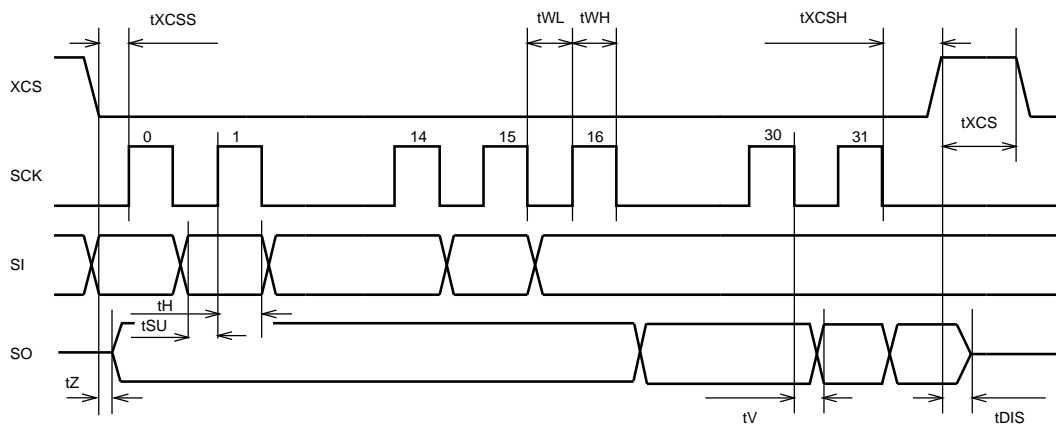

Figure 9: SPI Timing Diagram.

7.6 SPI Timing Diagram

Symbol	Min	Max	Unit
tXCSS	5		ns
tSU	0		ns
tH	2		CLKI cycles
tZ	0		ns
tWL	2		CLKI cycles
tWH	2		CLKI cycles
tV	2 (+25 ns ¹)		CLKI cycles
tXCSH	1		CLKI cycles
tXCS	2		CLKI cycles
tDIS		10	ns

¹ 25ns is when pin loaded with 100pF capacitance. The time is shorter with lower capacitance.

Note: Although the timing is derived from the internal clock CLKI, the system always starts up in 1.0× mode, thus CLKI=XTALI. After you have configured a higher clock through SCL_CLOCKF and waited for DREQ to rise, you can use a higher SPI speed as well.

Note: Because $tWL + tWH + tH$ is $6 \times \text{CLKI} + 25$ ns, the maximum speed for SCI reads is $\text{CLKI}/7$.

7.7 SPI Examples with SM_SDINEW and SM_SDISHARED set

7.7.1 Two SCI Writes

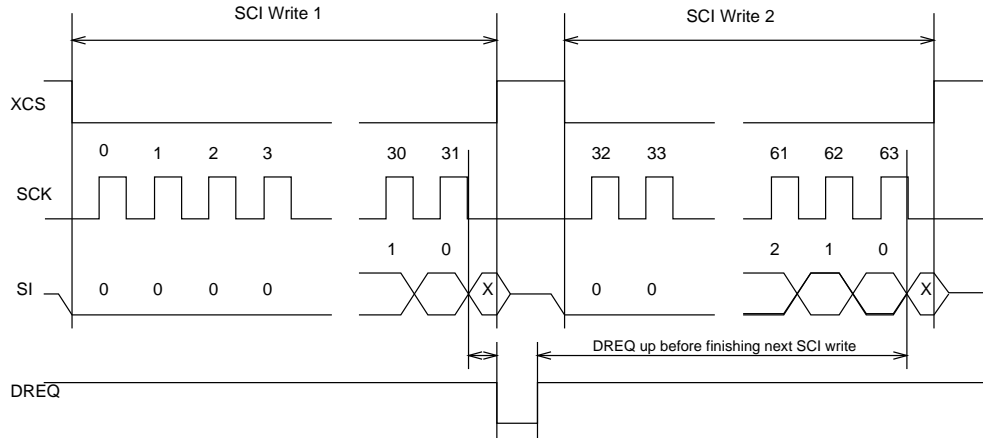

Figure 10: Two SCI Operations.

Figure 10 shows two consecutive SCI operations. Note that xCS *must* be raised to inactive state between the writes. Also DREQ must be respected as shown in the figure.

7.7.2 Two SDI Bytes

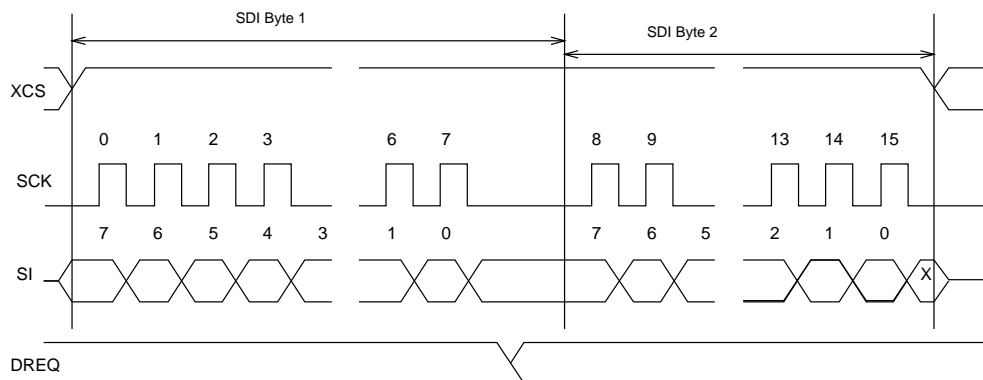

Figure 11: Two SDI Bytes.

SDI data is synchronized with a raising edge of xCS as shown in Figure 11. However, every byte doesn't need separate synchronization.

7.7.3 SCI Operation in Middle of Two SDI Bytes

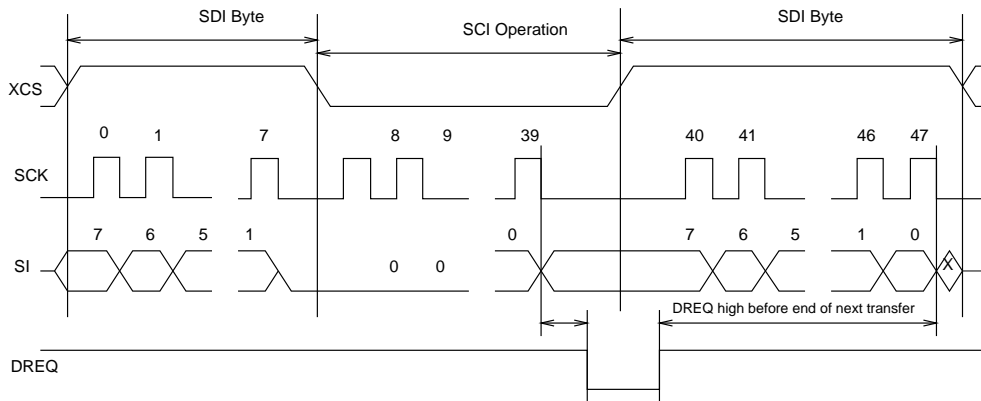

Figure 12: Two SDI Bytes Separated By an SCI Operation.

Figure 12 shows how an SCI operation is embedded in between SDI operations. xCS edges are used to synchronize both SDI and SCI. Remember to respect DREQ as shown in the figure.

8 Functional Description

8.1 Main Features

VS1033 is based on a proprietary digital signal processor, VS_DSP. It contains all the code and data memory needed for MP3, AAC, WMA and WAV PCM + ADPCM audio decoding, MIDI synthesizer, together with serial interfaces, a multirate stereo audio DAC and analog output amplifiers and filters. Also ADPCM audio encoding is supported using a microphone amplifier and A/D converter. A UART is provided for debugging purposes.

8.2 Supported Audio Codecs

Conventions	
Mark	Description
+	Format is supported
-	Format exists but is not supported
	Format doesn't exist

8.2.1 Supported MP3 (MPEG layer III) Formats

MPEG 1.0¹:

Samplerate / Hz	Bitrate / kbit/s													
	32	40	48	56	64	80	96	112	128	160	192	224	256	320
48000	+	+	+	+	+	+	+	+	+	+	+	+	+	+
44100	+	+	+	+	+	+	+	+	+	+	+	+	+	+
32000	+	+	+	+	+	+	+	+	+	+	+	+	+	+

MPEG 2.0¹:

Samplerate / Hz	Bitrate / kbit/s													
	8	16	24	32	40	48	56	64	80	96	112	128	144	160
24000	+	+	+	+	+	+	+	+	+	+	+	+	+	+
22050	+	+	+	+	+	+	+	+	+	+	+	+	+	+
16000	+	+	+	+	+	+	+	+	+	+	+	+	+	+

MPEG 2.5¹:

Samplerate / Hz	Bitrate / kbit/s													
	8	16	24	32	40	48	56	64	80	96	112	128	144	160
12000	+	+	+	+	+	+	+	+	+	+	+	+	+	+
11025	+	+	+	+	+	+	+	+	+	+	+	+	+	+
8000	+	+	+	+	+	+	+	+	+	+	+	+	+	+

¹ Also all variable bitrate (VBR) formats are supported.

8.2.2 Supported MP1 (MPEG layer I) Formats

Note: Layer I / II decoding must be specifically enabled from SCI_MODE register.

MPEG 1.0:

Samplerate / Hz	Bitrate / kbit/s													
	32	64	96	128	160	192	224	256	288	320	352	384	416	448
48000	+	+	+	+	+	+	+	+	+	+	+	+	+	+
44100	+	+	+	+	+	+	+	+	+	+	+	+	+	+
32000	+	+	+	+	+	+	+	+	+	+	+	+	+	+

MPEG 2.0:

Samplerate / Hz	Bitrate / kbit/s													
	32	48	56	64	80	96	112	128	144	160	176	192	224	256
24000	?	?	?	?	?	?	?	?	?	?	?	?	?	?
22050	?	?	?	?	?	?	?	?	?	?	?	?	?	?
16000	?	?	?	?	?	?	?	?	?	?	?	?	?	?

8.2.3 Supported MP2 (MPEG layer II) Formats

Note: Layer I / II decoding must be specifically enabled from SCI_MODE register.

MPEG 1.0:

Samplerate / Hz	Bitrate / kbit/s													
	32	48	56	64	80	96	112	128	160	192	224	256	320	384
48000	+	+	+	+	+	+	+	+	+	+	+	+	+	+
44100	+	+	+	+	+	+	+	+	+	+	+	+	+	+
32000	+	+	+	+	+	+	+	+	+	+	+	+	+	+

MPEG 2.0:

Samplerate / Hz	Bitrate / kbit/s													
	8	16	24	32	40	48	56	64	80	96	112	128	144	160
24000	+	+	+	+	+	+	+	+	+	+	+	+	+	+
22050	+	+	+	+	+	+	+	+	+	+	+	+	+	+
16000	+	+	+	+	+	+	+	+	+	+	+	+	+	+

8.2.4 Supported AAC (ISO/IEC 13818-7) Formats

VS1033 decodes MPEG2-AAC-LC-2.0.0.0 and MPEG4-AAC-LC-2.0.0.0 streams, i.e. the low complexity profile with maximum of two channels can be decoded. If a stream contains more than one element and/or element type, you can select which one to decode from the 16 single-channel, 16 channel-pair, and 16 low-frequency elements. The default is to select the first one that appears in the stream.

Dynamic range control (DRC) is supported and can be controlled by the user to limit or enhance the dynamic range of the material that has DRC information.

Both Sine window and Kaiser-Bessel-derived window are supported.

For MPEG4 pseudo-random noise substitution (PNS) is supported. Short frames (120 and 960 samples) are not supported.

For AAC the streaming ADTS format is recommended. This format allows easy rewind and fast forward because resynchronization is easily possible.

In addition to ADTS (.aac), MPEG2 ADIF (.aac) and MPEG4 AUDIO (.mp4 / .m4a) files are played, but these formats are less suitable for rewind and fast forward operations. You can still implement these features by using the safe jump points table and seek mechanism provided, or using slightly less robust but much easier automatic resync mechanism (see Section 9.9).

Note: To be able to play the .mp4 and .m4a files, the **mdat** atom must be the last atom in the MP4 file. Because VS1033 receives all data as a stream, all metadata must be available before the music data is received. Several MP4 file formatters do not satisfy this requirement and some kind of conversion is required. This is also why the streamable ADTS format is recommended.

Programs exist that optimize the .mp4 and .m4a into so-called *streamable* format that has the **mdat** atom last in the file, and thus suitable for web servers' audio streaming. You can use this kind of tool to process files for VS1033 too. For example `mp4creator -optimize file.mp4`.

AAC^{1,2}:

Samplerate / Hz	Maximum Bitrate kbit/s - for 2 channels								
	≤96	132	144	192	264	288	384	529	≥576
48000	+	+	+	+	+	+	+	+	+
44100	+	+	+	+	+	+	+	+	
32000	+	+	+	+	+	+	+		
24000	+	+	+	+	+	+			
22050	+	+	+	+	+				
16000	+	+	+	+					
12000	+	+	+						
11025	+	+							
8000	+								

¹ 64000 Hz, 88200 Hz, and 96000 Hz AAC files are played but with wrong speed.

² Also all variable bitrate (VBR) formats are supported. Note that the table gives the maximum bitrate allowed for two channels for a specific sample rate as defined by the AAC specification. The decoder does not actually have a lower or upper limit.

8.2.5 Supported WMA Formats

Windows Media Audio codec versions 2, 7, 8, and 9 are supported. All WMA profiles (L1, L2, and L3) are supported. Previously streams were separated into Classes 1, 2a, 2b, and 3. The decoder has passed Microsoft's conformance testing program.

WMA 4.0 / 4.1:

Samplerate / Hz	Bitrate / kbit/s																
	5	6	8	10	12	16	20	22	32	40	48	64	80	96	128	160	192
8000	+	+	+		+												
11025			+	+													
16000				+	+	+	+										
22050						+	+	+	+								
32000							+	+	+	+	+	+					
44100									+		+	+	+	+	+	+	
48000															+	+	

WMA 7:

Samplerate / Hz	Bitrate / kbit/s																
	5	6	8	10	12	16	20	22	32	40	48	64	80	96	128	160	192
8000	+	+	+		+												
11025			+	+													
16000				+	+	+	+										
22050						+	+	+	+								
32000							+		+	+	+						
44100									+		+	+	+	+	+	+	+
48000															+	+	

WMA 8:

Samplerate / Hz	Bitrate / kbit/s																
	5	6	8	10	12	16	20	22	32	40	48	64	80	96	128	160	192
8000	+	+	+		+												
11025			+	+													
16000				+	+	+	+										
22050						+	+	+	+								
32000							+		+	+	+						
44100									+		+	+	+	+	+	+	+
48000											+		+	+	+	+	+

WMA 9:

Samplerate / Hz	Bitrate / kbit/s																		
	5	6	8	10	12	16	20	22	32	40	48	64	80	96	128	160	192	256	320
8000	+	+	+		+														
11025			+	+															
16000				+	+	+	+												
22050						+	+	+	+										
32000							+		+	+	+								
44100							+		+		+	+	+	+	+	+	+	+	+
48000											+		+	+	+	+	+		

In addition to these expected WMA decoding profiles, all other bitrate and samplerate combinations are supported, including variable bitrate WMA streams. Note that WMA does not consume the bitstream as evenly as MP3, so you need a higher peak transfer capability for clean playback at the same bitrate.

8.2.6 Supported RIFF WAV Formats

The most common RIFF WAV subformats are supported.

Format	Name	Supported	Comments
0x01	PCM	+	16 and 8 bits, any sample rate \leq 48kHz
0x02	ADPCM	-	
0x03	IEEE_FLOAT	-	
0x06	ALAW	-	
0x07	MULAW	-	
0x10	OKI_ADPCM	-	
0x11	IMA_ADPCM	+	Any sample rate \leq 48kHz
0x15	DIGISTD	-	
0x16	DIGIFIX	-	
0x30	DOLBY_AC2	-	
0x31	GSM610	-	
0x3b	ROCKWELL_ADPCM	-	
0x3c	ROCKWELL_DIGITALK	-	
0x40	G721_ADPCM	-	
0x41	G728_CELP	-	
0x50	MPEG	-	
0x55	MPEGLAYER3	+	For supported MP3 modes, see Chapter 8.2.1
0x64	G726_ADPCM	-	
0x65	G722_ADPCM	-	

8.2.7 Supported MIDI Formats

General MIDI and SP-MIDI format 0 files are played. Format 1 and 2 files must be converted to format 0 by the user. The maximum simultaneous polyphony is 40. Actual polyphony depends on the internal clock rate (which is user-selectable), the instruments used, whether the reverb effect is enabled, and the possible global postprocessing effects enabled, such as bass enhancer, treble control or EarSpeaker spatial processing. The polyphony restriction algorithm makes use of the SP-MIDI MIP table, if present.

36.86 MHz ($3.0\times$ input clock) achieves 16-26 simultaneous sustained notes. The instantaneous amount of notes can be larger. 36 MHz is a fair compromise between power consumption and quality, but higher clocks can be used to increase the polyphony.

Reverb effect can be controlled by the user. In addition to reverb automatic and reverb off modes, 14 different decay times can be selected. These roughly correspond to different room sizes. Also, each midi song decides how much effect each instrument gets. Because the reverb effect uses about 4 MHz of processing power the automatic control enables reverb only when the internal clock is at least $3.0\times$.

When EarSpeaker spatial processing is active, MIDI reverb is not used.

New instruments have been implemented in addition to the 36 that are available in VS1003. VS1033 now has unique instruments in the whole GM1 instrument set and one bank of GM2 percussions.

VS1033 Melodic Instruments (GM1)			
1 Acoustic Grand Piano	33 Acoustic Bass	65 Soprano Sax	97 Rain (FX 1)
2 Bright Acoustic Piano	34 Electric Bass (finger)	66 Alto Sax	98 Sound Track (FX 2)
3 Electric Grand Piano	35 Electric Bass (pick)	67 Tenor Sax	99 Crystal (FX 3)
4 Honky-tonk Piano	36 Fretless Bass	68 Baritone Sax	100 Atmosphere (FX 4)
5 Electric Piano 1	37 Slap Bass 1	69 Oboe	101 Brightness (FX 5)
6 Electric Piano 2	38 Slap Bass 2	70 English Horn	102 Goblins (FX 6)
7 Harpsichord	39 Synth Bass 1	71 Bassoon	103 Echoes (FX 7)
8 Clavi	40 Synth Bass 2	72 Clarinet	104 Sci-fi (FX 8)
9 Celesta	41 Violin	73 Piccolo	105 Sitar
10 Glockenspiel	42 Viola	74 Flute	106 Banjo
11 Music Box	43 Cello	75 Recorder	107 Shamisen
12 Vibraphone	44 Contrabass	76 Pan Flute	108 Koto
13 Marimba	45 Tremolo Strings	77 Blown Bottle	109 Kalimba
14 Xylophone	46 Pizzicato Strings	78 Shakuhachi	110 Bag Pipe
15 Tubular Bells	47 Orchestral Harp	79 Whistle	111 Fiddle
16 Dulcimer	48 Timpani	80 Ocarina	112 Shanai
17 Drawbar Organ	49 String Ensembles 1	81 Square Lead (Lead 1)	113 Tinkle Bell
18 Percussive Organ	50 String Ensembles 2	82 Saw Lead (Lead)	114 Agogo
19 Rock Organ	51 Synth Strings 1	83 Calliope Lead (Lead 3)	115 Pitched Percussion
20 Church Organ	52 Synth Strings 2	84 Chiff Lead (Lead 4)	116 Woodblock
21 Reed Organ	53 Choir Aahs	85 Charang Lead (Lead 5)	117 Taiko Drum
22 Accordion	54 Voice Oohs	86 Voice Lead (Lead 6)	118 Melodic Tom
23 Harmonica	55 Synth Voice	87 Fifths Lead (Lead 7)	119 Synth Drum
24 Tango Accordion	56 Orchestra Hit	88 Bass + Lead (Lead 8)	120 Reverse Cymbal
25 Acoustic Guitar (nylon)	57 Trumpet	89 New Age (Pad 1)	121 Guitar Fret Noise
26 Acoustic Guitar (steel)	58 Trombone	90 Warm Pad (Pad 2)	122 Breath Noise
27 Electric Guitar (jazz)	59 Tuba	91 Polysynth (Pad 3)	123 Seashore
28 Electric Guitar (clean)	60 Muted Trumpet	92 Choir (Pad 4)	124 Bird Tweet
29 Electric Guitar (muted)	61 French Horn	93 Bowed (Pad 5)	125 Telephone Ring
30 Overdriven Guitar	62 Brass Section	94 Metallic (Pad 6)	126 Helicopter
31 Distortion Guitar	63 Synth Brass 1	95 Halo (Pad 7)	127 Applause
32 Guitar Harmonics	64 Synth Brass 2	96 Sweep (Pad 8)	128 Gunshot

VS1033 Percussion Instruments (GM1+GM2)			
27 High Q	43 High Floor Tom	59 Ride Cymbal 2	75 Claves
28 Slap	44 Pedal Hi-hat [EXC 1]	60 High Bongo	76 Hi Wood Block
29 Scratch Push [EXC 7]	45 Low Tom	61 Low Bongo	77 Low Wood Block
30 Scratch Pull [EXC 7]	46 Open Hi-hat [EXC 1]	62 Mute Hi Conga	78 Mute Cuica [EXC 4]
31 Sticks	47 Low-Mid Tom	63 Open Hi Conga	79 Open Cuica [EXC 4]
32 Square Click	48 High Mid Tom	64 Low Conga	80 Mute Triangle [EXC 5]
33 Metronome Click	49 Crash Cymbal 1	65 High Timbale	81 Open Triangle [EXC 5]
34 Metronome Bell	50 High Tom	66 Low Timbale	82 Shaker
35 Acoustic Bass Drum	51 Ride Cymbal 1	67 High Agogo	83 Jingle bell
36 Bass Drum 1	52 Chinese Cymbal	68 Low Agogo	84 Bell tree
37 Side Stick	53 Ride Bell	69 Cabasa	85 Castanets
38 Acoustic Snare	54 Tambourine	70 Maracas	86 Mute Surdo [EXC 6]
39 Hand Clap	55 Splash Cymbal	71 Short Whistle [EXC 2]	87 Open Surdo [EXC 6]
40 Electric Snare	56 Cowbell	72 Long Whistle [EXC 2]	
41 Low Floor Tom	57 Crash Cymbal 2	73 Short Guiro [EXC 3]	
42 Closed Hi-hat [EXC 1]	58 Vibra-slap	74 Long Guiro [EXC 3]	

8.3 Data Flow of VS1033

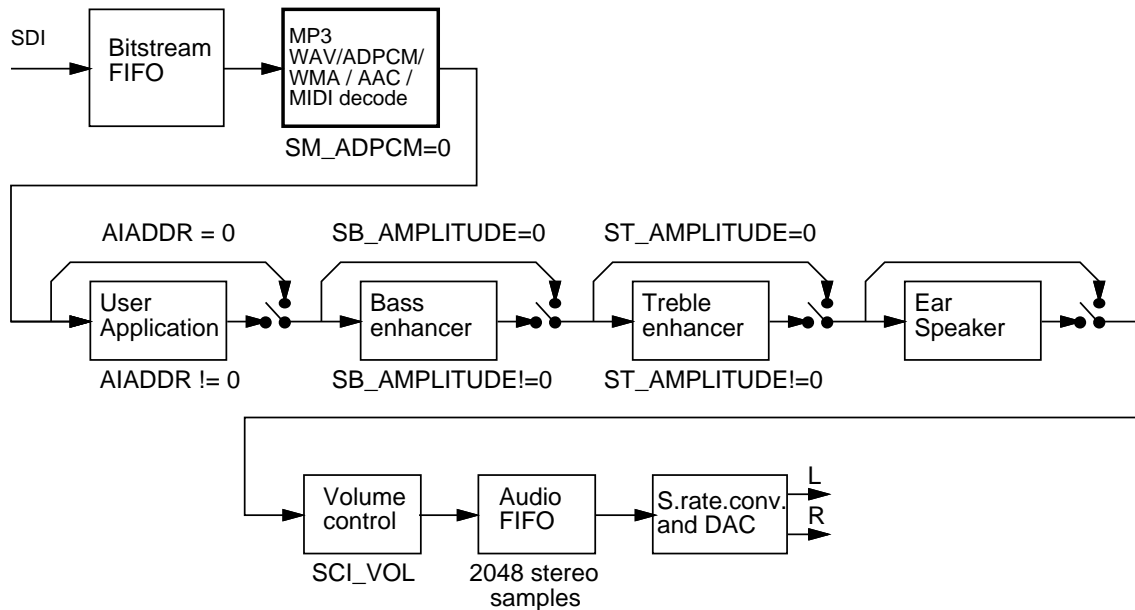

Figure 13: Data Flow of VS1033.

First, depending on the audio data, and provided ADPCM encoding mode is not set, MP3, WMA, AAC, PCM WAV, IMA ADPCM WAV, or MIDI data is received and decoded from the SDI bus.

After decoding, if SCI.AIADDR is non-zero, application code is executed from the address pointed to by that register. For more details, see Application Notes for VS10XX.

Then data may be sent to the Bass Enhancer and Treble Control depending on the SCI_BASS register.

Next, headphone processing is performed, if the EarSpeaker spatial processing is active.

After that the signal is fed to the volume control unit, which also copies the data to the Audio FIFO.

The Audio FIFO holds the data, which is read by the Audio interrupt (Chapter 10.14.1) and fed to the sample rate converter and DACs. The size of the audio FIFO is 2048 stereo (2×16-bit) samples, or 8 KiB.

The sample rate converter upsamples all different sample rates to XTALI/2, or 128 times the highest usable sample rate with 18-bit precision. This removes the need for complex PLL-based clocking schemes and allows almost unlimited sample rate accuracy with one fixed input clock frequency. With a 12.288 MHz clock, the DA converter operates at 128×48 kHz, i.e. 6.144 MHz, and creates a stereo in-phase analog signal. The oversampled output is low-pass filtered by an on-chip analog filter. This signal is then forwarded to the earphone amplifier.

8.4 EarSpeaker Spatial Processing

While listening to the headphones the sound has a tendency to be localized inside the head. The sound field becomes flat and lacking the sensation of dimensions. This is unnatural, awkward and sometimes even disturbing situation. This phenomenon is often referred in literature as 'lateralization', meaning 'in-the-head' localization. Long-term listening to lateralized sound may lead to listening fatigue.

All real-life sound sources are external, leaving traces to the acoustic wavefront that arrives to the ear drums. From these traces, the auditory system in the brain is able to judge the distance and angle of each sound source. In loudspeaker listening the sound is external and these traces are available. In headphone listening these traces are missing or ambiguous.

The EarSpeaker processing makes listening via headphones more like listening the same music from real loudspeakers or live music. Once the EarSpeaker processing is activated, the instruments are moved from inside to the outside of the head, making it easier to separate the different instruments (see figure 14). The listening experience becomes more natural and pleasant, and the stereo image is sharper as the instruments are widely on front of the listener instead of being inside the head.

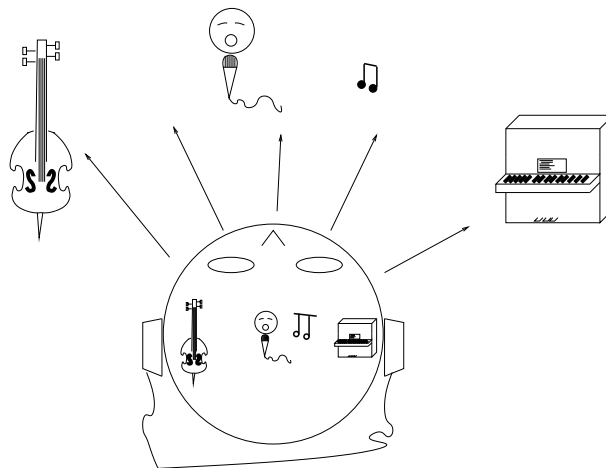

Figure 14: EarSpeaker externalized sound sources vs. normal inside-the-head sound

Note that EarSpeaker differs from any common spatial processing effects, such as echo, reverb, or bass boost. EarSpeaker simulates accurately human auditory model and real listening environment acoustics. Thus it does not change the tonal character of the music by introducing artificial effects.

EarSpeaker processing can be parameterized to a few different modes, each simulating a little different type of acoustical situation and suiting for different personal preference and type of recording. See section 8.7.1 for how to activate different modes.

- *Off*: Best option when listening through loudspeakers or if the audio to be played contains binaural preprocessing
- *minimal*: Suits well for listening to normal musical scores with headphones, very subtle
- *normal*: Suits well for listening to normal musical scores with headphones, moves sound source farther than *minimal*
- *extreme*: Suits well for old or 'dry' recordings, or if the audio to be played is artificial, for example generated MIDI

8.5 Serial Data Interface (SDI)

The serial data interface is meant for transferring compressed MP3, WMA, or AAC data, WAV PCM and ADPCM data as well as MIDI data.

If the input of the decoder is invalid or it is not received fast enough, analog outputs are automatically muted.

Also several different tests may be activated through SDI as described in Chapter 9.

8.6 Serial Control Interface (SCI)

The serial control interface is compatible with the SPI bus specification. Data transfers are always 16 bits. VS1033 is controlled by writing and reading the registers of the interface.

The main controls of the control interface are:

- control of the operation mode, clock, and builtin effects
- access to status information and header data
- access to encoded digital data
- uploading user programs

8.7 SCI Registers

VS1033 sets DREQ low when it detects an SCI operation and restores it when it has processed the operation. The duration depends on the operation. If DREQ is low when an SCI operation is performed, it also stays low after SCI operation processing.

If DREQ is high before a SCI operation, do not start a new SCI/SDI operation before DREQ is high again. If DREQ is low before a SCI operation because the SDI can not accept more data, make certain there is enough time to complete the operation before sending another.

SCI registers, prefix SCI_					
Reg	Type	Reset	Time ¹	Abbrev[bits]	Description
0x0	rw	0x800	70 CLKI ⁴	MODE	Mode control
0x1	rw	0x0C ³	40 CLKI	STATUS	Status of VS1033
0x2	rw	0	2100 CLKI	BASS	Built-in bass/treble enhancer
0x3	rw	0	11000 XTALI ⁵	CLOCKF	Clock freq + multiplier
0x4	rw	0	40 CLKI	DECODE_TIME	Decode time in seconds
0x5	rw	0	3200 CLKI	AUDATA	Misc. audio data
0x6	rw	0	80 CLKI	WRAM	RAM write/read
0x7	rw	0	80 CLKI	WRAMADDR	Base address for RAM write/read
0x8	r	0	-	HDATA0	Stream header data 0
0x9	r	0	-	HDATA1	Stream header data 1
0xA	rw	0	3200 CLKI ²	AIADDR	Start address of application
0xB	rw	0	2100 CLKI	VOL	Volume control
0xC	rw	0	50 CLKI ²	AICTRL0	Application control register 0
0xD	rw	0	50 CLKI ²	AICTRL1	Application control register 1
0xE	rw	0	50 CLKI ²	AICTRL2	Application control register 2
0xF	rw	0	50 CLKI ²	AICTRL3	Application control register 3

¹ This is the worst-case time that DREQ stays low after writing to this register. The user may choose to skip the DREQ check for those register writes that take less than 100 clock cycles to execute.

² In addition, the cycles spent in the user application routine must be counted.

³ Firmware changes the value of this register immediately to 0x58, and in less than 100 ms to 0x50.

⁴ When mode register write specifies a software reset the worst-case time is 20000 XTALI cycles.

⁵ Writing to this register may force internal clock to run at $1.0 \times XTALI$ for a while. Thus it is not a good idea to send SCI or SDI bits while this register update is in progress.

8.7.1 SCI_MODE (RW)

SCI_MODE is used to control the operation of VS1033 and defaults to 0x0800 (SM_SDINEW set).

Bit	Name	Function	Value	Description
0	SM_DIFF	Differential	0	normal in-phase audio
			1	left channel inverted
1	SM_LAYER12	Allow MPEG layers I & II	0	no
			1	yes
2	SM_RESET	Soft reset	0	no reset
			1	reset
3	SM_OUTOFWAV	Jump out of WAV decoding	0	no
			1	yes
4	SM_EARSPEAKER_LO	EarSpeaker low setting	0	off
			1	active
5	SM_TESTS	Allow SDI tests	0	not allowed
			1	allowed
6	SM_STREAM	Stream mode	0	no
			1	yes
7	SM_EARSPEAKER_HI	EarSpeaker high setting	0	off
			1	active
8	SM_DACT	DCLK active edge	0	rising
			1	falling
9	SM_SDIORD	SDI bit order	0	MSb first
			1	MSb last
10	SM_SDISHARE	Share SPI chip select	0	no
			1	yes
11	SM_SDINEW	VS1002 native SPI modes	0	no
			1	yes
12	SM_ADPCM	ADPCM recording active	0	no
			1	yes
13	SM_ADPCM_HP	ADPCM high-pass filter active	0	no
			1	yes
14	SM_LINE_IN	ADPCM recording selector	0	microphone
			1	line in
15	SM_CLK_RANGE	Input clock range	0	12..13 MHz
			1	24..26 MHz

When SM_DIFF is set, the player inverts the left channel output. For a stereo input this creates virtual surround, and for a mono input this creates a differential left/right signal.

SM_LAYER12 enables MPEG 1.0 and 2.0 layer I and II decoding in addition to layer III. **If you enable Layer I and Layer II decoding, you are liable for any patent issues that may arise.** Joint licensing of MPEG 1.0 / 2.0 Layer III does not cover all patents pertaining to layers I and II.

Software reset is initiated by setting SM_RESET to 1. This bit is cleared automatically.

If you want to stop decoding a WAV, WMA, or MIDI file in the middle, set SM_OUTOFWAV, and send data honouring DREQ until SM_OUTOFWAV is cleared. SCI_HDAT1 will also be cleared. For WMA and MIDI it is safest to continue sending the stream, send zeroes for WAV.

Bits SM_EARSPEAKER_LO and SM_EARSPEAKER_HI control the EarSpeaker spatial processing. If both are 0, the processing is not active. Other combinations activate the processing and select 3 different effect levels: LO = 1, HI = 0 selects *minimal*, LO = 0, HI = 1 selects *normal*, and LO = 1, HI = 1 selects *extreme*. EarSpeaker takes approximately 12 MIPS at 44.1 kHz sample rate. EarSpeaker is automatically disabled with AAC files.

If SM_TESTS is set, SDI tests are allowed. For more details on SDI tests, look at Chapter 9.10.

SM_STREAM activates VS1033's stream mode. In this mode, data should be sent with as even intervals as possible and preferable in blocks of less than 512 bytes, and VS1033 makes every attempt to keep its input buffer half full by changing its playback speed up to 5%. For best quality sound, the average speed error should be within 0.5%, the bitrate should not exceed 160 kbit/s and VBR should not be used. For details, see Application Notes for VS10XX. This mode only works with MP3 and WAV files.

SM_DACT defines the active edge of data clock for SDI. When '0', data is read at the rising edge, when '1', data is read at the falling edge.

When SM_SDIORD is clear, bytes on SDI are sent MSb first. By setting SM_SDIORD, the user may reverse the bit order for SDI, i.e. bit 0 is received first and bit 7 last. Bytes are, however, still sent in the default order. This register bit has no effect on the SCI bus.

Setting SM_SDISHARE makes SCI and SDI share the same chip select, as explained in Chapter 7.2, if also SM_SDINEW is set.

Setting SM_SDINEW will activate VS1002 native serial modes as described in Chapters 7.2.1 and 7.4.2. Note, that this bit is set as a default when VS1033 is started up.

By activating SM_ADPCM and SM_RESET at the same time, the user will activate IMA ADPCM recording mode (see section 9.4). If SM_ADPCM_HP is set (use only for 8 kHz sample rate), ADPCM mode will start with a high-pass filter. This may help intelligibility of speech when there is lots of background noise. The difference created to the ADPCM encoder frequency response is as shown in Figure 15.

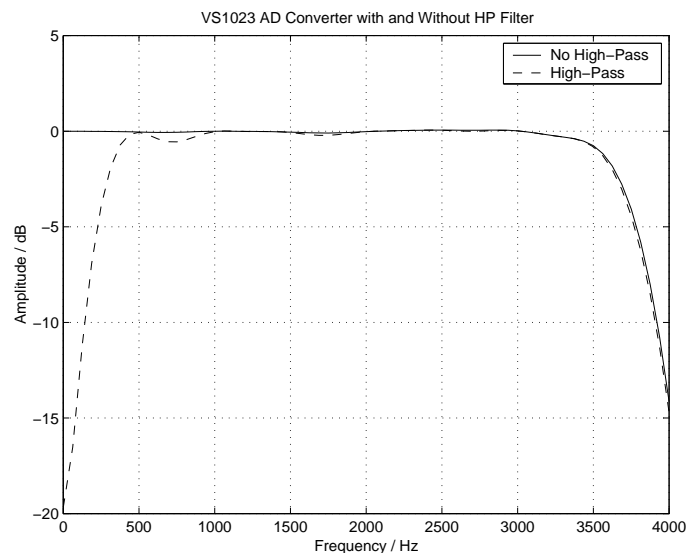

Figure 15: ADPCM Frequency Responses with 8 kHz sample rate.

SM_LINE_IN is used to select the input for ADPCM recording. If '0', microphone input pins MICP and MICN are used; if '1', LINEIN is used.

SM_CLK_RANGE activates a clock divider in the XTAL input. When SM_CLK_RANGE is set, from the chip's point of view e.g. 24 MHz becomes 12 MHz. When used, SM_CLK_RANGE should be set as soon as possible after a chip reset.

8.7.2 SCI_STATUS (RW)

SCI_STATUS contains information on the current status of VS1033.

Name	Bits	Description
SS_VER	6:4	Version
SS_APDOWN2	3	Analog driver powerdown
SS_APDOWN1	2	Analog internal powerdown
SS_AVOL	1:0	Analog volume control

SS_VER is 0 for VS1001, 1 for VS1011, 2 for VS1002, 3 for VS1003, 4 for VS1053, 5 for VS1033, 7 for VS1103.

SS_APDOWN2 controls analog driver powerdown. SS_APDOWN1 controls internal analog powerdown. These bits are meant to be used by the system firmware only. Use SCI_VOL to control the analog driver powerdown.

SS_AVOL is the analog volume control: 0 = -0 dB, 1 = -6 dB, 3 = -12 dB. This register is meant to be used automatically by the system firmware only.

8.7.3 SCI_BASS (RW)

Name	Bits	Description
ST_AMPLITUDE	15:12	Treble Control in 1.5 dB steps (-8..7, 0 = off)
ST_FREQLIMIT	11:8	Lower limit frequency in 1000 Hz steps (1..15)
SB_AMPLITUDE	7:4	Bass Enhancement in 1 dB steps (0..15, 0 = off)
SB_FREQLIMIT	3:0	Lower limit frequency in 10 Hz steps (2..15)

The Bass Enhancer VSBE is a powerful bass boosting DSP algorithm, which tries to take the most out of the users earphones without causing clipping.

VSBE is activated when SB_AMPLITUDE is non-zero. SB_AMPLITUDE should be set to the user's preferences, and SB_FREQLIMIT to roughly 1.5 times the lowest frequency the user's audio system can reproduce. For example setting SCI_BASS to 0x00f6 will have 15 dB enhancement below 60 Hz.

Note: Because VSBE tries to avoid clipping, it gives the best bass boost with dynamical music material, or when the playback volume is not set to maximum. It also does not create bass: the source material must have some bass to begin with.

Treble Control VSTC is activated when ST_AMPLITUDE is non-zero. For example setting SCI_BASS to 0x7a00 will have 10.5 dB treble enhancement at and above 10 kHz.

Bass Enhancer uses about 2.1 MIPS and Treble Control 1.2 MIPS at 44100 Hz sample rate. Both can be on simultaneously.

8.7.4 SCI_CLOCKF (RW)

The operation of SCI_CLOCKF is different in VS1003 and VS1033 than in VS10x1 and VS1002. For general applications with 12.288 MHz clock use 0x9000 for $3.0 \times ..4.0\times$, or 0xa800 for $3.5 \times ..4.0\times$.

SCI_CLOCKF bits		
Name	Bits	Description
SC_MULT	15:13	Clock multiplier
SC_ADD	12:11	Allowed multiplier addition
SC_FREQ	10: 0	Clock frequency

SC_MULT activates the built-in clock multiplier. This will multiply XTALI to create a higher CLKI. The values are as follows:

SC_MULT	MASK	CLKI
0	0x0000	XTALI
1	0x2000	XTALI×1.5
2	0x4000	XTALI×2.0
3	0x6000	XTALI×2.5
4	0x8000	XTALI×3.0
5	0xa000	XTALI×3.5
6	0xc000	XTALI×4.0
7	0xe000	XTALI×4.5

SC_ADD tells, how much the decoder firmware is allowed to add to the multiplier specified by SC_MULT if more cycles are temporarily needed to decode a WMA stream. The values are:

SC_ADD	MASK	Multiplier addition
0	0x0000	No modification is allowed
1	0x0800	0.5×
2	0x1000	1.0×
3	0x1800	1.5×

SC_FREQ is used to tell if the input clock XTALI is running at something else than 12.288 MHz. XTALI is set in 4 kHz steps. The formula for calculating the correct value for this register is $\frac{XTALI-8000000}{4000}$ (XTALI is in Hz).

Note: The default value 0 is assumed to mean XTALI=12.288 MHz.

Note: because maximum sample rate is $\frac{XTALI}{256}$, all sample rates are not available if XTALI < 12.288 MHz.

Note: Automatic clock change can only happen when decoding WMA files. Automatic clock change is done one 0.5× at a time. This does not cause a drop to 1.0× clock and you can use the same SCI and SDI clock throughout the WMA file.

Example: If SCI_CLOCKF is 0x9BE8, SC_MULT = 4, SC_ADD = 3 and SC_FREQ = 0x3E8 = 1000. This means that XTALI = $1000 \times 4000 + 8000000 = 12$ MHz. The clock multiplier is set to $3.0 \times XTALI = 36$ MHz, and the maximum allowed multiplier that the firmware may automatically choose to use is $(3.0 + 1.5) \times XTALI = 54$ MHz.

8.7.5 SCI_DECODE_TIME (RW)

When decoding correct data, current decoded time is shown in this register in full seconds.

The user may change the value of this register. In that case the new value should be written twice.

SCI_DECODE_TIME is reset at every software reset and also when WAV (PCM or IMA ADPCM), AAC, WMA, or MIDI decoding starts or ends.

8.7.6 SCI_AUDATA (RW)

When decoding correct data, the current sample rate and number of channels can be found in bits 15:1 and 0 of SCI_AUDATA, respectively. Bits 15:1 contain the sample rate divided by two, and bit 0 is 0 for mono data and 1 for stereo. Writing to SCI_AUDATA will change the sample rate directly.

Example: 44100 Hz stereo data reads as 0xAC45 (44101).

Example: 11025 Hz mono data reads as 0x2B10 (11024).

Example: Writing 0xAC80 sets sample rate to 44160 Hz, stereo mode does not change.

To reduce the digital power consumption when in idle, you can write a low samplerate to SCI_AUDATA, and also write 0 to SCI_CLOCKF to turn off the PLL.

8.7.7 SCI_WRAM (RW)

SCI_WRAM is used to upload application programs and data to instruction and data RAMs. The start address must be initialized by writing to SCI_WRAMADDR prior to the first write/read of SCI_WRAM. As 16 bits of data can be transferred with one SCI_WRAM write/read, and the instruction word is 32 bits long, two consecutive writes/reads are needed for each instruction word. The byte order is big-endian (i.e. most significant words first). After each full-word write/read, the internal pointer is autoincremented.

8.7.8 SCI_WRAMADDR (W)

SCI_WRAMADDR is used to set the program address for following SCI_WRAM writes/reads. Address offset of 0 is used for X, 0x4000 for Y, and 0x8000 for instruction memory. Peripheral registers can also be accessed.

SM_WRAMADDR Start... End	Dest. addr. Start... End	Bits/ Word	Description
0x1800...0x187F	0x1800...0x187F	16	X data RAM
0x5800...0x587F	0x1800...0x187F	16	Y data RAM
0x8030...0x84FF	0x0030...0x04FF	32	Instruction RAM
0xC000...0xFFFF	0xC000...0xFFFF	16	I/O

Only user areas in X, Y, and instruction memory are listed above. Other areas can be accessed, but should not be written to unless otherwise specified.

8.7.9 SCI_HDAT0 and SCI_HDAT1 (R)

For WAV files, SCI_HDAT1 contains 0x7665 (“ve”). SCI_HDAT0 contains the data rate in double word increments for all supported RIFF WAVE formats: mono and stereo 8-bit or 16-bit PCM, mono and stereo IMA ADPCM. To get the byte rate of the file, multiply the value by 4. To get the bit rate of the file, multiply the value by 32. *Note: usage of SCI_HDAT0 with WAV files has changed from VS1003.*

For AAC ADTS streams, SCI_HDAT1 contains 0x4154 (“AT”). For AAC ADIF files, SCI_HDAT1 contains 0x4144 (“AD”). For AAC .mp4 / .m4a files, SCI_HDAT1 contains 0x4D34 (“M4”). SCI_HDAT0 contains the average data rate in bytes per second. To get the bit rate of the file, multiply the value by 8.

For WMA files, SCI_HDAT1 contains 0x574D (“WM”) and SCI_HDAT0 contains the data rate measured in bytes per second. To get the bit rate of the file, multiply the value by 8.

for MIDI files, SCI_HDAT1 contains 0x4D54 (“MT”) and SCI_HDAT0 contains the average data rate in bytes per second. To get the bit rate of the file, multiply the value by 8. *Note: usage of SCI_HDAT0 with MIDI has changed from VS1003.*

For MP3 files, SCI_HDAT1 is between 0xFFE0 and 0xFFFF. SCI_HDAT1 / 0 contain the following:

Bit	Function	Value	Explanation
HDAT1[15:5]	syncword	2047	stream valid
HDAT1[4:3]	ID	3	ISO 11172-3 MPG 1.0
		2	ISO 13818-3 MPG 2.0 (1/2-rate)
		1	MPG 2.5 (1/4-rate)
		0	MPG 2.5 (1/4-rate)
HDAT1[2:1]	layer	3	I
		2	II
		1	III
		0	reserved
HDAT1[0]	protect bit	1	No CRC
		0	CRC protected
HDAT0[15:12]	bitrate		see bitrate table
HDAT0[11:10]	sample rate	3	reserved
		2	32/16/ 8 kHz
		1	48/24/12 kHz
		0	44/22/11 kHz
HDAT0[9]	pad bit	1	additional slot
		0	normal frame
HDAT0[8]	private bit		not defined
HDAT0[7:6]	mode	3	mono
		2	dual channel
		1	joint stereo
		0	stereo
HDAT0[5:4]	extension		see ISO 11172-3
HDAT0[3]	copyright	1	copyrighted
		0	free
HDAT0[2]	original	1	original
		0	copy
HDAT0[1:0]	emphasis	3	CCITT J.17
		2	reserved
		1	50/15 microsec
		0	none

When read, SCI_HDAT0 and SCI_HDAT1 contain header information that is extracted from MP3 stream currently being decoded. After reset both registers are cleared, indicating no data has been found yet.

The “sample rate” field in SCI_HDAT0 is interpreted according to the following table:

“sample rate”	ID=3	ID=2	ID=0,1
3	-	-	-
2	32000	16000	8000
1	48000	24000	12000
0	44100	22050	11025

The “bitrate” field in HDAT0 is read according to the following table. Notice that for variable bitrate stream the value changes constantly.

“bitrate”	Layer I		Layer II		Layer III	
	ID=3	ID=0,1,2	ID=3	ID=0,1,2	ID=3	ID=0,1,2
	kbit/s		kbit/s		kbit/s	
15	forbidden	forbidden	forbidden	forbidden	forbidden	forbidden
14	448	256	384	160	320	160
13	416	224	320	144	256	144
12	384	192	256	128	224	128
11	352	176	224	112	192	112
10	320	160	192	96	160	96
9	288	144	160	80	128	80
8	256	128	128	64	112	64
7	224	112	112	56	96	56
6	192	96	96	48	80	48
5	160	80	80	40	64	40
4	128	64	64	32	56	32
3	96	56	56	24	48	24
2	64	48	48	16	40	16
1	32	32	32	8	32	8
0	-	-	-	-	-	-

8.7.10 SCI_AIADDR (RW)

SCI_AIADDR indicates the start address of the application code written earlier with SCI_WRAMADDR and SCI_WRAM registers. If no application code is used, this register should not be initialized, or it should be initialized to zero. For more details, see Application Notes for VS10XX.

8.7.11 SCI_VOL (RW)

SCI_VOL is a volume control for the player hardware. The most significant byte of the volume register controls the left channel volume, the low part controls the right channel volume. The channel volume

sets the attenuation from the maximum volume level in 0.5 dB steps. Thus, maximum volume is 0x0000 and total silence is 0xFEFE.

Note, that after hardware reset the volume is set to full volume. Resetting the software does not reset the volume setting.

Setting SCI_VOL to 0xFFFF will activate analog powerdown mode.

Example: for a volume of -2.0 dB for the left channel and -3.5 dB for the right channel: $(2.0/0.5) = 4$, $3.5/0.5 = 7 \rightarrow \text{SCI_VOL} = 0x0407$.

Example: $\text{SCI_VOL} = 0x2424 \rightarrow$ both left and right volumes are $0x24 * -0.5 = -18.0 \text{ dB}$

8.7.12 SCLAICTRL[x] (RW)

SCLAICTRL[x] registers ($x=[0 .. 3]$) can be used to communicate with the user's application program. They are also used in the ADPCM recording mode.

9 Operation

9.1 Clocking

VS1033 operates on a single, nominally 12.288 MHz fundamental frequency master clock. This clock can be generated by external circuitry (connected to pin XTALI) or by the internal clock crystal interface (pins XTALI and XTALO).

VS1033 can also use 24..26 MHz clocks when SM_CLK_RANGE is set to 1. From the chip's point of view the input clock is then 12..13 MHz.

9.2 Hardware Reset

When the XRESET -signal is driven low, VS1033 is reset and all the control registers and internal states are set to the initial values. XRESET-signal is asynchronous to any external clock. The reset mode doubles as a full-powerdown mode, where both digital and analog parts of VS1033 are in minimum power consumption stage, and where clocks are stopped. Also XTALO is grounded.

When XRESET is asserted, all output pins go to their default states. All input pins will go to high-impedance state (to input state), except SO, which is still controlled by the XCS.

After a hardware reset (or at power-up) DREQ will stay down for around 20000 clock cycles, which means an approximate 1.6 ms delay if VS1033 is run at 12.288 MHz. After this the user should set such basic software registers as SCI_MODE, SCI_BASS, SCI_CLOCKF, and SCI_VOL before starting decoding. See section 8.7 for details.

If the input clock is 24..26 MHz, SM_CLK_RANGE should be set as soon as possible after a chip reset without waiting for DREQ.

Internal clock can be multiplied with a PLL. Supported multipliers through the SCI_CLOCKF register are $1.0 \times \dots 4.5 \times$ the input clock. Reset value for Internal Clock Multiplier is $1.0 \times$. If typical values are wanted, the Internal Clock Multiplier needs to be set to $3.0 \times$ after reset. Wait until DREQ rises, then write value 0x9800 to SCI_CLOCKF (register 3). See section 8.7.4 for details.

9.3 Software Reset

In some cases the decoder software has to be reset. This is done by activating bit 2 in `SCI_MODE` register (Chapter 8.7.1). Then wait for at least $2 \mu s$, then look at `DREQ`. `DREQ` will stay down for at least 20000 clock cycles, which means an approximate 1.6 ms delay if VS1033 is run at 12.288 MHz. After `DREQ` is up, you may continue playback as usual.

If you want to make sure VS1033 doesn't cut the ending of low-bitrate data streams and you want to do a software reset, it is recommended to feed 2052 zeros (honoring `DREQ`) to the SDI bus after the file and before the reset. This is especially important for MIDI files.

If you want to interrupt the playing of a WAV, AAC, WMA, or MIDI file in the middle, set `SM_OUTOFWAV` in the mode register, and send data honouring `DREQ` (with a three-second timeout) until `SM_OUTOFWAV` is cleared (`SCI_HDAT1` will also be cleared) before continuing with a software reset. For WMA and MIDI it is safest to continue sending the stream, send zeroes for WAV.

9.4 ADPCM Recording

This chapter explains how to create RIFF/WAV file with IMA ADPCM format. This is a widely supported ADPCM format and many PC audio playback programs can play it. IMA ADPCM recording gives roughly a compression ratio of 4:1 compared to linear, 16-bit audio. This makes it possible to record 8 kHz audio at 32.44 kbit/s.

9.4.1 Activating ADPCM mode

IMA ADPCM recording mode is activated by setting bits SM_RESET and SM_ADPCM in SCI_MODE. Optionally a high-pass-filter can be enabled for 8 kHz sample rate by also setting SM_ADPCM_HP at the same time. Line input is used instead of mic if SM_LINE_IN is set. Before activating ADPCM recording, user **must** write a clock divider value to SCLAICTRL0 and gain to SCLAICTRL1.

The differences of using SM_ADPCM_HP are presented in figure 15 (page 37). As a general rule, audio will be fuller and closer to original if SM_ADPCM_HP is not used. However, speech may be more intelligible with the high-pass filter active. Use the filter only with 8 kHz sample rate.

Before activating ADPCM recording, user should write a clock divider value to SCLAICTRL0. The sampling frequency is calculated from the following formula: $f_s = \frac{F_c}{256 \times d}$, where F_c is the internal clock (CLKI) and d is the divider value in SCLAICTRL0. If the sample rate is < 16000 Hz, additional software decimation by two is performed and the lowest valid value for d is 4, otherwise the lowest valid value for d is 2. If SCLAICTRL0 contains 0, the default divider value 12 is used.

Examples:

$$F_c = 2.0 \times 12.288 \text{ MHz}, d = 12. \text{ Now } f_s = \frac{2.0 \times 12288000}{256 \times 12} = 8000 \text{ Hz.}$$
$$F_c = 2.5 \times 14.745 \text{ MHz}, d = 18. \text{ Now } f_s = \frac{2.5 \times 14745000}{256 \times 18} = 8000 \text{ Hz.}$$
$$F_c = 2.5 \times 13 \text{ MHz}, d = 16. \text{ Now } f_s = \frac{2.5 \times 13000000}{256 \times 16} = 7935 \text{ Hz.}$$

Also, before activating ADPCM mode, the user has to set linear recording gain control to register SCLAICTRL1. 1024 is equal to digital gain 1, 512 is equal to digital gain 0.5 and so on. If the user wants to use automatic gain control (AGC), SCLAICTRL1 should be set to 0. Typical speech applications usually are better off using AGC, as this takes care of relatively uniform speech loudness in recordings.

Since VS1033c SCLAICTRL2 controls the maximum AGC gain. If SCLAICTRL2 is zero, the maximum gain is 65535 (64×), i.e. whole range is used. This is compatible with previous operation.

9.4.2 Reading IMA ADPCM Data

After IMA ADPCM recording has been activated, registers SCLHDAT0 and SCLHDAT1 have new functions.

The IMA ADPCM sample buffer is 1024 16-bit words. The fill status of the buffer can be read from SCLHDAT1. If SCLHDAT1 is greater than 0, you can read as many 16-bit words from SCLHDAT0. If the data is not read fast enough, the buffer overflows and returns to empty state.

Note: if $SCLHDAT1 \geq 896$, it may be better to wait for the buffer to overflow and clear before reading samples. That way you may avoid buffer aliasing.

Each IMA ADPCM block is 128 words, i.e. 256 bytes. If you wish to interrupt reading data and possibly continue later, please stop at a 128-word boundary. This way whole blocks are skipped and the encoded stream stays valid.

9.4.3 Adding a RIFF Header

To make your IMA ADPCM file a RIFF / WAV file, you have to add a header before the actual data. Note that 2- and 4-byte values are little-endian (lowest byte first) in this format:

File Offset	Field Name	Size	Bytes	Description
0	ChunkID	4	"RIFF "	
4	ChunkSize	4	F0 F1 F2 F3	File size - 8
8	Format	4	"WAVE "	
12	SubChunk1ID	4	"fmt "	
16	SubChunk1Size	4	0x14 0x0 0x0 0x0	20
20	AudioFormat	2	0x11 0x0	0x11 for IMA ADPCM
22	NumOfChannels	2	0x1 0x0	Mono sound
24	SampleRate	4	R0 R1 R2 R3	0x1f40 for 8 kHz
28	ByteRate	4	B0 B1 B2 B3	0xfd7 for 8 kHz
32	BlockAlign	2	0x0 0x1	0x100
34	BitsPerSample	2	0x4 0x0	4-bit ADPCM
36	ByteExtraData	2	0x2 0x0	2
38	ExtraData	2	0xf9 0x1	Samples per block (505)
40	SubChunk2ID	4	"fact "	
44	SubChunk2Size	4	0x4 0x0 0x0 0x0	4
48	NumOfSamples	4	S0 S1 S2 S3	
52	SubChunk3ID	4	"data "	
56	SubChunk3Size	4	D0 D1 D2 D3	Data size (File Size-60)
60	Block1	256		First ADPCM block
316	...			More ADPCM data blocks

If we have n audio blocks, the values in the table are as follows:

$$F = n \times 256 + 52$$

$$R = F_s \text{ (see Chapter 9.4.1 to see how to calculate } F_s)$$

$$B = \frac{F_s \times 256}{505}$$

$$S = n \times 505. D = n \times 256$$

If you know beforehand how much you are going to record, you may fill in the complete header before any actual data. However, if you don't know how much you are going to record, you have to fill in the header size datas F , S and D after finishing recording.

The 128 words (256 bytes) of an ADPCM block are read from SCI_HDAT0 and written into file as follows. The high 8 bits of SCI_HDAT0 should be written as the first byte to a file, then the low 8 bits. Note that this is contrary to the default operation of some 16-bit microcontrollers, and you may have to take extra care to do this right.

A way to see if you have written the file in the right way is to check bytes 2 and 3 (the first byte counts as byte 0) of each 256-byte block. Byte 3 should always be zero.

9.4.4 Playing ADPCM Data

In order to play back your IMA ADPCM recordings, you have to have a file with a header as described in Chapter 9.4.3. If this is the case, all you need to do is to provide the ADPCM file through SDI as you would with any audio file.

9.4.5 Sample Rate Considerations

VS10xx chips that support IMA ADPCM playback are capable of playing back ADPCM files with any sample rate. However, some other programs may expect IMA ADPCM files to have some exact sample rates, like 8000 or 11025 Hz. Also, some programs or systems do not support sample rates below 8000 Hz.

However, if you don't have an appropriate clock, you may not be able to get an exact 8 kHz sample rate. If you have a 12 MHz clock, the closest sample rate you can get with $2.0 \times 12 \text{ MHz}$ and $d = 12$ is $f_s = 7812.5 \text{ Hz}$. Because the frequency error is only 2.4%, it may be best to set $f_s = 8000 \text{ Hz}$ to the header if the same file is also to be played back with a PC. This causes the sample to be played back a little faster (one minute is played in 59 seconds).

Note, however, that unless absolutely necessary, sample rates should not be tweaked in the way described here. If you want better quality with the expense of increased data rate, you can use higher sample rates, for example 16 kHz.

9.4.6 AD Startup Time

Depending on the external components it may take 2-5 seconds for the MIC and LINE bias to wake up properly. You can reduce the settling time by changing the components. You can also speed up the process by enabling the AD with a low sample rate some time before the recording starts by writing 0xc01e to SCLWRAMADDR, then 0x0800 to SCLWRAM. Notice that hardware and software reset disables the AD.

9.4.7 Example Code

The following code initializes IMA ADPCM encoding on VS1033 and shows how to read the data.

```
const unsigned char header[] = {
    0x52, 0x49, 0x46, 0x46, 0x1c, 0x10, 0x00, 0x00,
    0x57, 0x41, 0x56, 0x45, 0x66, 0x6d, 0x74, 0x20, /*|RIFF....WAVEfmt |*/
    0x14, 0x00, 0x00, 0x00, 0x11, 0x00, 0x01, 0x00,
    0x40, 0x1f, 0x00, 0x00, 0x75, 0x12, 0x00, 0x00, /*|.....@.....|*/
    0x00, 0x01, 0x04, 0x00, 0x02, 0x00, 0xf9, 0x01,
    0x66, 0x61, 0x63, 0x74, 0x04, 0x00, 0x00, 0x00, /*|.....fact....|*/
    0x5c, 0x1f, 0x00, 0x00, 0x64, 0x61, 0x74, 0x61,
    0xe8, 0x0f, 0x00, 0x00
};
```

```
unsigned char db[512]; /* data buffer for saving to disk */

void RecordAdpcm1003(void) { /* VS1003b/VS1033c */
    u_int16 w = 0, idx = 0;

    ... /* Check and locate free space on disk */

    SetMp3Vol(0x1414); /* Recording monitor volume */
    WriteMp3SpiReg(SCI_BASS, 0); /* Bass/treble disabled */

    WriteMp3SpiReg(SCI_CLOCKF, 0x4430); /* 2.0x 12.288MHz */
    Wait(100);
    WriteMp3SpiReg(SCI_AICTRL0, 12); /* Div -> 12=8kHz 8=12kHz 6=16kHz */
    Wait(100);
    WriteMp3SpiReg(SCI_AICTRL1, 0); /* Auto gain */
    Wait(100);
    if (line_in) {
        WriteMp3SpiReg(SCI_MODE, 0x5804); /* Normal SW reset + other bits */
    } else {
        WriteMp3SpiReg(SCI_MODE, 0x1804); /* Normal SW reset + other bits */
    }
    for (idx=0; idx < sizeof(header); idx++) { /* Save header first */
        db[idx] = header[idx];
    }
    /* Fix rate if needed */
    /*db[24] = rate;*/
    /*db[25] = rate>>8;*/

    /* Record loop */
    while (recording_on) {
        do {
            w = ReadMp3SpiReg(SCI_HDAT1);
        } while (w < 256 || w >= 896); /* wait until 512 bytes available */

        while (idx < 512) {
            w = ReadMp3SpiReg(SCI_HDAT0);
            db[idx++] = w>>8;
            db[idx++] = w&0xFF;
        }
        idx = 0;
        write_block(datasector++, db); /* Write output block to disk */
    }
    ... /* Fix WAV header information */
    ... /* Then update FAT information */
    ResetMP3(); /* Normal reset, restore default settings */
    SetMp3Vol(vol);
}
}
```

9.5 SPI Boot

If GPIO0 is set with a pull-up resistor to 1 at boot time, VS1033 tries to boot from external SPI memory.

SPI boot redefines the following pins:

Normal Mode	SPI Boot Mode
GPIO0	xCS
GPIO1	CLK
DREQ	MOSI
GPIO2	MISO

The memory has to be an SPI Bus Serial EEPROM with 16-bit addresses (i.e. at least 1 KiB). The serial speed used by VS1033 is 245 kHz with the nominal 12.288 MHz clock. The first three bytes in the memory have to be 0x50, 0x26, 0x48.

9.6 Play/Decode

This is the normal operation mode of VS1033. SDI data is decoded. Decoded samples are converted to analog domain by the internal DAC. If no decodable data is found, SCI_HDAT0 and SCI_HDAT1 are set to 0 and analog outputs are muted.

When there is no input for decoding, VS1033 goes into idle mode (lower power consumption than during decoding) and actively monitors the serial data input for valid data.

All different formats can be played back-to-back without software reset in-between. Send at least 2052 zeros after each stream. However, using software reset between streams may still be a good idea, as it guards against broken files. In this case you should wait for the completion of the decoding (SCI_HDAT1 and SCI_HDAT0 become zero) before issuing software reset.

9.7 Feeding PCM data

VS1033 can be used as a PCM decoder by sending a WAV file header. If the length sent for the WAV/DATA is 0xFFFFFFFF, VS1033 will stay in PCM mode indefinitely (or until SM_OUTOFWAV has been set). 8-bit linear and 16-bit linear audio is supported in mono or stereo. A WAV header looks like this:

File Offset	Field Name	Size	Bytes	Description
0	ChunkID	4	"RIFF"	
4	ChunkSize	4	0xff 0xff 0xff 0xff	
8	Format	4	"WAVE"	
12	SubChunk1ID	4	"fmt "	
16	SubChunk1Size	4	0x10 0x0 0x0 0x0	16
20	AudioFormat	2	0x1 0x0	Linear PCM
22	NumOfChannels	2	C0 C1	1 for mono, 2 for stereo
24	SampleRate	4	S0 S1 S2 S3	0x1f40 for 8 kHz
28	ByteRate	4	R0 R1 R2 R3	0x3e80 for 8 kHz 16-bit mono
32	BlockAlign	2	A0 A1	2 for mono, 4 for stereo 16-bit
34	BitsPerSample	2	B0 0xB1	16 for 16-bit data
52	SubChunk2ID	4	"data"	
56	SubChunk2Size	4	0xff 0xff 0xff 0xff	Data size

The rules to calculate the four variables are as follows:

- S = sample rate in Hz, e.g. 44100 for 44.1 kHz.
- For 8-bit data $B = 8$, and for 16-bit data $B = 16$.
- For mono data $C = 1$, for stereo data $C = 2$.
- $A = \frac{C \times B}{8}$.
- $R = S \times A$.

Example: A 44100 Hz 16-bit stereo PCM header would read as follows:

```

0000  52 49 46 46 ff ff ff ff  57 41 56 45 66 6d 74 20  |RIFF....WAVEfmt |
0100  10 00 00 00 01 00 02 00  44 ac 00 00 10 b1 02 00  |.....D.....|
0200  04 00 10 00 64 61 74 61  ff ff ff ff  |....data....|

```

9.8 Extra Parameters

The following structure is in X memory at address 0x1940 and can be used to change some extra parameters or get various information. The chip ID is also easily available.

```
#define PARAMETRIC_VERSION 0x0001
struct parametric {
    u_int32 chipID; /*1940/41 Initialized at reset for your convenience */
    u_int16 version; /*1942 - structure version */
    u_int16 midiConfig; /*1943 */
    u_int16 config1; /*1944 */
    u_int16 config2; /*1945 configs are not cleared between files */

    u_int32 jumpPoints[16]; /*1946..65 file byte offsets */
    u_int16 latestJump; /*1966 index to lastly updated jumpPoint */
    s_int16 seek1; /*1967 file data inserted/removed bytes -32768..32767*/
    s_int16 seek2; /*1968 file data inserted/removed kB -32768..32767*/
    s_int16 resync; /*1969 > 0 for automatic m4a, ADIF, WMA resyncs */
    union {
        struct {
            u_int32 curPacketSize;
            u_int32 packetSize;
        } wma;
        struct {
            u_int16 sceFoundMask; /* SCE's found since last clear */
            u_int16 cpeFoundMask; /* CPE's found since last clear */
            u_int16 lfeFoundMask; /* LFE's found since last clear */
            u_int16 playSelect; /* 0 = first any, initialized at aac init */
            s_int16 dynCompress; /* -8192=1.0, initialized at aac init */
            s_int16 dynBoost; /* 8192=1.0, initialized at aac init */
        } aac;
        struct {
            u_int32 bytesLeft;
        } midi;
    } i;
};
```

Notice that reading two-word variables through the SCI_WRAMADDR and SCI_WRAM interface is not protected in any way. The variable can be updated between the read of the low and high parts. The problem arises when both the low and high parts change values. To determine if the value is correct, you should read the value twice and compare the results.

The following example shows what happens when `bytesLeft` is decreased from 0x10000 to 0xffff and the update happens between low and high part reads or after high part read.

Read Invalid		Read Valid		No Update	
Address	Value	Address	Value	Address	Value
0x196a	0x0000 change after this	0x196a	0x0000	0x196a	0x0000
0x196b	0x0000	0x196b	0x0001 change after this	0x196b	0x0001
0x196a	0xffff	0x196a	0xffff	0x196a	0x0000
0x196b	0x0000	0x196b	0x0000	0x196b	0x0001

You can see that in the invalid read the low part wraps from 0x0000 to 0xffff while the high part stays the same. In this case the second read gives a valid answer, otherwise always use the value of the first read. The second read is needed when it is possible that the low part wraps around, changing the high part, i.e. when the low part is small. `bytesLeft` is only decreased by one at a time, so a reread is needed only if the low part is 0.

9.8.1 Common Parameters

Parameter	Address	Usage
chipID	0x1940/41	Fuse-programmed unique ID (copy)
version	0x1942	Structure version – 0x0001
jumpPoints[16]	0x1946-65	Packet offsets for WMA and AAC
latestJump	0x1966	Index to latest jumpPoint
seek1	0x1967	Seek amount in bytes
seek2	0x1968	Seek amount in kilobytes
resync	0x1969	Automatic resync selector

The fuse-programmed ID is read at startup and copied into the `chipID` field. The `version` field can be used to determine the layout of the rest of the structure. The version number is changed when the structure is changed.

`jumpPoints` contain 32-bit file offsets. Each valid (non-zero) entry indicates a start of a packet for WMA or start of a raw data block for AAC (ADIF, .mp4 / .m4a). `latestJump` contains the index of the entry that was updated last. If you only read entry pointed to by `latestJump` you do *not* need to read the entry twice to ensure validity. Jump point information can be used to implement perfect fast forward and rewind for WMA and AAC (ADIF, .mp4 / .m4a).

`seek1` and `seek2` fields are used when music data is skipped or inserted. Negative values mean that data has been added (for example in rewind operation), positive values mean that data has been skipped. You can use either `seek1`, which gives the seek amount in bytes, or `seek2` which gives the seek amount in kilobytes, or you can use both. The field value is zeroed when the firmware has detected the seek.

`resync` field is used to force a resynchronization to the stream for WMA and AAC (ADIF, .mp4 / .m4a). This field can be used to implement almost perfect fast forward and rewind for WMA and AAC (ADIF, .mp4 / .m4a). The user should set this field before performing data seeks if they are not in packet or data block boundaries. The field value tells how many tries are allowed before giving up. The value 32767 gives infinite tries, in which case the user must use `SM_OUTOFWAV` or software reset to end decoding. In every case remember to use `seek1` and/or `seek2` fields to indicate the skipped/inserted data.

Note: WMA, ADIF, and .mp4 / .m4a files begin with a metadata section, which must be fully processed before any fast forward or rewind operation. When the first `jumpPoint` appears it is safe to perform seeks. You can also detect the start of decoding from `SCI_DECODE_TIME`.

9.8.2 WMA

Parameter	Address	Usage
curPacketSize	0x196a/6b	The size of the packet being processed
packetSize	0x196c/6d	The packet size in ASF header

The ASF header packet size is available in `packetSize`. With this information and a packet start offset from `jumpPoints` you can parse the packet headers and skip packets in ASF files.

9.8.3 AAC

Parameter	Address	Usage
sceFoundMask	0x196a	Single channel elements found
cpeFoundMask	0x196b	Channel pair elements found
lfeFoundMask	0x196c	Low frequency elements found
playSelect	0x196d	Play element selection
dynCompress	0x196e	Compress coefficient for DRC, -8192=1.0
dynBoost	0x196f	Boost coefficient for DRC, 8192=1.0

`playSelect` determines which element to decode if a stream has multiple elements. The value is set to 0 each time AAC decoding starts, which causes the first element that appears in the stream to be selected for decoding. Other values are: 0x01 - select first single channel element (SCE), 0x02 - select first channel pair element (CPE), 0x03 - select first low frequency element (LFE), $S * 16 + 5$ - select SCE number S, $P * 16 + 6$ - select CPE number P, $L * 16 + 7$ - select LFE number L. When automatic selection has been performed, `playSelect` reflects the selected element. The value can be changed while decoding is in progress.

`sceFoundMask`, `cpeFoundMask`, and `lfeFoundMask` indicate which elements have been found in an AAC stream since the variables have last been cleared. The values can be used to present an element selection menu with only the available elements.

`dynCompress` and `dynBoost` change the behavior of the dynamic range control (DRC) that is present in some AAC streams. These are also initialized when AAC decoding starts.

`SCI.HDAT0` contains the average bitrate in bytes per second, is updated once per second and it can be used to calculate an estimate of the remaining playtime.

9.8.4 Midi

Parameter	Address	Usage
midiConfig	0x1943	Miscellaneous configuration
	bits [3:0]	Reverb: 0 = auto (ON if clock $\geq 3.0\times$) 1 = off, 2 - 15 = room size
	bits [6:4]	Play speed: 0 = $1\times$, 1 = $2\times$, 2 = $4\times$, 3 = $8\times$.. 7 = $128\times$
	bits [15:7]	reserved
bytesLeft	0x196a/6b	The number of bytes left in this track

`midiConfig` controls the reverb effect and play speed.

`SCI.HDAT0` contains the average bitrate in bytes per second, is updated once per second and it can be used together with `bytesLeft` to calculate an estimate of the remaining playtime.

9.9 Fast Forward / Rewind

9.9.1 AAC - ADTS

MPEG2.0 Advanced Audio Coded (AAC) defines a stream format suitable for random-access (ADTS). When you want to skip forward or backwards in the file, first send 2052 zeros, then continue sending the file from the new location.

By sending zeros you make certain a partial frame does not cause loud artefacts in the sound. The normal file type checking then finds a new ADTS header and continues decoding.

9.9.2 AAC - ADIF, MP4

MPEG4.0 Advanced Audio Codec (AAC) specifies a multimedia file format (.mp4 / .m4a) but does not specify a stream format and MPEG2.0 AAC specifies a file format (ADIF) in addition to the streamable ADTS format. ADIF and .mp4 / .m4a are not suitable for random-access and it is recommended that they are converted to ADTS format for playback.

However, it is also possible to implement fast forward and rewind for ADIF and .mp4 / .m4a files. The easiest way is to use the `resync` field (see section 9.8.1):

- Write 8192 to `resync`
 - Write 0x1969 to `SCL_WRAMADDR`, Write 0x2000 to `SCL_WRAM`
- Send 2048 zeroes
- Make a seek X in the file ($X > 0$ for forward seek)
- Indicate the low part of the seek amount by writing to `seek1`
 - Write 0x1967 to `SCL_WRAMADDR`, Write $(X - 2048) \& 1023$ to `SCL_WRAM`
- Indicate the high part of the seek amount by writing to `seek2`
 - Write 0x1968 to `SCL_WRAMADDR`, Write $(X - 2048) / 1024$ to `SCL_WRAM`
- Continue sending the file from the new location

Perfect fast forward and rewind can be implemented by using the `jumpPoints` table and making seeks only on packet or data block boundaries.

9.9.3 WMA

Windows Media Audio (WMA) is enclosed as data packets into Advanced Systems Format (ASF) files. This file format is not suitable for random-access.

However, it is also possible to implement fast forward and rewind for WMA files. The easiest way is to use the `resync` field (see Section 9.9.2), perfect fast forward and rewind can be implemented by using the `jumpPoints` table and making seeks only on packet or data block boundaries.

9.9.4 Midi

Midi is not at all suitable for random-access. You can implement fast forward using the `playSpeed` bits of the `midiConfig` field to select 1-128× play speed. `SCI_DECODE_TIME` also speeds up.

If necessary, rewind can be implemented by restarting the decoding of a MIDI file and fast forwarding to the appropriate place. `SCI_DECODE_TIME` can be used to decide when the right place has been reached. This is best suited for soundless rewind.

9.10 SDI Tests

There are several test modes in VS1033, which allow the user to perform memory tests, SCI bus tests, and several different sine wave tests.

All tests are started in a similar way: VS1033 is hardware reset, SM_TESTS is set, and then a test command is sent to the SDI bus. Each test is started by sending a 4-byte special command sequence, followed by 4 zeros. The sequences are described below.

9.10.1 Sine Test

Sine test is initialized with the 8-byte sequence 0x53 0xEF 0x6E *n* 0 0 0 0, where *n* defines the sine test to use. *n* is defined as follows:

<i>n</i> bits		
Name	Bits	Description
F_sIdx	7:5	Sample rate index
<i>S</i>	4:0	Sine skip speed

F_sIdx	F_s
0	44100 Hz
1	48000 Hz
2	32000 Hz
3	22050 Hz
4	24000 Hz
5	16000 Hz
6	11025 Hz
7	12000 Hz

The frequency of the sine to be output can now be calculated from $F = F_s \times \frac{S}{128}$.

Example: Sine test is activated with value 126, which is 0b01111110. Breaking *n* to its components, $F_sIdx = 0b011 = 3$ and thus $F_s = 22050Hz$. $S = 0b11110 = 30$, and thus the final sine frequency $F = 22050Hz \times \frac{30}{128} \approx 5168Hz$.

To exit the sine test, send the sequence 0x45 0x78 0x69 0x74 0 0 0 0.

Note: Sine test signals go through the digital volume control, so it is possible to test channels separately.

9.10.2 Pin Test

Pin test is activated with the 8-byte sequence 0x50 0xED 0x6E 0x54 0 0 0 0. This test is meant for chip production testing only.

9.10.3 Memory Test

Memory test mode is initialized with the 8-byte sequence 0x4D 0xEA 0x6D 0x54 0 0 0 0. After this sequence, wait for 500000 clock cycles. The result can be read from the SCI register SCI_HDAT0, and 'one' bits are interpreted as follows:

Bit(s)	Mask	Meaning
15	0x8000	Test finished
14:7		Unused
6	0x0040	Mux test succeeded
5	0x0020	Good I RAM
4	0x0010	Good Y RAM
3	0x0008	Good X RAM
2	0x0004	Good I ROM
1	0x0002	Good Y ROM
0	0x0001	Good X ROM
	0x807f	All ok

Memory tests overwrite the current contents of the RAM memories.

9.10.4 SCI Test

Sci test is initialized with the 8-byte sequence 0x53 0x70 0xEE *n* 0 0 0 0, where *n* – 48 is the register number to test. The content of the given register is read and copied to SCI_HDAT0. If the register to be tested is HDAT0, the result is copied to SCI_HDAT1.

Example: if *n* is 48, contents of SCI register 0 (SCI_MODE) is copied to SCI_HDAT0.

10 VS1033 Registers

10.1 Who Needs to Read This Chapter

User software is required when a user wishes to add some own functionality like DSP effects to VS1033.

However, most users of VS1033 don't need to worry about writing their own code, or about this chapter, including those who only download software plug-ins from VLSI Solution's Web site.

10.2 The Processor Core

VS_DSP is a 16/32-bit DSP processor core that also had extensive all-purpose processor features. VLSI Solution's free VSKIT Software Package contains all the tools and documentation needed to write, simulate and debug Assembly Language or Extended ANSI C programs for the VS_DSP processor core. VLSI Solution also offers a full Integrated Development Environment VSIDE for full debug capabilities.

10.3 VS1033 Memory Map

VS1033's Memory Map is shown in Figure 16.

10.4 SCI Registers

SCI registers described in Chapter 8.7 can be found here between 0xC000..0xC00F. In addition to these registers, there is one in address 0xC010, called SCI_CHANGE.

SCI registers, prefix SCI_				
Reg	Type	Reset	Abbrev[bits]	Description
0xC010	r	0	CHANGE[5:0]	Last SCI access address

SCI_CHANGE bits		
Name	Bits	Description
SCI.CH_WRITE	4	1 if last access was a write cycle
SCI.CH_ADDR	3:0	SCI address of last access

10.5 Serial Data Registers

SDI registers, prefix SER_				
Reg	Type	Reset	Abbrev[bits]	Description
0xC011	r	0	DATA	Last received 2 bytes, big-endian
0xC012	w	0	DREQ[0]	DREQ pin control

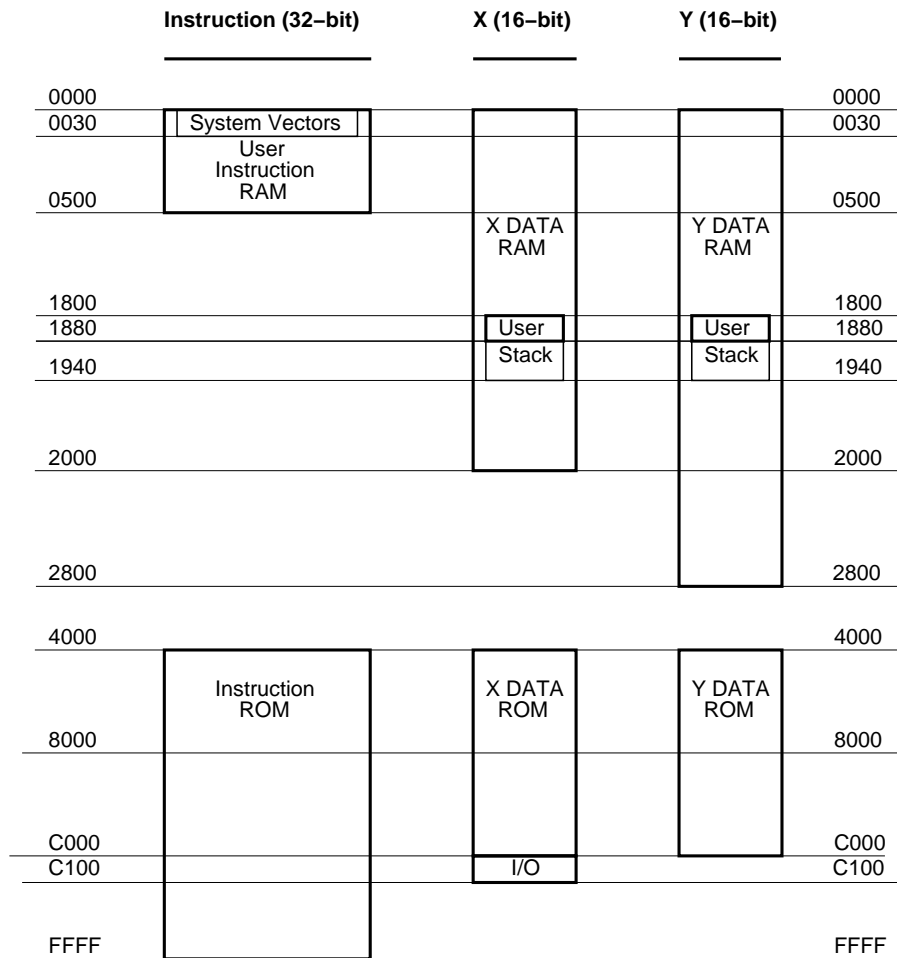

Figure 16: User's Memory Map.

10.6 DAC Registers

DAC registers, prefix DAC_				
Reg	Type	Reset	Abbrev[bits]	Description
0xC013	rw	0	FCTLL	DAC frequency control, 16 LSbs
0xC014	rw	0	FCTLH	DAC frequency control 4MSbs, PLL control
0xC015	rw	0	LEFT	DAC left channel PCM value
0xC016	rw	0	RIGHT	DAC right channel PCM value

Every fourth clock cycle, an internal 26-bit counter is added to by $(\text{DAC_FCTLH} \& 15) \times 65536 + \text{DAC_FCTLL}$. Whenever this counter overflows, values from DAC_LEFT and DAC_RIGHT are read and a DAC interrupt is generated.

10.7 GPIO Registers

GPIO registers, prefix GPIO_				
Reg	Type	Reset	Abbrev[bits]	Description
0xC017	rw	0	DDR[7:0]	Direction
0xC018	r	0	IDATA[7:0]	Values read from the pins
0xC019	rw	0	ODATA[7:0]	Values set to the pins

GPIO_DIR is used to set the direction of the GPIO pins. 1 means output. GPIO_ODATA remembers its values even if a GPIO_DIR bit is set to input.

GPIO registers don't generate interrupts.

Note that in VS1033 the VSDSP registers can be read and written through the SCI_WRAMADDR and SCI_WRAM registers. You can thus use the GPIO pins quite conveniently.

10.8 Interrupt Registers

Interrupt registers, prefix INT_				
Reg	Type	Reset	Abbrev[bits]	Description
0xC01A	rw	0	ENABLE[7:0]	Interrupt enable
0xC01B	w	0	GLOB_DIS[-]	Write to add to interrupt counter
0xC01C	w	0	GLOB_ENA[-]	Write to subtract from interrupt counter
0xC01D	rw	0	COUNTER[4:0]	Interrupt counter

INT_ENABLE controls the interrupts. The control bits are as follows:

INT_ENABLE bits		
Name	Bits	Description
INT_EN_TIM1	7	Enable Timer 1 interrupt
INT_EN_TIM0	6	Enable Timer 0 interrupt
INT_EN_RX	5	Enable UART RX interrupt
INT_EN_TX	4	Enable UART TX interrupt
INT_EN_MODU	3	Enable AD modulator interrupt
INT_EN_SDI	2	Enable Data interrupt
INT_EN_SCI	1	Enable SCI interrupt
INT_EN_DAC	0	Enable DAC interrupt

Note: It may take up to 6 clock cycles before changing INT_ENABLE has any effect.

Writing any value to INT_GLOB_DIS adds one to the interrupt counter INT_COUNTER and effectively disables all interrupts. It may take up to 6 clock cycles before writing to this register has any effect.

Writing any value to INT_GLOB_ENA subtracts one from the interrupt counter (unless INT_COUNTER already was 0). If the interrupt counter becomes zero, interrupts selected with INT_ENABLE are re-stored. An interrupt routine should always write to this register as the last thing it does, because interrupts automatically add one to the interrupt counter, but subtracting it back to its initial value is the responsibility of the user. It may take up to 6 clock cycles before writing this register has any effect.

By reading INT_COUNTER the user may check if the interrupt counter is correct or not. If the register is not 0, interrupts are disabled.

10.9 A/D Modulator Registers

Interrupt registers, prefix AD_				
Reg	Type	Reset	Abbrev[bits]	Description
0xC01E	rw	0	DIV	A/D Modulator divider
0xC01F	rw	0	DATA	A/D Modulator data

AD_DIV bits		
Name	Bits	Description
ADM_POWERDOWN	15	1 in powerdown
ADM_DIVIDER	14:0	Divider

ADM_DIVIDER controls the AD converter's sampling frequency. To gather one sample, $128 \times n$ clock cycles are used (n is value of AD_DIV). The lowest usable value is 4, which gives a 48 kHz sample rate when CLKI is 24.576 MHz. When ADM_POWERDOWN is 1, the A/D converter is turned off.

AD_DATA contains the latest decoded A/D value.

10.10 Watchdog v1.0 2002-08-26

The watchdog consist of a watchdog counter and some logic. After reset, the watchdog is inactive. The counter reload value can be set by writing to WDOG_CONFIG. The watchdog is activated by writing 0x4ea9 to register WDOG_RESET. Every time this is done, the watchdog counter is reset. Every 65536'th clock cycle the counter is decremented by one. If the counter underflows, it will activate vs-dsp's internal reset sequence.

Thus, after the first 0x4ea9 write to WDOG_RESET, subsequent writes to the same register with the same value must be made no less than every $65536 \times \text{WDOG_CONFIG}$ clock cycles.

Once started, the watchdog cannot be turned off. Also, a write to WDOG_CONFIG doesn't change the counter reload value.

After watchdog has been activated, any read/write operation from/to WDOG_CONFIG or WDOG_DUMMY will invalidate the next write operation to WDOG_RESET. This will prevent runaway loops from re-setting the counter, even if they do happen to write the correct number. Writing a wrong value to WDOG_RESET will also invalidate the next write to WDOG_RESET.

Reads from watchdog registers return undefined values.

10.10.1 Registers

Watchdog, prefix WDOG_				
Reg	Type	Reset	Abbrev	Description
0xC020	w	0	CONFIG	Configuration
0xC021	w	0	RESET	Clock configuration
0xC022	w	0	DUMMY[-]	Dummy register

10.11.3 Data UARTx_DATA

A read from UARTx_DATA returns the received byte in bits 7:0, bits 15:8 are returned as '0'. If there is no more data to be read, the receiver data register full indicator will be cleared.

A receive interrupt will be generated when a byte is moved from the receiver shift register to the receiver data register.

A write to UARTx_DATA sets a byte for transmission. The data is taken from bits 7:0, other bits in the written value are ignored. If the transmitter is idle, the byte is immediately moved to the transmitter shift register, a transmit interrupt request is generated, and transmission is started. If the transmitter is busy, the UART_ST_TXFULL will be set and the byte remains in the transmitter data register until the previous byte has been sent and transmission can proceed.

10.11.4 Data High UARTx_DATAH

The same as UARTx_DATA, except that bits 15:8 are used.

10.11.5 Divider UARTx_DIV

UARTx_DIV Bits		
Name	Bits	Description
UART_DIV_D1	15:8	Divider 1 (0..255)
UART_DIV_D2	7:0	Divider 2 (6..255)

The divider is set to 0x0000 in reset. The ROM boot code must initialize it correctly depending on the master clock frequency to get the correct bit speed. The second divider (D_2) must be from 6 to 255.

The communication speed $f = \frac{f_m}{(D_1+1) \times (D_2)}$, where f_m is the master clock frequency, and f is the TX/RX speed in bps.

Divider values for common communication speeds at 26 MHz master clock:

Example UART Speeds, $f_m = 26MHz$		
Comm. Speed [bps]	UART_DIV_D1	UART_DIV_D2
4800	85	63
9600	42	63
14400	42	42
19200	51	26
28800	42	21
38400	25	26
57600	1	226
115200	0	226

10.11.6 Interrupts and Operation

Transmitter operates as follows: After an 8-bit word is written to the transmit data register it will be transmitted instantly if the transmitter is not busy transmitting the previous byte. When the transmission begins a TX_INTR interrupt will be sent. Status bit [1] informs the transmitter data register empty (or full state) and bit [0] informs the transmitter (shift register) empty state. A new word must not be written to transmitter data register if it is not empty (bit [1] = '0'). The transmitter data register will be empty as soon as it is shifted to transmitter and the transmission is begun. It is safe to write a new word to transmitter data register every time a transmit interrupt is generated.

Receiver operates as follows: It samples the RX signal line and if it detects a high to low transition, a start bit is found. After this it samples each 8 bit at the middle of the bit time (using a constant timer), and fills the receiver (shift register) LSB first. Finally the data in the receiver is moved to the receive data register, the stop bit state is checked (logic high = ok, logic low = framing error) for status bit[4], the RX_INTR interrupt is sent, status bit[2] (receive data register full) is set, and status bit[2] old state is copied to bit[3] (receive data overrun). After that the receiver returns to idle state to wait for a new start bit. Status bit[2] is zeroed when the receiver data register is read.

RS232 communication speed is set using two clock dividers. The base clock is the processor master clock. Bits 15-8 in these registers are for first divider and bits 7-0 for second divider. RX sample frequency is the clock frequency that is input for the second divider.

10.12 Timers v1.0 2002-04-23

There are two 32-bit timers that can be initialized and enabled independently of each other. If enabled, a timer initializes to its start value, written by a processor, and starts decrementing every clock cycle. When the value goes past zero, an interrupt is sent, and the timer initializes to the value in its start value register, and continues downcounting. A timer stays in that loop as long as it is enabled.

A timer has a 32-bit timer register for down counting and a 32-bit TIMER1_LH register for holding the timer start value written by the processor. Timers have also a 2-bit TIMER_ENA register. Each timer is enabled (1) or disabled (0) by a corresponding bit of the enable register.

10.12.1 Registers

Timer registers, prefix TIMER_				
Reg	Type	Reset	Abbrev	Description
0xC030	r/w	0	CONFIG[7:0]	Timer configuration
0xC031	r/w	0	ENABLE[1:0]	Timer enable
0xC034	r/w	0	T0L	Timer0 startvalue - LSBs
0xC035	r/w	0	T0H	Timer0 startvalue - MSBs
0xC036	r/w	0	T0CNTL	Timer0 counter - LSBs
0xC037	r/w	0	T0CNTH	Timer0 counter - MSBs
0xC038	r/w	0	T1L	Timer1 startvalue - LSBs
0xC039	r/w	0	T1H	Timer1 startvalue - MSBs
0xC03A	r/w	0	T1CNTL	Timer1 counter - LSBs
0xC03B	r/w	0	T1CNTH	Timer1 counter - MSBs

10.12.2 Configuration TIMER_CONFIG

TIMER_CONFIG Bits		
Name	Bits	Description
TIMER_CF_CLKDIV	7:0	Master clock divider

TIMER_CF_CLKDIV is the master clock divider for all timer clocks. The generated internal clock frequency $f_i = \frac{f_m}{c+1}$, where f_m is the master clock frequency and c is TIMER_CF_CLKDIV. Example: With a 12 MHz master clock, TIMER_CF_DIV=3 divides the master clock by 4, and the output/sampling clock would thus be $f_i = \frac{12MHz}{3+1} = 3MHz$.

10.12.3 Configuration **TIMER_ENABLE**

TIMER_ENABLE Bits		
Name	Bits	Description
TIMER_EN_T1	1	Enable timer 1
TIMER_EN_T0	0	Enable timer 0

10.12.4 Timer X Startvalue **TIMER_Tx[L/H]**

The 32-bit start value **TIMER_Tx[L/H]** sets the initial counter value when the timer is reset. The timer interrupt frequency $f_t = \frac{f_i}{c+1}$ where f_i is the master clock obtained with the clock divider (see Chapter 10.12.2 and c is **TIMER_Tx[L/H]**).

Example: With a 12 MHz master clock and with **TIMER_CF_CLKDIV=3**, the master clock $f_i = 3MHz$. If **TIMER_TH=0**, **TIMER_TL=99**, then the timer interrupt frequency $f_t = \frac{3MHz}{99+1} = 30kHz$.

10.12.5 Timer X Counter **TIMER_TxCNT[L/H]**

TIMER_TxCNT[L/H] contains the current counter values. By reading this register pair, the user may get knowledge of how long it will take before the next timer interrupt. Also, by writing to this register, a one-shot different length timer interrupt delay may be realized.

10.12.6 Interrupts

Each timer has its own interrupt, which is asserted when the timer counter underflows.

10.13 I2S DAC Interface

The I2S Interface makes it possible to attach an external DAC to the system.

10.13.1 Registers

I2S registers, prefix I2S_				
Reg	Type	Reset	Abbrev	Description
0xC040	r/w	0	CONFIG[3:0]	I2S configuration

10.13.2 Configuration I2S_CONFIG

I2S_CONFIG Bits		
Name	Bits	Description
I2S_CF_MCLK_ENA	3	Enables the MCLK output (12.288 MHz)
I2S_CF_ENA	2	Enables I2S, otherwise pins are GPIO
I2S_CF_SRATE	1:0	I2S rate, "10" = 192, "01" = 96, "00" = 48 kHz

I2S_CF_ENA enables the I2S interface. After reset the interface is disabled and the pins are used for GPIO.

I2S_CF_MCLK_ENA enables the MCLK output. The frequency is either directly the input clock (nominal 12.288 MHz), or half the input clock when mode register bit SM_CLK_RANGE is set to 1 (24-26 MHz input clock).

I2S_CF_SRATE controls the output samplerate. When set to 48 kHz, SCLK is MCLK divided by 8, when 96 kHz SCLK is MCLK divided by 4, and when 192 kHz SCLK is MCLK divided by 2.

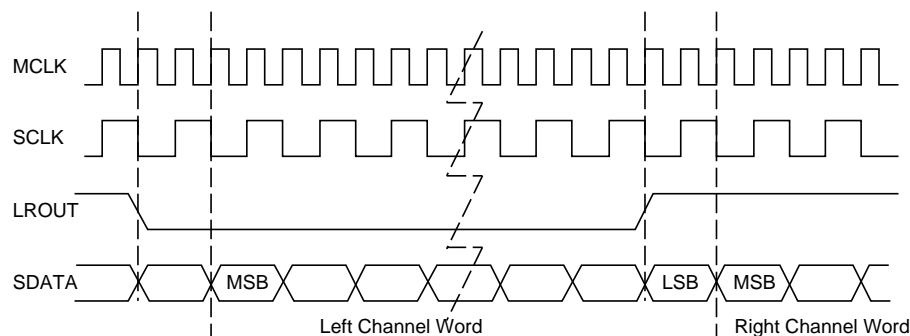

Figure 18: I2S Interface, 192 kHz.

To enable I2S first write 0xc017 to SCI_WRAMADDR and 0x33 to SCI_WRAM, then write 0xc040 to SCI_WRAMADDR and 0x0c to SCI_WRAM.

See application notes for more information.

10.14 System Vector Tags

The System Vector Tags are tags that may be replaced by the user to take control over several decoder functions.

10.14.1 AudioInt, 0x20

Normally contains the following VS_DSP assembly code:

```
jmp i DAC_INT_ADDRESS, (i6)+1
```

The user may, at will, replace the first instruction with a *jmp i* command to gain control over the audio interrupt.

10.14.2 SciInt, 0x21

Normally contains the following VS_DSP assembly code:

```
jmp i SCI_INT_ADDRESS, (i6)+1
```

The user may, at will, replace the instruction with a *jmp i* command to gain control over the SCI interrupt.

10.14.3 DataInt, 0x22

Normally contains the following VS_DSP assembly code:

```
jmp i SDI_INT_ADDRESS, (i6)+1
```

The user may, at will, replace the instruction with a *jmp i* command to gain control over the SDI interrupt.

10.14.4 ModuInt, 0x23

Normally contains the following VS_DSP assembly code:

```
jmp i MODU_INT_ADDRESS, (i6)+1
```

The user may, at will, replace the instruction with a *jmp i* command to gain control over the AD Modulator interrupt.

10.14.5 TxInt, 0x24

Normally contains the following VS_DSP assembly code:

```
jmp i EMPTY_INT_ADDRESS, (i6)+1
```

The user may, at will, replace the instruction with a *jmp i* command to gain control over the UART TX interrupt.

10.14.6 RxInt, 0x25

Normally contains the following VS_DSP assembly code:

```
jmp i RX_INT_ADDRESS, (i6)+1
```

The user may, at will, replace the first instruction with a *jmp i* command to gain control over the UART RX interrupt.

10.14.7 Timer0Int, 0x26

Normally contains the following VS_DSP assembly code:

```
jmp i EMPTY_INT_ADDRESS, (i6)+1
```

The user may, at will, replace the first instruction with a *jmp i* command to gain control over the Timer 0 interrupt.

10.14.8 Timer1Int, 0x27

Normally contains the following VS_DSP assembly code:

```
jmp i EMPTY_INT_ADDRESS, (i6)+1
```

The user may, at will, replace the first instruction with a *jmp i* command to gain control over the Timer 1 interrupt.

10.14.9 UserCodec, 0x0

Normally contains the following VS_DSP assembly code:

```
jr  
nop
```

If the user wants to take control away from the standard decoder, the first instruction should be replaced with an appropriate *j* command to user's own code.

The system activates the user program in less than 1 ms. After this, the user should steal interrupt vectors from the system, and insert user programs.

10.15 System Vector Functions

The System Vector Functions are pointers to some functions that the user may call to help implementing his own applications.

10.15.1 WriteIRam(), 0x2

VS_DSP C prototype:

```
void WriteIRam(register __i0 u_int16 *addr, register __a1 u_int16 msW, register __a0 u_int16 lsW);
```

This is the preferred way to write to the User Instruction RAM.

10.15.2 ReadIRam(), 0x4

VS_DSP C prototype:

```
u_int32 ReadIRam(register __i0 u_int16 *addr);
```

This is the preferred way to read from the User Instruction RAM.

A1 contains the MSBs and A0 the LSBs of the result.

10.15.3 DataBytes(), 0x6

VS_DSP C prototype:

```
u_int16 DataBytes(void);
```

If the user has taken over the normal operation of the system by switching the pointer in UserCodec to point to his own code, he may read data from the Data Interface through this and the following two functions.

This function returns the number of data bytes that can be read.

10.15.4 GetDataByte(), 0x8

VS_DSP C prototype:

```
u_int16 GetDataByte(void);
```

Reads and returns one data byte from the Data Interface. This function will wait until there is enough data in the input buffer. Audio interrupts must be enabled for this function to work.

10.15.5 GetDataWords(), 0xa

VS_DSP C prototype:

```
void GetDataWords(register __i0 __y u_int16 *d, register __a0 u_int16 n);
```

Read *n* data byte pairs and copy them in big-endian format (first byte to MSBs) to *d*. This function will wait until there is enough data in the input buffer. Audio interrupts must be enabled for this function to work.

11 Document Version Changes

This chapter describes the most important changes to this document.

Version 1.00 for VS1033c, 2008-02-01

- Production version, removed “PRELIMINARY” tag.
- Fully qualified values to tables in Chapter 4.
- Added an example to Chapter 9.7, Feeding PCM Data.

Version 0.92 for VS1033c, 2008-01-16

- Max SCI speed changed to CLKI/7.
- Typical connection diagram updated.
- Max CLKI changed to 50 MHz.
- AVDD recommended minimum set to 2.7 V.

Version 0.91 for VS1033c, 2007-02-12

- GBUF connection in Connection diagram changed (figure 3 in section 6). GBUF must have 10 Ω and 47 nF to ground.
- Mention of the 8 kHz Phone Application removed. Other features have replaced this code in VS1033c.

Version 0.9 for VS1033c, 2006-08-15

- EarSpeaker documentation added.

Version 0.8 for VS1033b, 2006-05-19

- Mention of quiet power-off added to feature list.

Version 0.6 for VS1033a, 2006-01-05

- ADPCM recording section added (section 9.4).

12 Contact Information

VLSI Solution Oy
Entrance G, 2nd floor
Hermiankatu 8
FIN-33720 Tampere
FINLAND

Fax: +358-3-3140-8288
Phone: +358-3-3140-8200
Email: sales@vlsi.fi
URL: <http://www.vlsi.fi/>