

MAPLST1617-030CF



LDMOS RF Line Power FET Transistor
30 W , 1600-1700 MHz, 28V

Discontinued
(For Reference Only)

Product Image

Designed for INMARSAT applications in the 1620-1670 MHz frequency band.

- Typical two tone performance (IMD=-30 dBc):
Average output power: 15W
Gain: 14dB (typ.)
Efficiency: 38% (typ.)
- 10:1 VSWR ruggedness at 30W, 28V,1670MHz)

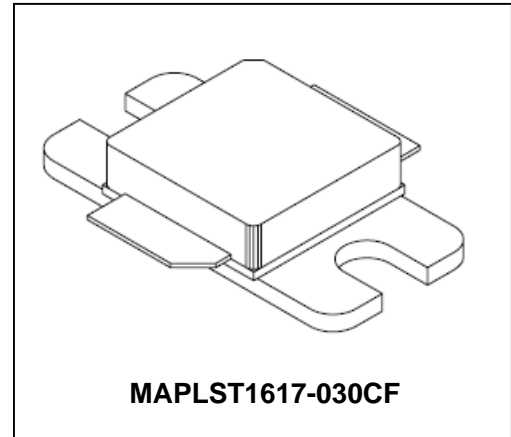

MAXIMUM RATINGS

Parameter	Symbol	Rating	Units
Drain—Source Voltage	V_{DSS}	65	V_{dc}
Gate—Source Voltage	V_{GS}	20	V_{dc}
Total Power Dissipation @ $T_C = 25\text{ }^\circ\text{C}$	P_D	97	W
Storage Temperature	T_{STG}	-40 to +150	$^\circ\text{C}$
Junction Temperature	T_J	+200	$^\circ\text{C}$

THERMAL CHARACTERISTICS

Characteristic	Symbol	Max	Unit
Thermal Resistance, Junction to Case	$R_{\theta JC}$	1.8	$^\circ\text{C/W}$

NOTE—**CAUTION**—MOS devices are susceptible to damage from electrostatic charge. Precautions in handling and packaging MOS devices should be observed.

1

ADVANCED: Data Sheets contain information regarding a product M/A-COM Technology Solutions is considering for development. Performance is based on target specifications, simulated results, and/or prototype measurements. Commitment to develop is not guaranteed.
PRELIMINARY: Data Sheets contain information regarding a product M/A-COM Technology Solutions has under development. Performance is based on engineering tests. Specifications are typical. Mechanical outline has been fixed. Engineering samples and/or test data may be available. Commitment to produce in volume is not guaranteed.

• **North America** Tel: 800.366.2266 / Fax: 978.366.2266
• **Europe** Tel: 44.1908.574.200 / Fax: 44.1908.574.300
• **Asia/Pacific** Tel: 81.44.844.8296 / Fax: 81.44.844.8298
Visit www.macomtech.com for additional data sheets and product information.

M/A-COM Technology Solutions Inc. and its affiliates reserve the right to make changes to the product(s) or information contained herein without notice.

MAPLST1617-030CF



LDMOS RF Line Power FET Transistor
30 W , 1600-1700 MHz, 28V

Discontinued
(For Reference Only)

Characteristic	Symbol	Min	Typ	Max	Unit
DC CHARACTERISTICS @ 25°C					
Drain-Source Breakdown Voltage ($V_{GS} = 0$ Vdc, $I_D = 20$ μ Adc)	$V_{(BR)DSS}$	65	—	—	Vdc
Zero Gate Voltage Drain Leakage Current ($V_{DS} = 28$ Vdc, $V_{GS} = 0$)	I_{DSS}	—	—	1	μ Adc
Gate—Source Leakage Current ($V_{GS} = 5$ Vdc, $V_{DS} = 0$)	I_{GSS}	—	—	1	μ Adc
Gate Threshold Voltage ($V_{DS} = 10$ Vdc, $I_D = 1$ mA)	$V_{GS(th)}$	2	—	4	Vdc
Gate Quiescent Voltage ($V_{DS} = 28$ Vdc, $I_D = 250$ mA)	$V_{DS(Q)}$	2	—	4.5	Vdc
Drain-Source On-Voltage ($V_{GS} = 10$ Vdc, $I_D = 1$ A)	$V_{DS(on)}$	—	0.2	—	Vdc
Forward Transconductance ($V_{GS} = 10$ Vdc, $I_D = 1$ A)	Gm	—	1.2	—	S
DYNAMIC CHARACTERISTICS @ 25°C					
Input Capacitance (Including Input Matching Capacitor in Package) ($V_{DS} = 28$ Vdc, $V_{GS} = 0$, $f = 1$ MHz)	C_{iss}	—	90	—	pF
Output Capacitance ($V_{DS} = 28$ Vdc, $V_{GS} = 0$, $f = 1$ MHz)	C_{oss}	—	32.5	—	pF
Reverse Transfer Capacitance ($V_{DS} = 28$ Vdc, $V_{GS} = 0$, $f = 1$ MHz)	C_{rss}	—	1.5	—	pF
RF FUNCTIONAL TESTS @ 25°C (In M/A-COM Test Fixture)					
CW Gain ($V_{DS} = 28$ Vdc, $P_{OUT} = 30$ W (avg.), $I_{DQ} = 250$ mA, $f_0 = 1670$ MHz)	G_{ps}	—	14	—	dB
CW Drain Efficiency ($V_{DS} = 28$ Vdc, $P_{OUT} = 30$ W (avg.), $I_{DQ} = 250$ mA, $f_0 = 1670$ MHz)	EFF (η)	—	50	—	%
CW Input Return Loss ($V_{DS} = 28$ Vdc, $P_{OUT} = 30$ W (avg.), $I_{DQ} = 250$ mA, $f_0 = 1670$ MHz)	IRL	—	-10	-9	dB
IMD ($V_{DS} = 28$ Vdc, $P_{OUT} = 15$ W (avg.) (30 W PEP), $I_{DQ} = 250$ mA, $f_0 = 1670$ MHz, $f_1 = 1670.1$ MHz)	IMD	—	-30	—	dBc
Output VSWR Tolerance ($V_{DS} = 28$ Vdc, $P_{OUT} = 30$ W (avg.), $I_{DQ} = 250$ mA, $f_0 = 1670$ MHz)	Ψ	No Degradation In Output Power Before and After Test			

(1) Device specifications obtained on a Production Test Fixture.

MAPLST1617-030CF

LDMOS RF Line Power FET Transistor
30 W , 1600-1700 MHz, 28V

Discontinued
(For Reference Only)

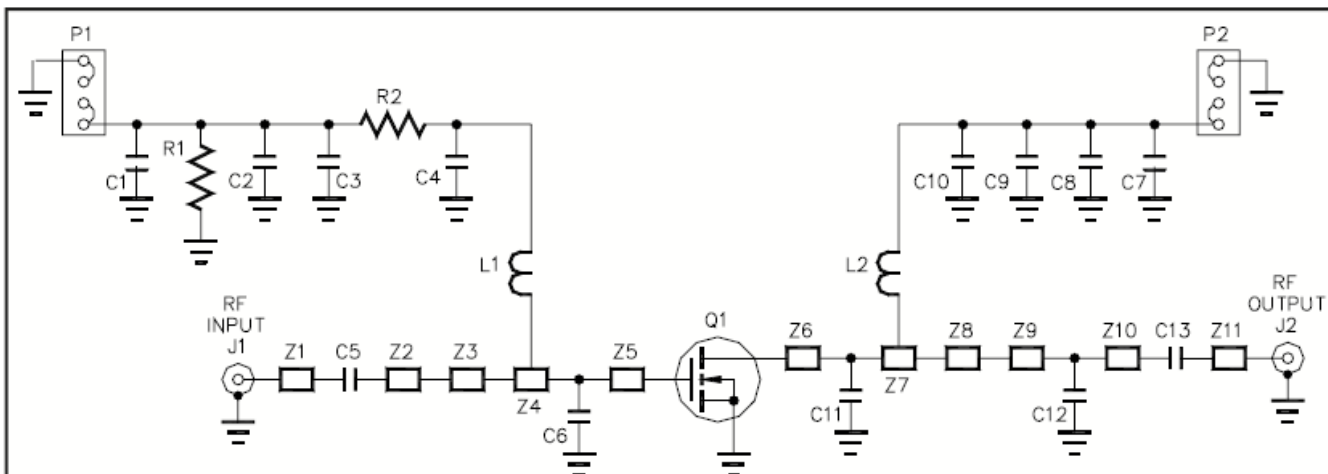

- | | | | |
|---------------|--|-----|---|
| C1,C7 | Electrolytic Surface Mt. Cap., 100 μ F | Z1 | Distributed Microstrip Element, 0.820" x 0.082" |
| C2,C8 | Ceramic Chip Capacitor, 0.1 μ F | Z2 | Distributed Microstrip Element, 0.590" x 0.082" |
| C3,C9 | Ceramic Chip Capacitor, 1000 pF | Z3 | Distributed Microstrip Element, 0.370" x 0.160" |
| C4,C5,C10,C13 | Chip Capacitor, 10 pF ATC100B | Z4 | Distributed Microstrip Element, 0.320" x 0.300" |
| C6,C11 | Chip Capacitor, 1.2 pF ATC100B | Z5 | Distributed Microstrip Element, 0.140" x 0.300" |
| C12 | Chip Capacitor, 1.0 pF ATC100B | Z6 | Distributed Microstrip Element, 0.040" x 0.660" |
| J1,J2 | SMA Connector, Omni Spectra 2052-5636-02 | Z7 | Distributed Microstrip Element, 0.186" x 0.660" |
| L1,L2 | Inductor, 35.5 nH, CoilCraft B09T | Z8 | Distributed Microstrip Element, 0.425" x 0.380" |
| P1,P2 | Connector, AMP 640457-4 | Z9 | Distributed Microstrip Element, 0.150" x 0.082" |
| Q1 | Transistor, MAPLST1617-030CF | Z10 | Distributed Microstrip Element, 0.610" x 0.082" |
| R1 | Chip Resistor (0805), 10k Ohm | Z11 | Distributed Microstrip Element, 0.820" x 0.082" |
| R2 | Chip Resistor (0805), 10 Ohm | | |

PC Board (74350132-01), Arlon (GX03005522) Woven GlassTeflon .031" Thick, Er=2.5, 2 Oz Copper Both Sides

FIGURE 1. 1620—1670 MHZ TEST FIXTURE SCHEMATIC

MAPLST1617-030CF



LDMOS RF Line Power FET Transistor
30 W , 1600-1700 MHz, 28V

Discontinued
(For Reference Only)

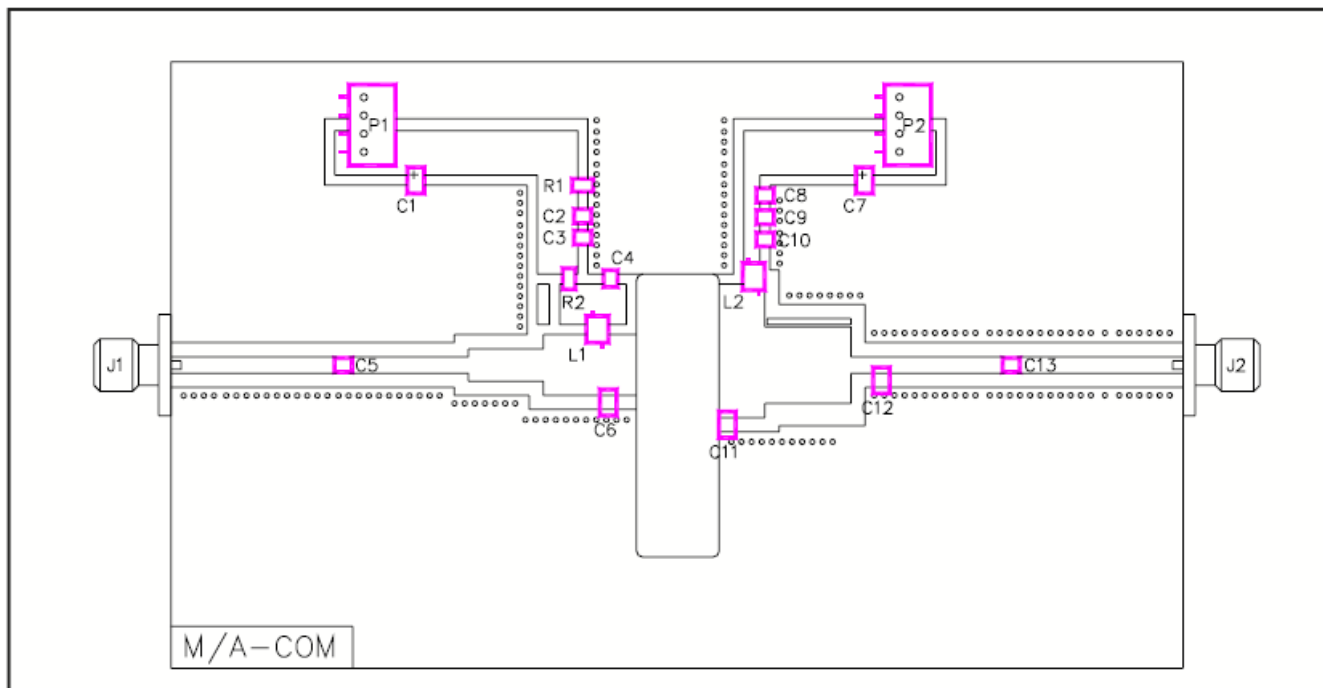

FIGURE 2. 1620—1670 MHz TEST FIXTURE COMPONENT LAYOUT

ADVANCED: Data Sheets contain information regarding a product M/A-COM Technology Solutions is considering for development. Performance is based on target specifications, simulated results, and/or prototype measurements. Commitment to develop is not guaranteed.
PRELIMINARY: Data Sheets contain information regarding a product M/A-COM Technology Solutions has under development. Performance is based on engineering tests. Specifications are typical. Mechanical outline has been fixed. Engineering samples and/or test data may be available. Commitment to produce in volume is not guaranteed.

• **North America** Tel: 800.366.2266 / Fax: 978.366.2266
• **Europe** Tel: 44.1908.574.200 / Fax: 44.1908.574.300
• **Asia/Pacific** Tel: 81.44.844.8296 / Fax: 81.44.844.8298
Visit www.macontech.com for additional data sheets and product information.

M/A-COM Technology Solutions Inc. and its affiliates reserve the right to make changes to the product(s) or information contained herein without notice.

LDMOS RF Line Power FET Transistor
30 W , 1600-1700 MHz, 28V

Discontinued
(For Reference Only)

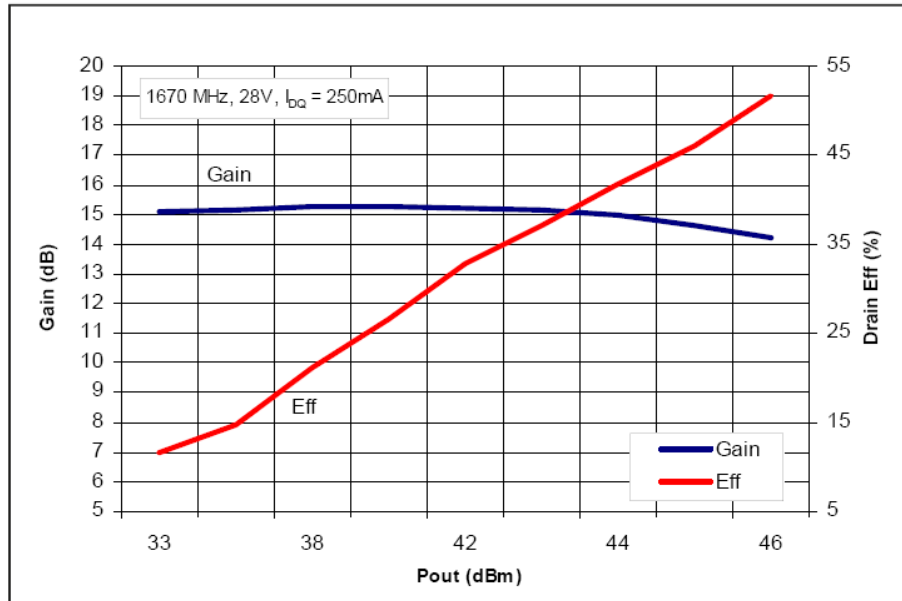

GRAPH 1. CW: GAIN AND EFFICIENCY VS. OUTPUT POWER

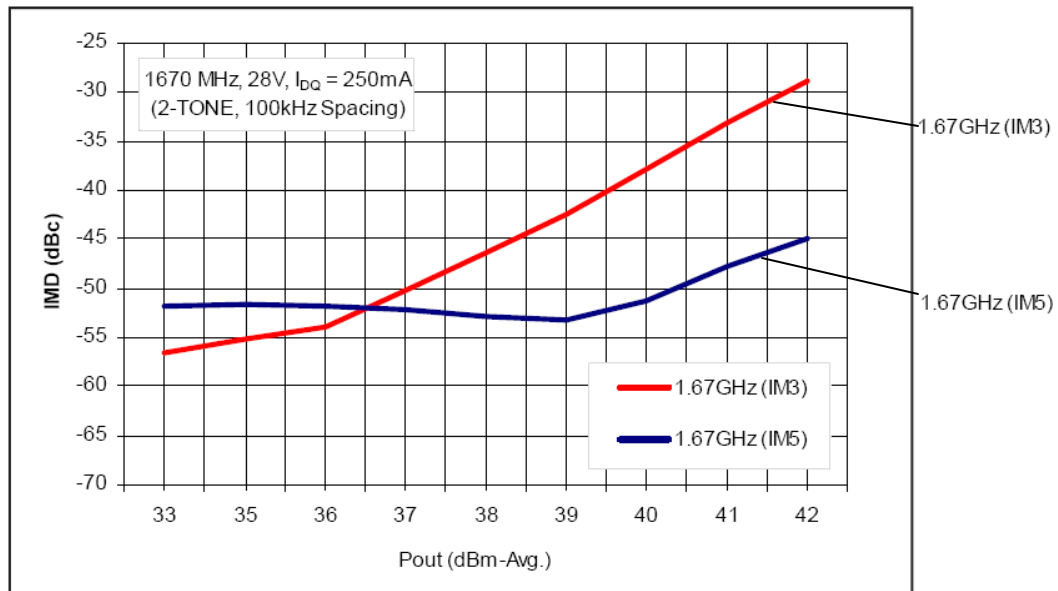

GRAPH 2. TWO TONE: INTERMODULATION DISTORTION VS. OUTPUT POWER

MAPLST1617-030CF

LDMOS RF Line Power FET Transistor
30 W , 1600-1700 MHz, 28V

Discontinued
(For Reference Only)

PACKAGE DIMENSIONS

