

THE INFORMATION CONTAINED HEREIN IS CONSIDERED "PROPRIETARY" TO BEL FUSE INC. AND SHALL NOT BE COPIED, REPRODUCED OR DISCLOSED WITHOUT THE WRITTEN APPROVAL OF BEL FUSE INC.

RoHS
2002/95/EC



LED1 POLARITY			LED2 POLARITY		
PIN 11	PIN 12	COLOR	PIN 13	PIN 14	COLOR
-	+	YELLOW	-	+	GREEN

ELECTRICAL CHARACTERISTICS @ 25°C

URNS RATIO

TX 1CT : 1
RX 1CT : 1

OCL @ 100kHz/100mVRMS

8mA DC BIAS 350mH MIN.

INS. LOSS

1MHz TO 100MHz -1.0 dB MAX

RET. LOSS (MIN)

1MHz-30MHz -18 dB
30MHz-60MHz $-18+20\text{LOG}(F/30\text{MHz})$ dB
60MHz-80MHz -12 dB

CROSS TALK (TX - RX)

500kHz - 100 MHz -35 dB MIN

CM TO CM REJ

100kHz - 100 MHz -30 dB MIN

CM TO DM REJ

100kHz - 100 MHz -40 dB MIN

HIPOT (Isolation Voltage): 1500 Vrms or 2250VDC

100% OF PRODUCTION TESTED TO COMPLY WITH IEEE 802.3 ISOLATION REQUIREMENTS.

LED 1

VF (FORWARD VOLTAGE) IF=20mA YELLOW 2.1V TYP.
 λ D (DOMINANT WAVELENGTH) IF=20mA YELLOW 590nm TYP.

LED 2

VF (FORWARD VOLTAGE) IF=20mA GREEN 2.2V TYP.
 λ D (DOMINANT WAVELENGTH) IF=20mA GREEN 565nm TYP.

SCHEMATIC

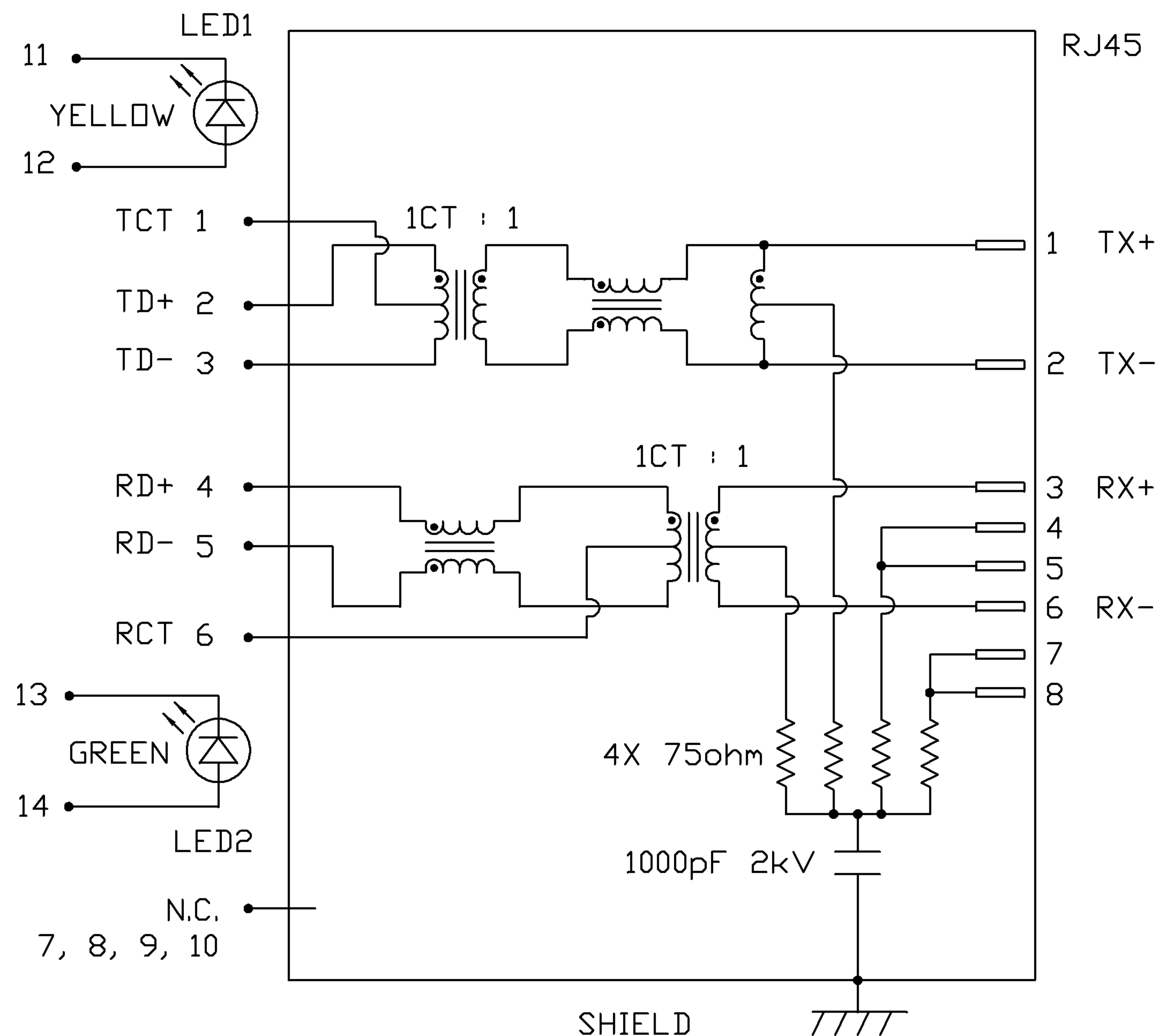

ORIGINATED BY	DATE	TITLE	PART NO. / DRAWING NO.	STANDARD DIM. TOL. IN INCH	[] METRIC DIM. AS REFERENCE
CHOW WANCHUNG	07-31-08	MagJack®	08261AX147-F	.X	UNIT : INCH [mm] REV. : C
DRAWN BY	DATE	(Dual Stuff Option, Tab Up)	FILE NAME	.XX	SCALE : N/A SIZE : A4
WEIDE LEE	07-31-08	0826-1AX1-47-F	08261AX147-F_C.DWG	.XXX	PAGE : 2



THE INFORMATION CONTAINED HEREIN IS CONSIDERED "PROPRIETARY" TO BEL FUSE INC. AND SHALL NOT BE COPIED, REPRODUCED OR DISCLOSED WITHOUT THE WRITTEN APPROVAL OF BEL FUSE INC.

RoHS
2002/95/EC



MECHANICAL SPECIFICATION

RECOMMENDED PCB FOOTPRINT
COMPONENT SIDE VIEW

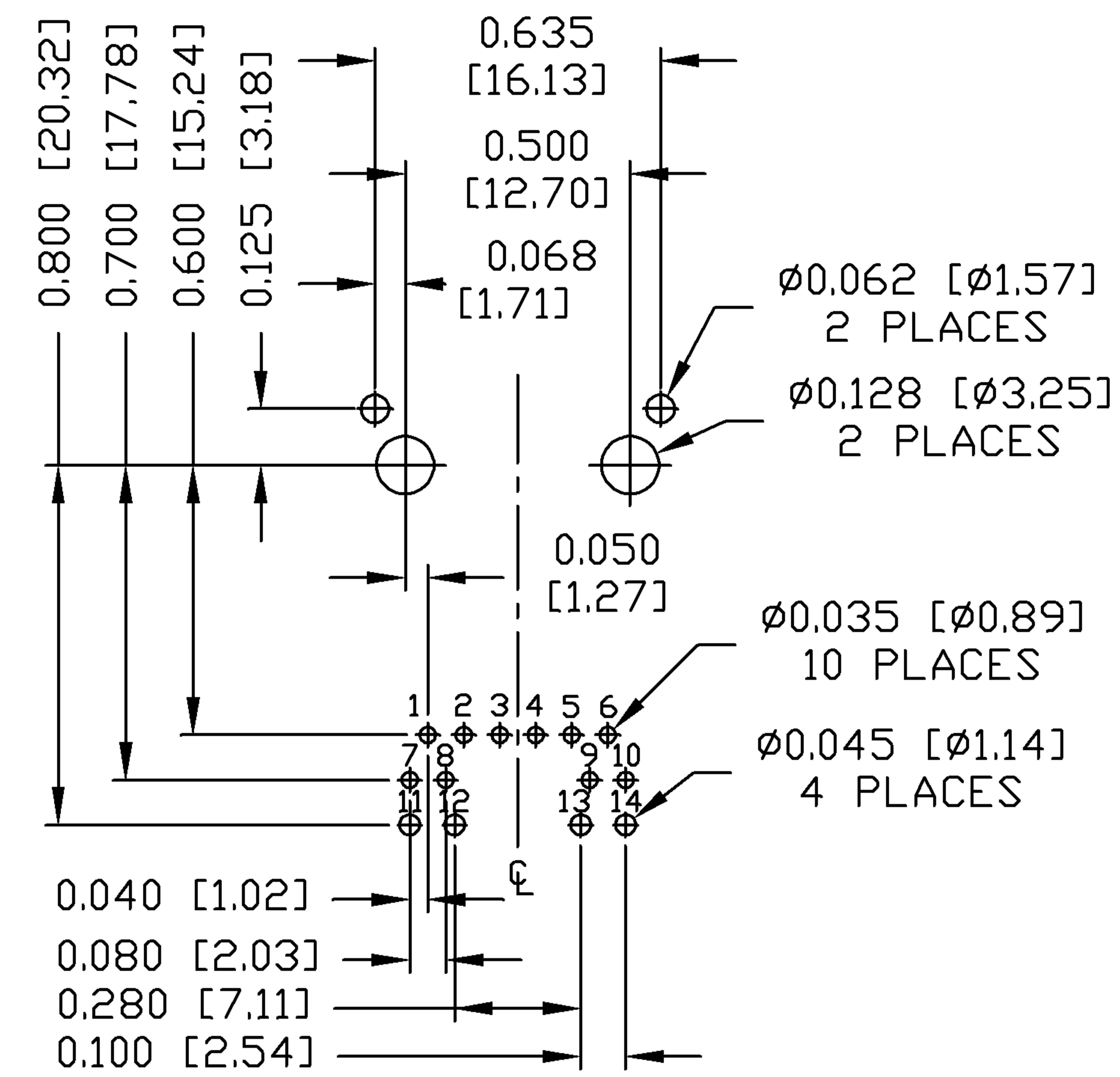
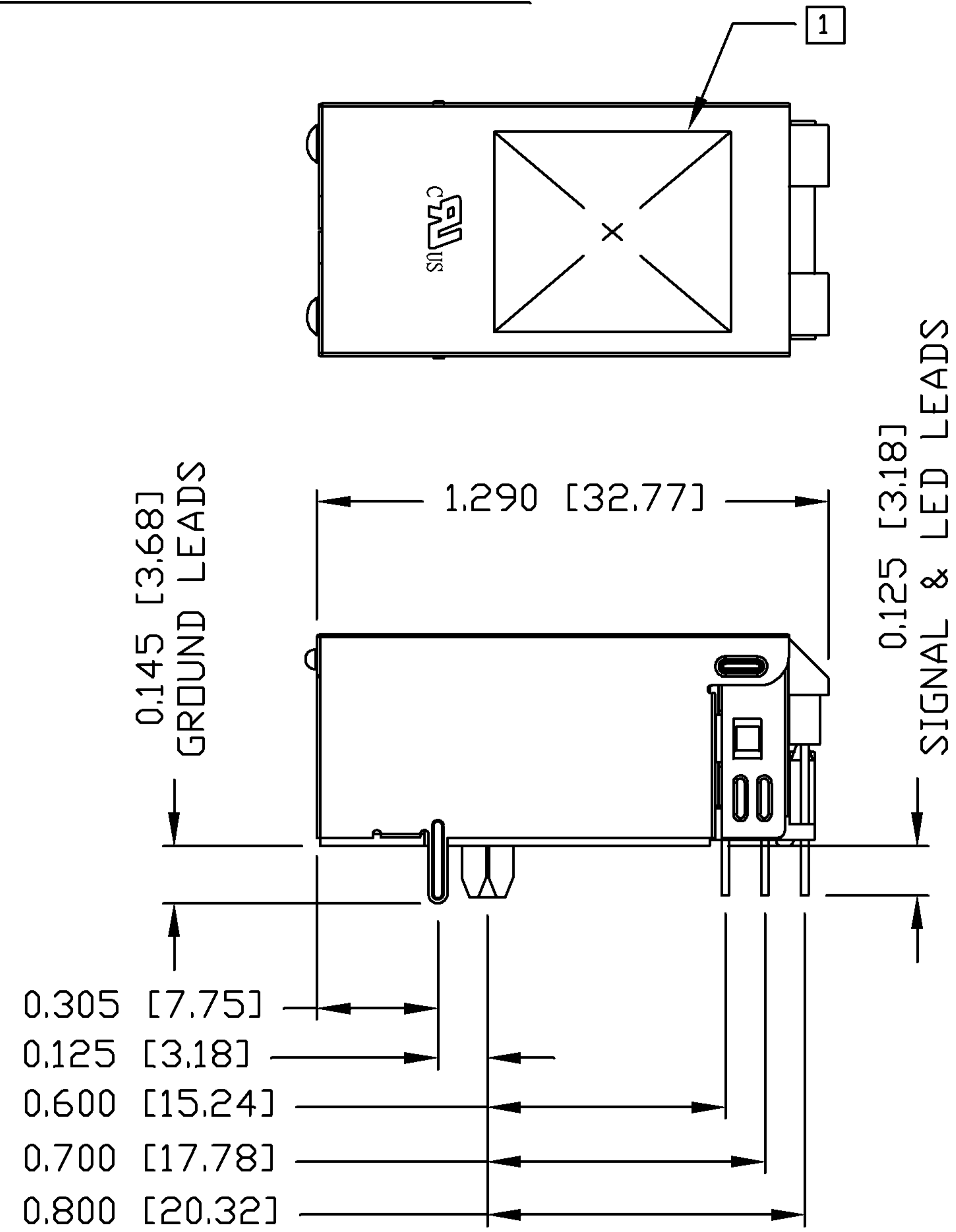
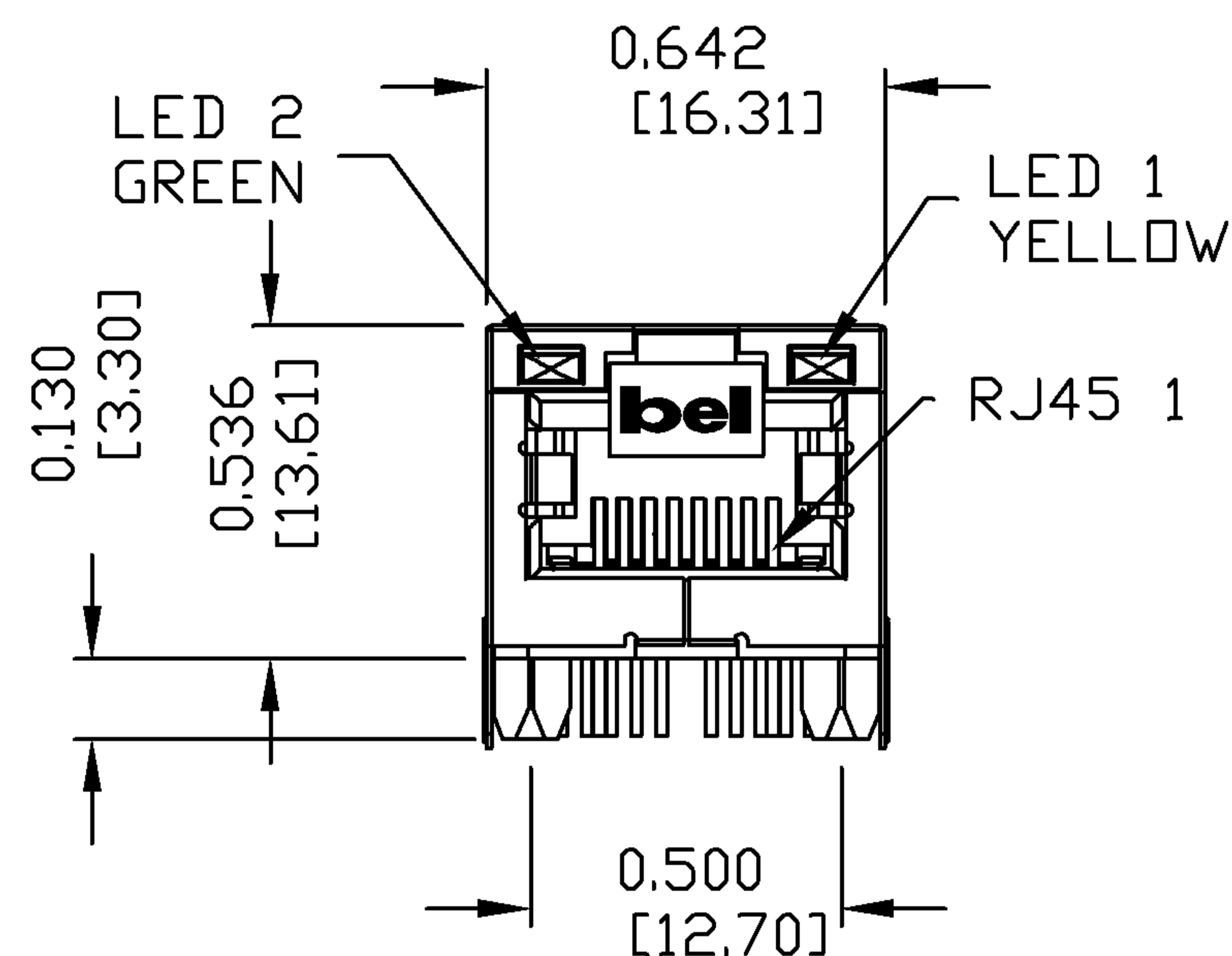

NOTES:

- PLASTIC HOUSING: THERMOPLASTIC PA
FLAMMABILITY RATING UL 94V-0
- CONTACTS: 50 MICRO-INCH HARD GOLD PLATING
- OUTPUT PINS: TIN-COATED COPPER WIRE, DIA 0.018 INCH.
- METAL SHIELD: NICKEL PLATED ON COPPER ALLOY.
(ALL GROUND LEADS ARE SOLDER DIPPED)

1. MARK PART WITH MFG LOGO, MFG NAME, PART NUMBER, AND DATE CODE.

2. RoHS COMPLIANCE, PER EU DIRECTIVE 2002/95/EC.
JACK CAVITY CONFORMS TO FCC RULES AND REGULATIONS.

ORIGINATED BY ZX HUANG	DATE 07-31-08	TITLE MagJack® (Dual Stuff Option, Tab Up)	PART NO. / DRAWING NO. 08261AX147-F	STANDARD DIM. TOL. IN INCH	[] METRIC DIM. AS REFERENCE	 COMPONENTS FOR A CONNECTED PLANET
DRAWN BY BL CHEN	DATE 07-31-08		FILE NAME 08261AX147-F_C.DWG	.X	UNIT : INCH [mm]	
			.XX	SCALE : N/A	SIZE : A4	
			.XXX	±0.010	PAGE : 3	

THE INFORMATION CONTAINED HEREIN IS CONSIDERED "PROPRIETARY" TO BEL FUSE INC. AND SHALL NOT BE COPIED, REPRODUCED OR DISCLOSED WITHOUT THE WRITTEN APPROVAL OF BEL FUSE INC.

RoHS
2002/95/EC

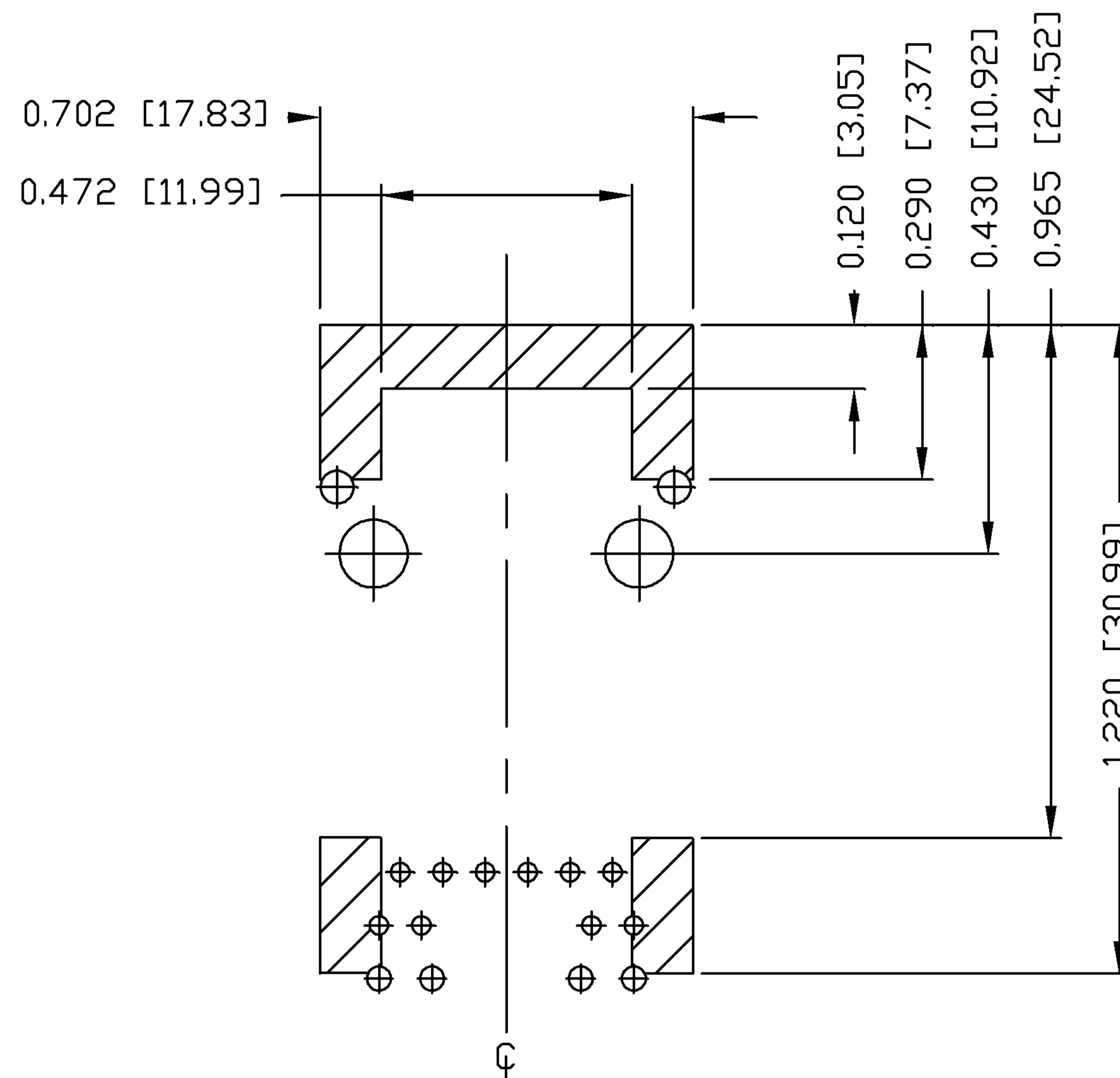

NOTES

THE SHADED AREA ON THE CUSTOMER BOARD ARE RECOMMENDED TO BE CLEAR OFF ANY VIA HOLE OR COMPONENT PAD.

ORIGINATED BY ZX HUANG	DATE 07-31-08	TITLE MagJack® (Dual Stuff Option, Tab Up)	PART NO. / DRAWING NO. 08261AX147-F	STANDARD DIM. TOL. IN INCH	[] METRIC DIM. AS REFERENCE	
DRAWN BY BL CHEN	DATE 07-31-08		FILE NAME 08261AX147-F_C.DWG	.X .XX .XXX	±0.004	UNIT : INCH [mm] SCALE : N/A



THE INFORMATION CONTAINED HEREIN IS CONSIDERED "PROPRIETARY" TO BEL FUSE INC. AND SHALL NOT BE COPIED, REPRODUCED OR DISCLOSED WITHOUT THE WRITTEN APPROVAL OF BEL FUSE INC.

RoHS
2002/95/EC

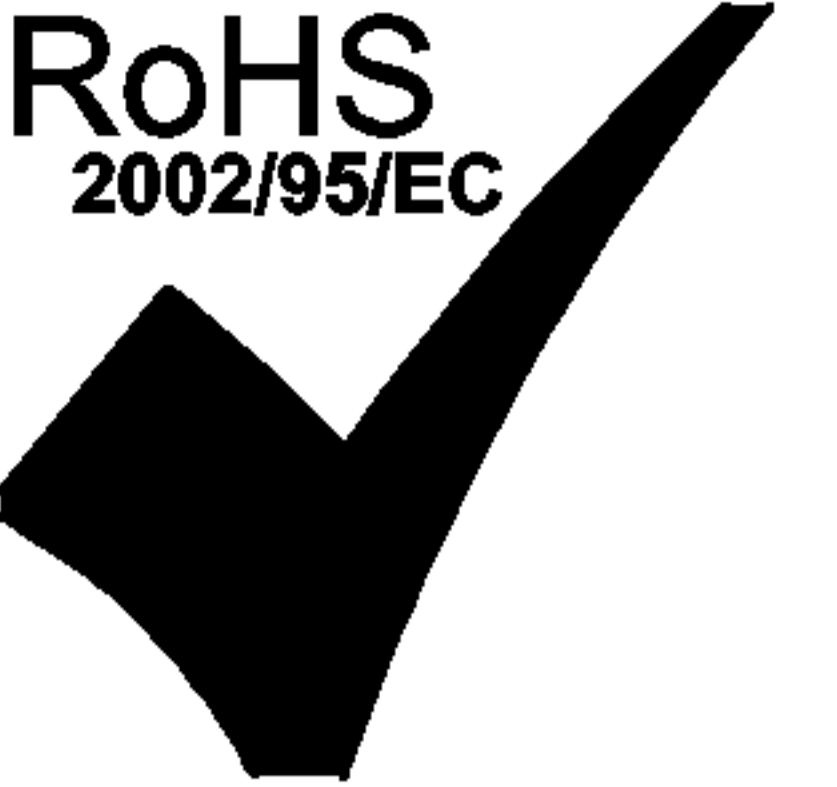

SUGGESTED PANEL OPENING

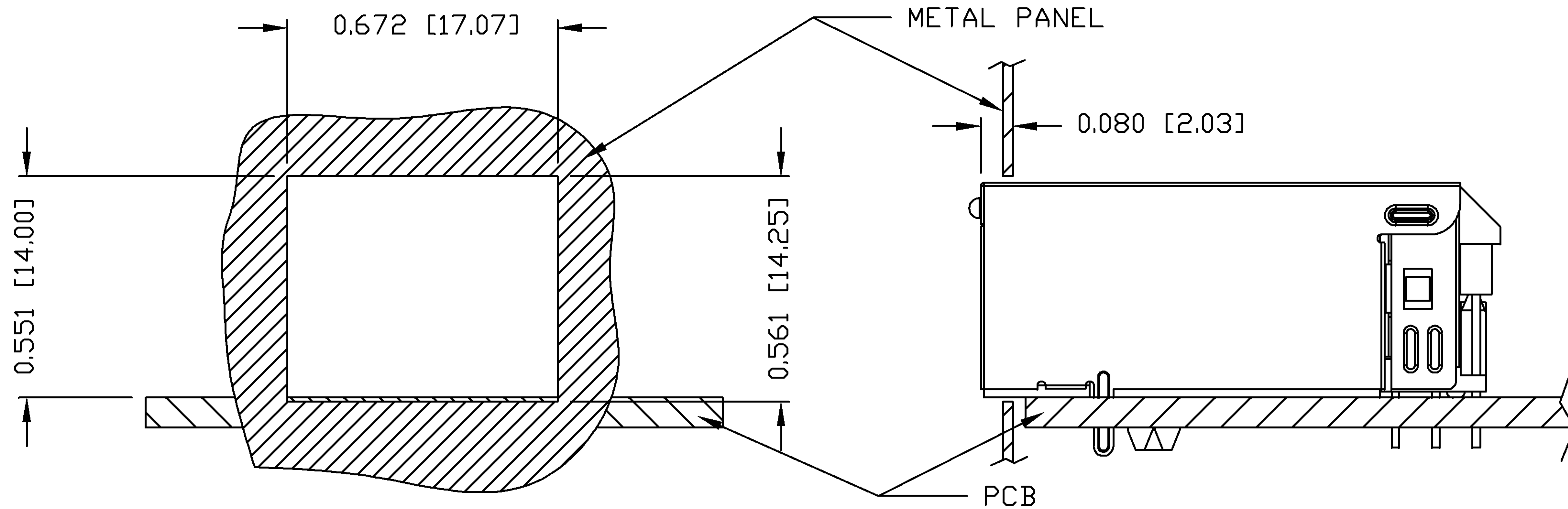

NOTE:

THE DISTANCE OF PANEL INSIDE SURFACE RELATIVE TO FRONT SURFACE OF PART IS ONLY A SUGGESTION. IN CASE THIS DISTANCE IS DIFFERENT, THE REQUIRED PANEL OPENING DIMENSIONS CHANGE ACCORDINGLY.

PACKING INFORMATION

PACKING TRAY : 0200-9999-F6 (TOP)
0200-9999-F7 (BOTTOM)

PACKING QUANTITY : 40 PCS FINISHED GOODS PER TRAY
10 TRAYS (400 PCS FINISHED GOODS) PER CARTON BOX

NOTE : CARDBOARDS ARE PLACED BETWEEN LAYERS OF PACKING TRAY INSIDE CARTON BOX
(INCLUDE THE UPPERMOST AND LOWERMOST TRAY)

ORIGINATED BY ZX HUANG	DATE 07-31-08	TITLE MagJack® (Dual Stuff Option, Tab Up)	PART NO. / DRAWING NO. 08261AX147-F	STANDARD DIM. TOL. IN INCH	[] METRIC DIM. AS REFERENCE	
	DRAWN BY BL CHEN		DATE 07-31-08	FILE NAME 08261AX147-F_C.DWG	.X	UNIT : INCH [mm]
				.XX	SCALE : N/A	SIZE : A4
				.XXX ±0.004		PAGE : 5

