

MAAM26100-P1

GaAs MMIC Power Amplifier 2.0 - 6.0 GHz

Rev. V7

Features

- Saturated Output Power: 30.5 dBm Typical
- Gain: 20 dB Typical
- Power Added Efficiency: 30% Typical
- On-Chip Bias Network
- DC Decoupled RF Input and Output
- Lead-Free High Performance Ceramic Package
- RoHS* Compliant and 260°C Reflow Compatible

Description

The MAAM26100-P1 is a GaAs MMIC two stage high efficiency power amplifier in a lead-free high performance bolt down ceramic package. The MAAM26100-P1 is a fully monolithic design which eliminates the need for external circuitry in 50-ohm systems.

The MAAM26100-P1 is ideally suited for driver amplifiers and transmitter outputs in UMTS applications, test equipment, electronic warfare jammers, missile subsystems and phased array radars.

The MAAM26100-P1 is fabricated using a mature 0.5-micron gate length GaAs process. The process features full passivation for increased performance reliability.

Ordering Information

Part Number	Package
MAAM26100-P1	Ceramic Bolt Down

Functional Diagram

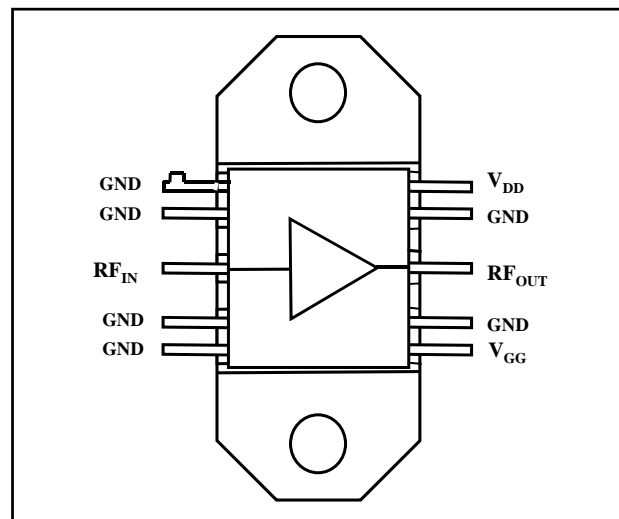

Pin Configuration

Pin No.	Function	Pin No.	Function
1	GND	6	V _{DD}
2	GND	7	GND
3	RF _{IN}	8	RF _{OUT}
4	GND	9	GND
5	GND	10	V _{DD}

Absolute Maximum Ratings^{1,2}

Parameter	Absolute Maximum
V _{DD}	+9 V
V _{GG}	-6 V to -3 V
RF Input Power	+17 dBm
Channel Temperature	150°C
Storage Temperature	-65°C to +150°C
Thermal Resistance (Channel to Case)	15°C/W

1. Exceeding any one or combination of these limits may cause permanent damage to this device and will void product warranty.
2. M/A-COM does not recommend sustained operation near these survivability limits.

* Restrictions on Hazardous Substances, European Union Directive 2002/95/EC.

Lead-Free CR-15[†]

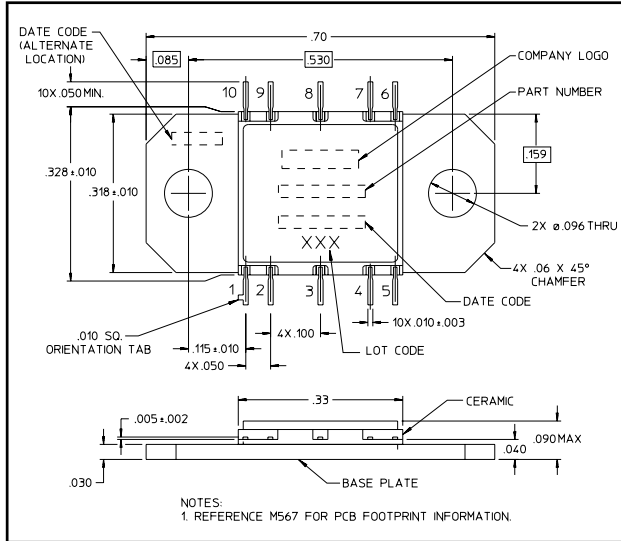

[†] Reference Application Note M538 for lead-free solder reflow recommendations.
Meets JEDEC moisture sensitivity level 1 requirements.

Functional Schematic^{3,4}

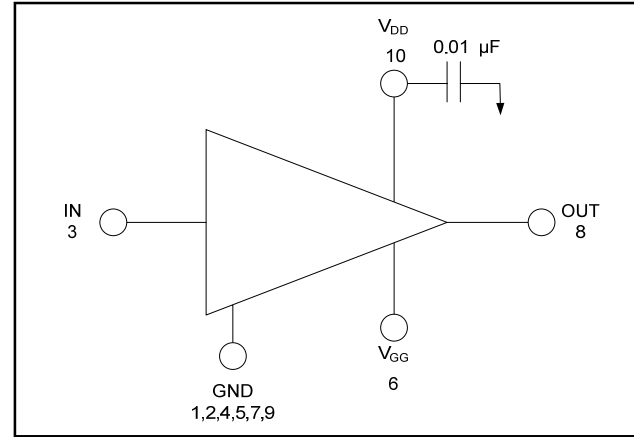

- Nominal bias is obtained by first connecting -5 volts to pin 6 (V_{GG}), followed by connecting +8 volts to pin 10 (V_{DD}). Note sequence.
- RF ground and thermal interface is the flange (case bottom). Adequate heat sinking is required.

Electrical Specifications: T_A = 25°C, V_{DD} = +8 V, V_{GG} = -5 V

Parameter	Test Conditions	Units	Min.	Typ.	Max.
Small Signal Gain	Pin ≤ -10 dBm, 2-6 GHz	dB	—	20	—
Input VSWR	Pin ≤ -10 dBm, 2-6 GHz	Ratio	—	1.8:1	2.1:1
Output VSWR	Pin ≤ -10 dBm, 2-6 GHz	Ratio	—	2.2:1	—
Output Power	Pin = +14 dBm, 2-6 GHz	dBm	29	30.5	—
P1dB	2-6 GHz	dBm	—	28	—
Power Added Efficiency	Pin = +14 dBm, 2-6 GHz	%	—	30	—
Output IP3	2-6 GHz	dBm	—	40	—
IDS	Pin = +14 dBm, 2-6 GHz	mA	—	475	650

Typical Performance Curves

Gain

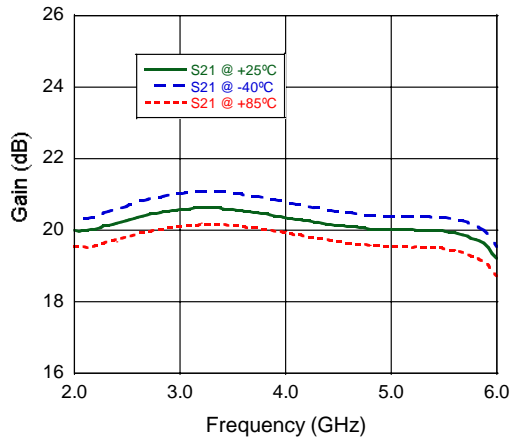

Pout

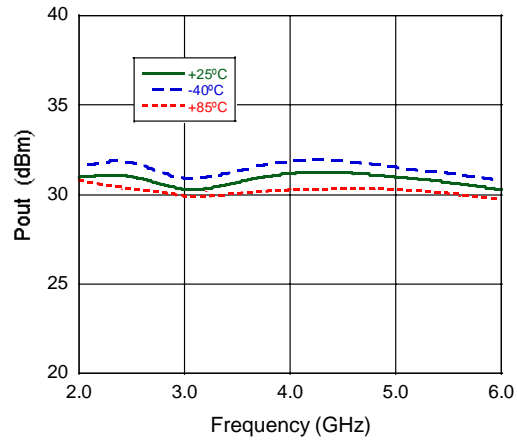

Input Return Loss

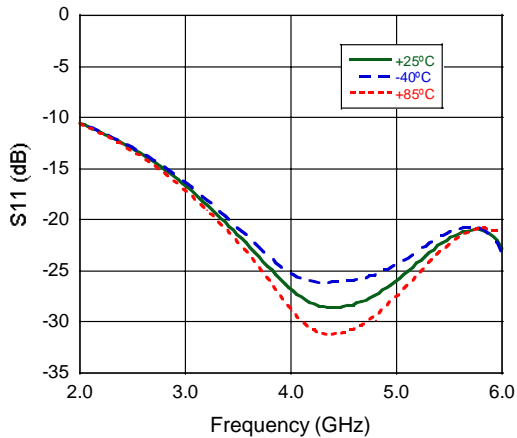

Output Return Loss

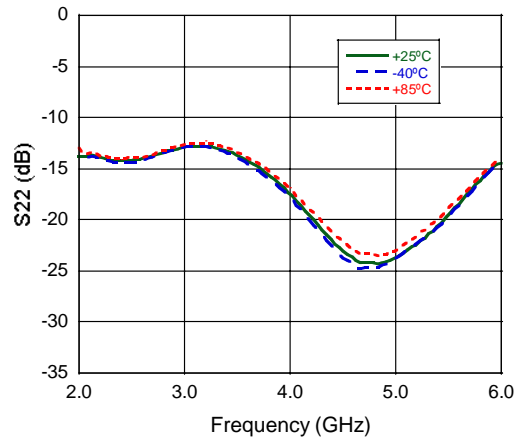

Power Added Efficiency

