

2.0-22.0 GHz GaAs MMIC Power Amplifier

Features

- ✕ Ultra Wide Band Power Amplifier
- ✕ Compact Size/Self Bias Architecture
- ✕ Positive Gain Slope
- ✕ 9.0 dB Small Signal Gain
- ✕ +30.0 dBm P1dB Compression Point
- ✕ +37.0 dBm Third Order Intercept
- ✕ 100% Visual Inspection to MIL-STD-883 Method 2010

General Description

Mimix Broadband's distributed 2.0-22.0 GHz GaAs MMIC power amplifier has a small signal gain of 9.0 dB with a +30.0 dBm P1dB output compression point. This MMIC uses Mimix Broadband's GaAs PHEMT device model technology, and is based upon electron beam lithography to ensure high repeatability and uniformity. The chip has surface passivation to protect and provide a rugged part with backside via holes and gold metallization to allow either a conductive epoxy or eutectic solder die attach process. This device is well suited for Test Instrumentation, Military, Space, Microwave Point-to-Point Radio, SATCOM and VSAT applications.

Chip Device Layout

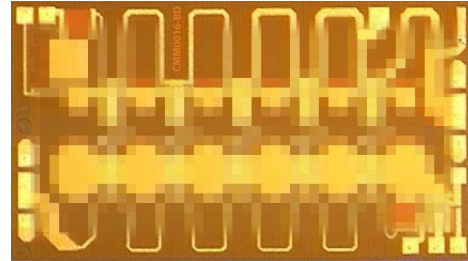

Absolute Maximum Ratings

Supply Voltage (Vd)	+12.0 VDC
Supply Current (Id1)	750 mA
Input Power (Pin)	+27.0 dBm
Storage Temperature (Tstg)	-65 to +165 °C
Operating Temperature (Ta)	-55 to +85 °C
Channel Temperature (Tch) ¹	+175 °C

(1) Channel temperature affects a device's MTTF. It is recommended to keep channel temperature as low as possible for maximum life.

Electrical Characteristics (Ambient Temperature T = 25 °C)

Parameter	Units	Min.	Typ.	Max.
Frequency Range (f)	GHz	2.0	-	22.0
Input Return Loss (S11)	dB	8.0	15.0	-
Output Return Loss (S22)	dB	5.0	10.0	-
Small Signal Gain (S21)	dB	6.0	9.0	-
Gain Flatness ($\Delta S21$)	dB	-	+/-1.5	-
Reverse Isolation (S12)	dB	-	40.0	-
Output Power for 1dB Compression (P1dB) @ 18 GHz	dBm	+28.0	+29.0	-
Output Third Order Intermods (OIP3)	dBm	-	+37.0	-
Saturated Output Power (Psat)	dBm	-	+30.0	-
Drain Bias Voltage (Vd)	VDC	-	+11.5	+11.8
Supply Current (Id) (Vd=12.0V Typical)	mA	-	690	730

100% on-wafer DC testing and 100% RF wafer qualification. Wafer qualification includes sample testing from each quadrant with an 80% pass rate required.

2.0-22.0 GHz GaAs MMIC Power Amplifier



September 2009 - Rev 14-Sep-09

CMM0016-BD

Power Amplifier Measurements (On Wafer)

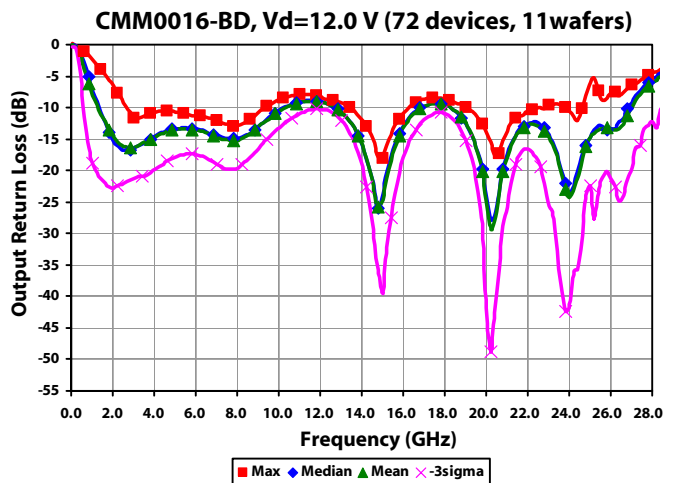
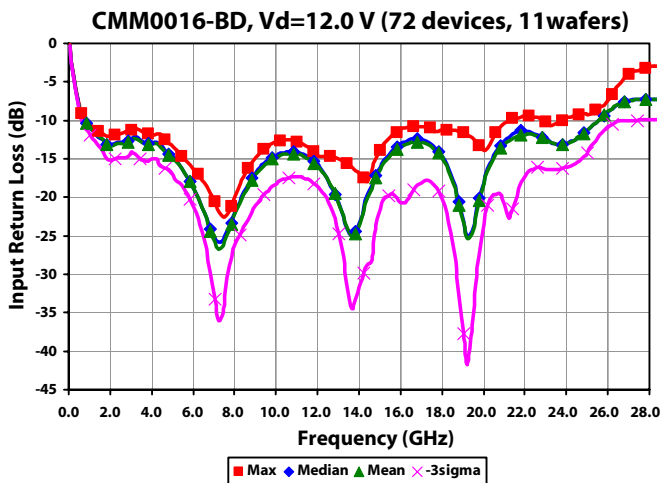
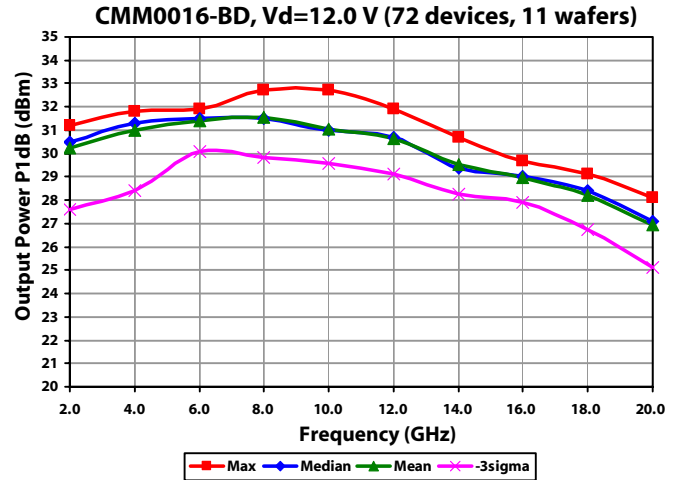
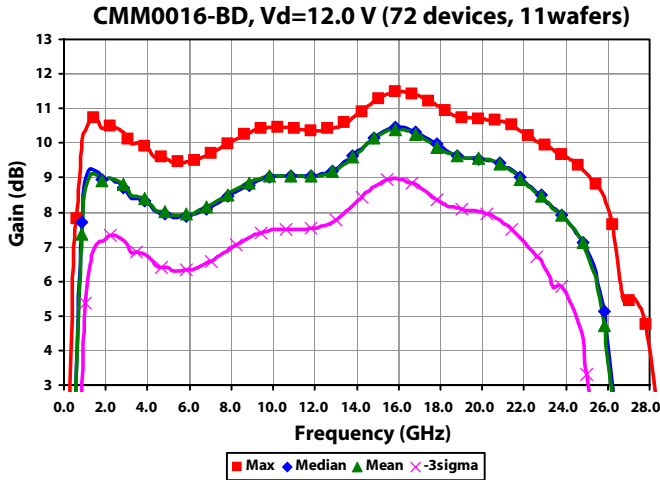

2.0-22.0 GHz GaAs MMIC Power Amplifier



September 2009 - Rev 14-Sep-09

CMM0016-BD

Power Amplifier Measurements (Test Fixture)

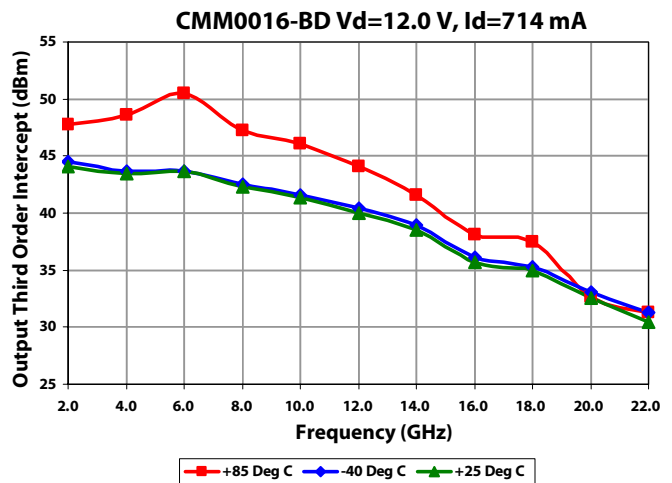
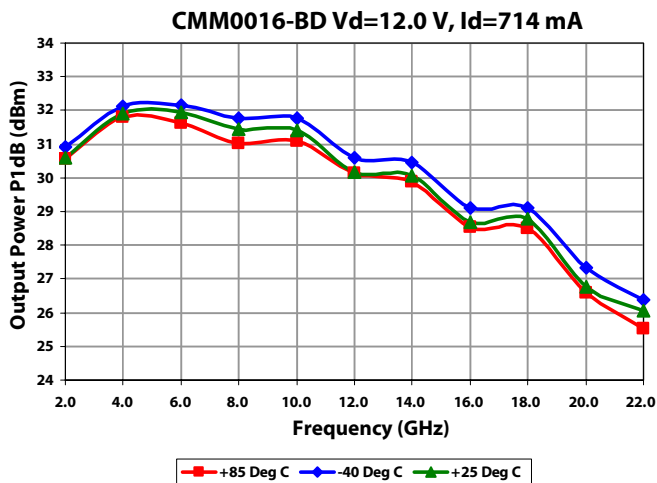
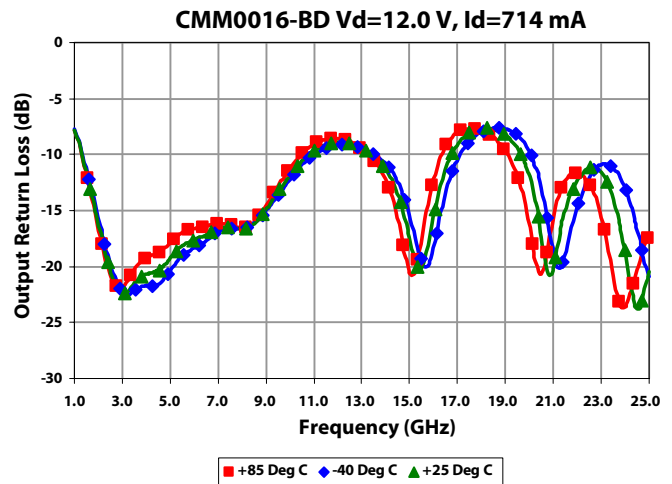
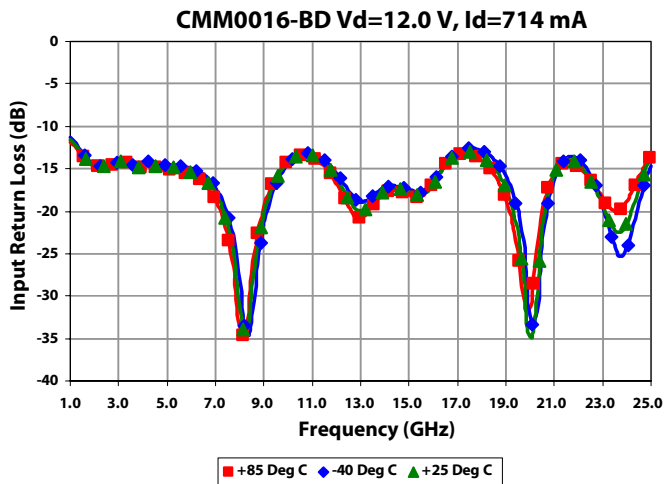
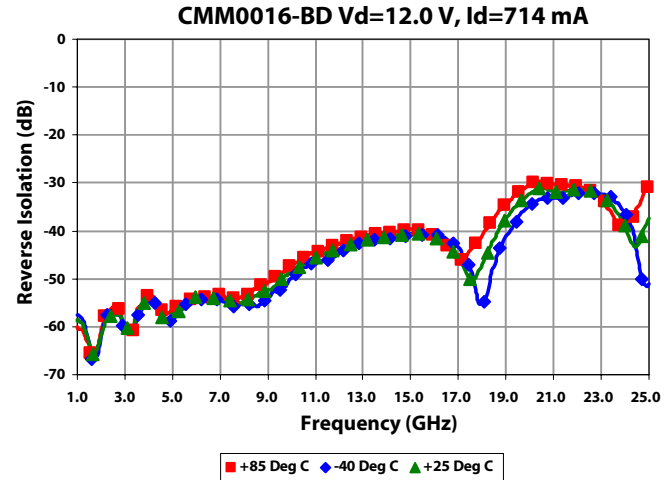
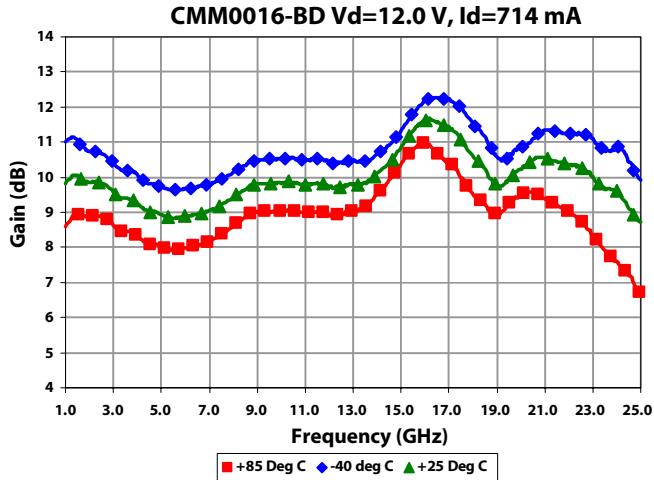

Mimix Broadband, Inc., 10795 Rockley Rd., Houston, Texas 77099
 Tel: 281.988.4600 Fax: 281.988.4615 mimixbroadband.com

Page 3 of 9

Characteristic Data and Specifications are subject to change without notice. ©2009 Mimix Broadband, Inc.
 Export of this item may require appropriate export licensing from the U.S. Government. In purchasing these parts, U.S. Domestic customers accept their obligation to be compliant with U.S. Export Laws.

2.0-22.0 GHz GaAs MMIC Power Amplifier



September 2009 - Rev 14-Sep-09

CMM0016-BD

Power Amplifier Measurements (Test Fixture, cont.)

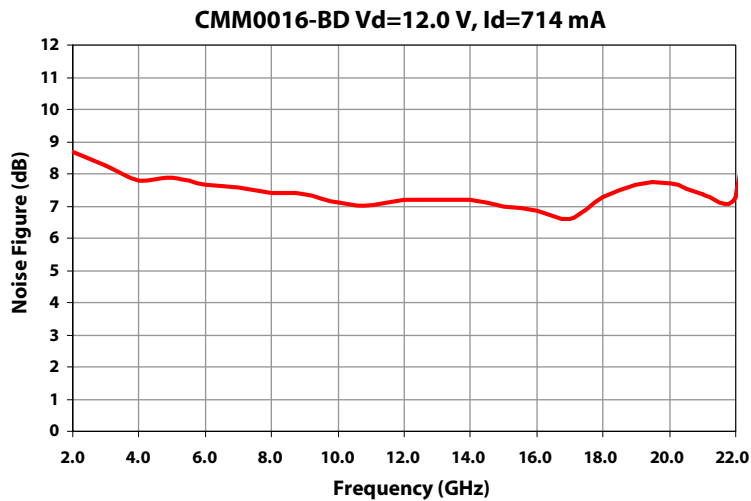
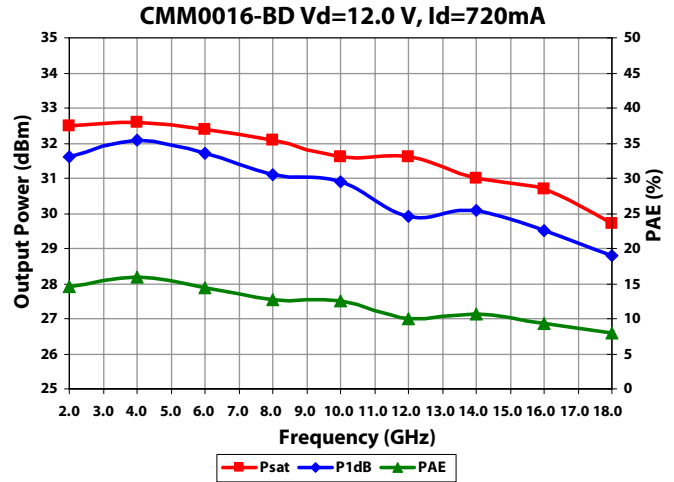
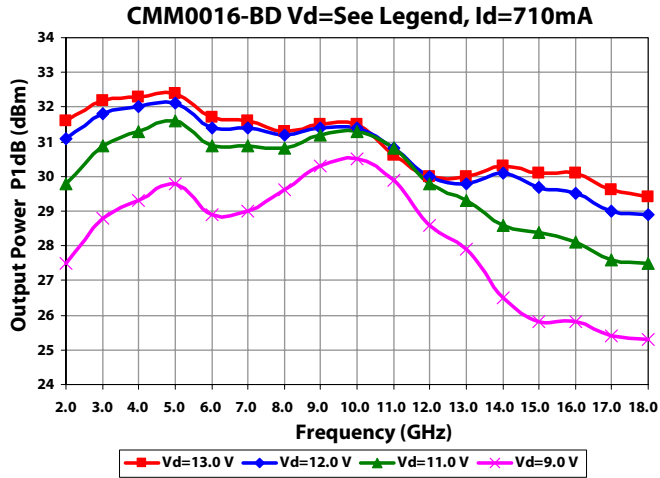

2.0-22.0 GHz GaAs MMIC Power Amplifier



September 2009 - Rev 14-Sep-09

CMM0016-BD

S-Parameters

Typical S-Parameter Data for CMM0016

Vd=12.0 V Id=640 mA

Frequency (GHz)	S11 (Mag)	S11 (Ang)	S21 (Mag)	S21 (Ang)	S12 (Mag)	S12 (Ang)	S22 (Mag)	S22 (Ang)
1.0	0.277	-86.22	2.700	-167.46	0.0011	24.77	0.402	166.03
2.0	0.202	-114.02	2.725	131.47	0.0008	124.31	0.147	152.40
3.0	0.235	-140.08	2.645	89.13	0.0006	-95.30	0.116	-168.17
4.0	0.225	-169.69	2.536	52.78	0.0011	79.41	0.168	-155.84
5.0	0.168	154.38	2.453	20.65	0.0005	9.05	0.204	-160.17
6.0	0.115	119.26	2.453	-11.31	0.0002	-33.33	0.211	-167.49
7.0	0.065	58.82	2.520	-43.41	0.0011	30.74	0.191	-170.93
8.0	0.076	-31.58	2.637	-76.90	0.0013	-16.21	0.171	-162.16
9.0	0.126	-83.27	2.763	-112.26	0.0022	-34.08	0.202	-148.77
10.0	0.160	-119.97	2.832	-148.90	0.0022	-72.22	0.277	-150.90
11.0	0.166	-154.85	2.842	174.35	0.0040	-98.44	0.336	-165.06
12.0	0.138	165.46	2.836	138.34	0.0044	-126.00	0.346	174.96
13.0	0.095	106.96	2.888	102.63	0.0054	-150.52	0.289	151.55
14.0	0.099	18.87	3.045	65.57	0.0077	177.20	0.157	124.61
15.0	0.156	-43.46	3.256	24.95	0.0096	145.52	0.027	-102.35
16.0	0.199	-85.77	3.345	-19.11	0.0114	105.97	0.204	-122.35
17.0	0.190	-122.61	3.261	-64.12	0.0128	69.02	0.307	-155.45
18.0	0.121	-157.92	3.094	-108.40	0.0141	30.63	0.305	169.38
19.0	0.011	-89.57	2.971	-152.23	0.0153	-10.25	0.199	128.80
20.0	0.137	-61.09	2.932	161.48	0.0169	-52.15	0.057	42.60
21.0	0.216	-95.04	2.845	111.18	0.0194	-96.40	0.137	-91.36
22.0	0.219	-123.04	2.665	58.20	0.0220	-143.49	0.188	-145.34
23.0	0.181	-135.46	2.468	1.94	0.0247	166.00	0.101	158.26
24.0	0.196	-133.77	2.270	-60.35	0.0264	114.24	0.072	-48.60
25.0	0.266	-144.09	1.925	-136.84	0.0245	43.15	0.120	-146.55
26.0	0.388	-174.12	0.993	137.06	0.0120	-31.63	0.228	38.54
27.0	0.435	148.26	0.358	74.90	0.0048	-96.22	0.456	-23.95
28.0	0.456	116.28	0.135	32.09	0.0023	147.48	0.594	-56.07
29.0	0.490	87.59	0.057	0.93	0.0060	102.78	0.671	-78.32
30.0	0.538	62.52	0.025	-23.91	0.0064	62.69	0.702	-95.14
31.0	0.589	39.86	0.010	-41.96	0.0055	56.95	0.703	-108.90
32.0	0.635	18.78	0.005	-2.88	0.0048	41.23	0.647	-120.49
33.0	0.643	-0.20	0.009	-24.55	0.0117	-12.72	0.550	-116.59
34.0	0.618	-14.06	0.004	-21.04	0.0038	4.26	0.623	-122.62
35.0	0.593	-23.41	0.011	-19.35	0.0114	-21.10	0.630	-125.65
36.0	0.586	-28.93	0.011	-77.84	0.0087	-78.46	0.635	-128.10
37.0	0.606	-34.32	0.007	-79.49	0.0077	-78.03	0.685	-130.31
38.0	0.636	-38.06	0.009	-140.13	0.0076	-124.86	0.737	-134.38
39.0	0.670	-43.97	0.006	-148.42	0.0061	-145.44	0.775	-139.28
40.0	0.700	-49.43	0.000	74.12	0.0033	-164.12	0.818	-145.44

2.0-22.0 GHz GaAs MMIC Power Amplifier

Mechanical Drawing

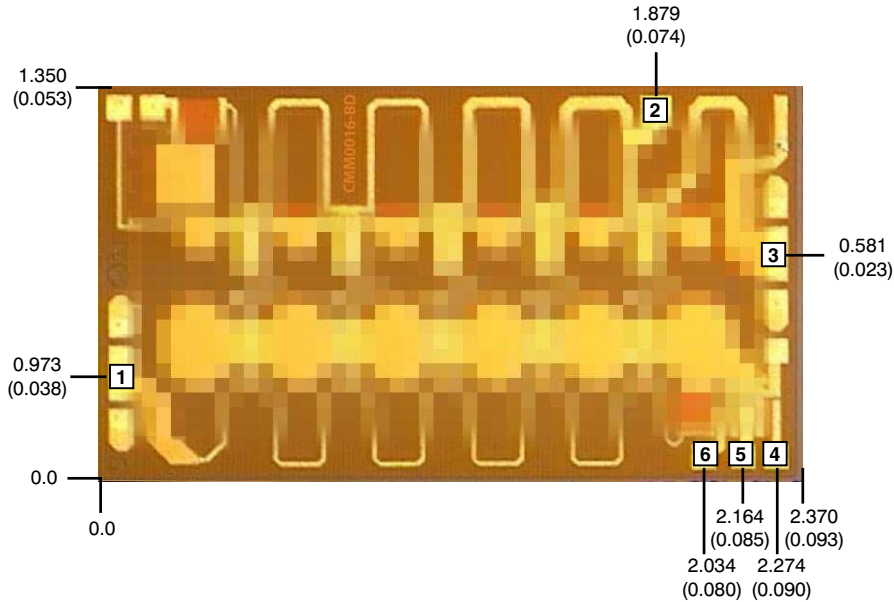

(Note: Engineering designator is M397)

Units: millimeters (inches) Bond pad dimensions are shown to center of bond pad.
 Thickness: 0.110 +/- 0.010 (0.0043 +/- 0.0004), Backside is ground, Bond Pad/Backside Metallization: Gold
 All DC Bond Pads (except Vd3) are 0.100 x 0.100 (0.004 x 0.004). All RF Bond Pads (and Vd3) are 0.100 x 0.200 (0.004 x 0.008)
 Bond pad centers are approximately 0.109 (0.004) from the edge of the chip.
 Dicing tolerance: +/- 0.005 (+/- 0.0002). Approximate weight: 1.984 mg.

Bond Pad #1 (RF In)
 Bond Pad #2 (Vd)

Bond Pad #3 (RF Out)
 Bond Pad #4 (Rs-12.0Ω)

Bond Pad #5 (Rs-1.5Ω)
 Bond Pad #6 (Rs-6.0Ω)

Bias Arrangement

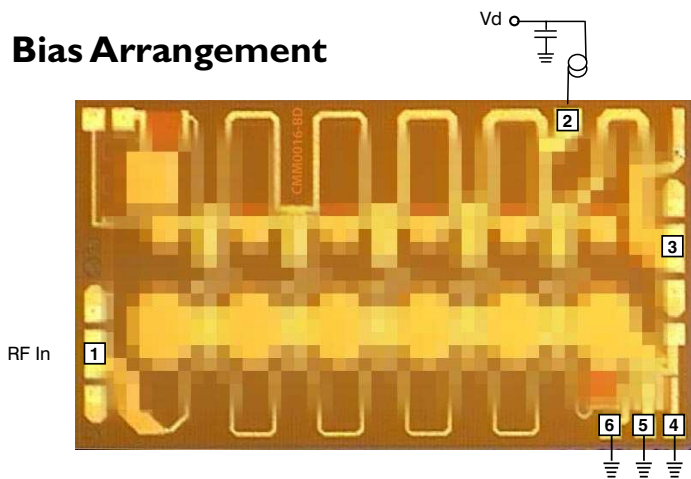

Bypass Capacitors - See App Note [2]

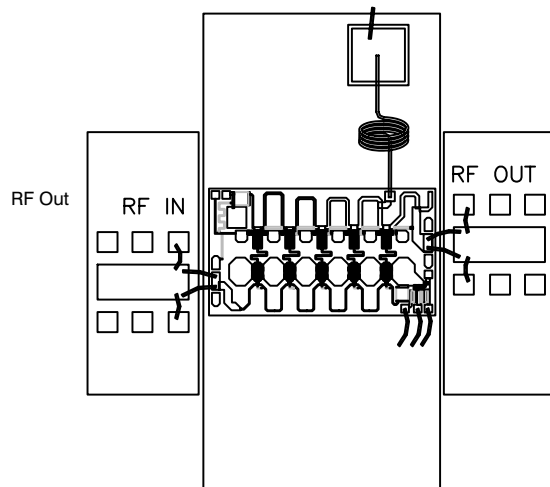

2.0-22.0 GHz GaAs MMIC Power Amplifier

App Note [1] Biasing - As shown in the bonding diagram, this device operates using a self-biased architecture and only requires one drain bias. Bias is nominally $V_d=12V$, $I_d=690$ mA. For additional assistance in setting current via source resistor, see source resistance table below.

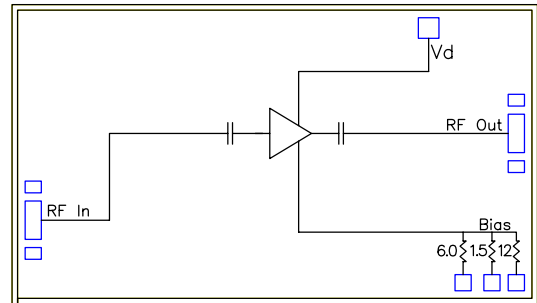

App Note [2] Bias Arrangement - Each DC pad (V_d) needs to have DC bypass capacitance (~100-200 pF) as close to the device as possible. Additional DC bypass capacitance (~0.01 uF) is also recommended. Additionally, to achieve the required broadband decoupling network a high-Q Drain bias inductor with high-Q bypass capacitor is needed. The proper network is necessary in order to bring Drain bias into the device with minimal impact on RF performance. The high-Q inductor is typically an air coil that can be purchased from an air coil manufacturer (Microwave Components or Piconics for example). The air coil needs to have minimum current handling capability, thus planned operating current needs to be defined and considered before defining actual air coil to be used. Mimix recommends 1.4 mil diameter gold wire and 4 turns as a starting point and may need to be optimized based on the actual application. Self-resonance of the bias inductor causes degradation in performance at both the low and high ends of the band. The self resonance is sensitive to spacing between turns and number of turns used. For example, the more turns in the Drain bias inductor the lower the self-resonant frequency of the inductor creating high end RF performance degradation. The opposite is true for a smaller number of turns. In terms of coil attachment to MMIC device (wedge bond tool method), cut coil leads to desired length, use tweezers or wedge bond tip (press on wire to pick up) to place coil for bonding. Make first bond on MMIC die bond pad using wedge bonder tool. Move coil lead as necessary and make second and final bond to bypass capacitor with wedge bond tool using same method as first bond.

Current Select - At times the need to balance performance against system power budgets forces a trade off between bias current, gain, P1dB, or other parameters. This note includes information on how to use the built-in binary bias ladder to adjust the currents enabling this trade off. The bias is controlled by the self bias resistor network in the bottom right corner of the die. These resistors have binary relative values so that you can step the current from a minimum to a maximum with multiple different bias options available along the way. The infinity option is not useful as there is no current flow with all resistors open. Using the information from the current select table shown here allows the user to set the resistors adjusting the current up or down from a nominal value. In addition, the table can be used to estimate how to make a change with minimum trial and error. The net result is that the current can be adjusted over a wide range with incremental control.

CMM0016 - Source Resistance Table

Left	Center	Corner	Net R	Delta Current
				mA
6	1.5	12		
0	0	0	Infinity	NA
0	0	1	12.00	-550
1	0	0	6.00	-475
1	0	1	4.00	-400
0	1	0	1.50	-150
0	1	1	1.33	-100
1	1	0	1.20	-50
1	1	1	1.09	Max

Bonding Substrate - If you are concerned about dialing in the exact current or making fine adjustments to the bias point it is recommended that a bonding substrate, like the one shown here, be used. The purpose is to allow the chip to substrate wire bonds to be left intact and not to be used for adjustments. The bond wires that go from the substrate to ground are then added or subtracted to tune the bias as necessary.

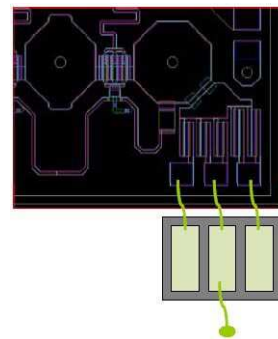

App Note [3] Material Stack-Up - In addition to the practical aspects of bias and bias arrangement, device base material stack-up also must be considered for best thermal performance. A well thought out thermal path solution will improve overall device reliability, RF performance and power added efficiency. The photo shows a typical high power amplifier carrier assembly. The material stack-up for this carrier is shown below. This stack-up is highly recommended for most reliable performance however, other materials (i.e. eutectic solder vs epoxy, copper tungsten/copper moly rib, etc.) can be considered/possibly used but only after careful review of material thermal properties, material availability and end application performance requirements.

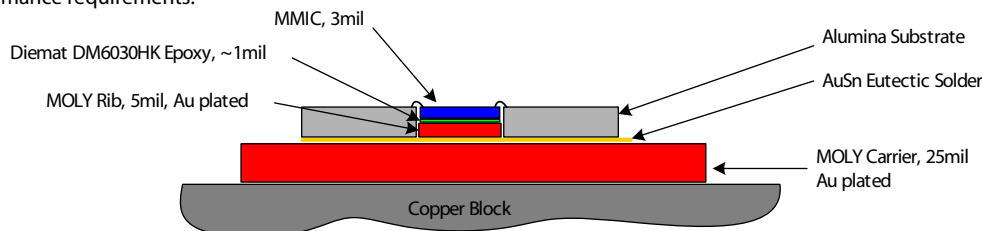

2.0-22.0 GHz GaAs MMIC Power Amplifier



September 2009 - Rev 14-Sep-09

CMM0016-BD

MTTF Graphs

These numbers were calculated based upon accelerated life test information received from the fabricating foundry and extensive thermal modeling/finite element analysis done at Mimix Broadband. The values shown here are only to be used as a guideline against the end application requirements and only represent reliability information under one bias condition. Ultimately bias conditions and resulting power dissipation along with the practical aspects, i.e. thermal material stack-up, attach method of die placement are the key parts in determining overall reliability for a specific application, see previous pages. If the data shown below does not meet your reliability requirements or if the bias conditions are not within your operating limits please contact technical sales for additional information.

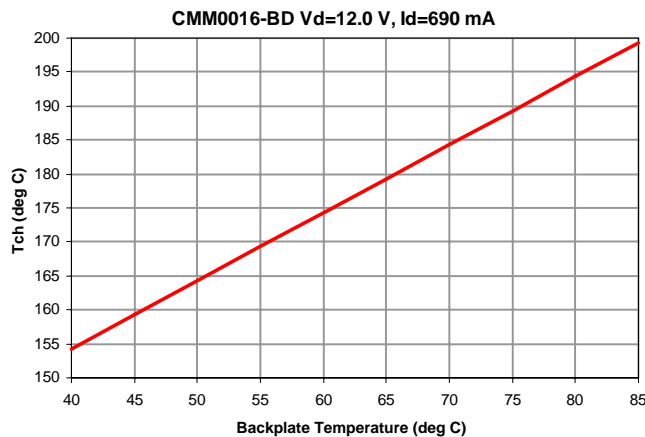
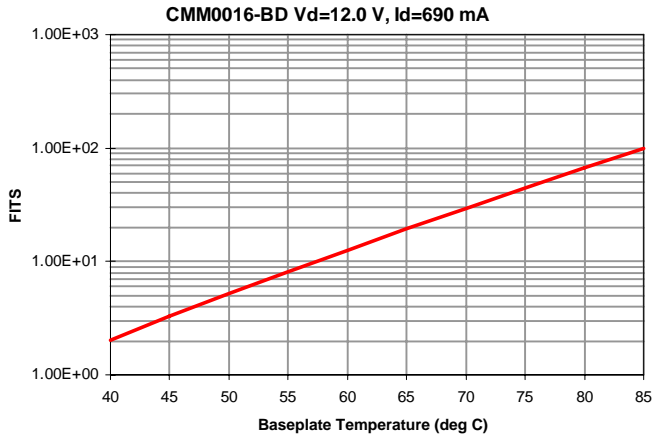
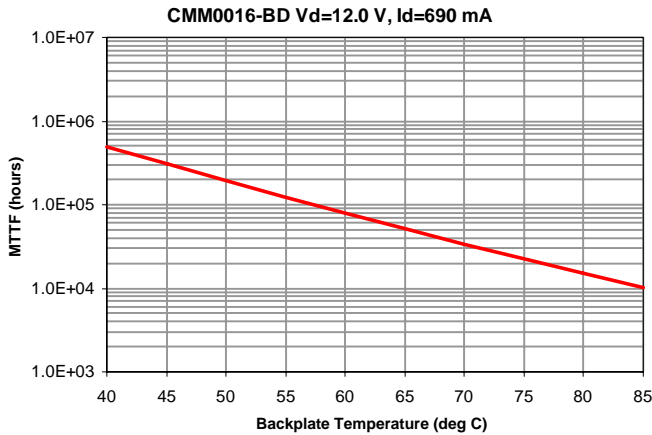

2.0-22.0 GHz GaAs MMIC Power Amplifier

Handling and Assembly Information

CAUTION! - Mimix Broadband MMIC Products contain gallium arsenide (GaAs) which can be hazardous to the human body and the environment. For safety, observe the following procedures:

- *Do not ingest.*
- *Do not alter the form of this product into a gas, powder, or liquid through burning, crushing, or chemical processing as these by-products are dangerous to the human body if inhaled, ingested, or swallowed.*
- *Observe government laws and company regulations when discarding this product. This product must be discarded in accordance with methods specified by applicable hazardous waste procedures.*

Life Support Policy - Mimix Broadband's products are not authorized for use as critical components in life support devices or systems without the express written approval of the President and General Counsel of Mimix Broadband. As used herein: (1) Life support devices or systems are devices or systems which, (a) are intended for surgical implant into the body, or (b) support or sustain life, and whose failure to perform when properly used in accordance with instructions for use provided in the labeling, can be reasonably expected to result in a significant injury to the user. (2) A critical component is any component of a life support device or system whose failure to perform can be reasonably expected to cause the failure of the life support device or system, or to affect its safety or effectiveness.

ESD - Gallium Arsenide (GaAs) devices are susceptible to electrostatic and mechanical damage. Die are supplied in antistatic containers, which should be opened in cleanroom conditions at an appropriately grounded anti-static workstation. Devices need careful handling using correctly designed collets, vacuum pickups or, with care, sharp tweezers.

Die Attachment - GaAs Products from Mimix Broadband are 0.075 mm (0.003") thick and have vias through to the backside to enable grounding to the circuit. Microstrip substrates should be brought as close to the die as possible. The mounting surface should be clean and flat. If using conductive epoxy, recommended epoxy is Die Mat DM6030HK or an epoxy with >52 W/m °K thermal conductivity cured in a nitrogen atmosphere per manufacturer's cure schedule. Apply epoxy sparingly to avoid getting any on to the top surface of the die. An epoxy fillet should be visible around the total die periphery. For additional information please see the Mimix "Epoxy Specifications for Bare Die" application note. If eutectic mounting is preferred, then a fluxless gold-tin (AuSn) preform, approximately 0.001 thick, placed between the die and the attachment surface should be used. A die bonder that utilizes a heated collet and provides scrubbing action to ensure total wetting to prevent void formation in a nitrogen atmosphere is recommended. The gold-tin eutectic (80% Au 20% Sn) has a melting point of approximately 280 °C (Note: Gold Germanium should be avoided). The work station temperature should be 310 °C +/- 10 °C. Exposure to these extreme temperatures should be kept to minimum. The collet should be heated, and the die pre-heated to avoid excessive thermal shock. Avoidance of air bridges and force impact are critical during placement.

Wire Bonding - Windows in the surface passivation above the bond pads are provided to allow wire bonding to the die's gold bond pads. The recommended wire bonding procedure uses 0.076 mm x 0.013 mm (0.003" x 0.0005") 99.99% pure gold ribbon with 0.5-2% elongation to minimize RF port bond inductance. Gold 0.025 mm (0.001") diameter wedge or ball bonds are acceptable for DC Bias connections. Aluminum wire should be avoided. Thermo-compression bonding is recommended though thermosonic bonding may be used providing the ultrasonic content of the bond is minimized. Bond force, time and ultrasonics are all critical parameters. Bonds should be made from the bond pads on the die to the package or substrate. All bonds should be as short as possible.

Ordering Information

Part Number for Ordering

CMM0016-BD-000V

PB-CMM0016-BD-0000

Description

RoHS compliant die packed in vacuum release gel packs

CMM0016-BD evaluation module



Caution: ESD Sensitive
Appropriate precautions in handling, packaging
and testing devices must be observed.

Proper ESD procedures should be followed when handling this device.