

# 0.05-50.0 GHz GaAs MMIC Distributed Amplifier

January 2010 - Rev 18-Jan-10

## Features

- ✕ Wide Band Driver Amplifier
- ✕ 9.0 dB Small Signal Gain
- ✕ 5.0 dB Noise Figure
- ✕ 15.0 dB Gain Control
- ✕ +9.0 dBm P1dB Compression Point
- ✕ 100% On-Wafer RF, DC and Output Power Testing
- ✕ 100% Visual Inspection to MIL-STD-883 Method 2010

## General Description

Mimix Broadband's 0.05-50.0 GHz GaAs MMIC distributed amplifier has a small signal gain of 9.0 dB with a noise figure of 5.0 dB across the band. The device also includes 15.0 dB gain control and a +9.0 dBm P1dB compression point. This MMIC uses Mimix Broadband's GaAs PHEMT device model technology, and is based upon electron beam lithography to ensure high repeatability and uniformity. The chip has surface passivation to protect and provide a rugged part with backside via holes and gold metallization to allow either a conductive epoxy or eutectic solder die attach process. This device is well suited for microwave, millimeter-wave and wideband military applications.

## Chip Device Layout

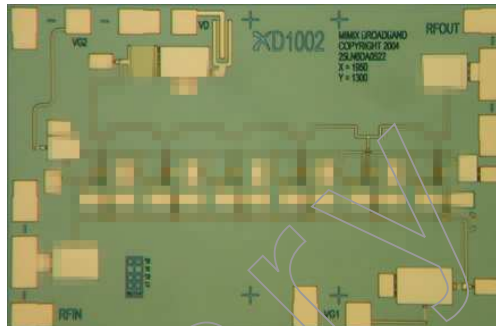

## Absolute Maximum Ratings

Supply Voltage (Vd)	+10.0 VDC
Supply Current (Id)	150 mA
Gate Bias Voltage (Vg1)	+0.3 VDC
Gate Bias Voltage (Vg2)	+3.0 VDC
Input Power (Pin)	+18 dBm
Storage Temperature (Tstg)	-65 to +165 °C
Operating Temperature (Ta)	-55 to +85 °C
Channel Temperature (Tch) <sup>1</sup>	+175 °C

(1) Channel temperature affects a device's MTTF. It is recommended to keep channel temperature as low as possible for maximum life.

## Electrical Characteristics (Ambient Temperature T = 25 °C)

Parameter	Units	Min.	Typ.	Max.
Frequency Range (f)	GHz	0.05	-	50.0
Input Return Loss (S11)	dB	-	14.0	-
Output Return Loss (S22)	dB	-	14.0	-
Small Signal Gain (S21)	dB	-	9.0	-
Gain Flatness ( $\Delta S21$ )	dB	-	+/-1.5	-
Gain Control	dB	-	15.0	-
Reverse Isolation (S12)	dB	-	40.0	-
Noise Figure (NF)	dB	-	5.0	-
Output Power for 1 dB Compression (P1dB) <sup>1</sup>	dBm	-	+9.0	-
Drain Bias Voltage (Vd)	VDC	-	+8.5	+9.0
Gain Control Bias (Vg1)	VDC	-2.0	0.0	+0.1
Gate Bias Voltage (Vg2)	VDC	-	+1.0	-
Supply Current (Id) (Vd=8.5V, Vg1=0.0V, Vg2=1.0V Typical)	mA	-	120	140

(1) Measured using constant current.

# 0.05-50.0 GHz GaAs MMIC Distributed Amplifier

January 2010 - Rev 18-Jan-10

## Distributed Amplifier Measurements (On-Wafer<sup>1</sup>)

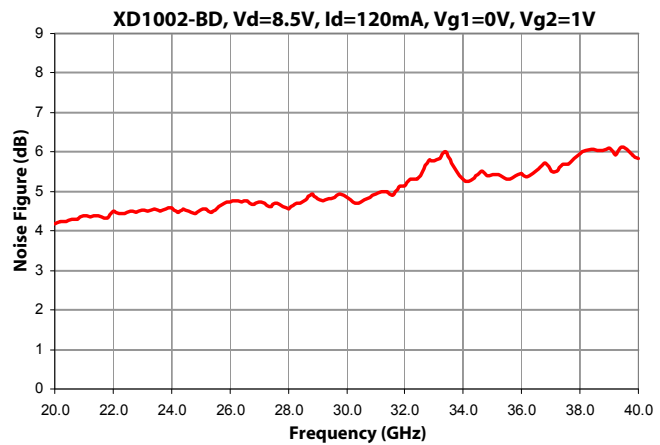
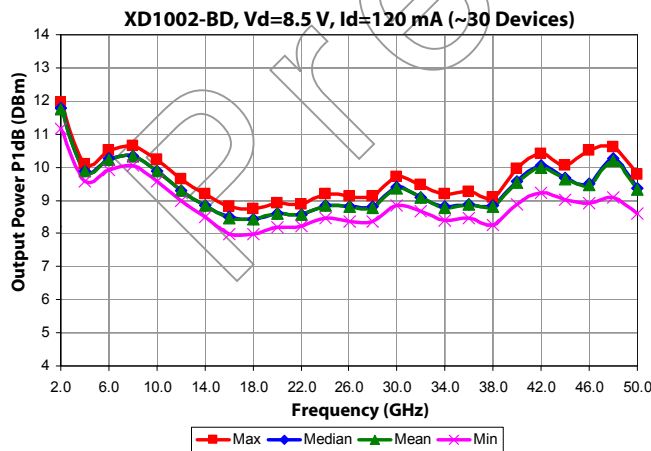
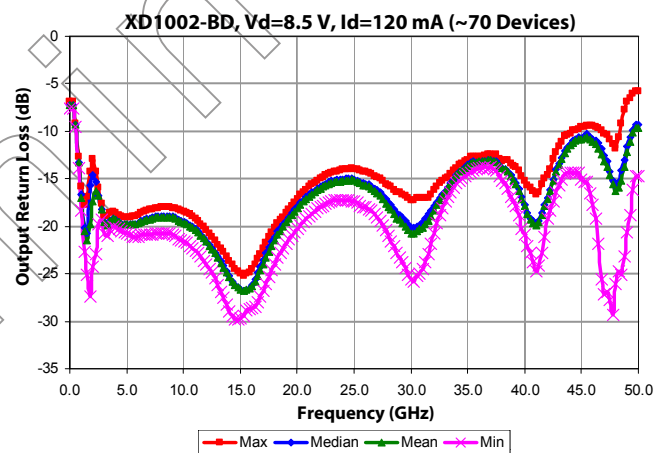
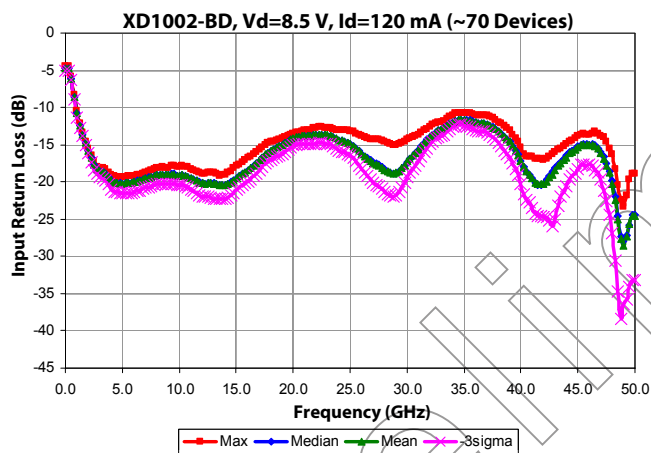
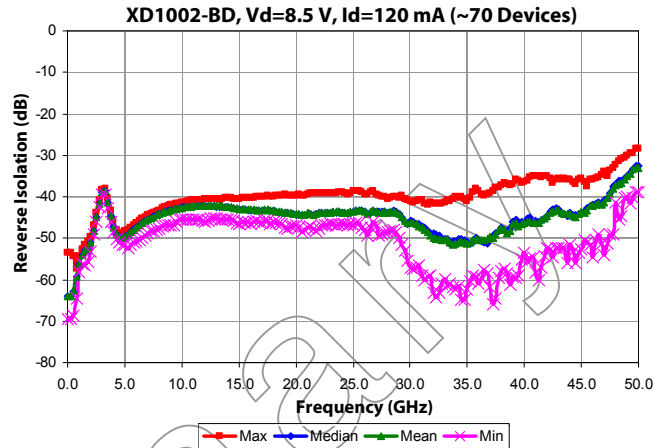
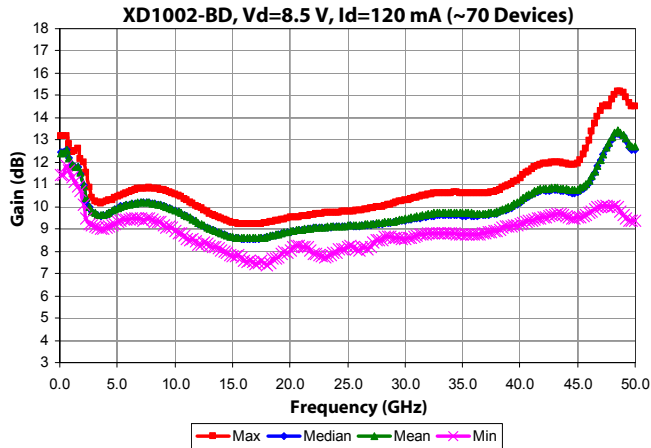

**Note [1] Measurements** – On-Wafer data has been taken using bias conditions as shown. Measurements are referenced 150  $\mu$ m in from RF In/Out pad edge. For optimum performance Mimix T-pad transition is recommended. For additional information see the Mimix “T-Pad Transition” application note.

# 0.05-50.0 GHz GaAs MMIC Distributed Amplifier

January 2010 - Rev 18-Jan-10

## S-Parameters (On-Wafer<sup>1</sup>)

Typical S-Parameter Data for XD1002-BD  
Vd=8.5 V, Id=116 mA

Frequency (GHz)	S11 (Mag)	S11 (Ang)	S21 (Mag)	S21 (Ang)	S12 (Mag)	S12 (Ang)	S22 (Mag)	S22 (Ang)
2.0	0.167	-103.26	3.587	147.99	0.0031	-117.51	0.121	-69.78
3.0	0.113	-109.75	2.859	138.78	0.0128	-157.01	0.108	177.29
4.0	0.099	-120.62	2.832	131.05	0.0041	112.76	0.116	131.77
5.0	0.093	-125.54	2.765	120.66	0.0032	139.64	0.111	87.02
6.0	0.095	-132.47	2.938	108.83	0.0043	136.07	0.115	54.10
7.0	0.101	-142.61	2.921	95.95	0.0054	122.26	0.120	27.59
8.0	0.107	-155.37	2.951	82.80	0.0063	105.77	0.122	5.11
9.0	0.111	-170.50	2.889	69.72	0.0070	88.15	0.119	-14.07
10.0	0.112	171.73	2.880	56.93	0.0075	70.86	0.112	-30.54
11.0	0.110	152.11	2.836	45.22	0.0078	53.61	0.100	-44.61
12.0	0.108	130.11	2.768	33.75	0.0079	36.96	0.085	-55.37
13.0	0.107	106.19	2.715	23.00	0.0078	21.05	0.068	-61.37
14.0	0.108	79.64	2.628	12.68	0.0076	5.77	0.051	-58.73
15.0	0.115	52.78	2.620	3.06	0.0072	-8.21	0.041	-41.60
16.0	0.127	29.20	2.641	-6.63	0.0067	-21.83	0.044	-17.58
17.0	0.140	6.97	2.686	-16.73	0.0066	-33.88	0.061	-5.65
18.0	0.155	-15.07	2.722	-26.98	0.0064	-46.59	0.083	-4.55
19.0	0.169	-35.54	2.772	-37.69	0.0067	-67.28	0.081	-9.49
20.0	0.179	-53.57	2.821	-48.89	0.0059	-77.00	0.125	-15.76
21.0	0.187	-71.02	2.868	-59.87	0.0060	-92.93	0.144	-23.09
22.0	0.189	-90.31	2.905	-71.39	0.0058	-110.88	0.159	-31.60
23.0	0.189	-108.70	2.938	-83.29	0.0056	-129.75	0.168	-39.92
24.0	0.181	-127.23	2.956	-95.25	0.0057	-151.94	0.173	-47.81
25.0	0.169	-148.89	2.951	-107.21	0.0056	-173.35	0.169	-55.49
26.0	0.163	-172.24	2.957	-118.91	0.0057	161.44	0.158	-63.31
27.0	0.154	162.59	2.967	-130.87	0.0055	131.83	0.142	-69.78
28.0	0.153	133.34	2.987	-142.81	0.0052	107.51	0.119	-73.03
29.0	0.159	104.65	2.999	-154.88	0.0050	79.04	0.089	-71.33
30.0	0.173	77.24	3.030	-167.39	0.0049	53.44	0.068	-57.26
31.0	0.194	51.87	3.096	-179.82	0.0046	25.73	0.069	-30.51
32.0	0.208	26.34	3.128	166.27	0.0052	-6.13	0.107	7.94
33.0	0.228	0.99	3.137	152.01	0.0037	-34.08	0.154	-0.41
34.0	0.231	-19.30	3.145	137.76	0.0022	-54.27	0.190	-9.85
35.0	0.212	-39.81	3.118	123.67	0.0016	-68.25	0.215	-20.51
36.0	0.204	-61.85	3.065	110.24	0.0009	-1.89	0.221	-32.35
37.0	0.184	-82.92	3.049	97.55	0.0016	-44.59	0.217	-41.99
38.0	0.157	-114.04	3.090	84.85	0.0022	-24.70	0.200	-53.97
39.0	0.143	-146.18	3.154	72.32	0.0036	-68.01	0.147	-61.25
40.0	0.133	177.51	3.312	58.86	0.0051	-93.58	0.094	-54.25
41.0	0.155	138.78	3.498	43.18	0.0052	-139.38	0.088	-10.69
42.0	0.199	104.26	3.615	25.50	0.0053	175.06	0.169	-0.54
43.0	0.243	73.92	3.575	7.36	0.0047	121.52	0.254	-12.21
44.0	0.262	51.02	3.425	-9.60	0.0031	63.48	0.292	-29.07
45.0	0.257	27.75	3.341	-23.56	0.0030	13.79	0.305	-50.60
46.0	0.232	5.20	3.569	-36.67	0.0024	-62.28	0.271	-77.19
47.0	0.169	-12.83	4.166	-53.59	0.0014	104.29	0.216	-118.49
48.0	0.053	-40.92	4.854	-79.98	0.0101	38.63	0.188	152.21
49.0	0.071	83.22	4.643	-110.82	0.0193	-27.39	0.321	71.51
50.0	0.182	70.43	4.155	-138.60	0.0232	-75.83	0.434	23.40

**Note [1] S-Parameters** – On-Wafer S-Parameters have been taken using bias conditions as shown. Measurements are referenced 150 um in from RF In/Out pad edge.

# 0.05-50.0 GHz GaAs MMIC Distributed Amplifier

January 2010 - Rev I8-Jan-10

## Mechanical Drawing

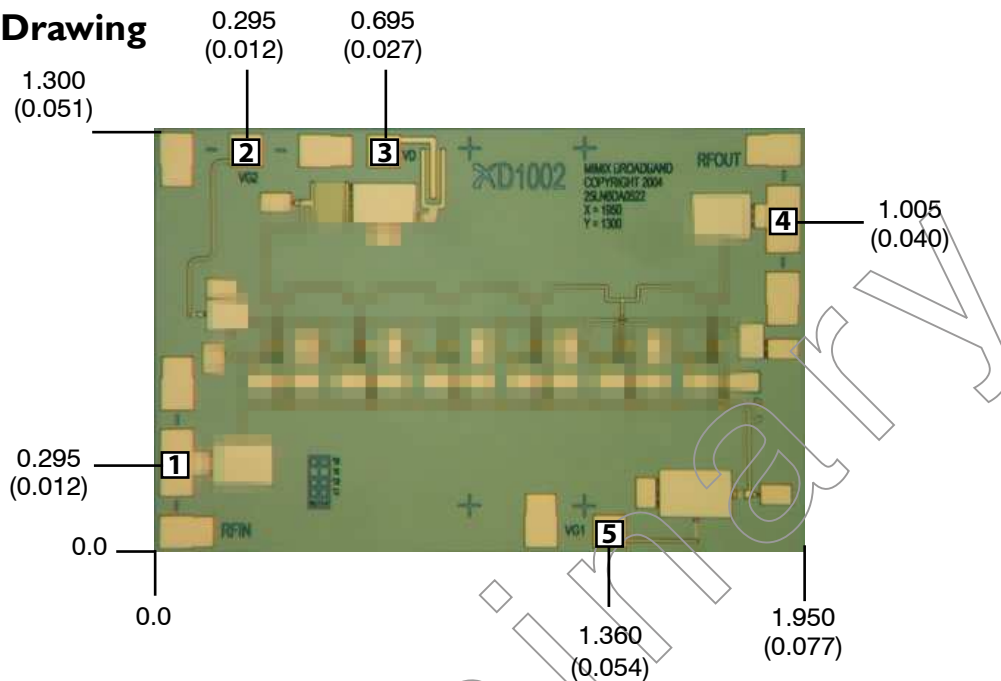

(Note: Engineering designator is 25LN6DA0522)

Units: millimeters (inches) Bond pad dimensions are shown to center of bond pad.  
 Thickness: 0.110 +/- 0.010 (0.0043 +/- 0.0004), Backside is ground, Bond Pad/Backside Metallization: Gold  
 All DC Bond Pads are 0.100 x 0.100 (0.004 x 0.004). All RF Bond Pads are 0.100 x 0.200 (0.004 x 0.008)  
 Bond pad centers are approximately 0.109 (0.004) from the edge of the chip.  
 Dicing tolerance: +/- 0.005 (+/- 0.0002). Approximate weight: 1.417 mg.

Bond Pad #1 (RF In)  
Bond Pad #2 (Vg2)

Bond Pad #3 (Vd)  
Bond Pad #4 (RF Out)

Bond Pad #5 (Vg1)

## Bias Arrangement

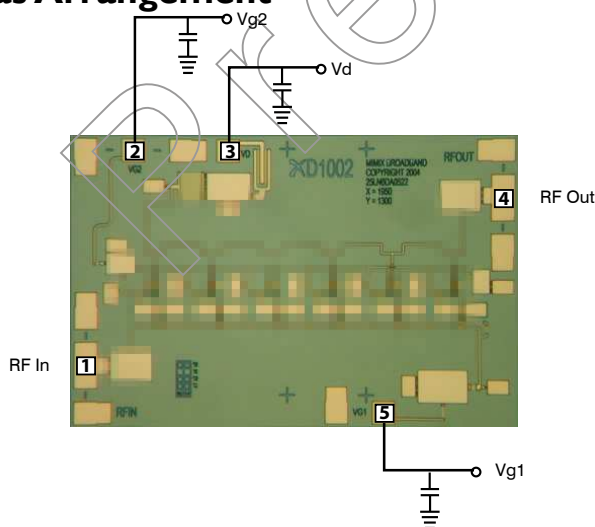

## Bypass Capacitors - See App Note [2]

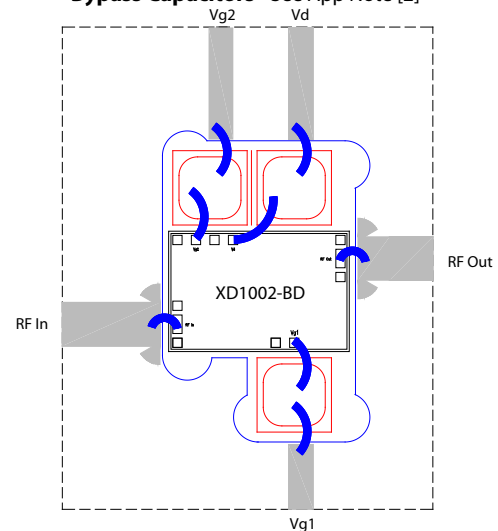

# 0.05-50.0 GHz GaAs MMIC Distributed Amplifier

January 2010 - Rev 18-Jan-10

**App Note [1] Biasing** - As shown in the bonding diagram, this device is operated with a single drain and gate voltage and it also includes a separate gain control voltage. Maximum gain bias is nominally  $V_d=8.5V$ ,  $V_{g1}=0.0V$ ,  $V_{g2}=1.0V$ , and  $I_d=120mA$ . Gain can be adjusted by changing  $V_{g1}$ . It is recommended to use active biasing to keep the currents constant as the RF power and temperature vary; this gives the most reproducible results. Depending on the supply voltage available and the power dissipation constraints, the bias circuit may be a single transistor or a low power operational amplifier, with a low value resistor in series with the drain supply used to sense the current. The gate of the pHEMT is controlled to maintain correct drain current and thus drain voltage. The typical gate voltage needed to do this is  $0.0V$ . Typically the gate is protected with Silicon diodes to limit the applied voltage. Also, make sure to sequence the applied voltage to ensure negative gate bias is available before applying the positive drain supply.

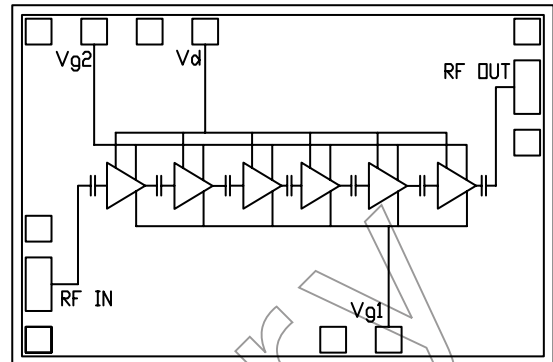

**App Note [2] Bias Arrangement** - Each DC pad ( $V_d$  and  $V_{g1,2}$ ) need to have DC bypass capacitance ( $\sim 100-200$  pF) as close to the device as possible. Additional DC bypass capacitance ( $\sim 0.01$   $\mu F$ ) is also recommended.

Preliminary

# 0.05-50.0 GHz GaAs MMIC Distributed Amplifier

January 2010 - Rev I8-Jan-10

## MTTF Graphs

These numbers were calculated based upon accelerated life test information received from the fabricating foundry and extensive thermal modeling/finite element analysis done at Mimix Broadband. The values shown here are only to be used as a guideline against the end application requirements and only represent reliability information under one bias condition. Ultimately bias conditions and resulting power dissipation along with the practical aspects, i.e. thermal material stack-up, attach method of device placement are the key parts in determining overall reliability for a specific application, see previous pages. If the data shown below does not meet your reliability requirements or if the bias conditions are not within your operating limits please contact technical sales for additional information.

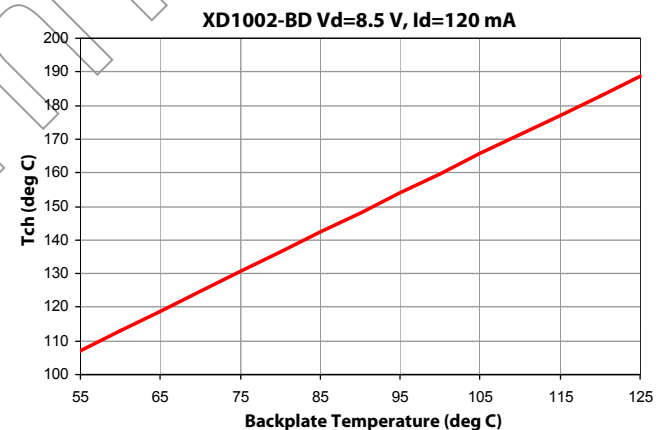
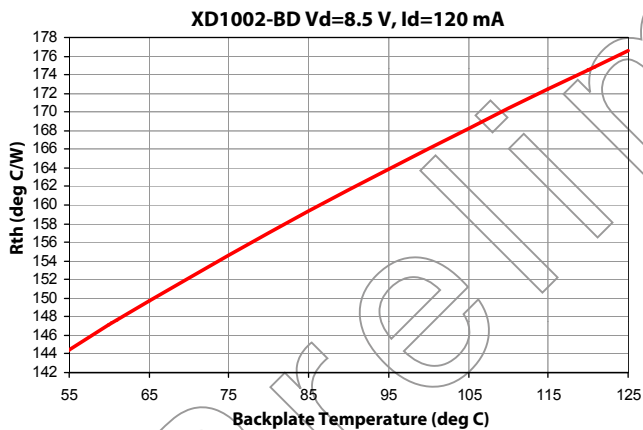
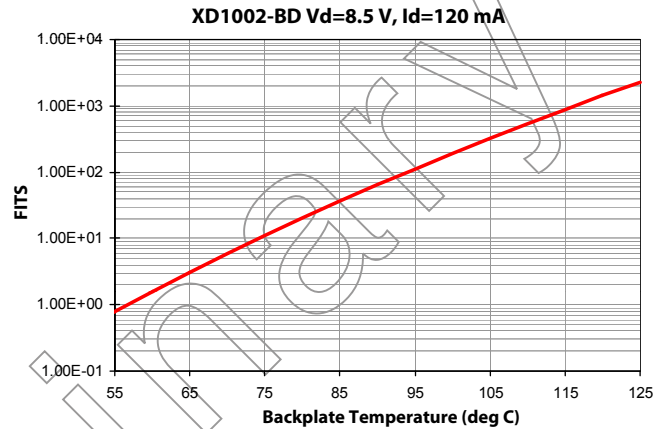
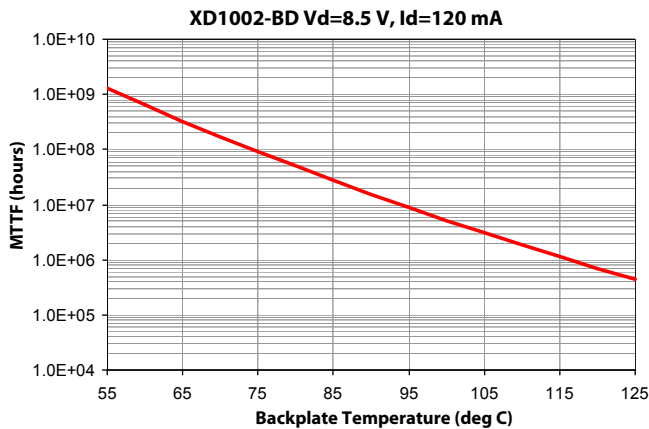

# 0.05-50.0 GHz GaAs MMIC Distributed Amplifier

January 2010 - Rev 18-Jan-10

## Handling and Assembly Information

**CAUTION!** - Mimix Broadband MMIC Products contain gallium arsenide (GaAs) which can be hazardous to the human body and the environment. For safety, observe the following procedures:

- Do not ingest.
- Do not alter the form of this product into a gas, powder, or liquid through burning, crushing, or chemical processing as these by-products are dangerous to the human body if inhaled, ingested, or swallowed.
- Observe government laws and company regulations when discarding this product. This product must be discarded in accordance with methods specified by applicable hazardous waste procedures.

**Life Support Policy** - Mimix Broadband's products are not authorized for use as critical components in life support devices or systems without the express written approval of the President and General Counsel of Mimix Broadband. As used herein: (1) Life support devices or systems are devices or systems which, (a) are intended for surgical implant into the body, or (b) support or sustain life, and whose failure to perform when properly used in accordance with instructions for use provided in the labeling, can be reasonably expected to result in a significant injury to the user. (2) A critical component is any component of a life support device or system whose failure to perform can be reasonably expected to cause the failure of the life support device or system, or to affect its safety or effectiveness.

**ESD** - Gallium Arsenide (GaAs) devices are susceptible to electrostatic and mechanical damage. Die are supplied in antistatic containers, which should be opened in cleanroom conditions at an appropriately grounded antistatic workstation. Devices need careful handling using correctly designed collets, vacuum pickups or, with care, sharp tweezers.

**Die Attachment** - GaAs Products from Mimix Broadband are 0.100 mm (0.004") thick and have vias through to the backside to enable grounding to the circuit. Microstrip substrates should be brought as close to the die as possible. The mounting surface should be clean and flat. If using conductive epoxy, recommended epoxies are Tanaka TS3332LD, Die Mat DM6030HK or DM6030HK-Pt cured in a nitrogen atmosphere per manufacturer's cure schedule. Apply epoxy sparingly to avoid getting any on to the top surface of the die. An epoxy fillet should be visible around the total die periphery. For additional information please see the Mimix "Epoxy Specifications for Bare Die" application note. If eutectic mounting is preferred, then a fluxless gold-tin (AuSn) preform, approximately 0.001<sup>2</sup> thick, placed between the die and the attachment surface should be used. A die bonder that utilizes a heated collet and provides scrubbing action to ensure total wetting to prevent void formation in a nitrogen atmosphere is recommended. The gold-tin eutectic (80% Au 20% Sn) has a melting point of approximately 280 °C (Note: Gold Germanium should be avoided). The work station temperature should be 310 °C +/- 10 °C. Exposure to these extreme temperatures should be kept to minimum. The collet should be heated, and the die pre-heated to avoid excessive thermal shock. Avoidance of air bridges and force impact are critical during placement.

**Wire Bonding** - Windows in the surface passivation above the bond pads are provided to allow wire bonding to the die's gold bond pads. The recommended wire bonding procedure uses 0.076 mm x 0.013 mm (0.003" x 0.0005") 99.99% pure gold ribbon with 0.5-2% elongation to minimize RF port bond inductance. Gold 0.025 mm (0.001") diameter wedge or ball bonds are acceptable for DC Bias connections. Aluminum wire should be avoided. Thermo-compression bonding is recommended though thermosonic bonding may be used providing the ultrasonic content of the bond is minimized. Bond force, time and ultrasonics are all critical parameters. Bonds should be made from the bond pads on the die to the package or substrate. All bonds should be as short as possible.

## Part Number for Ordering

XD1002-BD-000V  
XD1002-BD-EV1

## Description

RoHS compliant die packed in vacuum release gel packs  
XD1002-BD evaluation module



Caution: ESD Sensitive  
Appropriate precautions in handling, packaging  
and testing devices must be observed.

Proper ESD procedures should be followed when handling this device.

Mimix Broadband, Inc., 10795 Rockley Rd., Houston, Texas 77099  
Tel: 281.988.4600 Fax: 281.988.4615 mimixbroadband.com

Page 7 of 7