

Low Noise CATV Amplifier 50 - 1005 MHz

Rev. V1

Features

- Low Distortion
- Low Noise Figure
- Push Pull Design
- Single Positive Supply
- Lead-Free 4 mm 20-Lead PQFN Package
- 100% Matte Tin Plating over Copper
- Halogen-Free "Green" Mold Compound
- RoHS* Compliant and 260°C Reflow Compatible

Description

M/A-COM's MAAM-007724 is a GaAs PHEMT MMIC amplifier in a lead-free 4 mm 20-lead PQFN package. The MMIC design is configured as a pair of cascode PHEMT amplifiers for broadband performance. It is designed for integration in a 75-ohm push-pull, low distortion, amplifier circuit. The device is ideally suited for use in CATV, DBS, and HDTV applications where low noise figure and low distortion are required.

Ordering Information ¹

Part Number	Package
MAAM-007724-TR1000	1000 piece reel
MAAM-007724-TR3000	3000 piece reel
MAAM-007724-000SMB	Sample Test Board (Includes 5 Samples)

1. Reference Application Note M513 for reel size information.

Absolute Maximum Ratings ^{2,3}

Parameter	Absolute Maximum
Input Power	+20 dBm
Operating Voltage	+10 volts
Operating Temperature	-40°C to +85°C
Storage Temperature	-65°C to +150°C

- Exceeding any one or combination of these limits may cause permanent damage to this device.
- M/A-COM does not recommend sustained operation near these survivability limits.

Functional Schematic

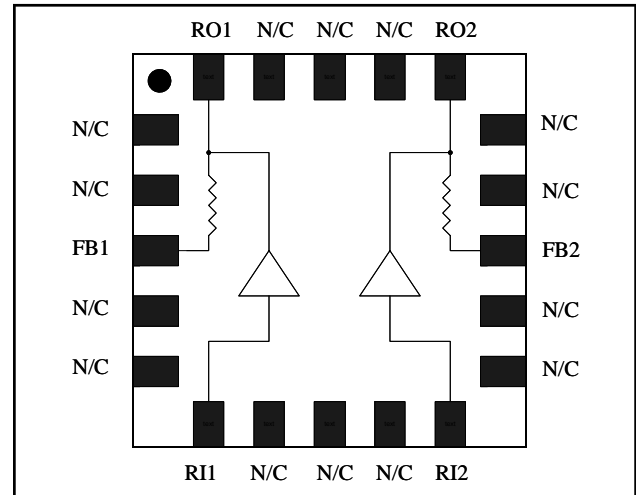

Pin Configuration ⁴

Pin No.	Pin Name	Description
1	N/C	No Connection
2	N/C	No Connection
3	FB1	Feedback 1
4	N/C	No Connection
5	N/C	No Connection
6	RI1	RF Input 1
7	N/C	No Connection
8	N/C	No Connection
9	N/C	No Connection
10	RI2	RF Input 2
11	N/C	No Connection
12	N/C	No Connection
13	FB2	Feedback 2
14	N/C	No Connection
15	N/C	No Connection
16	RO2	RF Output 2
17	N/C	No Connection
18	N/C	No Connection
19	N/C	No Connection
20	RO1	RF Output 1

4. The exposed pad centered on the package bottom must be connected to RF and DC ground.

* Restrictions on Hazardous Substances, European Union Directive 2002/95/EC.

ADVANCED: Data Sheets contain information regarding a product M/A-COM Technology Solutions is considering for development. Performance is based on target specifications, simulated results, and/or prototype measurements. Commitment to develop is not guaranteed.
PRELIMINARY: Data Sheets contain information regarding a product M/A-COM Technology Solutions has under development. Performance is based on engineering tests. Specifications are typical. Mechanical outline has been fixed. Engineering samples and/or test data may be available. Commitment to produce in volume is not guaranteed.

• **North America** Tel: 800.366.2266 / Fax: 978.366.2266
 • **Europe** Tel: 44.1908.574.200 / Fax: 44.1908.574.300
 • **Asia/Pacific** Tel: 81.44.844.8296 / Fax: 81.44.844.8298
 Visit www.macomtech.com for additional data sheets and product information.

M/A-COM Technology Solutions Inc. and its affiliates reserve the right to make changes to the product(s) or information contained herein without notice.

Low Noise CATV Amplifier 50 - 1005 MHz

Rev. V1

Electrical Specifications: $T_A = 25^\circ\text{C}$, Freq: 50 - 1005 MHz, $V_{DD} = +5$ Volts, $Z_0 = 75$ ohms
Test Circuit with M/A-COM Balun ETN1-1-13

Parameter	Test Conditions	Units	Min.	Typ.	Max.
Gain	—	dB	11.5	12.2	13.0
Gain Flatness	—	dB	—	0.4	1.0
Noise Figure	—	dB	—	3.3	4.0
Input VSWR	—	Ratio	—	1.3:1	—
Output VSWR	—	Ratio	—	1.5:1	—
Output IP3	Two tones at 397 & 403 MHz, +4 dBm output per tone	dBm	—	32	—
Composite Triple Beat, CTB	135 Channels, +13 dBmV/Channel at the input	dBc	—	-78	-70
Composite Second Order, CSO	135 Channels, +13 dBmV/Channel at the input	dBc	—	-78	-70
Cross modulation	135 Channels, +13 dBmV/Channel at the input	dBc	—	-73	-64
P1dB	400 MHz	dBm	—	24	—
I_{DD}	+5 Volts	mA	—	190	225

Test Circuit Schematic⁵

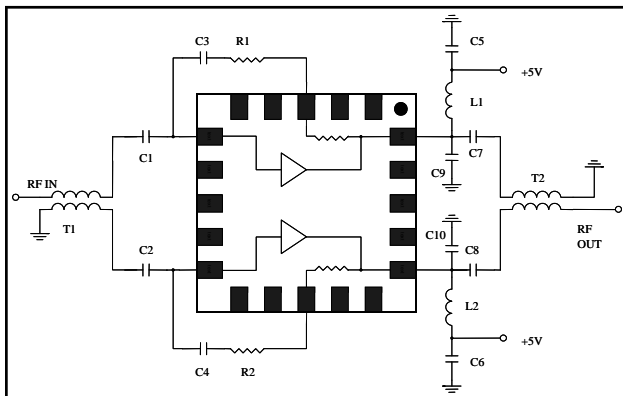

5. The 1:1 baluns, T1 & T2, are M/A-COM part number ETN1-1-13.

Recommended Test Circuit Layout⁶

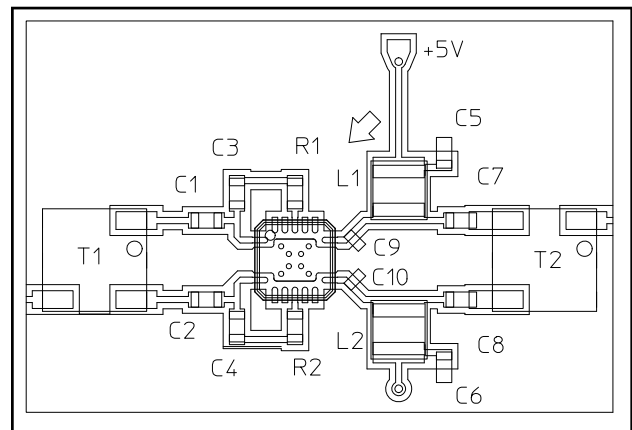

6. Reference M/A-COM Application Note S2083 for recommended PCB configuration. R1 and R2 are 0 ohms.

External Circuitry Parts List

Qty	Description
8	Capacitor, 0.01 μF , 0603, SMT, 10% (C1-C8)
2	Capacitor, 2 pF, 0402, SMT, $\pm 0.25\text{pF}$ (C9-C10)
2	Inductor, 390 nH, 1008, SMT, 10% (L1, L2)
2	Balun, 1:1, M/A-COM, ETN1-1-13, SMT (T1,T2)
2	Resistor, 0 ohms, 0603, SMT (R1, R2)

Handling Procedures

Please observe the following precautions to avoid damage:

Static Sensitivity

Gallium Arsenide Integrated Circuits are sensitive to electrostatic discharge (ESD) and can be damaged by static electricity. Proper ESD control techniques should be used when handling these devices.

Typical Performance Curves

Gain

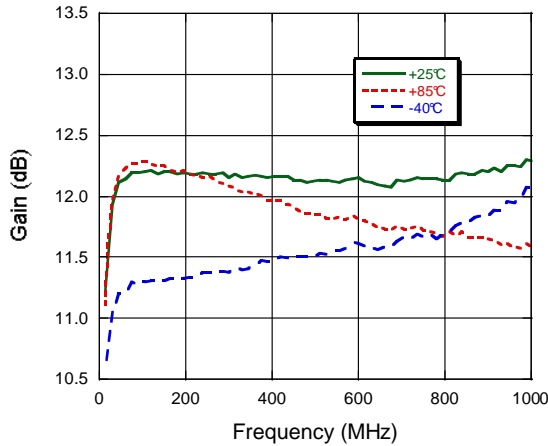

Gain vs. Frequency to 3 GHz

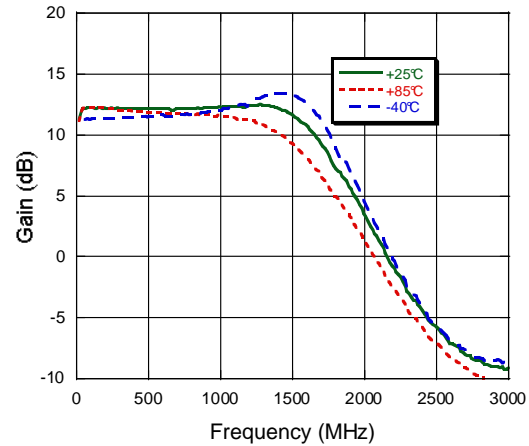

Input Return Loss

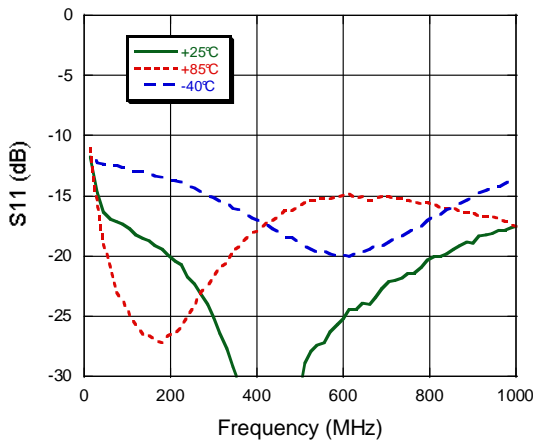

Output Return Loss

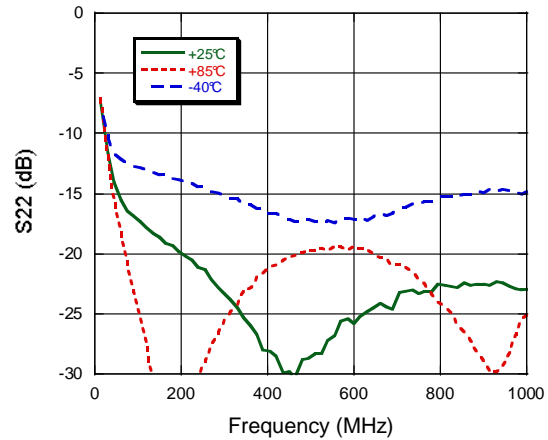

OIP

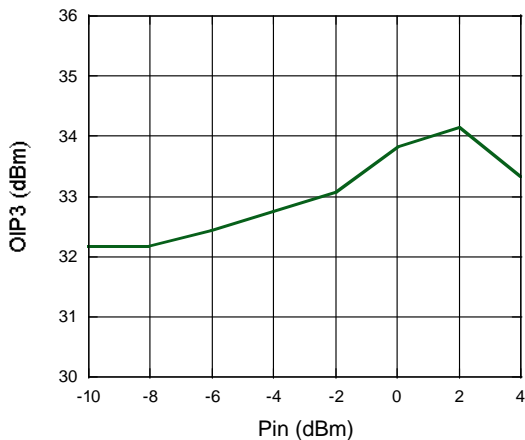

Noise Figure vs. Frequency, 25°C

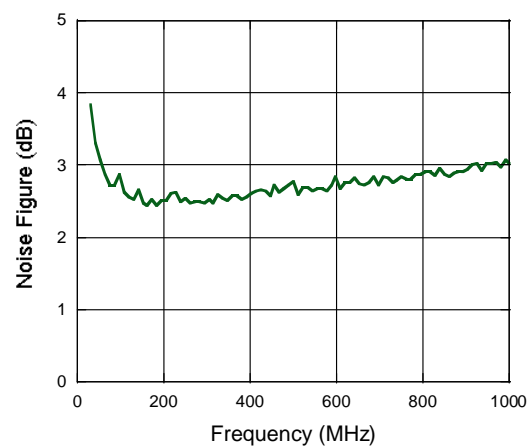

Low Noise CATV Amplifier 50 - 1005 MHz

Rev. V1

Typical Performance Curves (continued)

Gain vs. P_{OUT} at 400 MHz

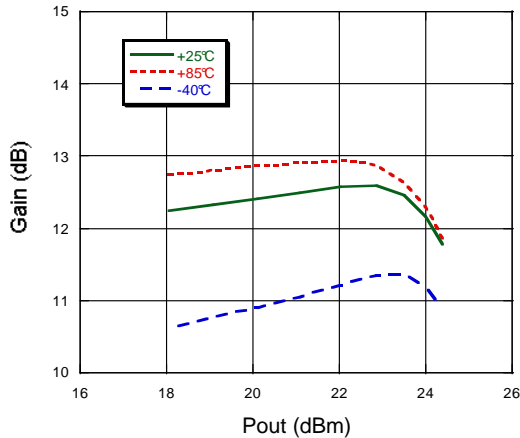

Lead-Free 4 mm 20-lead PQFN†

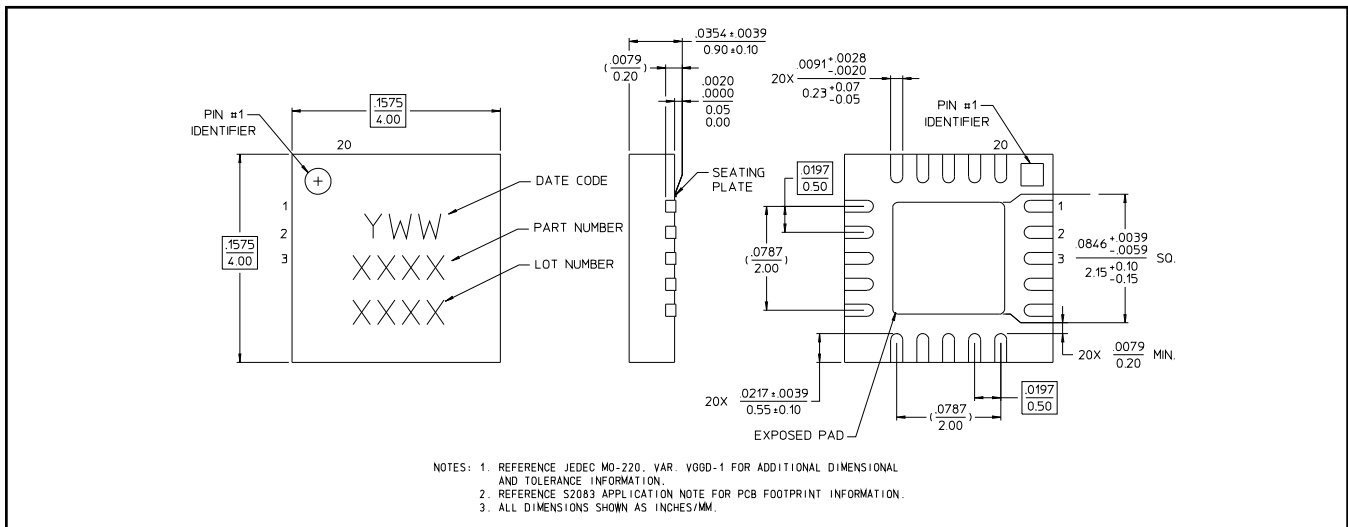

† Reference Application Note M538 for lead-free solder reflow recommendations.
Meets JEDEC moisture sensitivity level 1 requirements.