

Broadband CATV Single Ended 4-Way Active Splitter 50 - 1100 MHz

Rev. V1

Features

- 4-Way Splitter
- Single Ended Input and Outputs
- 2.5 dB Gain
- +15 dBmV /Channel Input
- 4.5 dB Noise Figure
- +3.3 Volt Bias
- Lead-Free 3 mm 12-Lead PQFN Package
- Halogen-Free "Green" Mold Compound
- RoHS* Compliant and 260°C Reflow Compatible

Description

The MAAM-009452 CATV 4-way active splitter is a GaAs MMIC which exhibits low noise figure and distortion in a lead-free 3mm 12-lead PQFN plastic package. The design features 75 Ω inputs and outputs.

This device is ideally suited for multi-tuner set top boxes, home gateways, and other broadband internet based applications.

The MAAM-009452 is fabricated using M/A-COM Technology Solutions pHEMT process to realize low noise and low distortion. The process features full passivation for robust performance and reliability.

Ordering Information ^{1,2}

Part Number	Package
MAAM-009452-TR1000	1000 piece reel
MAAM-009452-TR3000	3000 piece reel
MAAM-009452-001SMB	Sample Test Board

1. Reference Application Note M513 for reel size information.
2. All sample boards include 5 loose parts.

Functional Schematic

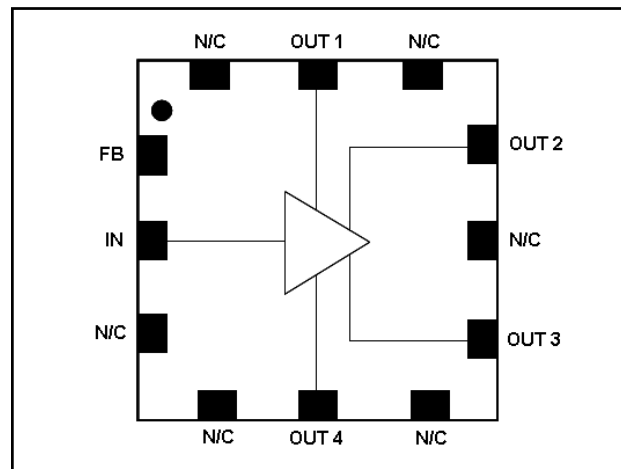

Pin Configuration

Pin No.	Pin Name	Description
1	FB	Feedback/Bias
2	IN	RF Input
3	N/C	No Connection
4	N/C	No Connection
5	OUT4	RF Output 4
6	N/C	No Connection
7	OUT3	RF Output 3
8	N/C	No Connection
9	OUT2	RF Output 2
10	N/C	No Connection
11	OUT1	RF Output 1
12	N/C	No Connection
13	Paddle ³	RF and DC Ground

3. The exposed pad centered on the package bottom must be connected to RF and DC ground.

* Restrictions on Hazardous Substances, European Union Directive 2002/95/EC.

Broadband CATV Single Ended 4-Way Active Splitter 50 - 1100 MHz

Rev. V1

Electrical Specifications: Freq. = 1000 MHz, T_A = 25°C, V_{DD} = +3.3 Volts, Z₀ = 75 Ω

Parameter	Test Conditions	Units	Min.	Typ.	Max.
Gain	IN to OUT1, OUT2, OUT3 & OUT4	dB	2.3	2.5	4.8
Gain Flatness	IN to OUT1, OUT2, OUT3 & OUT4	dB	-	0.5	-
Noise Figure	IN to OUT1, OUT2, OUT3 & OUT4	dB	-	4.5	-
Input Return Loss	IN	dB	-	15	-
Output Return Loss	OUT1, OUT2, OUT3, OUT4	dB	-	9	-
Composite Triple Beat, CTB	132 channels, +15 dBmV/channel at the input	dBc	-	-65	-
Composite Second Order, CSO	132 channels, +15 dBmV/channel at the input	dBc	-	-56	-
Reverse Isolation	OUT1, OUT2, OUT3 & OUT4 to IN	dB	-	28	-
Output to Output Isolation	Isolation between all RF outputs	dB	-	21	-
P1dB	IN to OUT1, OUT2, OUT3, OUT4	dB	-	5	-
OIP3	500 MHz, 2-tone, 6 MHz spacing, -15 dBm Pout	dBm	-	25	-
OIP2	500 MHz, 2-tone, 6 MHz spacing, -15 dBm Pout	dBm	-	40	-
I _{DD}	V _{DD} = +3.3 Volts	mA	-	96	120

Absolute Maximum Ratings^{4,5,6}

Parameter	Absolute Maximum
RF Input Power	12 dBm
Voltage	10.0 volts
Operating Temperature	-20°C to +85°C
Junction Temperature ⁷	+150°C
Storage Temperature	-65°C to +150°C

- Exceeding any one or combination of these limits may cause permanent damage to this device.
- M/A-COM Technology Solutions does not recommend sustained operation near these survivability limits.
- These operating conditions will ensure MTTF > 1 x 10⁶ hours.
- Junction Temperature (T_J) = T_C + Θ_{JC} * (V * I)
Typical thermal resistance (Θ_{JC}) = 101° C/W.
a) For T_C = 25°C,
T_J = 65°C @ 3.3 V, 120 mA
b) For T_C = 85°C,
T_J = 123 °C @ 3.3 V, 115 mA

Handling Procedures

Please observe the following precautions to avoid damage:

Static Sensitivity

Gallium Arsenide Integrated Circuits are sensitive to electrostatic discharge (ESD) and can be damaged by static electricity. Proper ESD control techniques should be used when handling these devices.

An external protection circuit using an inexpensive anti-parallel diode pair can be used to protect the IC.

Please reference application note AN3028 on <http://www.macomtech.com> for further detail.

Recommended PCB

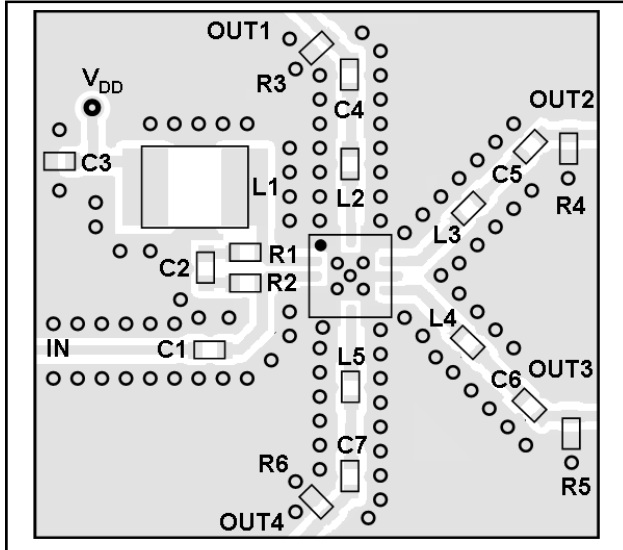

PCB Land Pattern

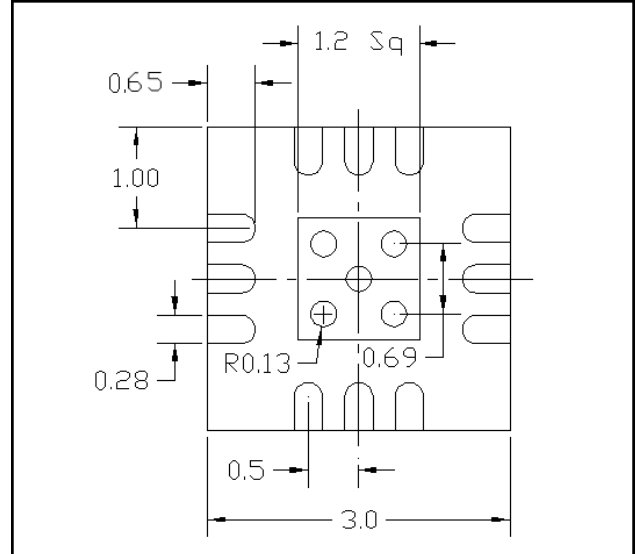

Schematic Including Off-Chip Components⁸

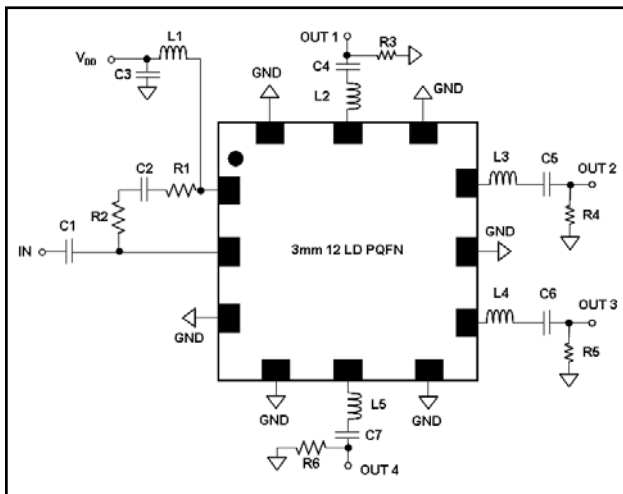

8. The exposed pad centered on the package bottom must be connected to ground for RF, DC and thermal considerations.

Off-Chip Component Values

Component	Value	Package
C1 - C7	0.01 μ F	0402
L1 ⁹	1 μ H	1210
L2 - L5	15 nH	0402
R1, R2	240 Ω	0402
R3 - R6	750 Ω	0402

9. L1 supplied from EPCOS, part number B82422A1102K100

Typical Performance Curves

Gain to 1100 MHz
Typical All Outputs

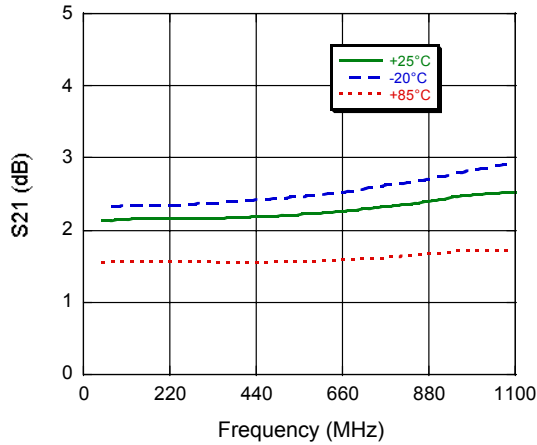

Gain to 3000 MHz
Typical All Outputs

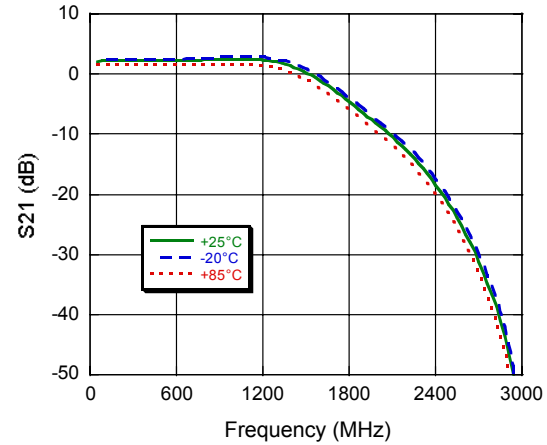

Input Return Loss

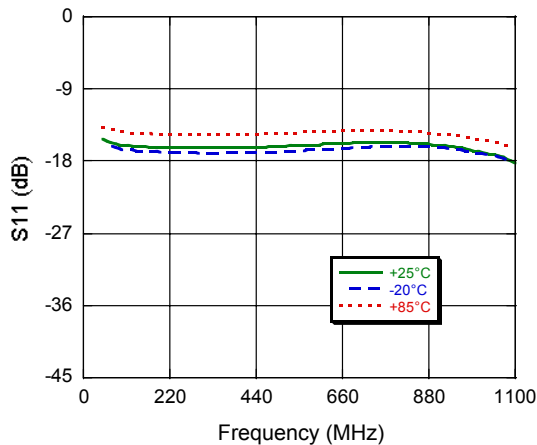

Output Return Loss
Typical All Outputs

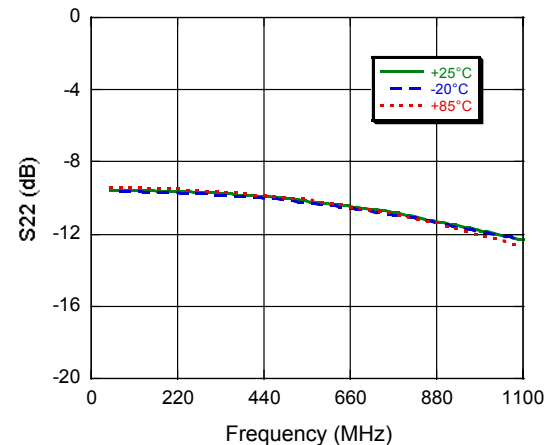

Typical Performance Curves

OUT-OUT Isolation to 1100 MHz
Typical Between All Outputs

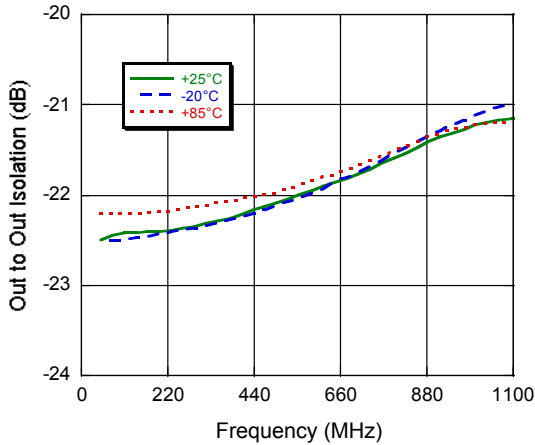

OUT-OUT Isolation to 3000 MHz
Typical Between All Outputs

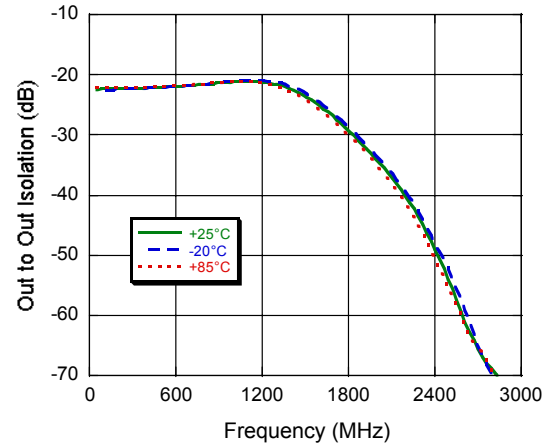

Noise Figure
Typical All Outputs

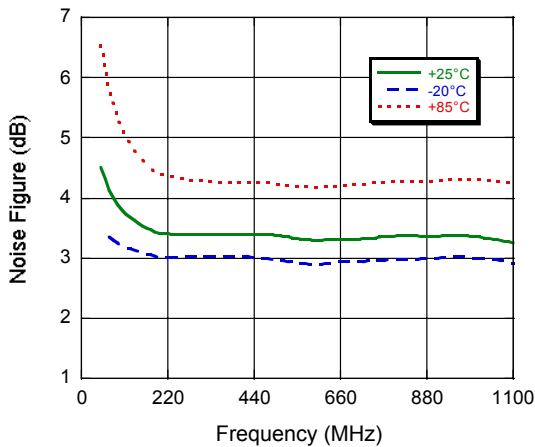

Reverse Isolation to 3000 MHz
Typical From All Outputs to Input

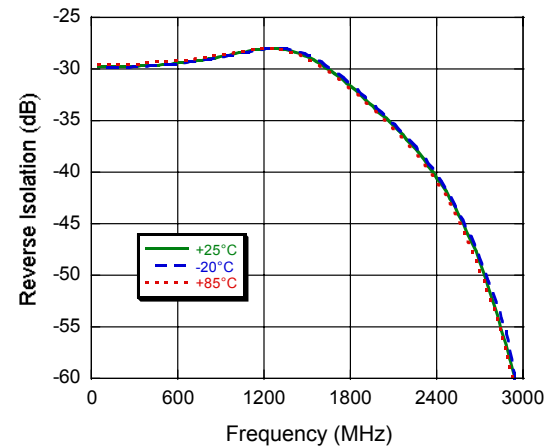

Broadband CATV Single Ended 4-Way Active Splitter 50 - 1100 MHz

Rev. V1

Lead-Free 3 mm 12-Lead PQFN[†]

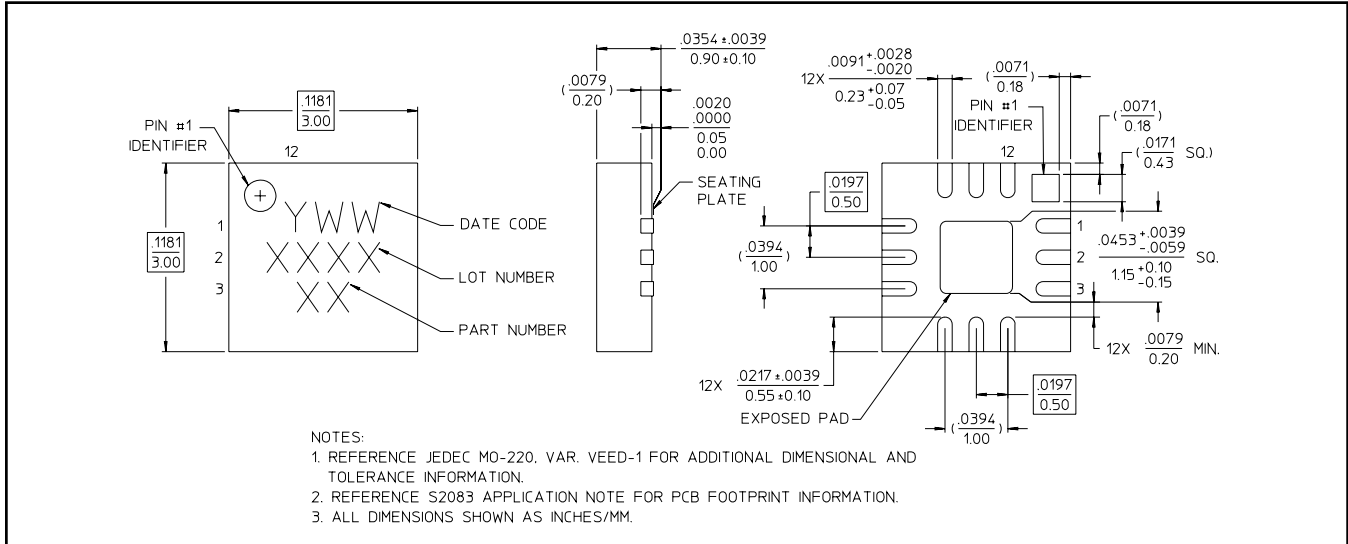

[†] Reference Application Note S2083 for lead-free solder reflow recommendations.
 Meets JEDEC moisture sensitivity level 1 requirements.
 Plating is 100% matte tin over copper.