

GaAs MMIC Power Amplifier 2.0 - 6.5 GHz

Rev. V7

Features

- Saturated Power: 30.5 dBm Typical
- Gain: 19 dB Typical
- Power Added Efficiency: 30%
- On-Chip Bias Network
- DC Decoupled RF Input and Output
- RoHS* Compliant

Description

The MAAM26100 is a GaAs MMIC two stage high efficiency power amplifier. The MAAM26100 is a fully monolithic design which eliminates the need for external circuitry in 50-ohm systems.

The MAAM26100 is ideally suited for driver amplifiers and transmitter outputs in UMTS applications, test equipment, electronic warfare jammers, missile subsystems and phased array radars.

The MAAM26100 is fabricated using a mature 0.5-micron gate length GaAs process. The process features full passivation for increased performance reliability.

Ordering Information

Part Number	Package
MAAM26100	Die

Die

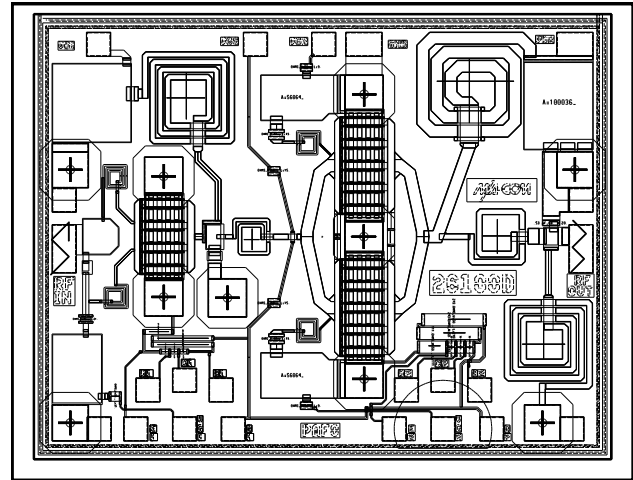

Absolute Maximum Ratings ^{1,2}

Parameter	Absolute Maximum
V_{DD}	+9 V
V_{G1}, V_{G2}	-2.5 V to -0.8 V
V_{GG}^3	-6 V to -3 V
RF Input Power	+17 dBm
Channel Temperature	150°C
Storage Temperature	-65°C to +150°C

1. Exceeding any one or combination of these limits may cause permanent damage to this device and will void product warranty.
2. M/A-COM does not recommend sustained operation near these survivability limits.
3. V_{GG} rating applies when using the optional on-chip resistor network.

GaAs MMIC Power Amplifier 2.0 - 6.5 GHz

Rev. V7

Electrical Specifications: $T_A = 25^\circ\text{C}$, $Z_0 = 50 \Omega$, $V_{DD} = +8 \text{ V}$, $V_{GG} = -1.3 \text{ V}$ nominal

Parameter	Test Conditions	Units	Min.	Typ.	Max.
Small Signal Gain	2 - 6 GHz	dB	15	19	—
Input VSWR	2 - 6 GHz	Ratio	—	2.0:1	—
Output VSWR	2 - 6 GHz	Ratio	—	2.2:1	—
Saturated Output Power	Input Power +14 dBm, 2 - 6 GHz	dBm	29	30.5	—
Output Power at 1 dB Gain Compression	2 - 6 GHz	dBm	—	28	—
Power Added Efficiency	—	%	—	30	—
Third Order Intercept	2 - 6 GHz	dBm	—	39	—
Reverse Isolation	2 - 6 GHz	dB	—	30	—
Bias Current	No RF	mA	—	390	—
	$P_{IN} = +14 \text{ dBm}$	mA	—	475	650
Thermal Resistance ⁴	—	$^\circ\text{C/W}$	—	14	—

4. Attachment method not included.

Schematic

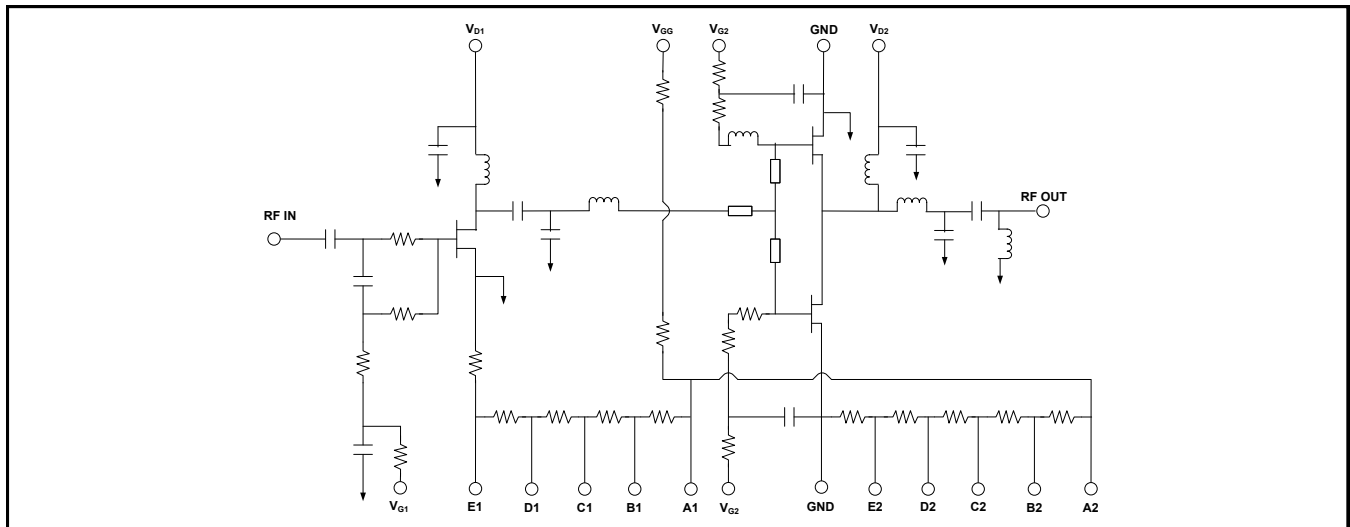

Typical Performance Curves

Input Return Loss

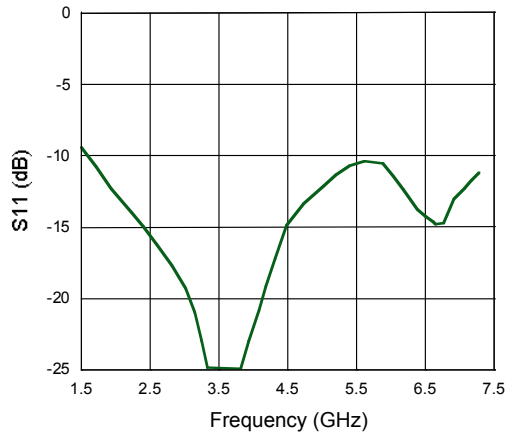

Gain

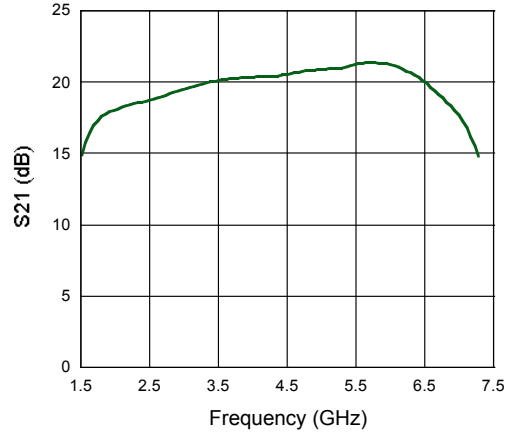

Power Added Efficiency @ $P_{IN} = +14$ dBm

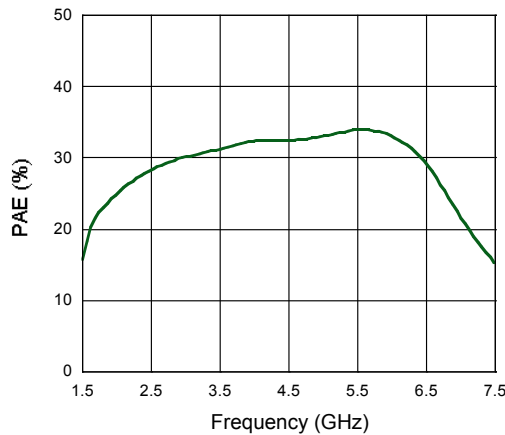

Output Power @ $P_{IN} = +14$ dBm

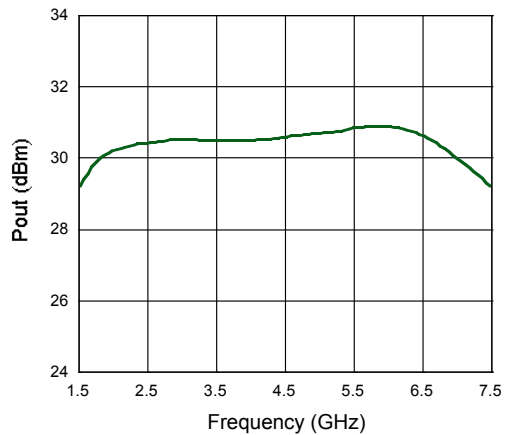

Handling Procedures

Permanent damage to the MAAM26100 may occur if the following precautions are not adhered to:

- A. Cleanliness - The MAAM26100 should be handled in a clean environment. DO NOT attempt to clean assembly after the MAAM26100 is installed.
- B. Static Sensitivity - All die handling equipment and personnel should comply with DOD-STD-1686 Class I.
- C. Transients - Avoid instrument and power supply transients while bias is connected to the MAAM26100. Use shielded signal and bias cables to minimize inductive pick-up.
- D. General Handling - DO NOT touch the surface of the die. It is recommended that the MAAM26100 die be handled along the long side with a sharp pair of tweezers.

Mounting

The MAAM26100 is back-metallized with Pd/Ni/Au (100/1,000/30,000Å) metallization. It is recommended that the die be mounted with Au/Sn eutectic preforms. The attachment surface should be clean and flat.

- A. An 80/20 preform is recommended with a work surface temperature of approximately 255°C and a tool temperature of 265°C. When hot 90/5 nitrogen/hydrogen gas is applied, solder temperature should be approximately 290°C.
- B. DO NOT expose the MAAM26100 to a temperature greater than 320°C for more than 20 seconds. No more than 3 seconds of scrubbing should be required for attachment.

Bonding

- A. Ball or wedge bond with 1.0 mil diameter gold wire of 3.0 mil x 0.5 mil ribbon. Thermosonic bonding with a nominal stage temperature of 150°C and a ball bonding force of 40 to 50 grams or wedge bonding force of 18 to 22 grams is recommended. Ultrasonic energy and time should be adjusted to the minimum levels necessary to achieve reliable bonds.
- B. Bonds should be started on the die and terminated on the package.
- C. Bonding pads are 4.0 x 4.0 mils minimum.

Typical Bias Configuration ^{5,6}

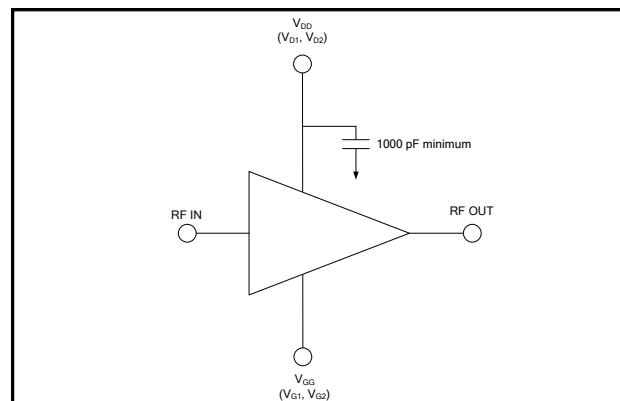

5. Nominal bias is obtained by first connecting -1.3 volts to pads V_{G1} and V_{G2} followed by connecting +8 volts to pads V_{D1} and V_{D2} (note sequence).
6. The recommended V_{DD} range is +6 to +9 volts.

Bonding Table ⁷

Bin #	Bond Pads
1	E1 to V_{G1} , E2 to V_{G2}
2	D1 to V_{G1} , D2 to V_{G2}
3	C1 to V_{G1} , C2 to V_{G2}
4	B1 to V_{G1} , B2 to V_{G2}

7. Optional on-chip resistor networks are used by connecting a nominal -5 volts to the pad V_{GG} then connecting pads per the bonding table.

Each gel pack is labeled with a CD # which corresponds to a Bin # in the bonding table. For example, CD1 on the gel pack corresponds to Bin 1, which means that pad E1 must be connected to pad V_{G1} and pad E2 must be connected to pad V_{G2} .

Outline Drawing

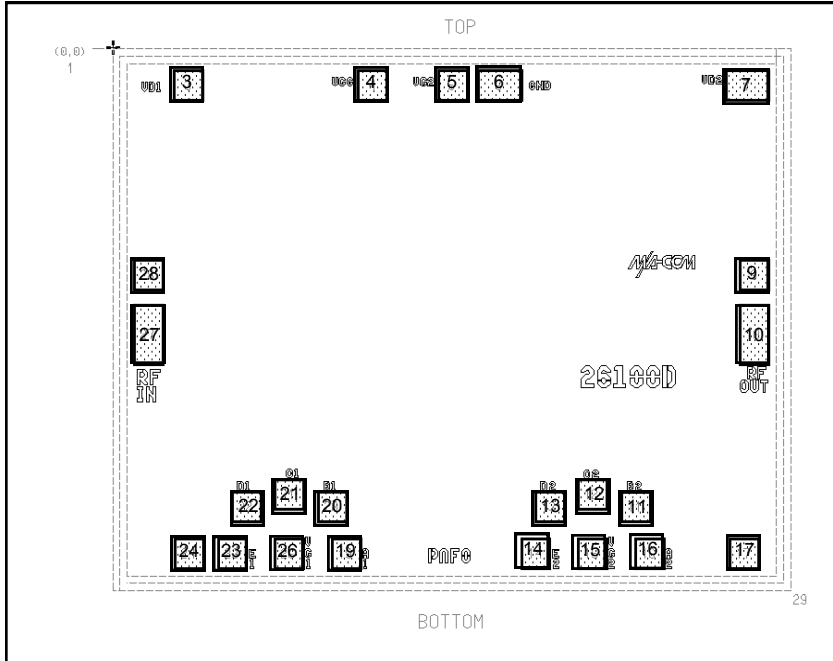

Pad Configuration ⁸

Die Size: 2.342 x 1.802 x 0.102 mm (nominal)

Pad No.	X (mm) nominal	Y (mm) nominal	Pad Size (mm)	Description	Pad No.	X (mm) nominal	Y (mm) nominal	Pad Size (mm)	Description
3	0	0	.10 x .10	VD1	16	1.613	1.580	.10 x .10	A2
4	0.6435	0	.10 x .10	VGG	17	1.942	1.580	.10 x .10	GND
5	0.9235	0	.10 x .10	VG2	19	0.5525	1.580	.10 x .10	A1
6	1.0885	0	.15 x .10	GND	20	0.5025	1.420	.10 x .10	B1
7	1.954	0	.15 x .10	VD2	21	0.3525	1.380	.10 x .10	C1
9	1.979	0.640	.10 x .10	GND	22	0.2025	1.420	.10 x .10	D1
10	1.979	0.840	.10 x .20	RF _{OUT}	23	0.1525	1.580	.10 x .10	E1
11	1.564	1.420	.10 x .10	B2	24	0.0025	1.580	.10 x .10	GND
12	1.413	1.380	.10 x .10	C2	26	0.3525	1.580	.10 x .10	VG1
13	1.263	1.420	.10 x .10	D2	27	-0.141	0.840	.10 x .20	RF _{IN}
14	1.213	1.580	.15 x .10	E2	28	-0.141	0.640	.10 x .10	GND
15	1.413	1.580	.15 x .10	VG2					

8. All X,Y locations are at pad center.