

Features

- ◆ Broad Bandwidth Specified 18 to 40GHz
- ◆ Usable 10GHz to 50 GHz
- ◆ Extremely Low Insertion Loss
- ◆ High RF-DC Isolation
- ◆ Rugged, Fully Monolithic Glass Encapsulation

Description

The MA4BN1840-1 is a fully monolithic broadband bias network utilizing M/A-COM's HMIC™ (Heterolithic Microwave Integrated Circuit) process, US Patent 5,268,310. This process allows the formation of silicon vias by imbedding them in low loss, low dispersion glass along with high Q spiral inductors and MIM capacitors. The close proximity between elements and the combination of silicon and glass gives this HMIC device low loss and high performance with exceptional repeatability through millimeter frequencies.

Large bond pads facilitate the use of low inductance ribbon bonds, while the gold backside metallization provides the RF and DC ground. This allows for manual or automatic die attach via electrically conductive silver epoxy or RoHS compliant solders.

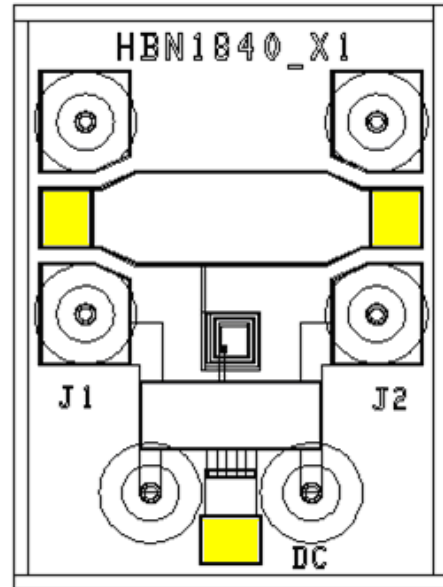

Yellow areas denote bond pads

Applications

The MA4BN1840-1 bias network is suitable for the D.C. biasing of PIN diode control circuits. It functions as an RF-DC de-coupling network as well as the D.C. return. The device can also be used as a bi-directional re-active coupler for Schottky detector circuits. D.C. currents up to 150 mA and D.C. voltages up to 50 V may be used.

**Maximum Operating Conditions at +25°C
(Unless otherwise noted)**

Parameter	Value
Operating Temperature	-65°C to +125°C
Storage Temperature	-65°C to +150°C
Die Attach Temperature	320°C for 20 sec
RF C.W. Incident Power	10 Watts
D.C. Bias Current	+/- 150 mA
D.C. Bias Voltage	+/- 50 V

Schematic

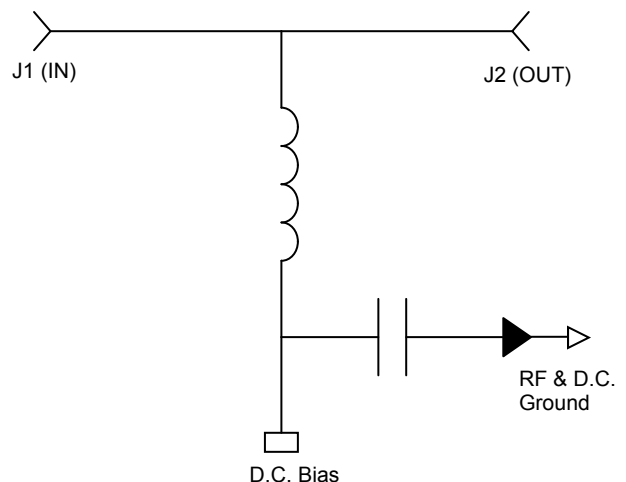

ADVANCED: Data Sheets contain information regarding a product MA-COM Technical Solutions is considering for development. Performance is based on target specifications, simulated results, and/or prototype measurements. Commitment to develop is not guaranteed.
PRELIMINARY: Data Sheets contain information regarding a product MA-COM Technical Solutions has under development. Performance is based on engineering tests. Specifications are typical. Mechanical outline has been fixed. Engineering samples and/or test data may be available. Commitment to produce in volume is not guaranteed.

- **North America** Tel: 800.366.2266 / Fax: 978.366.2266
- **Europe** Tel: 44.1908.574.200 / Fax: 44.1908.574.300
- **Asia/Pacific** Tel: 81.44.844.8296 / Fax: 81.44.844.8298

Visit www.macom.com for additional data sheets and product information.

MA-COM Technical Solutions and its affiliates reserve the right to make changes to the product(s) or information contained herein without notice.

Electrical Specifications @ T_{AMB} = +25°C on Wafer Measurements

Parameter	Frequency	Minimum Value	Average Value	Maximum Value	Units
Insertion Loss	18-40 GHz	-	0.15	0.2	dB
RF - DC Isolation	18-40 GHz	30	35	-	dB
Input Return Loss	18-40 GHz	15	17	-	dB
Output Return Loss	18-40 GHz	15	17	-	dB

Typical RF Performance at T_A = +25°C

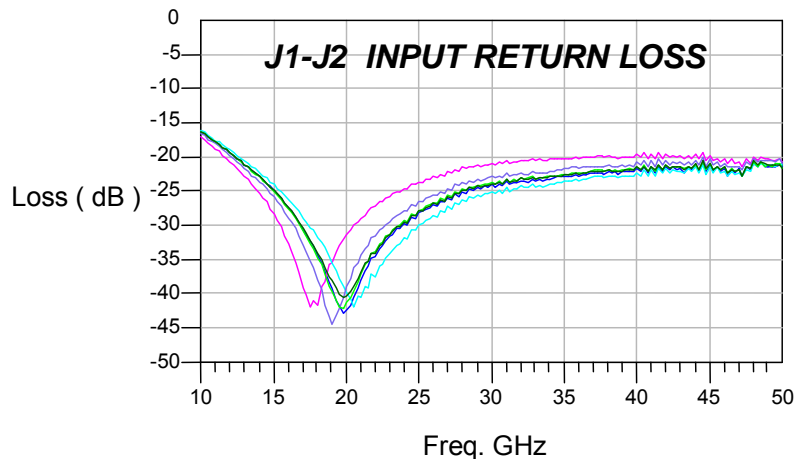
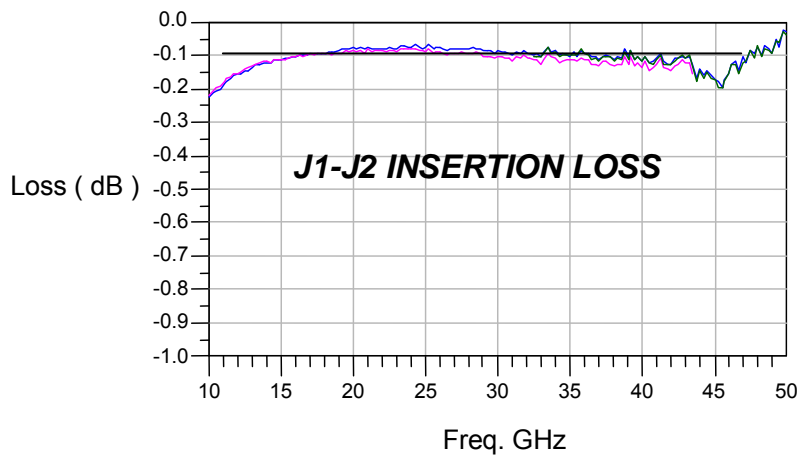

ADVANCED: Data Sheets contain information regarding a product MA-COM Technical Solutions is considering for development. Performance is based on target specifications, simulated results, and/or prototype measurements. Commitment to develop is not guaranteed.
PRELIMINARY: Data Sheets contain information regarding a product MA-COM Technical Solutions has under development. Performance is based on engineering tests. Specifications are typical. Mechanical outline has been fixed. Engineering samples and/or test data may be available. Commitment to produce in volume is not guaranteed.

- **North America** Tel: 800.366.2266 / Fax: 978.366.2266
- **Europe** Tel: 44.1908.574.200 / Fax: 44.1908.574.300
- **Asia/Pacific** Tel: 81.44.844.8296 / Fax: 81.44.844.8298

Visit www.macom.com for additional data sheets and product information.

MA-COM Technical Solutions and its affiliates reserve the right to make changes to the product(s) or information contained herein without notice.

Typical RF Performance at T_A = +25°C

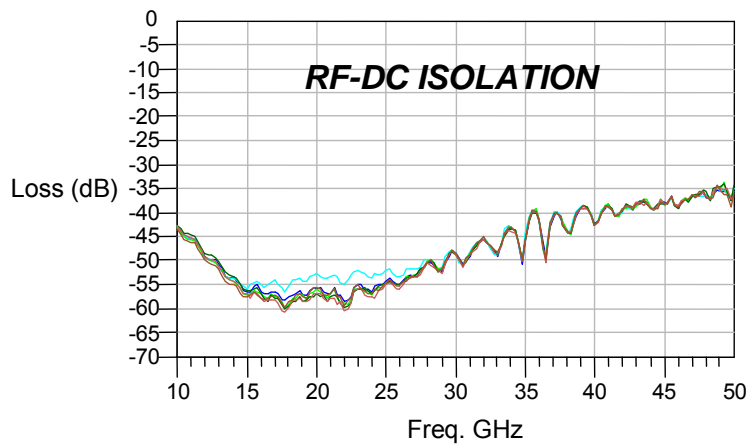
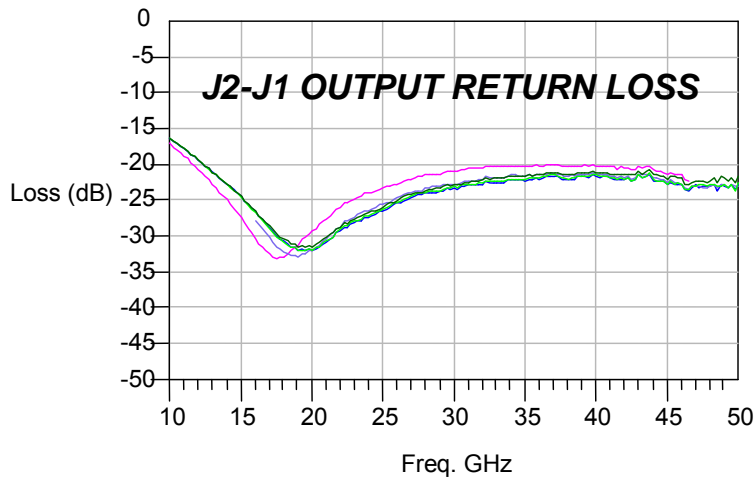

ADVANCED: Data Sheets contain information regarding a product MA-COM Technical Solutions is considering for development. Performance is based on target specifications, simulated results, and/or prototype measurements. Commitment to develop is not guaranteed.
PRELIMINARY: Data Sheets contain information regarding a product MA-COM Technical Solutions has under development. Performance is based on engineering tests. Specifications are typical. Mechanical outline has been fixed. Engineering samples and/or test data may be available. Commitment to produce in volume is not guaranteed.

- **North America** Tel: 800.366.2266 / Fax: 978.366.2266
- **Europe** Tel: 44.1908.574.200 / Fax: 44.1908.574.300
- **Asia/Pacific** Tel: 81.44.844.8296 / Fax: 81.44.844.8298

Visit www.macom.com for additional data sheets and product information.

MA-COM Technical Solutions and its affiliates reserve the right to make changes to the product(s) or information contained herein without notice.

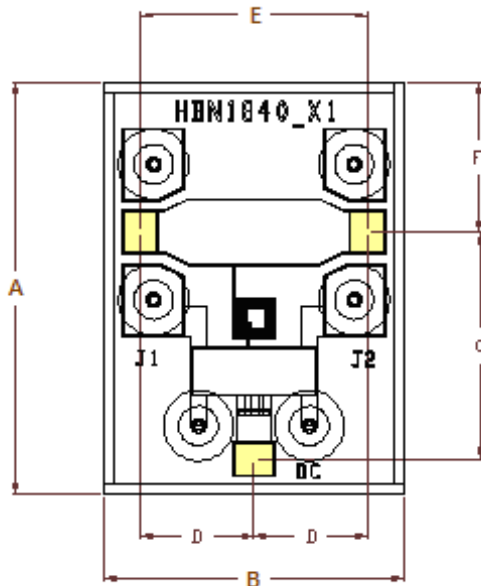

DIM	MILLIMETERS		MILS	
	MIN	MAX	MIN	MAX
A	1.44	1.45	56.69	57.09
B	1.04	1.05	40.94	41.34
C	0.80	0.82	31.50	32.28
D	0.40	0.42	15.75	16.54
E	0.81	0.83	31.89	32.68
F	0.52	0.55	20.47	21.65
RF Bond Pads	0.150 X 0.125 REF.		5.90 X 4.92	
DC Bond Pad	0.150 X 0.125 REF.		5.90 X 4.92	
Thickness	0.005	REF.	0.125	REF.

Assembly Considerations

Cleanliness

These chips should be handled in a clean environment.

Electro-Static Sensitivity

The MA4BN1840-1 bias network is ESD, Class 1B sensitive. The proper ESD handling procedures should be used.

Wire Bonding

Thermosonic wedge wire bonding using 0.003” x 0.00025” ribbon or ball bonding with 0.001” diameter gold wire is recommended. A stage temperature of 150°C and a force of 18 to 22 grams should be used. Ultrasonic energy should be adjusted to the minimum required. RF bonds should be as short as possible for best performance.

Mounting

These chips have Ti-Pt-Au topside and backside metal. They can be die mounted with either a gold-tin eutectic solder preform, RoHS compliant solders or electrically conductive silver epoxy. Mounting surface must be clean of organic contaminants and flat for best adhesion results.

Eutectic Die Attachment

An 80/20 gold-tin eutectic solder preform is recommended with a work surface temperature of 255°C and a tool tip temperature of 265°C. When hot gas is applied, the tool tip temperature should be 290°C. The chip should not be exposed to temperatures greater than 320°C for more than 20 seconds. No more than three seconds should be required for attachment.

Electrically Conductive Epoxy Die Attachment

Assembly should be preheated to 125-150°C. A minimum amount of epoxy should be used, approximately 1 to 2 mils thickness for best electrical and thermal conductivity. A thin epoxy fillet should be visible around the perimeter of the chip after placement. Cure epoxy per manufacturer’s time-temperature schedule. Typically 150°C for 1 hour.

RoHS Soldering

See application note [M538 page 7](#) on the [M/A-COM website](#) for the recommended heating profile.

ADVANCED: Data Sheets contain information regarding a product MA-COM Technical Solutions is considering for development. Performance is based on target specifications, simulated results, and/or prototype measurements. Commitment to develop is not guaranteed.
PRELIMINARY: Data Sheets contain information regarding a product MA-COM Technical Solutions has under development. Performance is based on engineering tests. Specifications are typical. Mechanical outline has been fixed. Engineering samples and/or test data may be available. Commitment to produce in volume is not guaranteed.

- **North America** Tel: 800.366.2266 / Fax: 978.366.2266
- **Europe** Tel: 44.1908.574.200 / Fax: 44.1908.574.300
- **Asia/Pacific** Tel: 81.44.844.8296 / Fax: 81.44.844.8298

Visit www.macom.com for additional data sheets and product information.

MA-COM Technical Solutions and its affiliates reserve the right to make changes to the product(s) or information contained herein without notice.

Operation of the MA4BN1840-1

Broadband operation of the MA4BN1840-1 bias network is accomplished by applying D.C. bias to the DC port on the die. The outputs, J1 and/or J2 provide the D.C. bias to the corresponding, connected, microwave device. An external blocking capacitor is required if the current is to be directed to only one RF output port such as in a bias T configuration. This device can also be used as a ground return when the DC Bias Port is attached to the RF and D.C. ground. The small D.C. resistance ($< 1 \Omega$) of the D.C. Bias Port allows up to $\pm 150 \text{ mA}$ @ $\pm 50 \text{ V}$ to be delivered while still maintaining $> 35 \text{ dB}$ RF to D.C. isolation.

MA4BN1840-1 Schematic

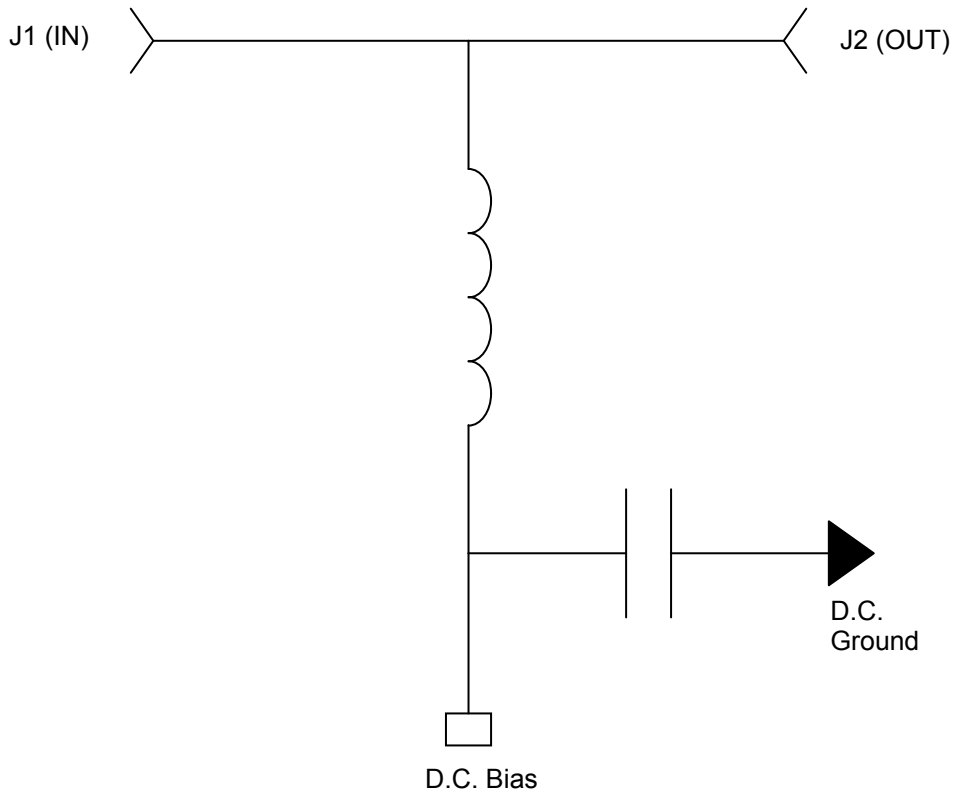

ADVANCED: Data Sheets contain information regarding a product MA-COM Technical Solutions is considering for development. Performance is based on target specifications, simulated results, and/or prototype measurements. Commitment to develop is not guaranteed.
PRELIMINARY: Data Sheets contain information regarding a product MA-COM Technical Solutions has under development. Performance is based on engineering tests. Specifications are typical. Mechanical outline has been fixed. Engineering samples and/or test data may be available. Commitment to produce in volume is not guaranteed.

- **North America** Tel: 800.366.2266 / Fax: 978.366.2266
- **Europe** Tel: 44.1908.574.200 / Fax: 44.1908.574.300
- **Asia/Pacific** Tel: 81.44.844.8296 / Fax: 81.44.844.8298

Visit www.macom.com for additional data sheets and product information.

MA-COM Technical Solutions and its affiliates reserve the right to make changes to the product(s) or information contained herein without notice.

Biasing Applications using the MA4BN1840-1

Bias Circuit for Shunt Diode Switch

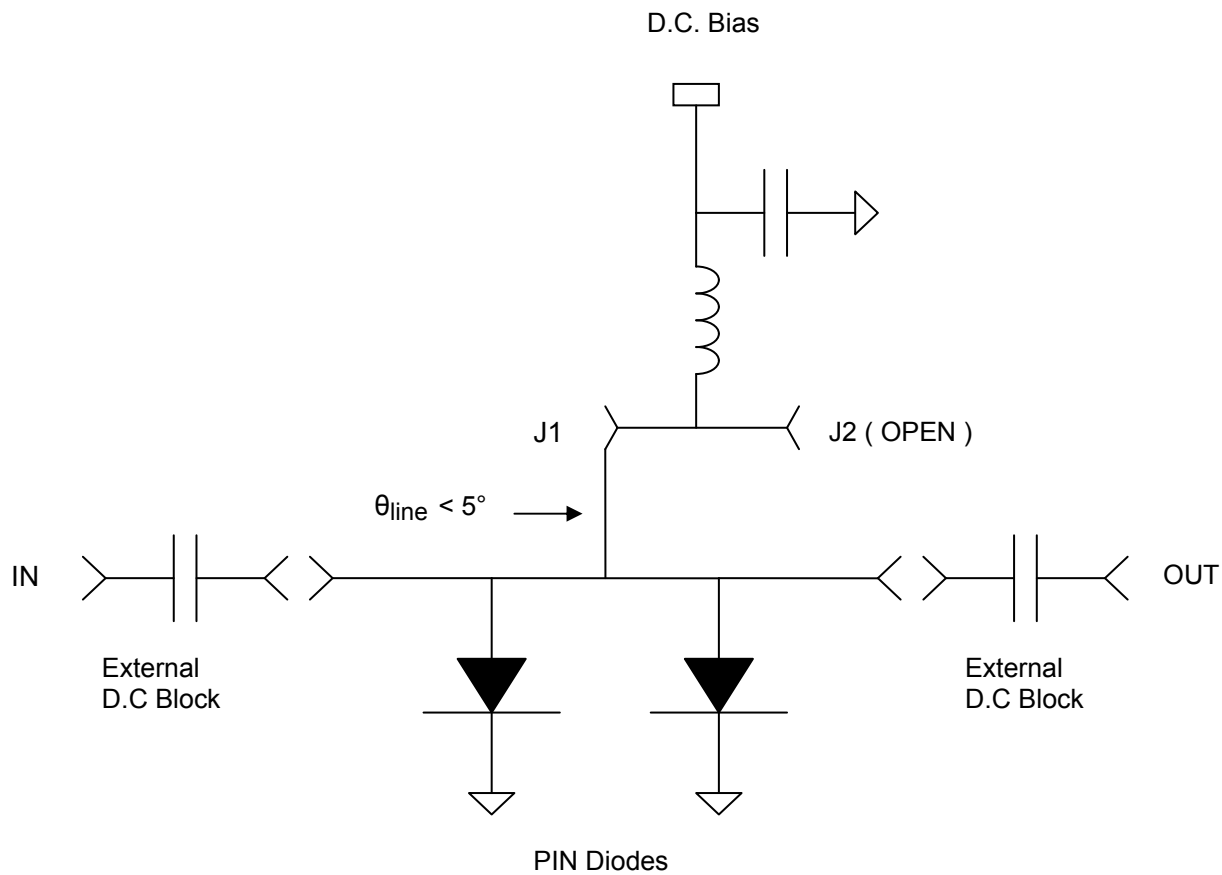

ADVANCED: Data Sheets contain information regarding a product MA-COM Technical Solutions is considering for development. Performance is based on target specifications, simulated results, and/or prototype measurements. Commitment to develop is not guaranteed.
PRELIMINARY: Data Sheets contain information regarding a product MA-COM Technical Solutions has under development. Performance is based on engineering tests. Specifications are typical. Mechanical outline has been fixed. Engineering samples and/or test data may be available. Commitment to produce in volume is not guaranteed.

- **North America** Tel: 800.366.2266 / Fax: 978.366.2266
- **Europe** Tel: 44.1908.574.200 / Fax: 44.1908.574.300
- **Asia/Pacific** Tel: 81.44.844.8296 / Fax: 81.44.844.8298

Visit www.macom.com for additional data sheets and product information.

MA-COM Technical Solutions and its affiliates reserve the right to make changes to the product(s) or information contained herein without notice.

Bias Circuit for Series Switch

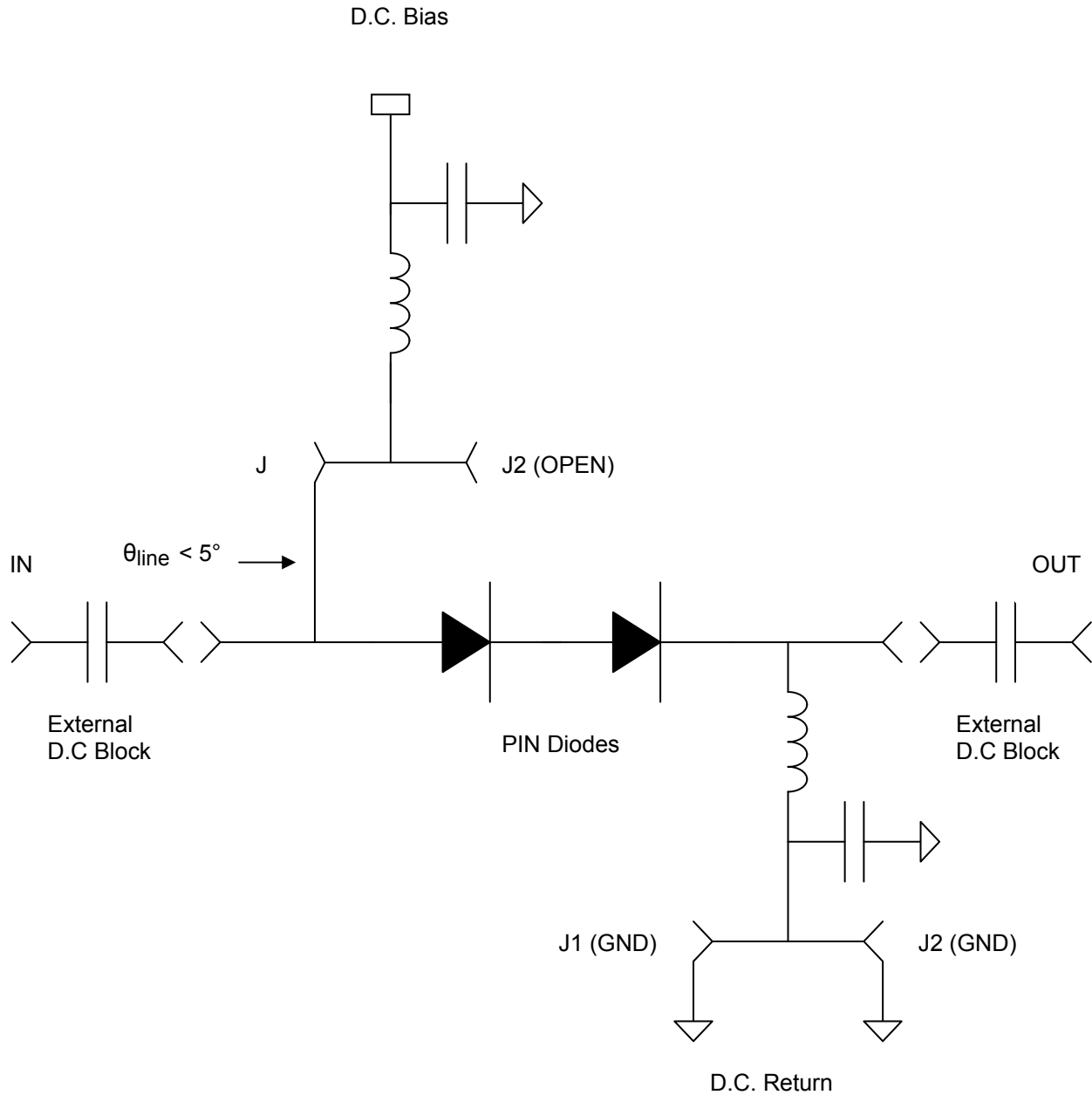

ADVANCED: Data Sheets contain information regarding a product MA-COM Technical Solutions is considering for development. Performance is based on target specifications, simulated results, and/or prototype measurements. Commitment to develop is not guaranteed.

PRELIMINARY: Data Sheets contain information regarding a product MA-COM Technical Solutions has under development. Performance is based on engineering tests. Specifications are typical. Mechanical outline has been fixed. Engineering samples and/or test data may be available. Commitment to produce in volume is not guaranteed.

- **North America** Tel: 800.366.2266 / Fax: 978.366.2266
- **Europe** Tel: 44.1908.574.200 / Fax: 44.1908.574.300
- **Asia/Pacific** Tel: 81.44.844.8296 / Fax: 81.44.844.8298

Visit www.macom.com for additional data sheets and product information.

MA-COM Technical Solutions and its affiliates reserve the right to make changes to the product(s) or information contained herein without notice.

Bias Circuit for Series - Shunt Diode Switch

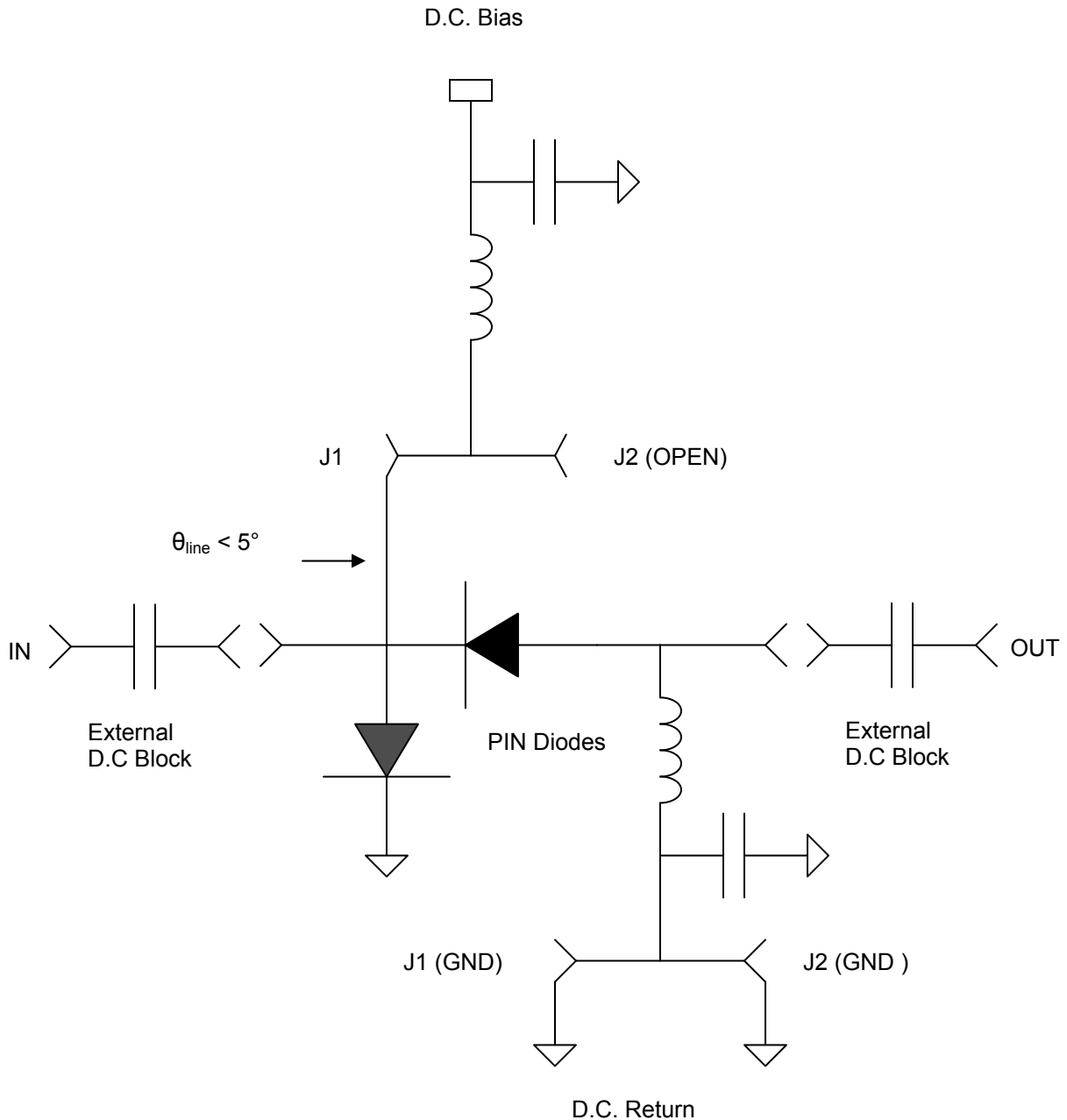

ADVANCED: Data Sheets contain information regarding a product MA-COM Technical Solutions is considering for development. Performance is based on target specifications, simulated results, and/or prototype measurements. Commitment to develop is not guaranteed.
PRELIMINARY: Data Sheets contain information regarding a product MA-COM Technical Solutions has under development. Performance is based on engineering tests. Specifications are typical. Mechanical outline has been fixed. Engineering samples and/or test data may be available. Commitment to produce in volume is not guaranteed.

- **North America** Tel: 800.366.2266 / Fax: 978.366.2266
- **Europe** Tel: 44.1908.574.200 / Fax: 44.1908.574.300
- **Asia/Pacific** Tel: 81.44.844.8296 / Fax: 81.44.844.8298

Visit www.macom.com for additional data sheets and product information.

MA-COM Technical Solutions and its affiliates reserve the right to make changes to the product(s) or information contained herein without notice.