

Silicon Double Balanced HMIC Mixer 700—1400 MHz

Rev. V1

Features

- + 3 to + 7 dBm
- Fully Balanced Passive Mixer
- NO External Matching Required
- Low Cost Surface Mount Package
- RoHS* Compliant with 260 °C Reflow Capability
- 100% Matte Tin Plating

Description

M/A-COM's MAMX-000900-1061LT is a silicon monolithic 700-1400 MHz, low barrier, double balanced mixer in a low cost surface mount SOIC-8 package. The die uses M/A-COM's unique HMIC silicon/glass process to realize low loss passive elements while retaining the advantages of low barrier silicon Schottky barrier diodes to produce a compact device.

Applications

These mixers are well suited for applications where small size and repeatability are required. Typical applications include frequency conversion, modulation, and demodulation in wireless receivers and transmitters.

SOIC-8 Package

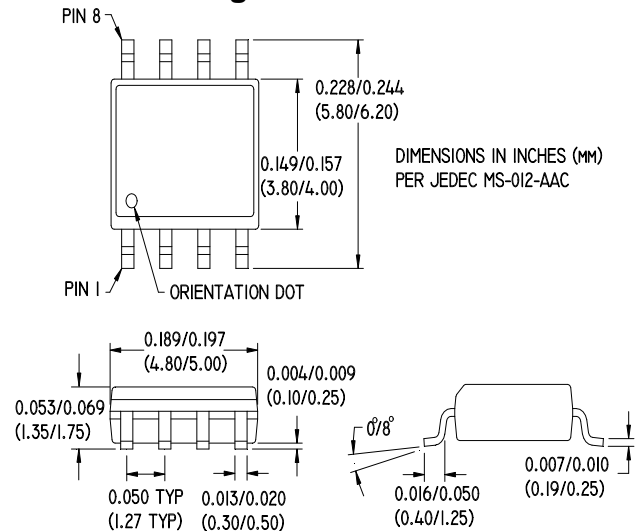

Pin Configuration

PIN	Function	PIN	Function
1	GND	5	LO
2	GND	6	GND
3	GND	7	GND
4	IF	8	RF

Ordering Information

Model No.	Package
MAMX-000900-1061LT	Tape and Reel

Absolute Maximum Ratings ^{1,2}

Parameter	Maximum Rating
Operating Temperature	-40°C to +85°C
Storage Temperature	-65°C to 125°C
Incident LO Power	+17 dBm
Incident RF Power	+17 dBm
Soldering Temperature	+260°C max.

1. Exceeding these limits may cause permanent damage.
2. Please refer to application note M538 for surface mounting instructions

Schematic

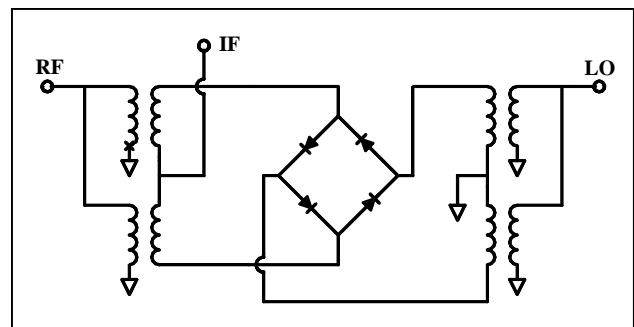

* Restrictions on Hazardous Substances, European Union Directive 2002/95/EC.

Electrical Specifications @ 25°C

Parameter	Frequency Range	Test Conditions	Units	Min.	Typ.	Max.
Conversion Loss	700-800 MHz	LO Drive = +7 dBm RF = -10 dBm, IF = 60 MHz	dB	-	6.7	9.5
	800-1000 MHz			-	6.0	8.0
	1000-1250 MHz				7.2	10.5
	1250-1400 MHz				9.2	12.0
L - R Isolation	700-1000 MHz	LO Drive = +7 dBm	dB	26	37.6	-
	1000-1400 MHz			24	32.1	-
L - I Isolation	700-1000 MHz	LO Drive = +7 dBm	dB	24	36.4	-
	1000-1400 MHz			21	32.1	-
LO VSWR	700-1000 MHz	LO Drive = +7 dBm RF Level = - 10 dBm	Ratio	-	1.7:1	-
	1000-1400 MHz			-	2.3:1	-
RF VSWR	700-1000 MHz	LO Drive = +7 dBm RF Level = - 10 dBm	Ratio	-	1.5:1	-
	1000-1400 MHz			-	2.4:1	-
IF VSWR	DC - 400 MHz	LO Drive = +7 dBm IF Level = - 10 dBm	Ratio	-	1.5:1	-
Input IP3	700-1000 MHz	LO Drive = +7 dBm RF = - 10 dBm, IF = 60 MHz	dBm	9.0	14.1	-
	1000-1400 MHz			10.5	16.1	-
Input 1 dB Compression	700-1000 MHz	LO Drive = +7 dBm IF = 60 MHz	dBm	-	1.9	-
	1000-1400 MHz			-	3.0	-

Typical Performance Curves (LO Drive= +5/+7/+9dbm, RF= -10dBm, IF= 60MHz)

Conversion Loss

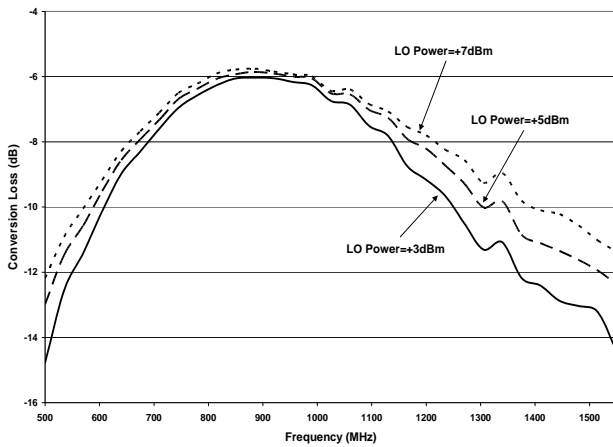

Input IP3

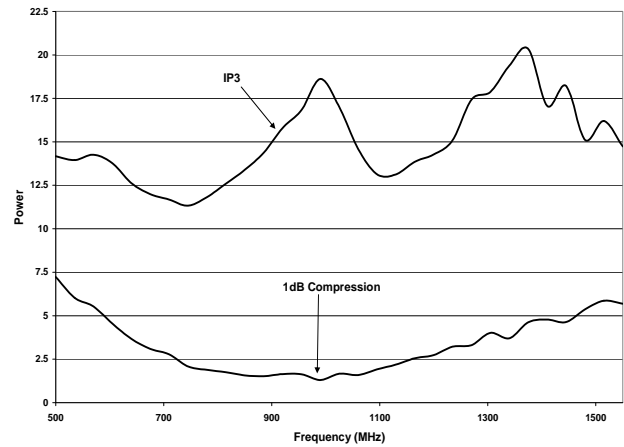

Isolation(LO Drive= +7dbm, RF= -10dBm)

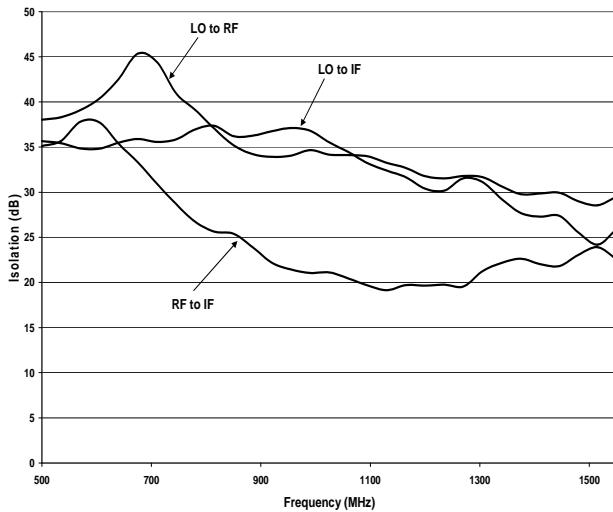

VSWR(LO Drive= +7dbm, RF= -10dBm, IF=-10dBm)

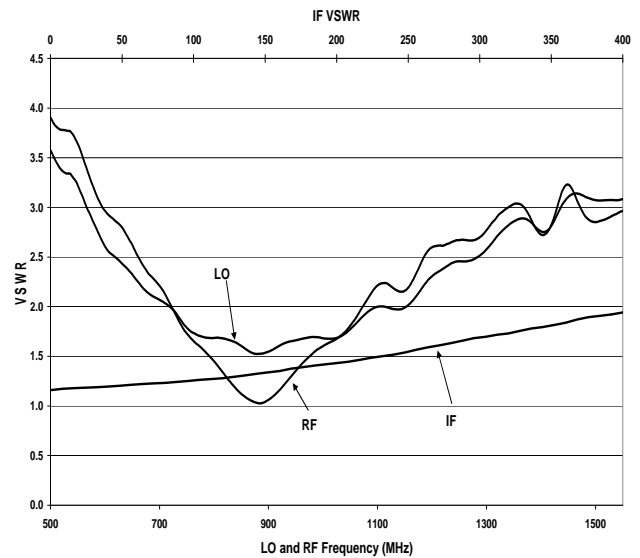

MAMX-000900-1061LT



Silicon Double Balanced HMIC Mixer
700—1400 MHz

Rev. V1

Spurious Table (in dBc below IF)

		nf _{LO} +mf _{RF}								
LO (n)	-4	-	-	-	-	-	-	-	-	-
	-3	-	-	-	-	-	-	-	-	77
	-2	-	-	-	-	-	-	-	60	80
	-1	-	-	-	-	-	-	44	66	77
	0	-	-	-	-	-	16	61	61	95
	1	-	-	-	0	13	2	42	78	89
	2	-	-	55	27	15	27	71	72	87
	3	-	58	45	13	6	36	51	65	91
	4	80	57	61	31	36	39	60	71	94
		-4	-3	-2	-1	0	1	2	3	4
		RF (m)								

RF=920MHz
 LO=980MHz