

MA4EX580L1-1225T



Silicon Double Balanced HMIC Mixer 4.7 - 6.0 GHz

M/A-COM Products
Rev. V1

Features

- 7.6 dB Typical Conversion Loss
- +3 to +7 dBm LO Drive
- HMIC™ Patented Process
- Silicon Low Barrier Schottky Diodes
- DC - 1050 MHz IF Bandwidth
- Low Cost Miniature Plastic Package
- **Lead Free and RoHS Compliant**

Description and Applications

M/A-COM's MA4EX580L1-1225T is a silicon monolithic 4.7 to 6.0 GHz double balanced mixer in a low cost miniature surface mount SOT-25 package. The die uses M/A-COM's unique HMIC™ silicon/glass process to achieve low loss passive elements while retaining the advantages of low barrier silicon Schottky diodes.

These mixers are well suited for high volume wireless and cellular applications where small size and repeatability are required. Typical applications include frequency conversion, modulation, and demodulation in wireless receivers and transmitters.

Package Outline (Topview)

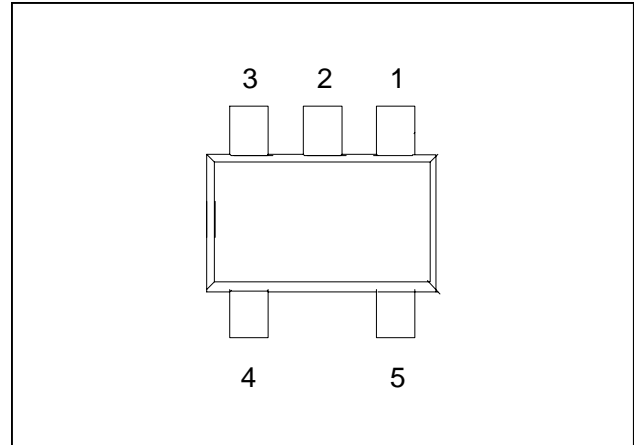

PIN Configuration

PIN	Function	PIN	Function
1	RF	4	GND
2	GND	5	IF
3	LO		

Ordering Information

Standard Part Number	Package
MA4EX580L1-1225T	Tape and Reel

Absolute Maximum Ratings¹

Parameter	Maximum Ratings
Operating Temperature	-40 °C to +85 °C
Storage Temperature	-65 °C to +150 °C
Incident LO Power	+20 dBm
Incident RF Power	+20 dBm

1. Exceeding these limits may cause permanent damage.
2. Refer to application note M538 for surface mounting instructions.

Schematic

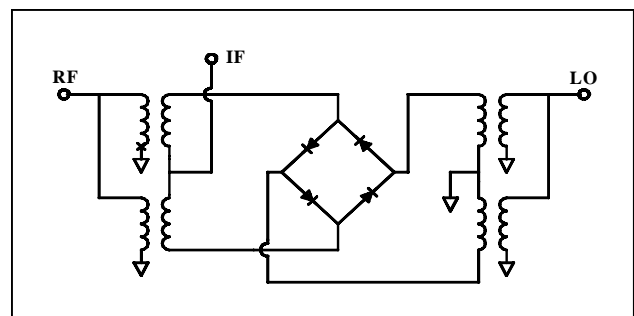

1

ADVANCED: Data Sheets contain information regarding a product M/A-COM Technology Solutions is considering for development. Performance is based on target specifications, simulated results, and/or prototype measurements. Commitment to develop is not guaranteed.
PRELIMINARY: Data Sheets contain information regarding a product M/A-COM Technology Solutions has under development. Performance is based on engineering tests. Specifications are typical. Mechanical outline has been fixed. Engineering samples and/or test data may be available. Commitment to produce in volume is not guaranteed.

• **North America** Tel: 800.366.2266 • **Europe** Tel: +353.21.244.6400
 • **India** Tel: +91.80.43537383 • **China** Tel: +86.21.2407.1588
 Visit www.macomtech.com for additional data sheets and product information.

M/A-COM Technology Solutions Inc. and its affiliates reserve the right to make changes to the product(s) or information contained herein without notice.

MA4EX580L1-1225T



Silicon Double Balanced HMIC Mixer 4.7 - 6.0 GHz

M/A-COM Products
Rev. V1

Electrical Specifications @ +25 °C

Parameter	Frequency Range	Test Conditions	Units	Typ.	Max.
Conversion Loss	4700 MHz 4.7—6.0 GHz	LO Drive = +3 -> +7 dBm RF = -10 dBm, IF = 60 MHz	dB dB	7.6	8.0
				8.5	9.5
L - R Isolation	4700 MHz 4.7—6.0 GHz	LO Drive = +5 dBm RF Level = -10 dBm	dB dB	23.0 20.0	
L - I Isolation	4700 MHz 4.7—6.0 GHz	LO Drive = +5 dBm RF Level = -10 dBm	dB dB	22.0 20.0	
R - I Isolation	4700 MHz 4.7—6.0 GHz	LO Drive = +5 dBm RF Level = -10 dBm	dB dB	9.4 7.5	
LO VSWR	4700 MHz 4.7—6.0 GHz	LO Drive = +5 dBm RF Level = -10 dBm		2.7	-
				2.8	-
RF VSWR	4700 MHz 4.7—6.0 GHz	LO Drive = +5 dBm RF Level = -10 dBm		2.3	-
				3.1	-
IF VSWR	DC - 1050 MHz	LO Drive = +5 dBm RF Level = -10 dBm		1.1	-
Input IP3	4700 MHz 4.7—6.0 GHz	LO Drive = +3 -> +7 dBm RF = -10 dBm, IF = 60 MHz	dBm dBm	7.5	
				8.1	
Input 1 dB Compression	4700 MHz 4.7—6.0 GHz	LO Drive = +3 -> +7 dBm RF = -10 dBm, IF = 60 MHz	dBm dBm	+1.6	-
				+1.5	-
IF 1 dB Bandwidth	DC - 1050 MHz	LO = 4650 MHz @+5dBm	MHz	1050	-

Typical Performance Curves

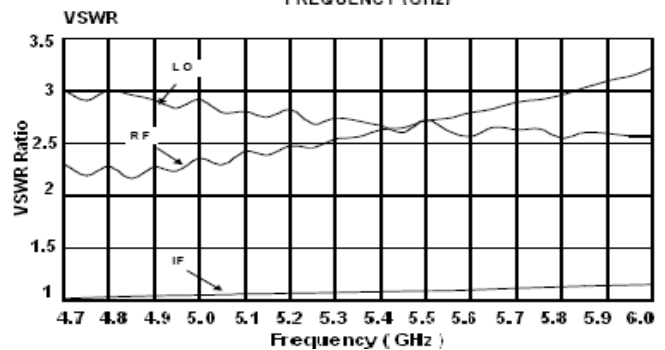
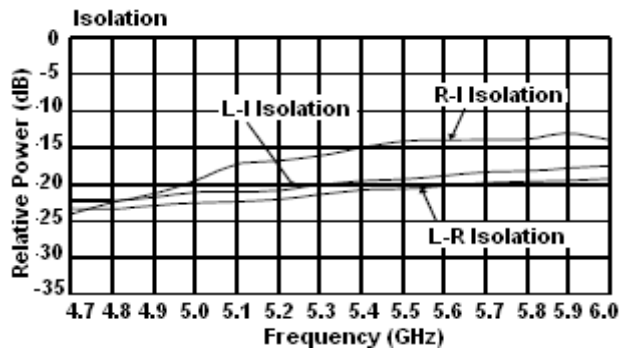
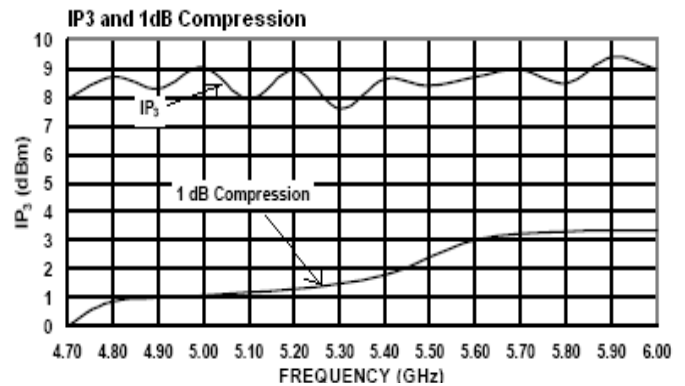
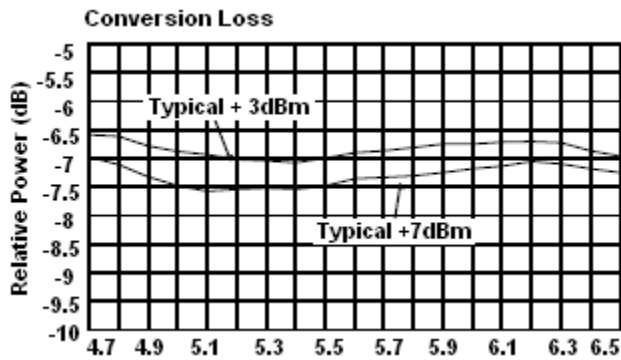

2 * Specifications subject to change without notice.

ADVANCED: Data Sheets contain information regarding a product M/A-COM Technology Solutions is considering for development. Performance is based on target specifications, simulated results, and/or prototype measurements. Commitment to develop is not guaranteed.
PRELIMINARY: Data Sheets contain information regarding a product M/A-COM Technology Solutions has under development. Performance is based on engineering tests. Specifications are typical. Mechanical outline has been fixed. Engineering samples and/or test data may be available. Commitment to produce in volume is not guaranteed.

• North America Tel: 800.366.2266 • Europe Tel: +353.21.244.6400
 • India Tel: +91.80.43537383 • China Tel: +86.21.2407.1588
 Visit www.macomtech.com for additional data sheets and product information.

M/A-COM Technology Solutions Inc. and its affiliates reserve the right to make changes to the product(s) or information contained herein without notice.

MA4EX580L1-1225T



Silicon Double Balanced HMIC Mixer
4.7 - 6.0 GHz

M/A-COM Products
Rev. V1

Case Style - SOT-25

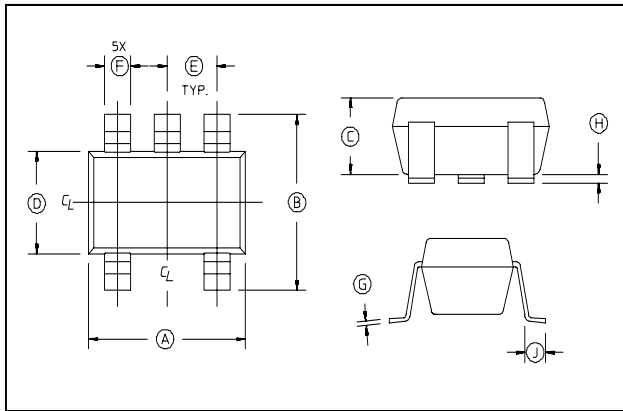

SOT-25 Dimensions

Dim	Inches		Millimeters	
	Min.	Max.	Min.	Max.
A	.106	.122	2.70	3.10
B	.100	.118	2.54	3.00
C	—	.051	—	1.30
D	.063 REF.		1.60 REF.	
E	.032	.043	.80	1.10
F	.014	.020	.35	.50
G	.003	—	.08	—
H	.000	.006	.00	.15
J	.018 REF.		.45 REF.	

2. Leads Coplanarity should be 0.003 (0.08) max.

ADVANCED: Data Sheets contain information regarding a product M/A-COM Technology Solutions is considering for development. Performance is based on target specifications, simulated results, and/or prototype measurements. Commitment to develop is not guaranteed.
PRELIMINARY: Data Sheets contain information regarding a product M/A-COM Technology Solutions has under development. Performance is based on engineering tests. Specifications are typical. Mechanical outline has been fixed. Engineering samples and/or test data may be available. Commitment to produce in volume is not guaranteed.

• **North America** Tel: 800.366.2266 • **Europe** Tel: +353.21.244.6400
 • **India** Tel: +91.80.43537383 • **China** Tel: +86.21.2407.1588
 Visit www.macomtech.com for additional data sheets and product information.

M/A-COM Technology Solutions Inc. and its affiliates reserve the right to make changes to the product(s) or information contained herein without notice.