

MA4EX240L1-1225T

Silicon Double Balanced HMIC Mixer 1700 - 2500 MHz

Rev. V2

Features

- Low Cost Miniature Plastic Package
- 6.4 dB Typical Conversion Loss at 2100 MHz
- 7.4 dB Typical Conversion Loss at 2400 MHz
- +3 to +7 dBm LO Drive
- HMIC™ Patented Process
- Silicon Low Barrier Schottky Diodes
- DC - 400 MHz IF Bandwidth
- RoHS* Compliant with 260 °C. Reflow Capability
- 100% MATTE Tin Plating

Description and Applications

M/A-COM's MA4EX240L1-1225T is a silicon monolithic 1700-2500 MHz double balanced mixer in a low cost miniature surface mount SOT-25 package. The die uses M/A-COM's unique HMIC™ silicon/glass process to achieve low loss passive elements while retaining the advantages of low barrier silicon Schottky diodes.

These mixers are well suited for high volume wireless and cellular applications where small size and repeatability are required. Typical applications include frequency conversion, modulation, and demodulation for receivers and transmitters in both portable cellular and base station applications.

Ordering Information

Standard Part Number	Package
MA4EX240L1-1225T	Tape and Reel

Absolute Maximum Ratings¹

Parameter	Maximum Ratings
Operating Temperature	-40 °C to +85 °C
Storage Temperature	-65 °C to +150 °C
Incident LO Power	+20 dBm
Incident RF Power	+20 dBm
Solder Temperature	+260 Deg C.

1. Exceeding these limits may cause permanent damage.

* Restrictions on Hazardous Substances, European Union Directive 2002/95/EC.

Package Outline (Topview)

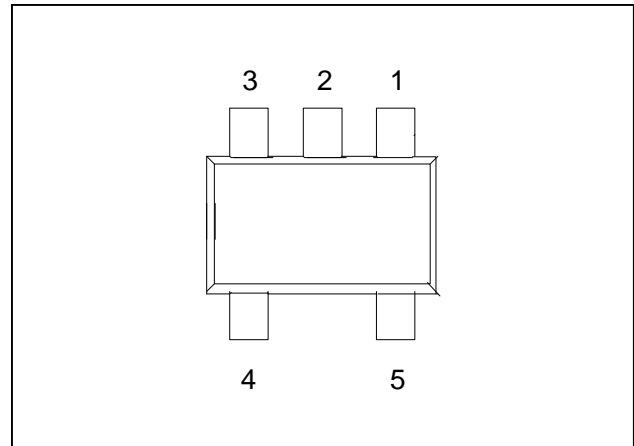

PIN Configuration

PIN	Function	PIN	Function
1	GND	4	RF
2	GND	5	LO
3	IF		

Schematic

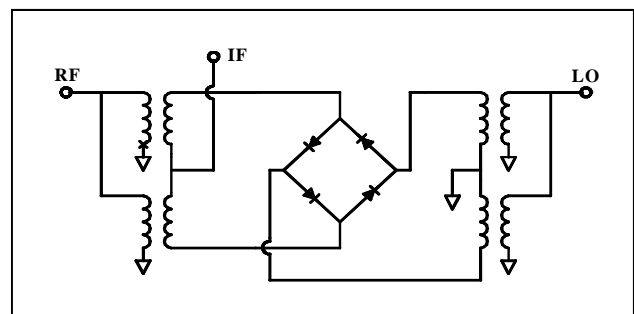

MA4EX240L1-1225T



Silicon Double Balanced HMIC Mixer 1700 - 2500 MHz

Rev. V2

Electrical Specifications @ +25 °C

Parameter	Frequency Range	Test Conditions	Units	Min.	Typ.	Max.
Conversion Loss	2100 MHz 1700-2500 MHz	LO Drive = +5 dBm RF = -10 dBm, IF = 60 MHz	dB dB		6.4 7.0	8.2 9.5
L - R Isolation	2100 MHz 1700-2500 MHz	LO Drive = +5 dBm RF Level = -10 dBm	dB dB	14 -	17.5 14.0	
L - I Isolation	2100 MHz 1700-2500 MHz	LO Drive = +5 dBm RF Level = -10 dBm	dB dB	- -	23.0 23.0	
R - I Isolation	2100 MHz 1700-2500 MHz	LO Drive = +5 dBm RF Level = -10 dBm	dB dB	- -	13.5 13.0	
LO VSWR	2100 MHz 1700-2500 MHz	LO Drive = +5 dBm RF Level = -10 dBm			2.1 2.1	- -
RF VSWR	2100 MHz 1700-2500 MHz	LO Drive = +5 dBm RF Level = -10 dBm			1.3 2.0	- -
IF VSWR	DC - 500 MHz	LO Drive = +5 dBm RF Level = -10 dBm			1.3	-
Input IP3	2100 MHz 1700-2500 MHz	LO Drive = +5 dBm IF = 60 MHz	dBm dBm	+10 +8	+13.0 +12.0	
Input 1 dB Compression	2100 MHz 1700-2500 MHz	LO Drive = +5 dBm IF = 60 MHz	dBm dBm		+1.0 +1.0	- -
IF 1 dB Bandwidth			MHz	-	400	-

Typical Performance Curves (LO Drive = +5 dBm, RF = -10 dBm, IF = 60 MHz)

Conversion Loss

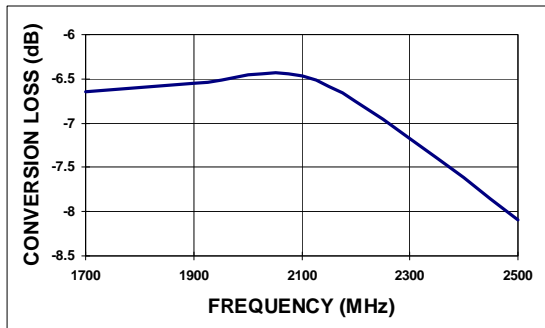

Input IP3 & 1dB Compression Point

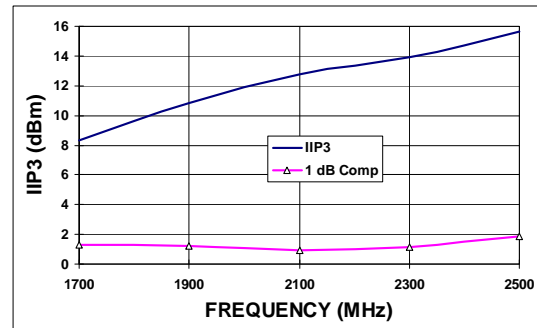

Isolation

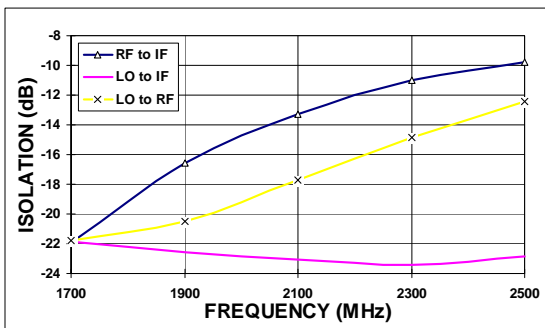

VSWR

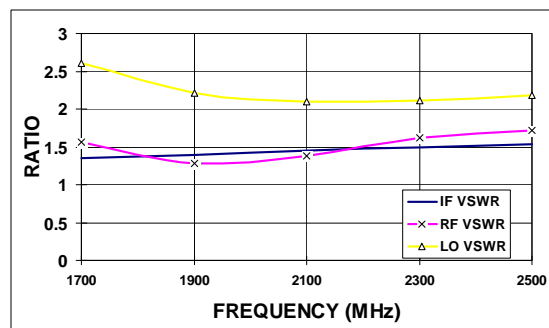

2

ADVANCED: Data Sheets contain information regarding a product M/A-COM Technology Solutions is considering for development. Performance is based on target specifications, simulated results, and/or prototype measurements. Commitment to develop is not guaranteed.
PRELIMINARY: Data Sheets contain information regarding a product M/A-COM Technology Solutions has under development. Performance is based on engineering tests. Specifications are typical. Mechanical outline has been fixed. Engineering samples and/or test data may be available. Commitment to produce in volume is not guaranteed.

• **North America** Tel: 800.366.2266 / Fax: 978.366.2266
 • **Europe** Tel: 44.1908.574.200 / Fax: 44.1908.574.300
 • **Asia/Pacific** Tel: 81.44.844.8296 / Fax: 81.44.844.8298
 Visit www.macomtech.com for additional data sheets and product information.

M/A-COM Technology Solutions Inc. and its affiliates reserve the right to make changes to the product(s) or information contained herein without notice.

MA4EX240L1-1225T

Silicon Double Balanced HMIC Mixer
1700 - 2500 MHz

Rev. V2

Case Style - SOT-25

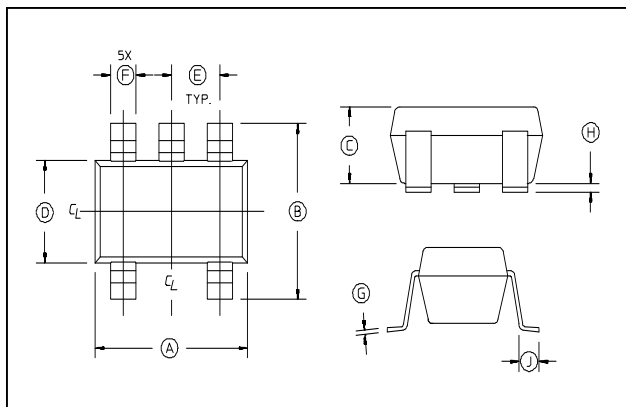

SOT-25 Dimensions

Dim	Inches		Millimeters	
	Min.	Max.	Min.	Max.
A	.106	.122	2.70	3.10
B	.100	.118	2.54	3.00
C	—	.051	—	1.30
D	.063 REF.		1.60 REF.	
E	.032	.043	.80	1.10
F	.014	.020	.35	.50
G	.003	—	.08	—
H	.000	.006	.00	.15
J	.018 REF.		.45 REF.	

2. Leads Coplanarity should be 0.003 (0.08) max.