

Features

- Integrated Gain, Doubler and Driver Stages
- +4.5 V Single Positive Bias
- Integrated Bypassing Capacitor
- +20 dBm Output Saturated Power
- 30 dBc Fundamental Suppression
- On-Chip ESD Protection
- 100% RF, DC and Output Power Testing
- Lead-Free 3 mm 16-Lead QFN Package
- RoHS* Compliant and 260°C Reflow Compatible

Description

The XX1010-QT is a 14.625-15.0 / 29.25-30.0 GHz GaAs MMIC doubler that integrates a gain stage, passive doubler and driver amplifier onto a single device. This device has a self-biased architecture requiring a single positive supply (+4.5V) only and integrated on-chip bypassing and DC blocking capacitors eliminating the need for any external components.

This device uses InGaAs pHEMT device technology, and is based upon electron beam lithography to ensure high repeatability and uniformity.

The XX1010-QT has integrated ESD structures for protection and comes in a low cost 3 mm QFN package.

The device is well suited for millimeter wave Point-to-Point Radio, LMDS, SATCOM and VSAT applications.

Ordering Information

Part Number	Package
XX1010-QT-0G00	Bulk Quantity
XX1010-QT-0G0T	1000 Piece Reel
XX1010-QT-EV1	Evaluation Board

Functional Block Diagram

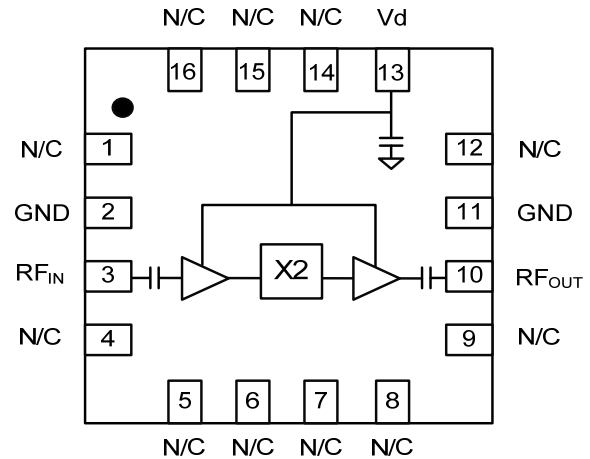

Pin Configuration¹

Pin No.	Function
1,4,5,6,7,8	No Connection
2,11	Ground
3	RF Input
9,12,14,15,16	No Connection
10	RF Output
13	Vd

1. The exposed pad centered on the package bottom must be connected to RF and DC ground.

* Restrictions on Hazardous Substances, European Union Directive 2002/95/EC.

Electrical Specifications: Input Freq: 14.625-15.0 GHz, T_A = 25°C, V_D = +4.5 Volts

Parameter	Units	Min.	Typ.	Max.
Output Frequency Range	GHz	29.25	-	30.0
RF Input Power Level	dBm	3.0	-	10.0
Input Return Loss	dB	-	12	-
Output Return Loss	dB	-	14	-
Fundamental Suppression	dBc	-	35	-
Output Power	dBm	+18.0	+20.0	+22.0
Supply Current	mA	-	200	280

Absolute Maximum Ratings^{2,3}

Parameter	Absolute Max.
Supply Voltage	+5.25 VDC
Supply Current	350 mA
Input Power	12 dBm
Storage Temperature	-65 to +150 °C
Operating Temperature	-40 to +85 °C
Junction Temperature ^{4,5}	+160 °C

- Exceeding any one or combination of these limits may cause permanent damage to this device.
- M/A-COM Technology Solutions does not recommend sustained operation near these survivability limits.
- Operating at nominal conditions with T_J ≤ 160°C will ensure MTTF > 1 x 10⁶ hours.
- Junction Temperature (T_J) = T_C + Θ_{JC} * ((V * I) - (P_{OUT} - P_{IN}))
Typical thermal resistance (Θ_{JC}) = 65°C/W.
a) For T_C = 25°C,
T_J = 101°C @ 4.5 V, 280 mA, P_{IN} = 3 dBm, P_{OUT} = 20 dBm
b) For T_C = 85°C,
T_J = 156°C @ 4.5 V, 264 mA, P_{IN} = 3 dBm, P_{OUT} = 20 dBm

Handling Procedures

Please observe the following precautions to avoid damage:

Static Sensitivity

Gallium Arsenide Integrated Circuits are sensitive to electrostatic discharge (ESD) and can be damaged by static electricity. Proper ESD control techniques should be used when handling these class 1A devices.

Typical Performance Curves:

P_{OUT} @ $2xFin$ vs. Fin @ $P_{IN} = 3$ dBm

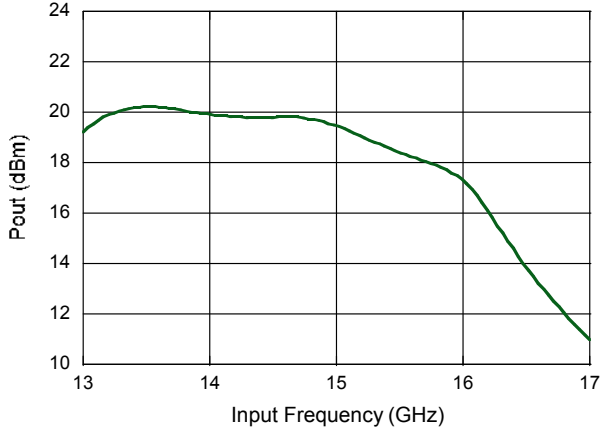

P_{OUT} @ $1xFin$ vs. Fin @ $P_{IN} = 3$ dBm

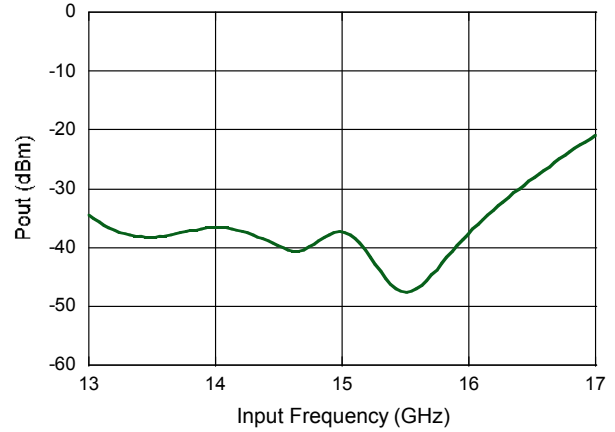

P_{OUT} @ $2xFin$ vs. Fin @ $P_{IN} = 10$ dBm

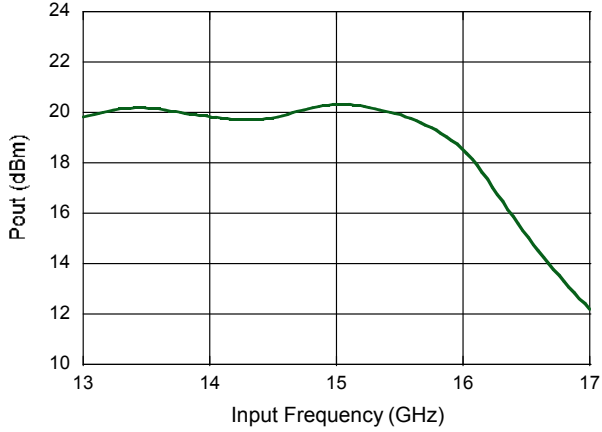

P_{OUT} @ $1xFin$ vs. Fin @ $P_{IN} = 10$ dBm

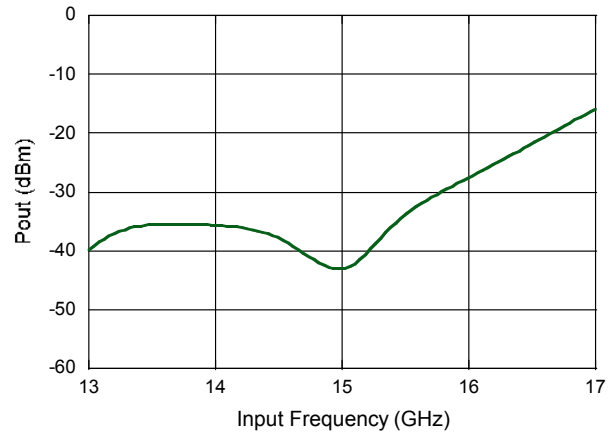

Typical Performance Curves:

Input Return Loss

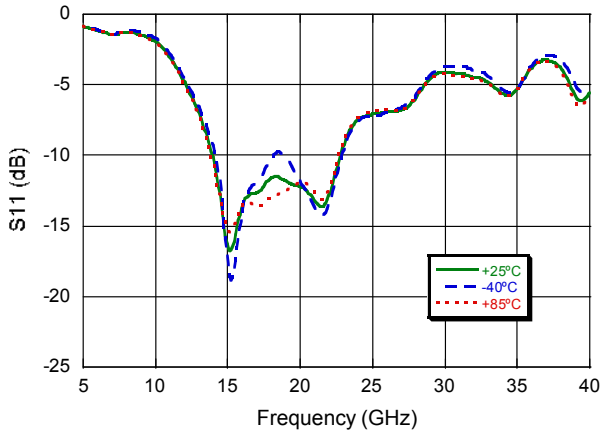

Output Return Loss

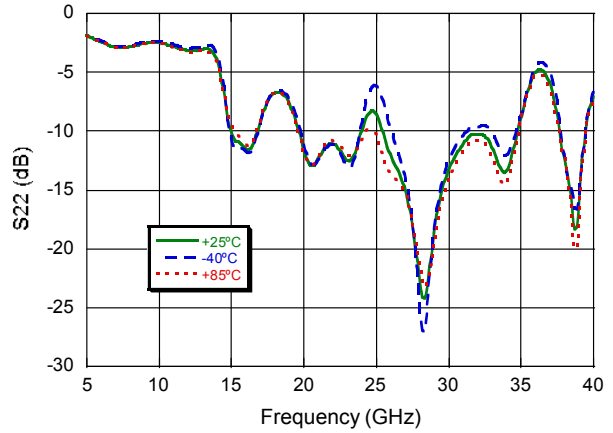

P_{OUT} vs. P_{IN}

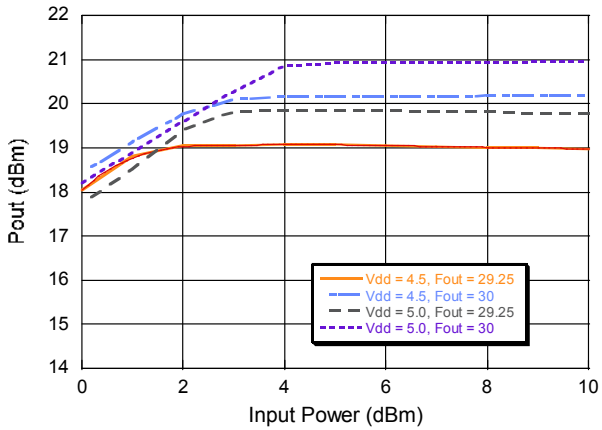

I_{ds} vs. P_{IN}

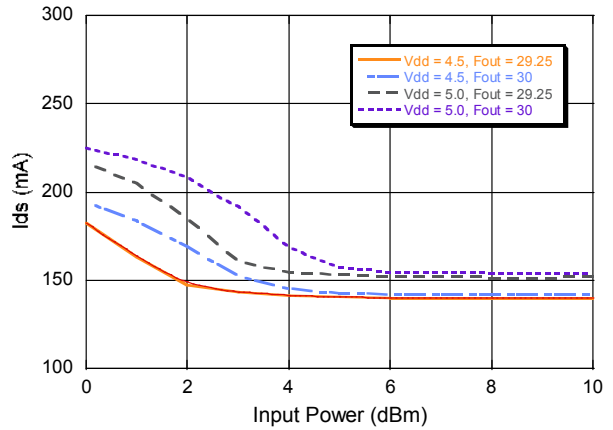

XX1010-QT

Doubler

14.625-15.0/29.25-30 GHz

Rev. V3

Evaluation Board Layout

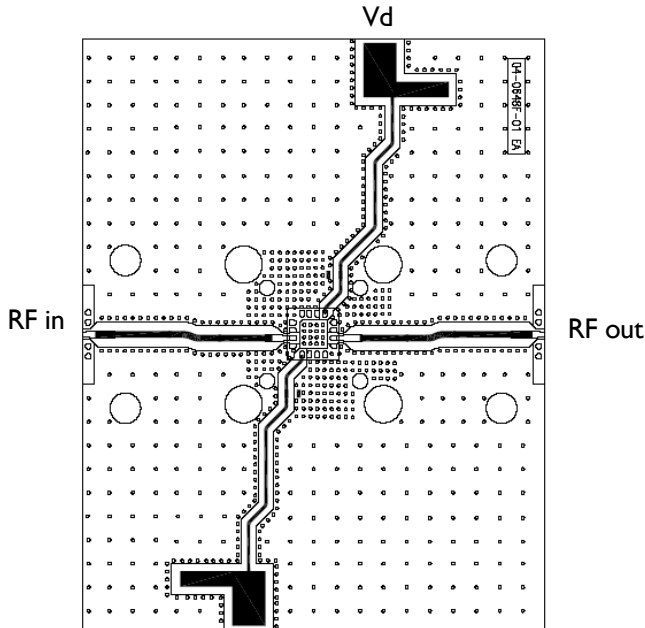

PCB Land Pattern

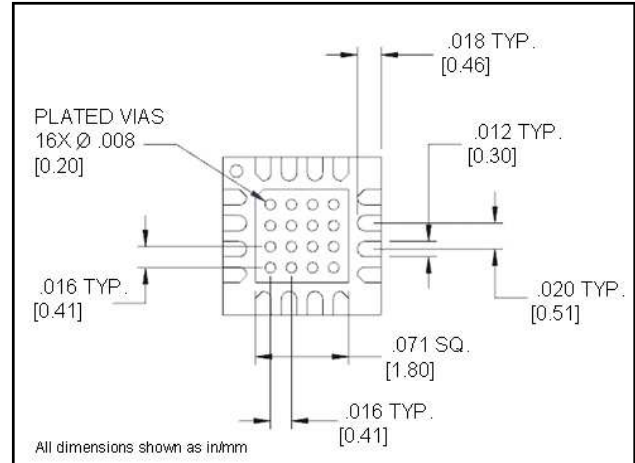

Lead-Free 3mm 16-Lead PQFN†

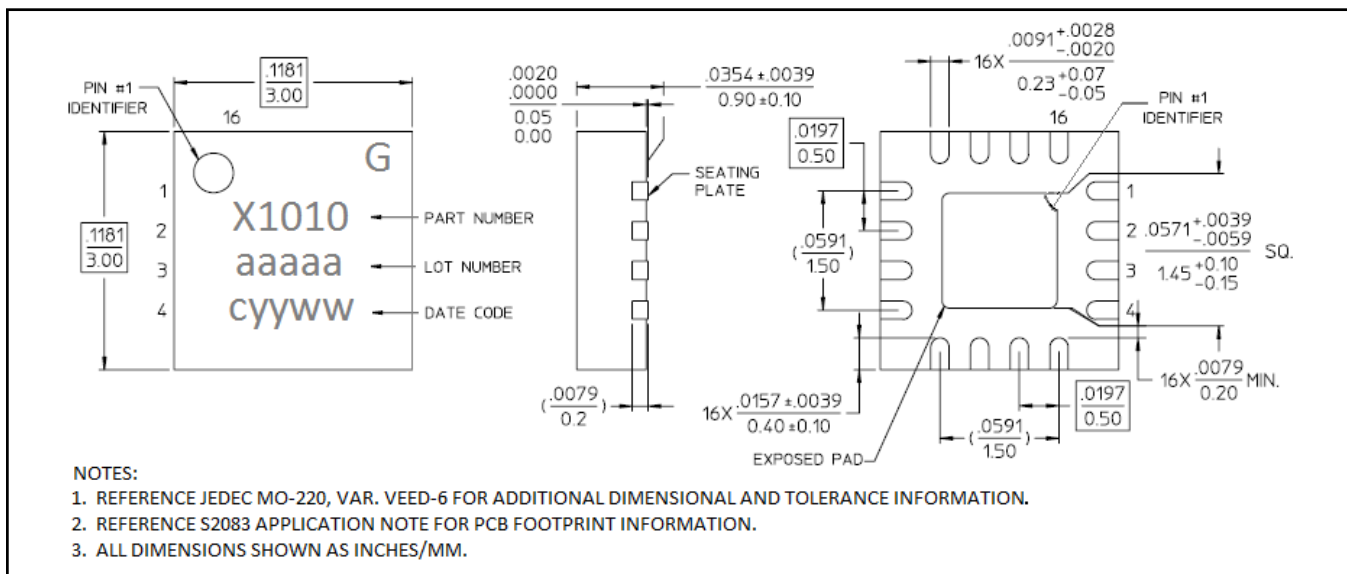

† Reference Application Note S2083 for lead-free solder reflow recommendations.
 Meets JEDEC moisture sensitivity level 1 requirements.
 Plating is 100% matte tin over copper.