

## Features

- Integrated Gain, Doubler and Driver Stages
- Single Positive Supply, +5V
- Integrated Bypassing Capacitor
- +20.0 dBm Output Saturated Power
- 35.0 dBc Fundamental Suppression
- On-Chip ESD Protection
- 100% RF, DC and Output Power Testing
- 3x3mm QFN Package
- RoHS\* Compliant and 260°C Reflow Compatible

## Description

M/A-COM Tech's 13.5-17.0 / 27.0-34.0 GHz GaAs MMIC doubler integrates a gain stage, passive doubler and driver amplifier onto a single device. The XX1007-QT has a self-biased architecture requiring a single positive supply (+5V) only and integrated on-chip bypassing and DC blocking capacitors eliminating the need for any external components. This device uses M/A-COM Tech's GaAs PHEMT device model technology, and is based upon electron beam lithography to ensure high repeatability and uniformity. The XX1007-QT has integrated ESD structures for protection and comes in a low cost 3x3mm QFN package. The device is well suited for Millimeter wave Point-to-Point Radio, LMDS, SATCOM and VSAT applications.

## Ordering Information

Part Number	Package
XX1007-QT-0G00	bulk quantity
XX1007-QT-0G0T	tape and reel
XX1007-QT-EV1	evaluation board

## Functional Block Diagram

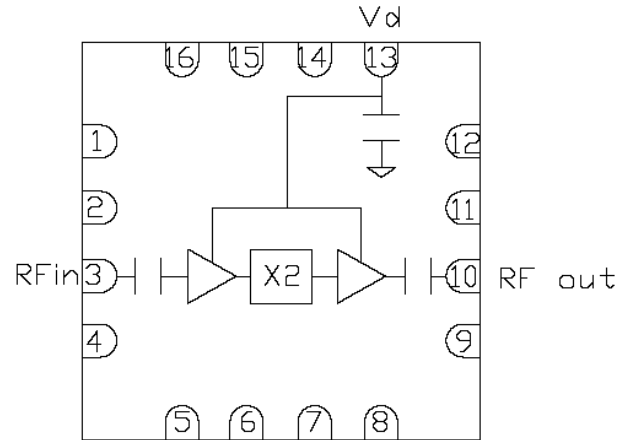

## Pin Configuration

Pin No.	Function	Pin No.	Function
3	RF In	1,2,4,5,6,7,8,9	NC
10	RF Out	11,12,14,15,16	NC
13	Vd		

## Absolute Maximum Ratings

Parameter	Absolute Max.
Supply Voltage (Vd)	+6.0 VDC
Supply Current (Id)	300 mA
Gate Bias Voltage (Vg)	+0.3 VDC
Input Power (RF Pin)	10 dBm
Storage Temperature (Tstg)	-65 to +165 °C
Operating Temperature (Ta)	-55 to MTTF Table <sup>1</sup>
Channel Temperature (Tch)	MTTF Table <sup>1</sup>

- (1) Channel temperature directly affects a device's MTTF. It is recommended to keep channel temperature as low as possible to maximize lifetime.

# XX1007-QT



**Doubler**  
**13.5-17.0/27.0-34.0 GHz**

Rev. V1  
MimiX Broadband

## Electrical Specifications: 13.5-17 GHz (fin) (Ambient Temperature T = 25°C)

Parameter	Units	Min.	Typ.	Max.
Output Frequency Range (fout)	GHz	27.0	-	34.0
Input Return Loss (S11)	dB	-	-8.0	-
Output Return Loss (S22)	dB	-	-10.0	-
Fundamental Suppression	dBc	-28.0	-35.0	-
RF Input Power (RF Pin)	dBm	-	8.0	-
Output Power at 8.0 dBm Pin (Pout)	dBm	+16.0	+20.0	-
Drain Bias Voltage (Vd)	VDC	-	+5.0	+5.5
Supply Current (Id1,2,3) (Vd=5.0V Typical)	mA	-	200	240

# XX1007-QT



**Doubler**  
13.5-17.0/27.0-34.0 GHz

Rev. V1  
MimiX Broadband

## Typical Performance Curves

XX1007-QT: Pout at Fin and 2X Fin, Pin = 10 dBm, Vd = 5V

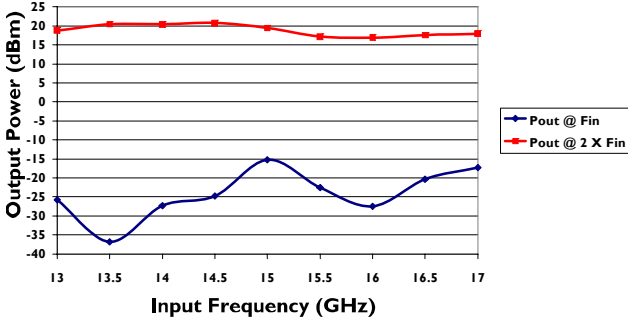

XX1007-QT: Pout at Fin and 2X Fin, Pin = 5 dBm, Vd = 5V

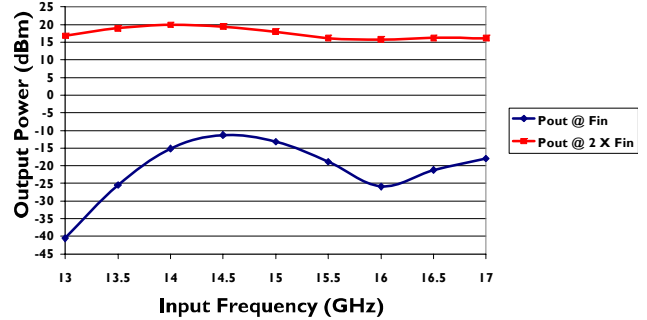

XX1007-QT: Pout at Fin and 2X Fin, Pin = 0 dBm, Vd = 5V

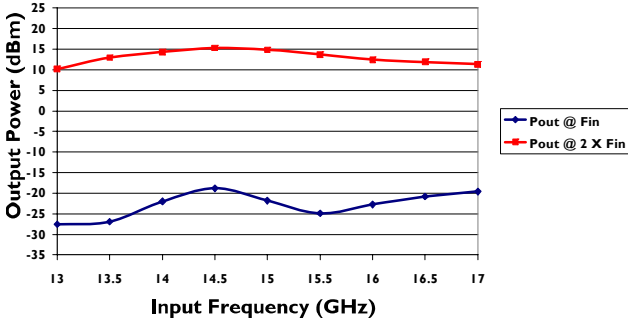

XX1007-QT: Pout at Fin and 2X Fin, Pin = 3 dBm, Vd = 5V

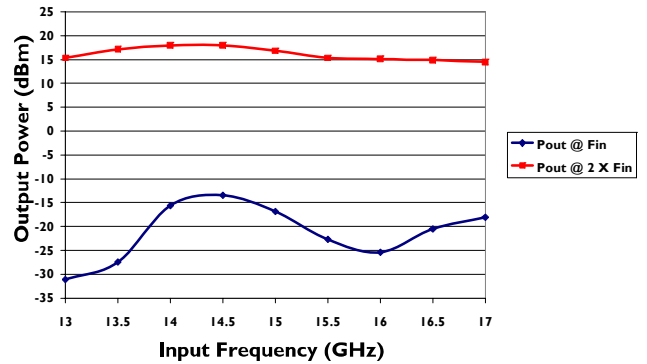

XX1007-QT: Pout Vs Pin, Vd = 5V, Input Frequency = 14.5 GHz

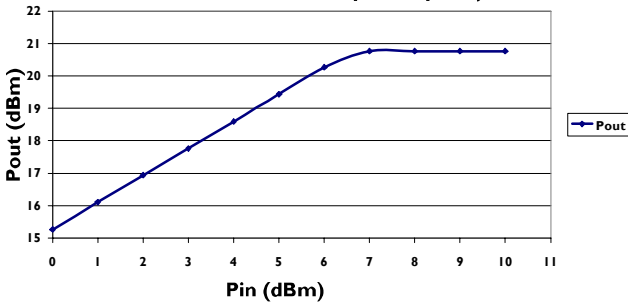

XX1007-QT: Pout Vs Pin, Input Frequency = 14.5 GHz

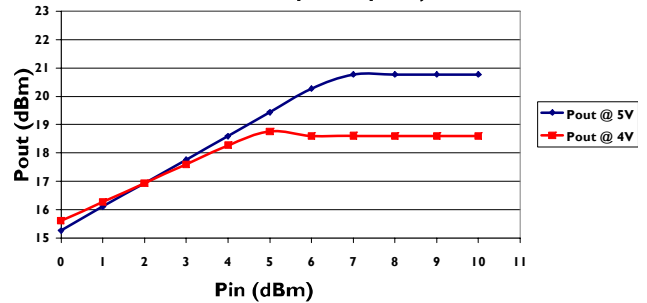

**ADVANCED:** Data Sheets contain information regarding a product M/A-COM Technology Solutions is considering for development. Performance is based on target specifications, simulated results, and/or prototype measurements. Commitment to develop is not guaranteed.  
**PRELIMINARY:** Data Sheets contain information regarding a product M/A-COM Technology Solutions has under development. Performance is based on engineering tests. Specifications are typical. Mechanical outline has been fixed. Engineering samples and/or test data may be available. Commitment to produce in volume is not guaranteed.

• **North America** Tel: 800.366.2266 • **Europe** Tel: +353.21.244.6400  
 • **India** Tel: +91.80.43537383 • **China** Tel: +86.21.2407.1588  
 Visit [www.macomtech.com](http://www.macomtech.com) for additional data sheets and product information.

M/A-COM Technology Solutions Inc. and its affiliates reserve the right to make changes to the product(s) or information contained herein without notice.

# XX1007-QT



**Doubler**  
13.5-17.0/27.0-34.0 GHz

Rev. V1  
MimiX Broadband

## Typical Performance Curves

XX1007-QT: Idd Vs Pin, Input Frequency = 14.5 GHz

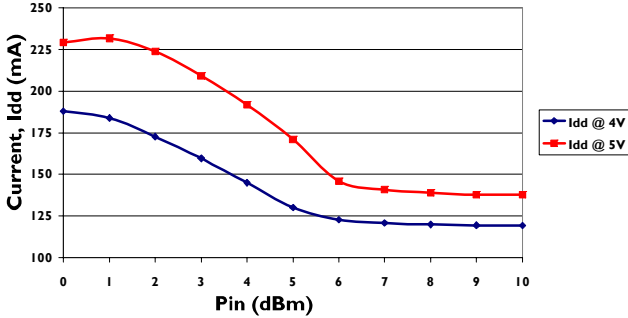

XX1007-QT: Idd Vs Input Frequency, Vd = 5V

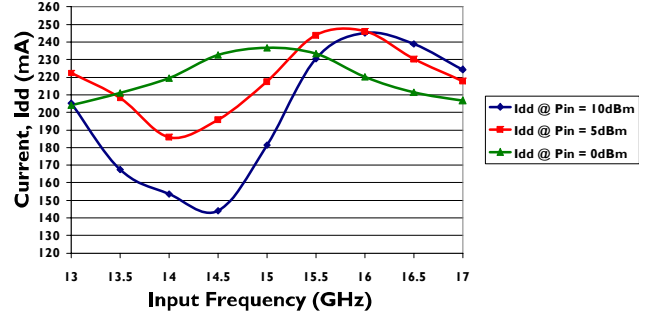

XX1007-QT: Input Return Loss (S11)

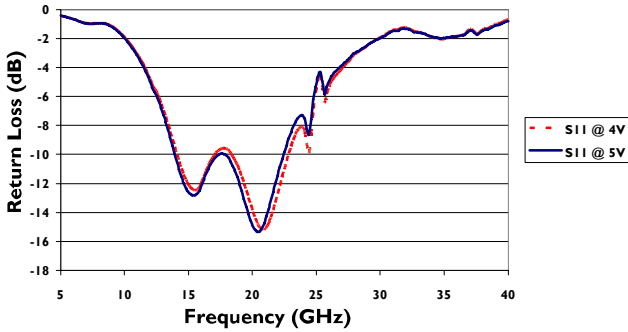

XX1007-QT: Input Return Loss (S22)

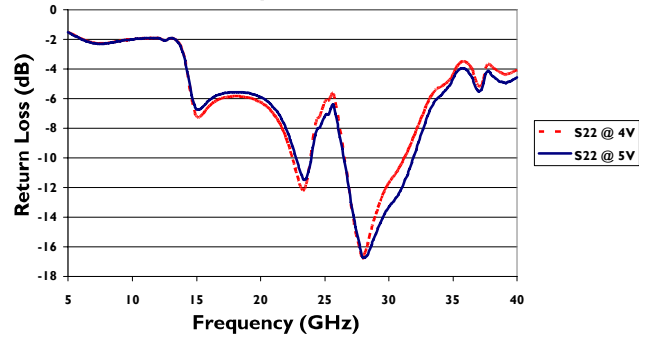

XX1007-QT: Input Return Loss (S11)

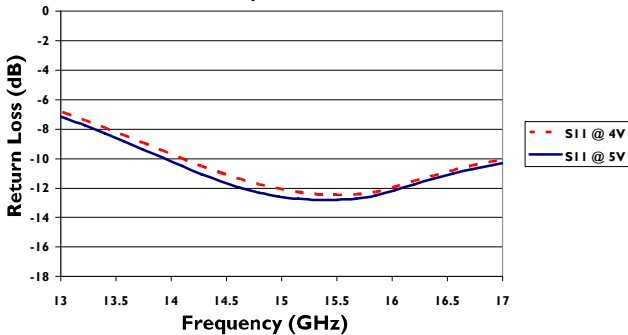

XX1007-QT: Input Return Loss (S22)

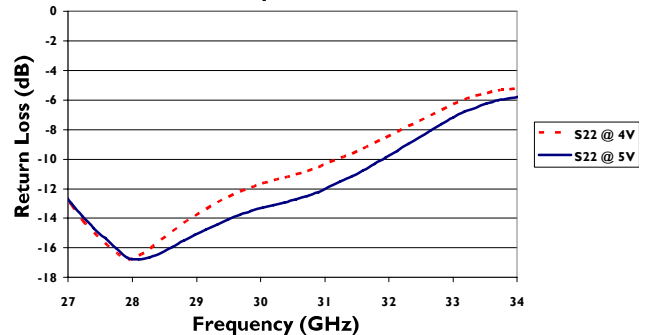

# XX1007-QT

**Doubler**  
13.5-17.0/27.0-34.0 GHz

Rev. V1  
MimiX Broadband

## Evaluation Board Layout

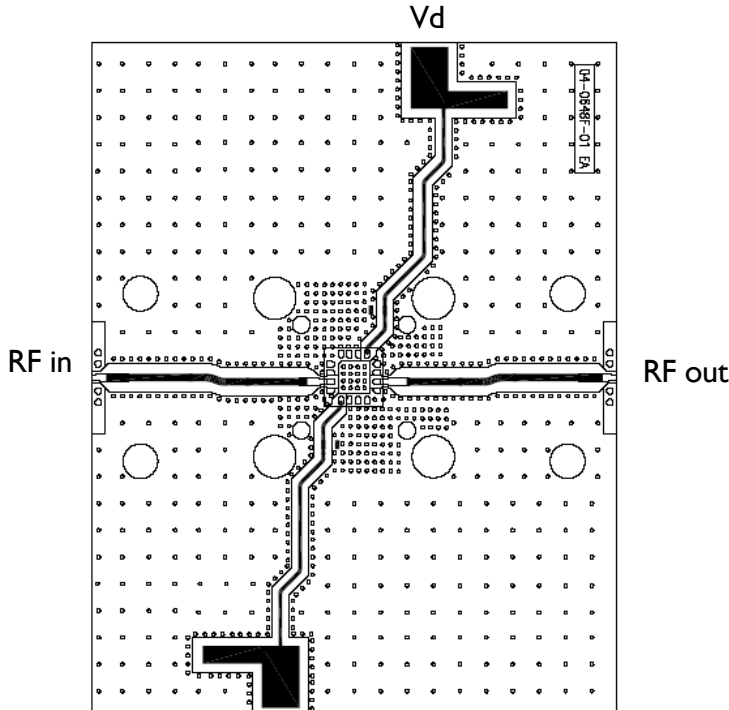

## MTTF Tables (TBD)

These numbers were calculated based on accelerated life test information and thermal model analysis received from the fabricating foundry.

Backplate Temperature	Channel Temperature	Rth	MTTF Hours	FITs
75 deg Celsius	192 deg Celsius	126 C/W	3.4 E+06	2.9 E+02

**Bias Conditions:** Vd=5.0V, Id=200mA

## Lead-Free Package Dimensions/Layout

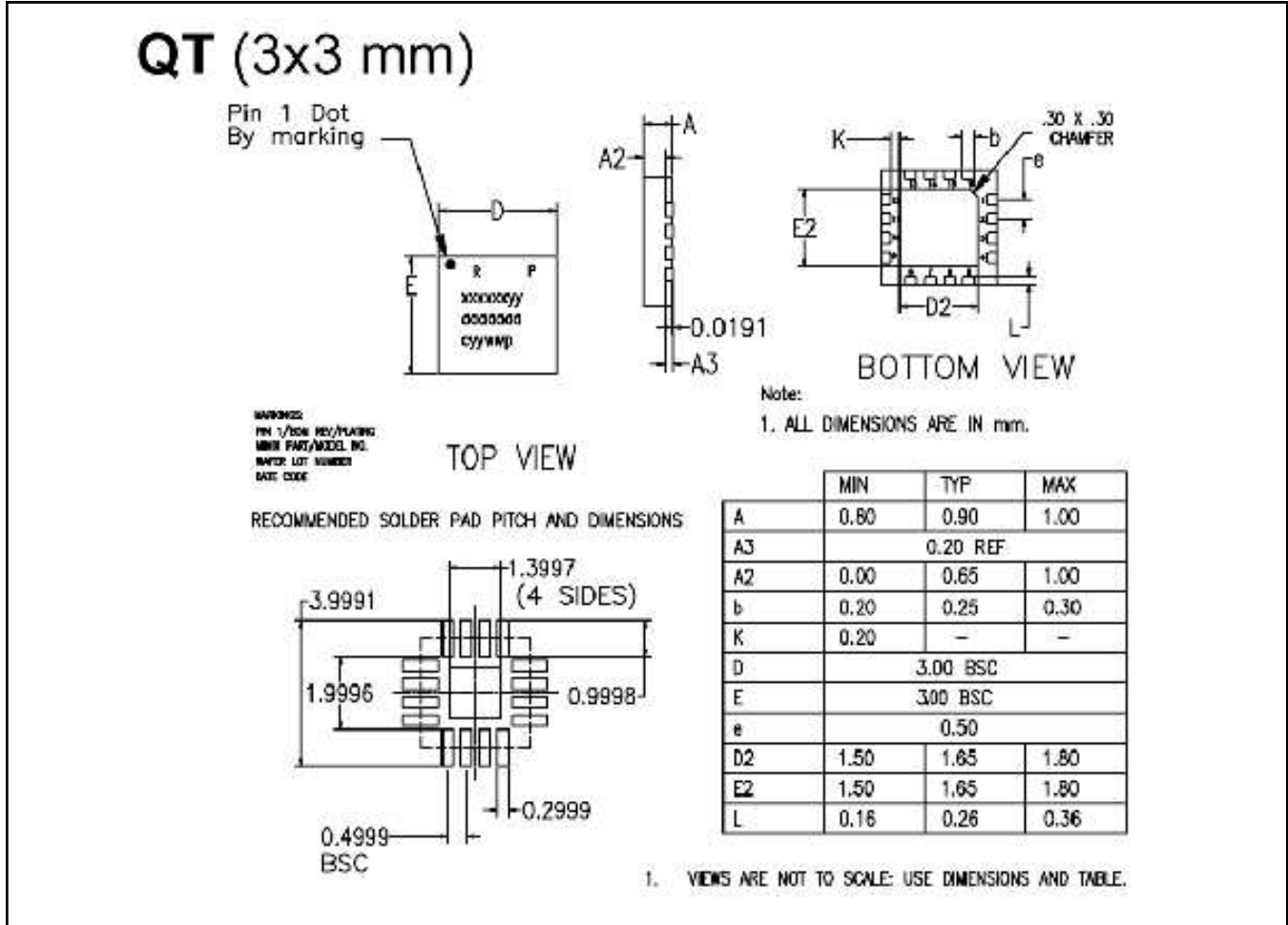

### Handling Procedures

Please observe the following precautions to avoid damage:

### Static Sensitivity

Gallium Arsenide Integrated Circuits are sensitive to electrostatic discharge (ESD) and can be damaged by static electricity. Proper ESD control techniques should be used when handling these class 2 devices.