

Features

- Lower Series Resistance : 2.6 Ω
- Lower Capacitance : 40 fF
- Faster Switching Speed : 40 nS
- Silicon Nitride Reliability Passivation
- Polyimide Scratch Protection
- Designed for Automated Pick and Place Insertion
- Rugged by Design

Description

M/A-COM's MA4FCP Series consists of Silicon Flip Chip PIN diodes fabricated with M/A-COM's patented HMIC process. This diode is fabricated on epitaxial wafers using a process designed for repeatable electrical characteristics and extremely low parasitics. This diode is fully passivated with Silicon Nitride and has an additional layer of Polyimide for scratch protection. These protective coatings prevent damage to the junction during automated or manual handling. This flip chip configuration is suitable for pick and place insertion.

Applications

The small 0315 outline and low 0.12 pS RC product, make the device useful for multi-throw switch and switched phase shifter circuits requiring < 40 nS switching speeds up to 18 GHz operating frequency.

Absolute Maximum Ratings @ 25 °C ¹

| Parameter | Absolute Maximum |
|-----------------------|-------------------------|
| Forward Current | 100 mA |
| Reverse Voltage | - 100 V |
| Operating Temperature | - 55 °C to + 125 °C |
| Storage Temperature | - 55 °C to + 150 °C |
| Junction Temperature | + 175 °C |
| Dissipated Power | 150 mW |
| Mounting Temperature | + 300 °C for 10 seconds |

1. Exceeding these limits may cause permanent damage.

1269 Outline

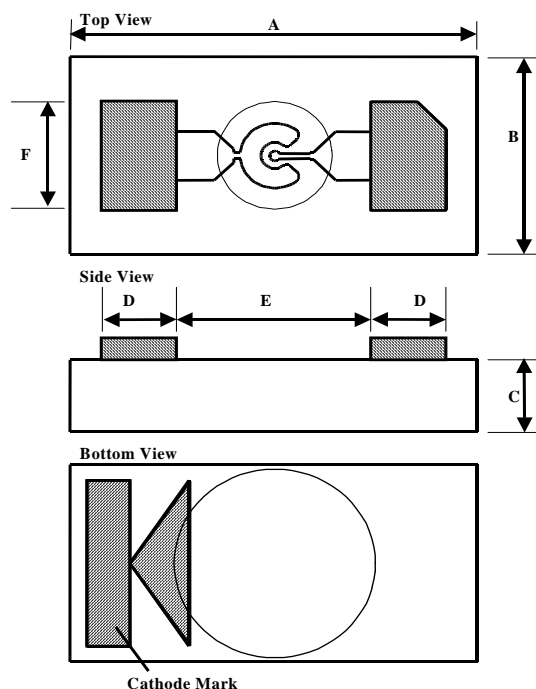

| Dim | inches | | (mm) | |
|-----|--------|--------|-------|-------|
| | min. | max. | min. | max. |
| A | 0.0269 | 0.0289 | 0.683 | 0.733 |
| B | 0.0135 | 0.0155 | 0.343 | 0.393 |
| C | 0.0040 | 0.0080 | 0.102 | 0.203 |
| D | 0.0041 | 0.0061 | 0.105 | 0.155 |
| E | 0.0124 | 0.0144 | 0.315 | 0.365 |
| F | 0.0069 | 0.0089 | 0.175 | 0.225 |

Electrical Specifications @ T_A = +25°C

| Parameters @ Conditions | Symbol | Units | Min. | Typ. | Max. |
|---|----------------|-------|------|-------|------|
| Total Capacitance @ -10V, 1MHz ¹ | C _T | pF | | 0.04 | 0.08 |
| Total Capacitance @ -10V, 1GHz ^{1,3} | C _T | pF | | 0.025 | |
| Series Resistance @ +50mA ^{2,3} , 100MHz | R _S | Ω | | 2.1 | 2.8 |
| Series Resistance @ +50mA ^{2,3} , 1GHz | R _S | Ω | | 2.6 | |
| Forward Voltage @ +100mA | V _F | V | | 1.1 | 1.5 |
| Reverse Voltage @ -10μA | V _R | V | -70 | -100 | |
| Reverse Current @ -40V | I _R | μA | | | - 10 |
| 50 – 90 % Lifetime @ + 10mA / - 6mA | TL | ns | | 140 | |
| Steady State Thermal Resistance ⁴ | θ | ° C/W | | 450 | |

1. Total capacitance is equivalent to the sum of junction capacitance C_j and parasitic capacitance, C_p.
2. Series resistance R_S is equivalent to the total diode series resistance including the junction resistance R_j.
3. R_s and C_p measured on an HP4291A with die mounted in an ODS-186 package.
4. Steady-State Thermal Resistance measured with die mounted in an ODS-186 package.

Assembly Procedures

The following precautions should be observed to avoid damaging these devices.

Cleanliness

These devices should be handled in a clean environment. Do not attempt to clean die after installation.

ESD

These devices very susceptible to ESD and are rated Class 0 (0-199V) per HBM MIL-STD-883, method 3015.7 [C = 100pF ±10%, R = 1.5kΩ ±1%]. Even though tested die pass 100V ESD, they must be handled in a static-free environment.

General Handling

The protective polymer coating on the active areas of these devices provides scratch protection, particularly for the metal airbridge that contacts the anode. Die can be handled with tweezers or vacuum pickups and are suitable for use with automatic pick-and-place equipment.

Mounting Techniques

These devices were designed for insertion onto hard or soft substrates with the junction side down. They can be mounted with electrically conductive epoxy or with a low temperature solder preform. The die can also be assembled with the junction side up, and wire or ribbon bonds made to the pads.

Solder Die Attach using Electrically Conductive Ag Epoxy and Solder

These chips are designed to be inserted onto hard or soft substrates with the junction side down. They should be mounted onto silkscreened circuits using Electrically Conductive Ag Epoxy, approximately 1-2 mils in thickness and cured at approximately 90°C to 150 °C per manufacturer's schedule. For extended cure times > 30 minutes, temperatures must be below 200 °C.

Sn Rich Solders (> 30 % by Weight) are not recommended due to the Tungsten Metallization scheme beneath the gold contacts. Indalloy or 80 Au/20 Sn Solders are acceptable. Maximum soldering temperature must be < 300 °C for < 10 seconds.

MA4FCP300



Silicon Flip Chip
PIN Diode

Rev. V1

Circuit Mounting Dimensions (Inches)

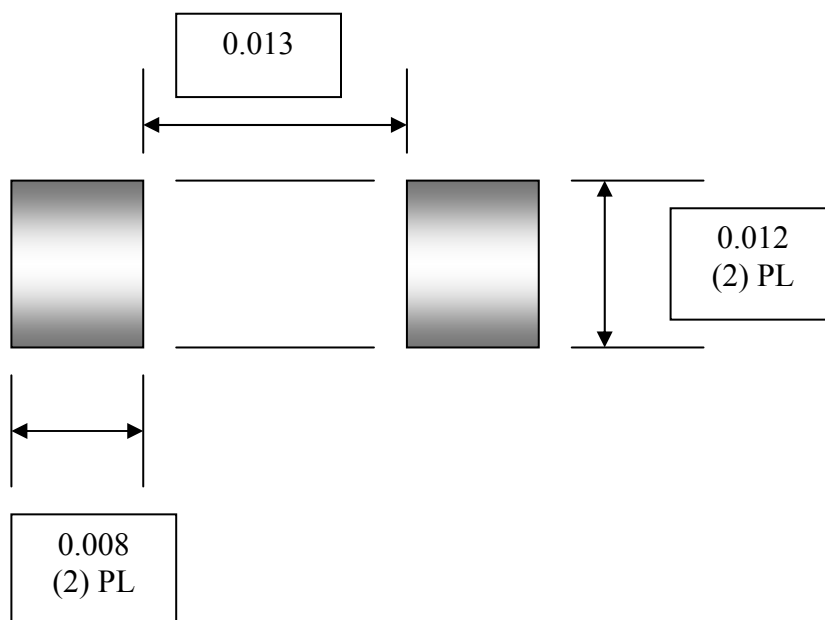

Ordering Information

| Part Number | Packaging |
|-------------|----------------|
| MA4FCP300 | Die in Carrier |
| MA4FCP300-T | Tape/Reel |
| MA4FCP300-W | Wafer on Frame |

ADVANCED: Data Sheets contain information regarding a product M/A-COM Technology Solutions is considering for development. Performance is based on target specifications, simulated results, and/or prototype measurements. Commitment to develop is not guaranteed.
PRELIMINARY: Data Sheets contain information regarding a product M/A-COM Technology Solutions has under development. Performance is based on engineering tests. Specifications are typical. Mechanical outline has been fixed. Engineering samples and/or test data may be available. Commitment to produce in volume is not guaranteed.

• **North America** Tel: 800.366.2266 • **Europe** Tel: +353.21.244.6400
• **India** Tel: +91.80.43537383 • **China** Tel: +86.21.2407.1588
Visit www.macomtech.com for additional data sheets and product information.

M/A-COM Technology Solutions Inc. and its affiliates reserve the right to make changes to the product(s) or information contained herein without notice.

MA4FCP300



Silicon Flip Chip
PIN Diode

Rev. V1

Capacitance vs Frequency

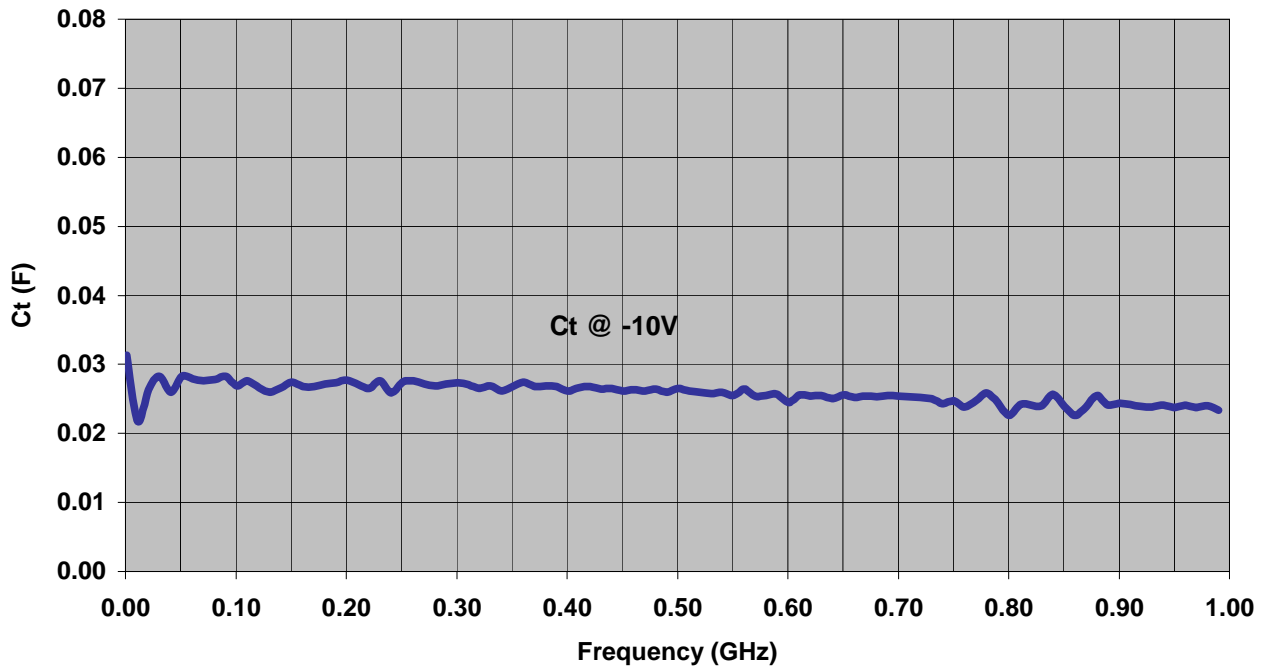

Rs vs Frequency

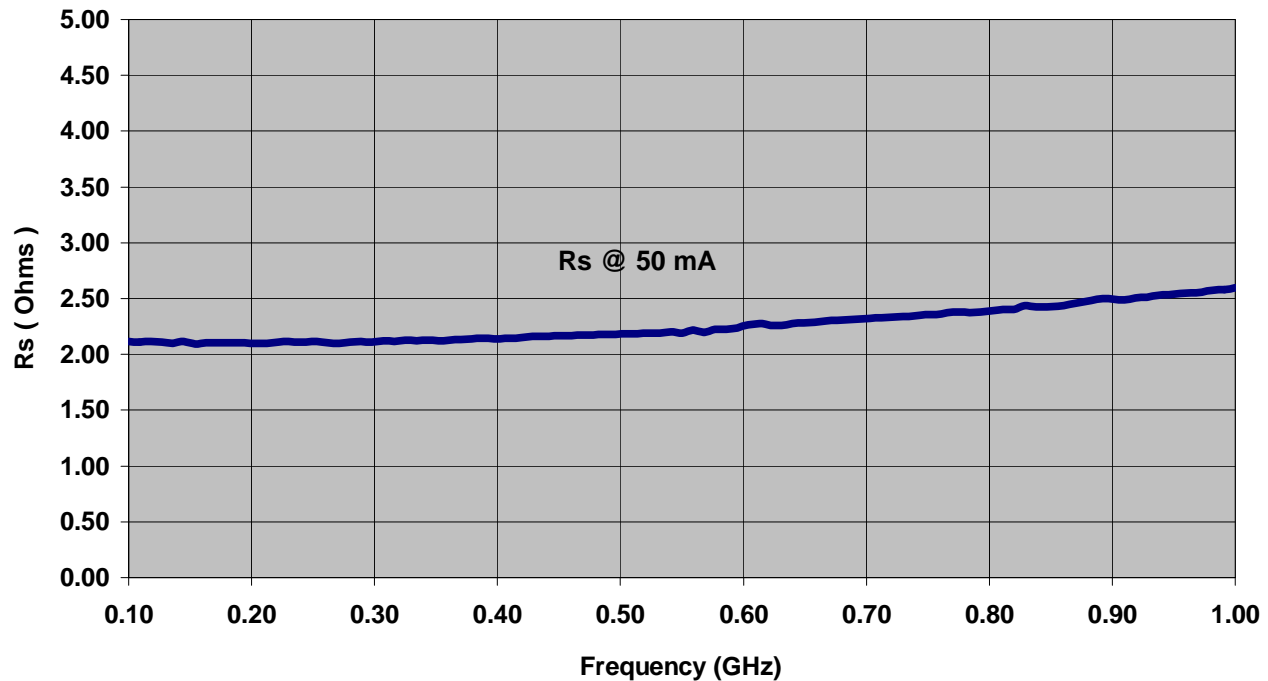

ADVANCED: Data Sheets contain information regarding a product M/A-COM Technology Solutions is considering for development. Performance is based on target specifications, simulated results, and/or prototype measurements. Commitment to develop is not guaranteed.
PRELIMINARY: Data Sheets contain information regarding a product M/A-COM Technology Solutions has under development. Performance is based on engineering tests. Specifications are typical. Mechanical outline has been fixed. Engineering samples and/or test data may be available. Commitment to produce in volume is not guaranteed.

• **North America** Tel: 800.366.2266 • **Europe** Tel: +353.21.244.6400
• **India** Tel: +91.80.43537383 • **China** Tel: +86.21.2407.1588
Visit www.macomtech.com for additional data sheets and product information.

M/A-COM Technology Solutions Inc. and its affiliates reserve the right to make changes to the product(s) or information contained herein without notice.

Diode Model

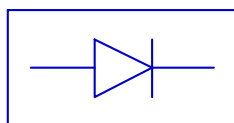
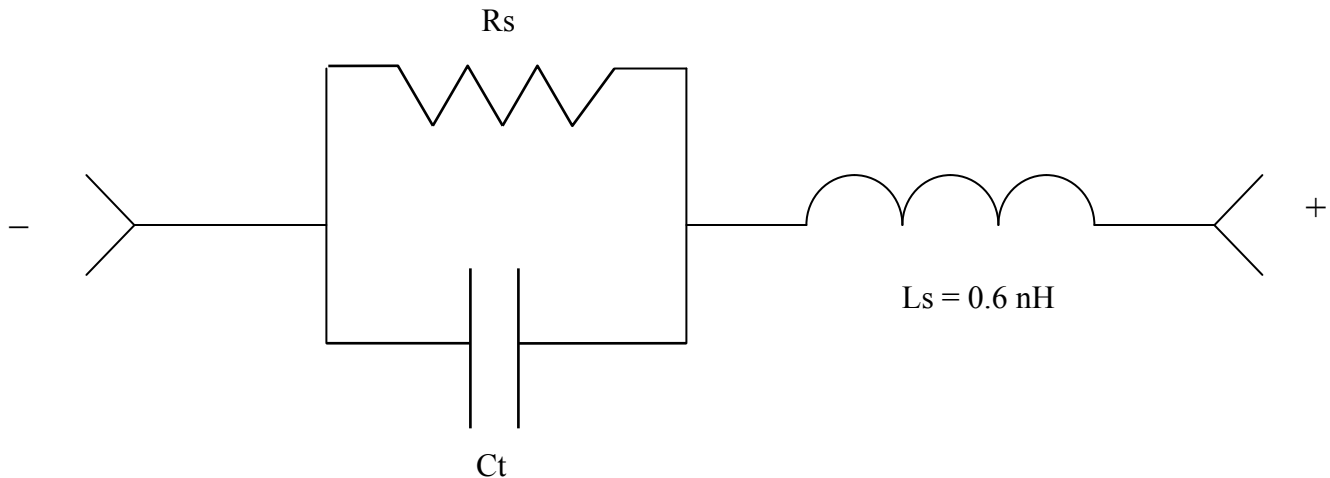

MA4FCP300 SPICE Model

PinDiodeModel

NLPINM1

Is=1.0E-14 A

Vi=0.0 V

Un= 900 cm²/V-sec

Wi= 7.5 um

Rr= 20 K Ohms

Cjmin= 0.04 pF

Tau= 0.14 usec

Rs(l)= Rc + Rj(l) = 0.05 Ohm + Rj(l)

Cj0= 0.07 pF

Vj= 0.7 V

M= 0.5

Fc= 0.5

Imax= 1.0 E+5 A/m²

Kf=0.0

Af=1.0

wBv= 100 V

wPmax= 125 mW

Ffe= 1.0

AllParams=