

Features

- Input IP3: +35 dBm Min. (Full Attenuation Range)
- Input IP3 is **15 -20 dB** Better Than GaAs
- Linear Operation: +20 dBm Typ.
- 38 dB Dynamic Range (With 30 mA Bias Current)
- Single Control Voltage
- 50 ohm Impedance
- Linear Driver, DR65-0002, Available
- Test Boards are Available
- Tape and Reel Packaging Available
- SOW-16 Package

Description

M/A-COM's AT10-0009 is a PIN diode based voltage variable attenuator. This device is in a SOW-16, wide body plastic surface mount package. These attenuators have linear operating power and input intercept point levels 15 - 20 dB better than GaAs FET MMIC voltage variable attenuators. They are ideally suited for use where low distortion, high linear operating power and high dynamic range are required. These devices are optimized for the GSM frequency band, but exhibit excellent performance and repeatability over the entire specified frequency band. The AT10-0009 is ideally suited for wireless communications systems.

Functional Schematic

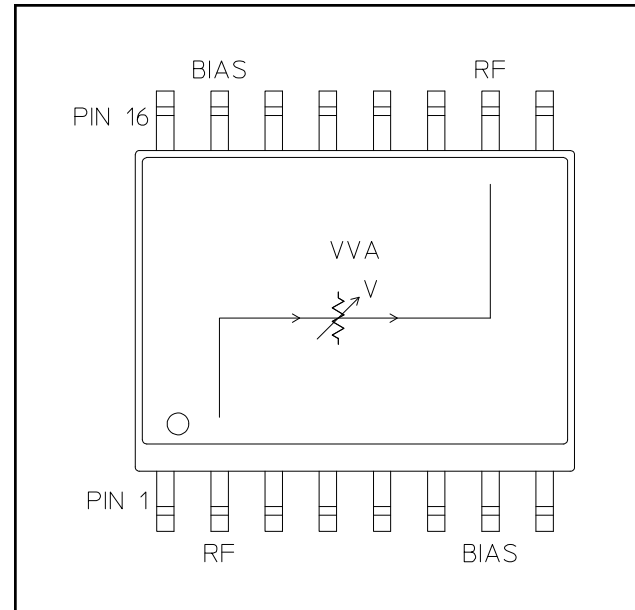

Pin Configuration

Pin No.	Function	Pin No.	Function
1	GND	9	GND
2	RF	10	RF
3	GND	11	GND
4	GND	12	GND
5	GND	13	GND
6	GND	14	GND
7	Bias ¹	15	Bias ¹
8	GND	16	GND

1. Bias currents may be applied to pin 7 or 15. The unused pin should be isolated.

Ordering Information

Part Number	Package
AT10-0009	Bulk Packaging
AT10-0009TR	1000 piece reel
AT10-0009-TB	Sample Test Board
DR65-0002-TBG	Unit with Driver on Test Board

Note: Reference Application Note M513 for reel size information.

Voltage Variable Absorptive Attenuator, 800 - 1000 MHz

Rev. V9

Electrical Specifications: $T_A = 25^\circ\text{C}$, $Z_0 = 50\Omega$

Parameter	Test Conditions	Frequency	Units	Min	Typ	Max
Insertion Loss	0 volts	800-1000 MHz	dB	—	3.5	4.2
		925 - 960 MHz	dB	—	3.3	3.9
Attenuation (Above Loss)	12 mA bias current	800-1000 MHz	dB	30	-	—
		925 - 960 MHz	dB	33	38	—
Attenuation Flatness	0 to 30 dB attenuation	800-1000 MHz	dB	—	1.5	2.5
		925 - 960 MHz	dB	—	0.4	0.8
VSWR	0 to 30 dB attenuation	800-1000 MHz	Ratio	—	1.6:1	2.0:1
		925 - 960 MHz	Ratio	—	1.4:1	1.7:1
Switching Speed	50% Control to 90%/10% RF	800-1000 MHz	μs	—	—	10.0
Linear Operation	—	800-1000 MHz	dBm	—	+20	—
Input IP_3	Two-tone inputs up to +10 dBm	800-1000 MHz	dBm	+35	+40	—
I_{Control}	—	800-1000 MHz	mA	—	—	30

Absolute Maximum Ratings ^{2,3}

Parameter	Absolute Maximum
Max. Input Power	+27 dBm
Operating Temperature	-40°C to +85°C
Storage Temperature	-65°C to +125°C

- Exceeding any one or combination of these limits may cause permanent damage to this device.
- M/A-COM does not recommend sustained operation near these survivability limits.

Handling Procedures

Please observe the following precautions to avoid damage:

Static Sensitivity

Gallium Arsenide Integrated Circuits are sensitive to electrostatic discharge (ESD) and can be damaged by static electricity. Proper ESD control techniques should be used when handling these devices.

Recommended PCB Configuration

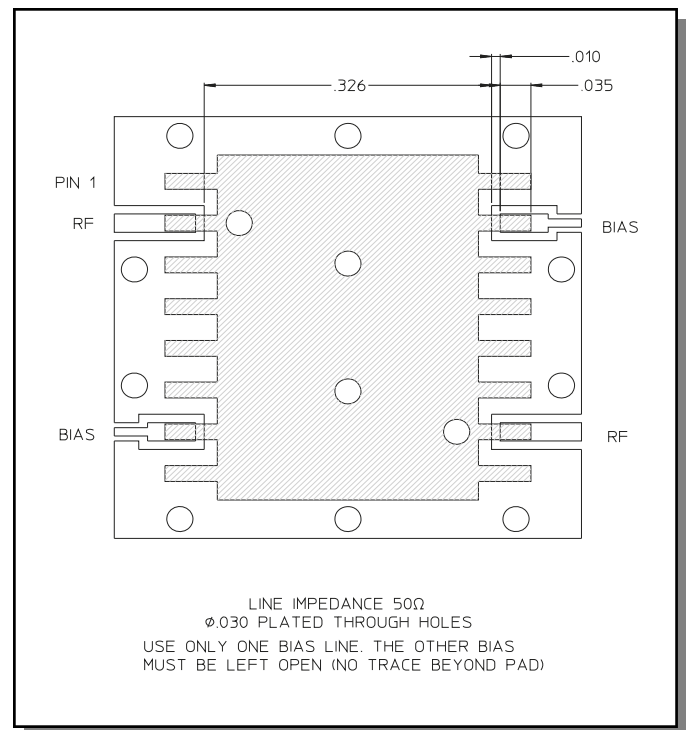

Typical Performance Curves

Insertion Loss

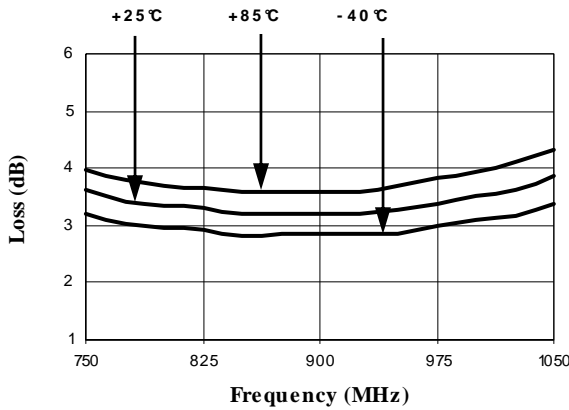

Attenuation Flatness (dB) @ +25°C

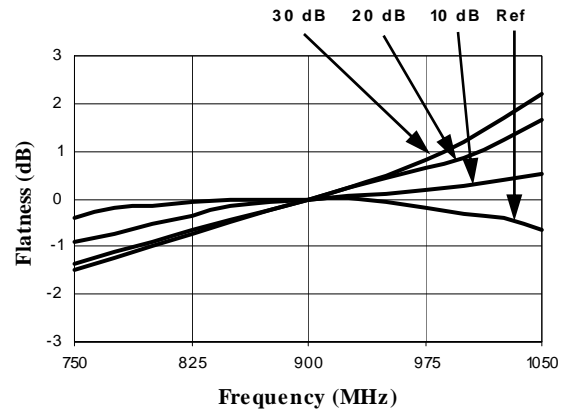

Typical VSWR @ +25°C

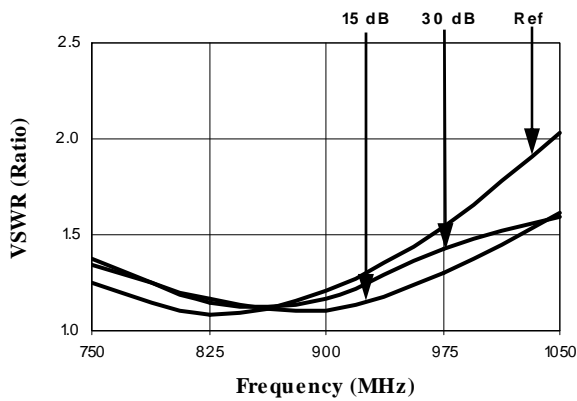

*Attenuation vs. Bias Current
Frequency = 1000 MHz*

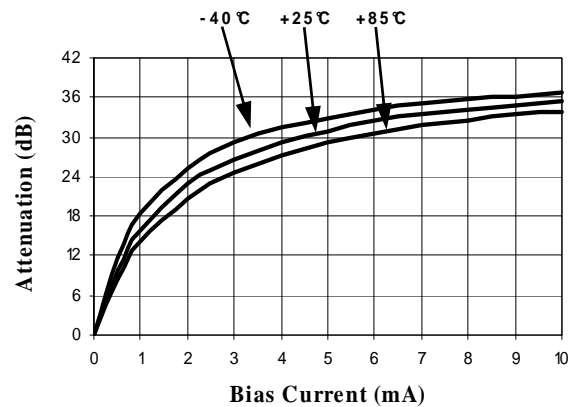

AT10-0009

Voltage Variable Absorptive Attenuator, 800 - 1000 MHz

Rev. V9

SOW-16[†]

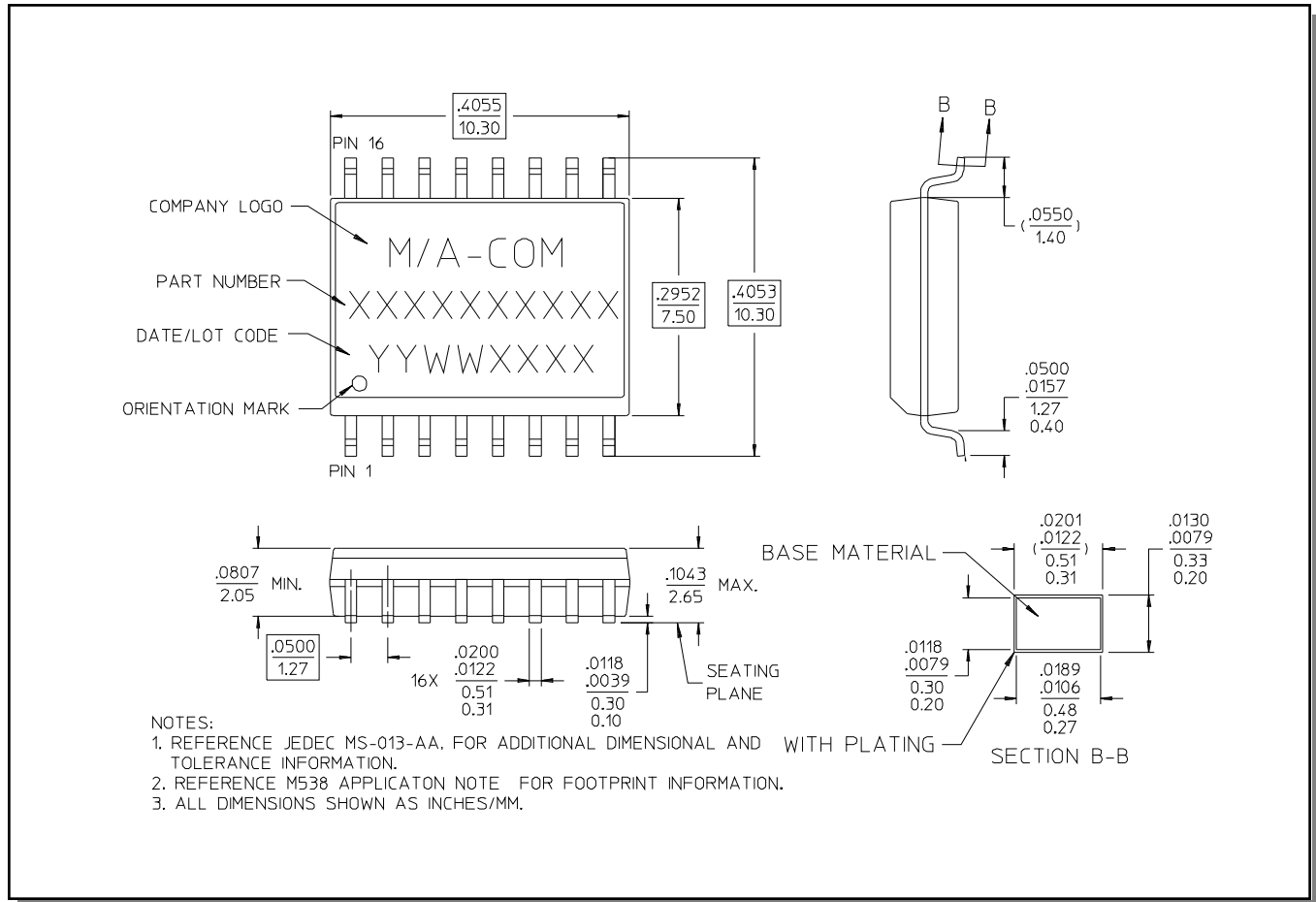

[†] Reference Application Note M538 for lead-free solder reflow recommendations.