

FEATURES

- ◆ Ultra Broad Bandwidth: 50 MHz to 40 GHz
- ◆ Functional Bandwidth : 50 MHz to 50 GHz
- ◆ Low Current consumption.
 - -10mA for low loss state
 - +10mA for Isolation state
- ◆ M/A-COM's unique AlGaAs hetero-junction anode technology.
- ◆ Silicon Nitride Passivation
- ◆ Polymer Scratch protection

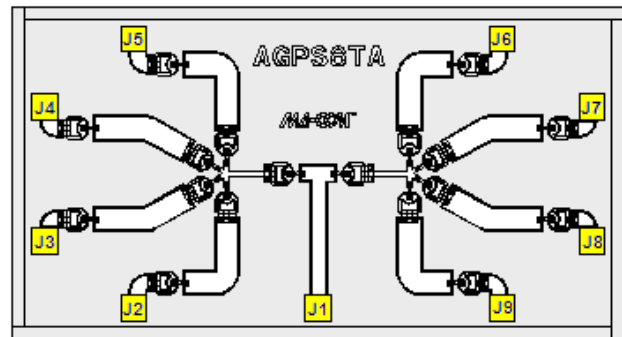

Yellow areas indicate bond pads

DESCRIPTION

M/A-COM's MA4AGSW8-1 is an Aluminum-Gallium-Arsenide, single pole, eight throw (SP8T), PIN diode switch. The switch features enhanced AlGaAs anodes which are formed using M/A-COM's patented hetero-junction technology. AlGaAs technology produces a switch with less loss than a device fabricated using conventional GaAs processes. As much as a 0.3 dB reduction in insertion loss can be realized at 50 GHz. This device is fabricated on an OMCVD epitaxial wafer using a process designed for high device uniformity and extremely low parasitics. The diodes within the chip exhibit low series resistance, low capacitance, and fast switching speed. They are fully passivated with silicon nitride and have an additional polymer layer for scratch protection. The protective coating prevents damage during handling and assembly to the diode junction and the chip anode air-bridges. Off chip bias circuitry is required.

APPLICATIONS

The high electron mobility of AlGaAs and the low capacitance of the PIN diodes used makes this switch ideal for fast response, high frequency, multi-throw switch designs. AlGaAs PIN diode switches are an ideal choice for switching arrays in radar systems, radiometers, test equipment and other multi-assembly components.

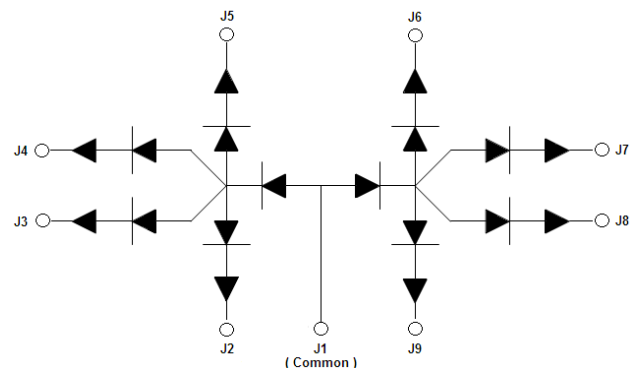

Absolute Maximum Ratings @ T_{AMB} = +25°C

Parameter	Maximum Rating
Operating Temperature	-55°C to +125°C
Storage Temperature	-55°C to +150°C
Incident C.W. RF Power	+23dBm C.W.
Breakdown Voltage	25V
Bias Current	± 25mA
Assembly Temperature	+300°C < 10 sec
Junction Temperature	+175°C

Maximum combined operating conditions for RF Power, D.C. bias, and temperature: +23 dBm C.W. @ 10 mA (per diode) @ +85°C.

**Electrical Specifications @ T_A = 25°C, +/-15mA bias current and 0V
(On-wafer measurements)**

RF SPECIFICATIONS					
PARAMETER	FREQUENCY BAND	MIN	TYP	MAX	UNITS
INSERTION LOSS	0.05 - 18 GHz	-	1.5	2.0	dB
	18 - 26 GHz	-	1.8	2.1	dB
	26 - 40 GHz	-	2.0	2.3	dB
ISOLATION ¹	0.05 - 18 GHz	30	32	-	dB
	18 - 26 GHz	30	32	-	dB
	26 - 40 GHz	30	32	-	dB
INPUT/OUTPUT RETURN LOSS	0.05 - 18 GHz	10	15	-	dB
	18 - 26 GHz	13	15	-	dB
	26 - 40 GHz	10	20	-	dB

***Note:** Isolation is measured through (3) diodes from common port (input) to selected output port with (1) opposite series junction diode in low loss. Isolation for (2) diodes from common port (Input) to selected output with the same series junction diode port in low loss = 22 dB Typical.

Parameter	F (GHz)	Test Conditions	Typical Value	Units
Switching Speed* (10-90 % RF Voltage)	10.0	+/- 5V TTL Compatible PIN Diode Driver	20	nS

***Note:** Typical switching speed is measured from 10% to 90% of the detected RF voltage driven by a +/- 5V TTL compatible driver. Driver output parallel RC network uses a capacitor between 390 pF-560 pF and a resistor between 150-220 Ω ohms to achieve 15 ns rise and fall times.

Typical R.F. Performance (Probed on Wafer) @ +25°C

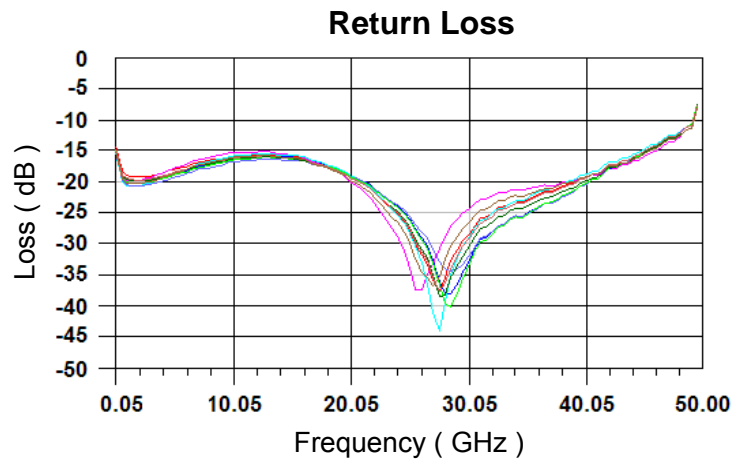
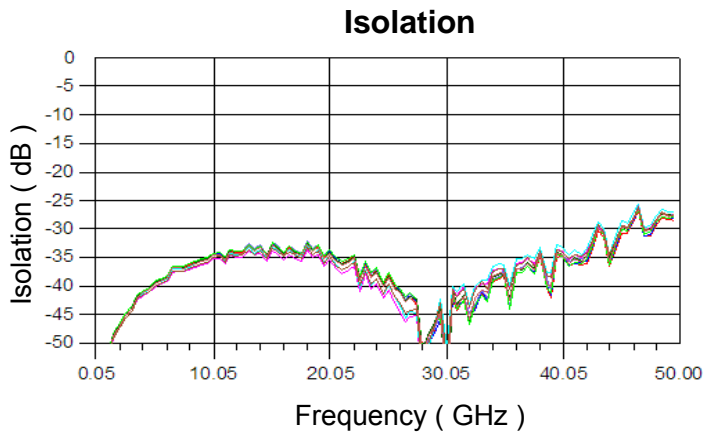
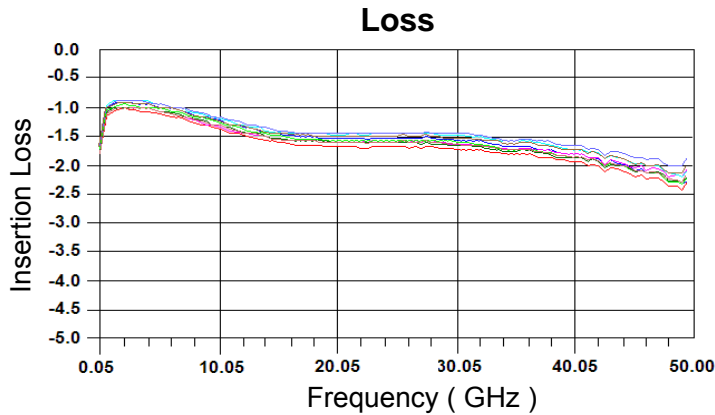

Operation of the MA4AGSW8-1 Switch

The application of either a +15 mA or -15 mA DC bias current to the selected output port will provide the low insertion loss state. Typically this low loss, “ON” bias voltage through (3) series diodes is 4.5 Volts maximum. All isolated ports are set to 0V at 0 mA, or, to improve switching speed and isolation, a back bias of 5V/0 mA may also be applied. RF to DC bias networks are required on all RF ports. To switch the individual RF ports on and off, a simple single +5V, PIN diode supply, with a TTL gate driver can be used to supply current for the low loss state or 0 V back bias for isolation . In this bias scheme, +5V through a current limiting resistor would be applied at the common port, J1 and each RF port would be connected to a TTL gate. Low loss would occur when the selected gate voltage, TTL0, at the output port is 5V/+15 mA and isolation would occur when the selected gate voltage, TTL1, is -5V/0mA. For faster switching speeds, < 20 nS, a ± 5V ,PIN diode TTL driver should be employed to help remove the diode stored charge with back bias.

MA4AGSW8-1 Schematic and Driver Bias Connections

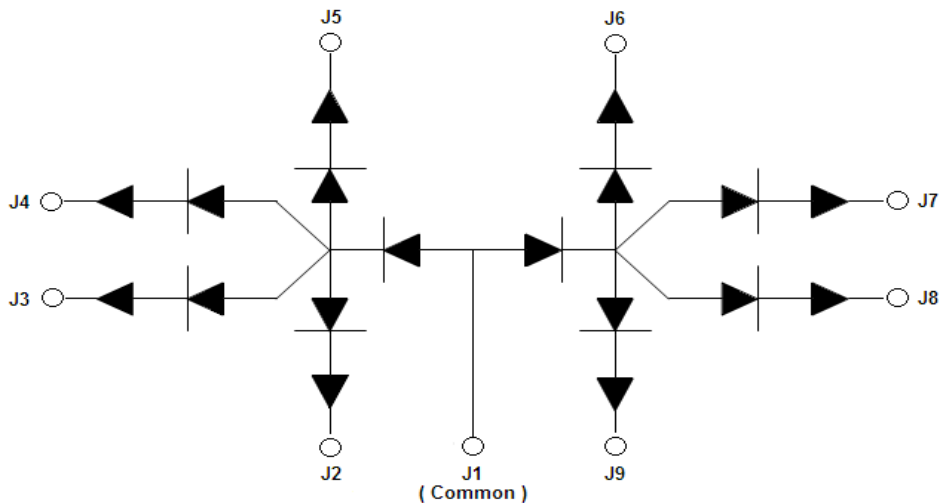

TYPICAL DRIVER CONNECTIONS

Input Port	Output Ports							
	-15mA @ J2	-15mA @ J3	-15mA @ J4	-15mA @ J5	-15 mA @ J6	-15mA @ J7	-15mA @ J8	-15mA @ J9
J1	Low Loss	Isolation	Isolation	Isolation	Isolation	Isolation	Isolation	Isolation
J1	Isolation	Low Loss	Isolation	Isolation	Isolation	Isolation	Isolation	Isolation
J1	Isolation	Isolation	Low Loss	Isolation	Isolation	Isolation	Isolation	Isolation
J1	Isolation	Isolation	Isolation	Low Loss	Isolation	Isolation	Isolation	Isolation
J1	Isolation	Isolation	Isolation	Isolation	Low Loss	Isolation	Isolation	Isolation
J1	Isolation	Isolation	Isolation	Isolation	Isolation	Low Loss	Isolation	Isolation
J1	Isolation	Isolation	Isolation	Isolation	Isolation	Isolation	Low Loss	Isolation
J1	Isolation	Isolation	Isolation	Isolation	Isolation	Isolation	Isolation	Low Loss

Notes:
Low Loss = -15mA applied at the specified Output Port. (A dc ground return at port J1 must be provided)
Isolation = 0 Volts applied at the specified Output Ports.

Chip Dimensions and Bonding Pad Locations (In Yellow)

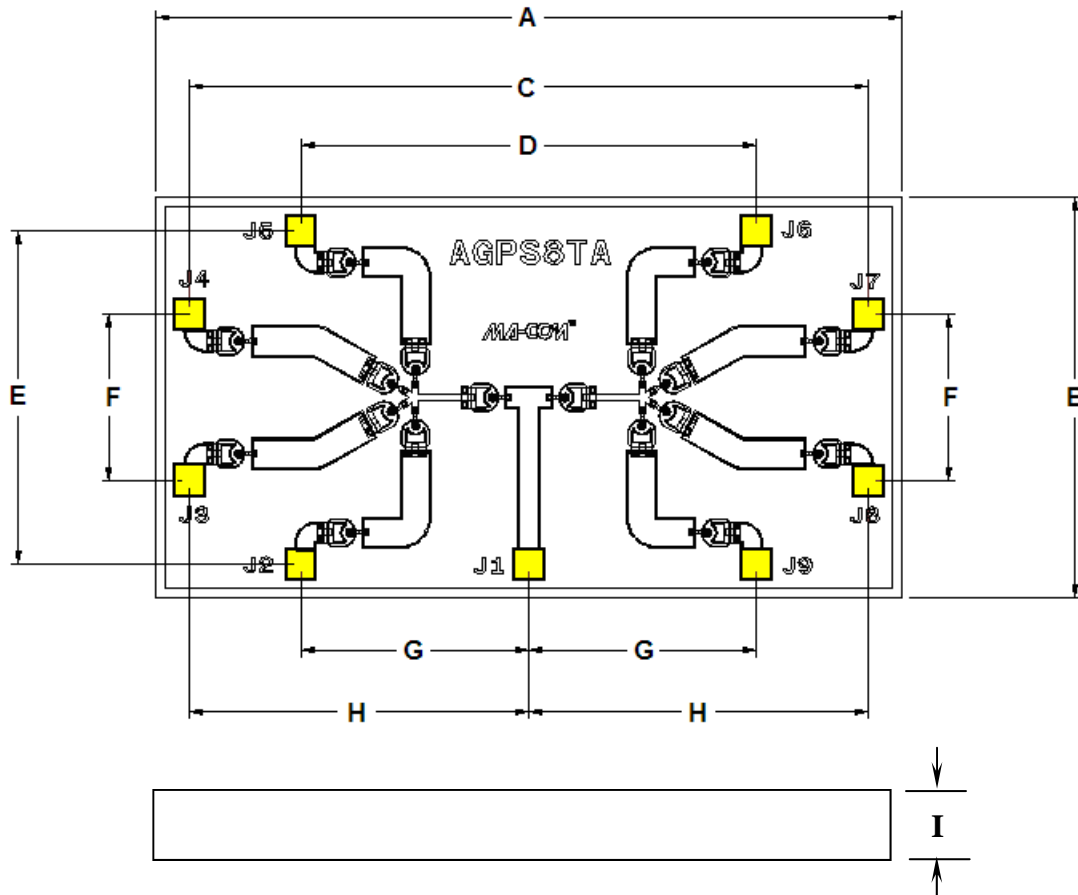

Dimension	mils		mm	
	min	max	min	max
A	92.7	93.9	2.355	2.385
B	49.4	50.6	1.255	1.285
C	84.8	85.2	2.153	2.163
D	56.9	57.3	1.445	1.455
E	41.5	41.9	1.055	1.065
F	20.6	21.0	0.523	0.533
G	28.3	28.7	0.720	0.730
H	42.3	42.7	1.074	1.084
I	3.7	4.2	0.094	0.107
Bond Pads	3.7	4.2	0.094	0.107

ASSEMBLY INSTRUCTIONS

CLEANLINESS

The chip should be handled in a clean environment.

STATIC SENSITIVITY

This device is considered ESD Class 1A, HBM. Proper ESD techniques should be used during handling.

GENERAL HANDLING

The protective polymer coating on the active areas of the die provides scratch and impact protection, particularly for the metal air bridge, which contacts the diode's anode. Die should primarily be handled with vacuum pickup tools, or alternatively with plastic tweezers.

ASSEMBLY TECHNIQUES

The MA4AGSW8-1, AlGaAs switch is designed to be mounted with electrically conductive silver epoxy or with a low temperature solder perform, which does not have a rich tin content.

SOLDER DIE ATTACH

Only solders which do not scavenge gold, such as 80Au/20Sn or Indalloy #2 is recommended. Do not expose die to temperatures greater than 300°C for more than 10 seconds.

CONDUCTIVE EPOXY DIE ATTACH

Use a controlled thickness of approximately 2 mils for best electrical conductivity and lowest thermal resistance. Cure epoxy per manufacturer's schedule. Typically 150°C for 1 hour.

RIBBON/WIRE BONDING

Thermo-compression wedge or ball bonding may be used to attach ribbons or wire to the gold bonding pads. A 1/4 x 3 mil gold ribbon is recommended on all RF ports and should be kept as short as possible for the lowest inductance and best microwave performance. For more detailed handling and assembly instructions, see [Application Note M541](#), "Bonding and Handling Procedures for Chip Diode Devices" at www.macom.com.

Ordering Information

Part Number	Packaging
MA4AGSW8-1	Waffle Pack