

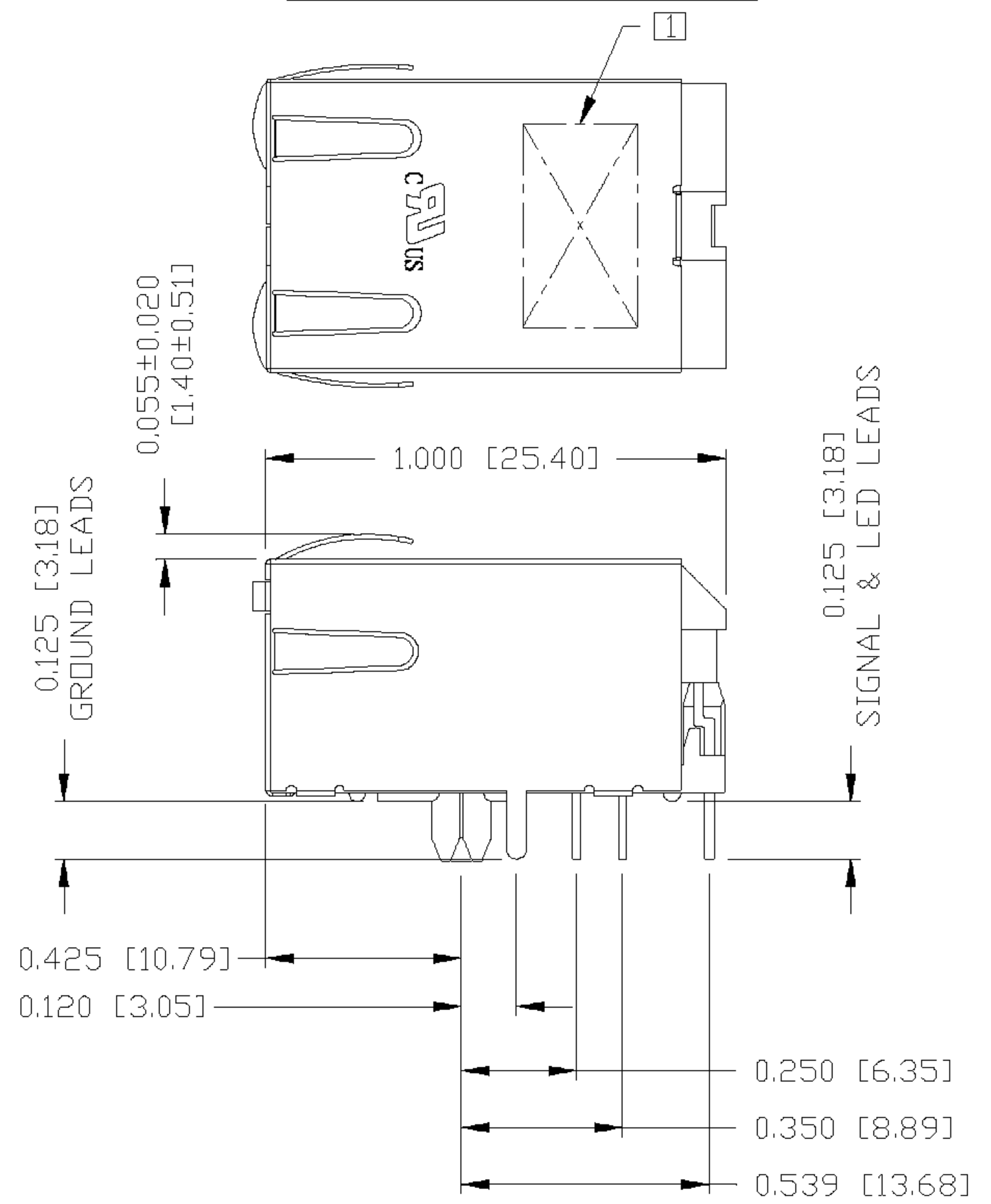

THE INFORMATION CONTAINED HEREIN IS CONSIDERED "PROPRIETARY" TO BEL FUSE INC. AND SHALL NOT BE COPIED, REPRODUCED OR DISCLOSED WITHOUT THE WRITTEN APPROVAL OF BEL FUSE INC.

MECHANICAL SPECIFICATION

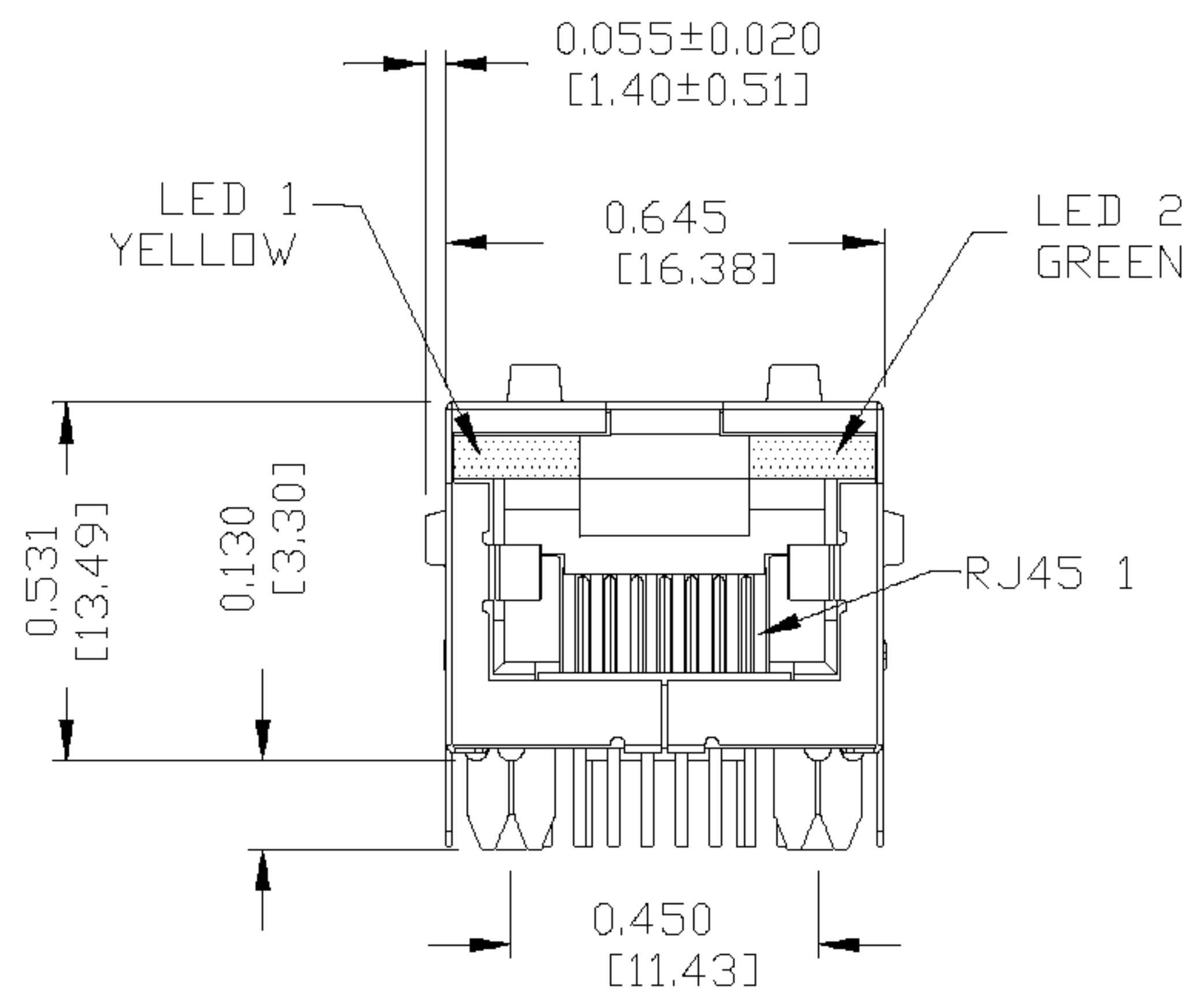

NOTES:  
 PLASTIC HOUSING: THERMOPLASTIC PBT  
 FLAMMABILITY RATING UL 94V-0  
 CONTACT PLATING: 50 MICRO-INCH HARD GOLD PLATING  
 PINS: TIN-COATED COPPER WIRE, DIA 0.018 INCH.  
 METAL SHIELD: NICKEL LEAD PLATED ON COPPER ALLOY.  
 (ALL GROUND LEAD ARE SOLDER DIPPED)

[1] MARK PART WITH MFG LOGO, MFG NAME, PART NUMBER, AND DATE CODE.

**UL** US UL RECOGNIZED - FILE #E196366 AND E169987.  
 JACK CAVITY CONFORMS TO FCC RULES AND REGULATIONS.

ORIGINATED BY	DATE	TITLE	PART NO. / DRAWING NO.	STANDARD DIM. TOL. IN INCH	[ ] METRIC DIM. AS REFERENCE	<p>COMPONENTS FOR A CONNECTED PLANET</p>
CHRIS/BILL	03-03-07	staggered pin MagJack® (5 cores)	0817-1A1T-11	.X	UNIT : INCH [mm]	
DRAWN BY	DATE		FILE NAME	.XX	SCALE : N/A	
JOLLY	03-03-07	08171A1T11I.DWG	.XXX	±0.010	REV. : I SIZE : A4 PAGE : 3	

THE INFORMATION CONTAINED HEREIN IS CONSIDERED "PROPRIETARY" TO BEL FUSE INC. AND SHALL NOT BE COPIED, REPRODUCED OR DISCLOSED WITHOUT THE WRITTEN APPROVAL OF BEL FUSE INC.

RECOMMENDED PCB FOOTPRINT

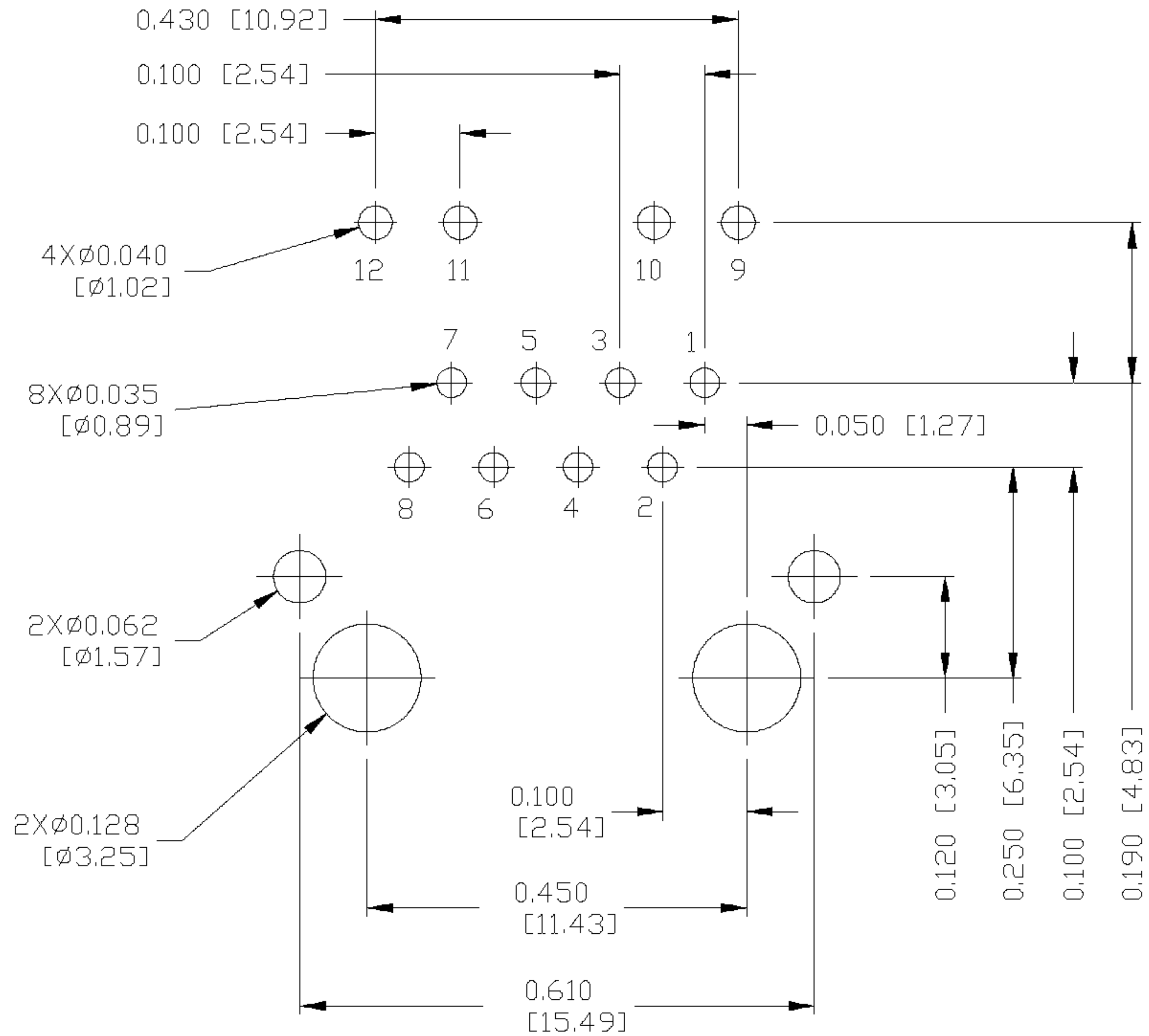

ORIGINATED BY	DATE	TITLE	PART NO. / DRAWING NO.	STANDARD DIM.	[ ] METRIC DIM. AS REFERENCE	
CHRIS/BILL	03-03-07	staggered pin MagJack® (5 cores)	0817-1A1T-11	TOL. IN INCH	UNIT : INCH [mm]	REV. : 1
DRAWN BY	DATE		FILE NAME	.X	SCALE : N/A	SIZE : A4
JOLLY	03-03-07	08171A1T11I.DWG	.XX	.XXX ±0.004	PAGE : 4	



THE INFORMATION CONTAINED HEREIN IS CONSIDERED "PROPRIETARY" TO BEL FUSE INC. AND SHALL NOT BE COPIED, REPRODUCED OR DISCLOSED WITHOUT THE WRITTEN APPROVAL OF BEL FUSE INC.

SUGGESTED PANEL OPENING

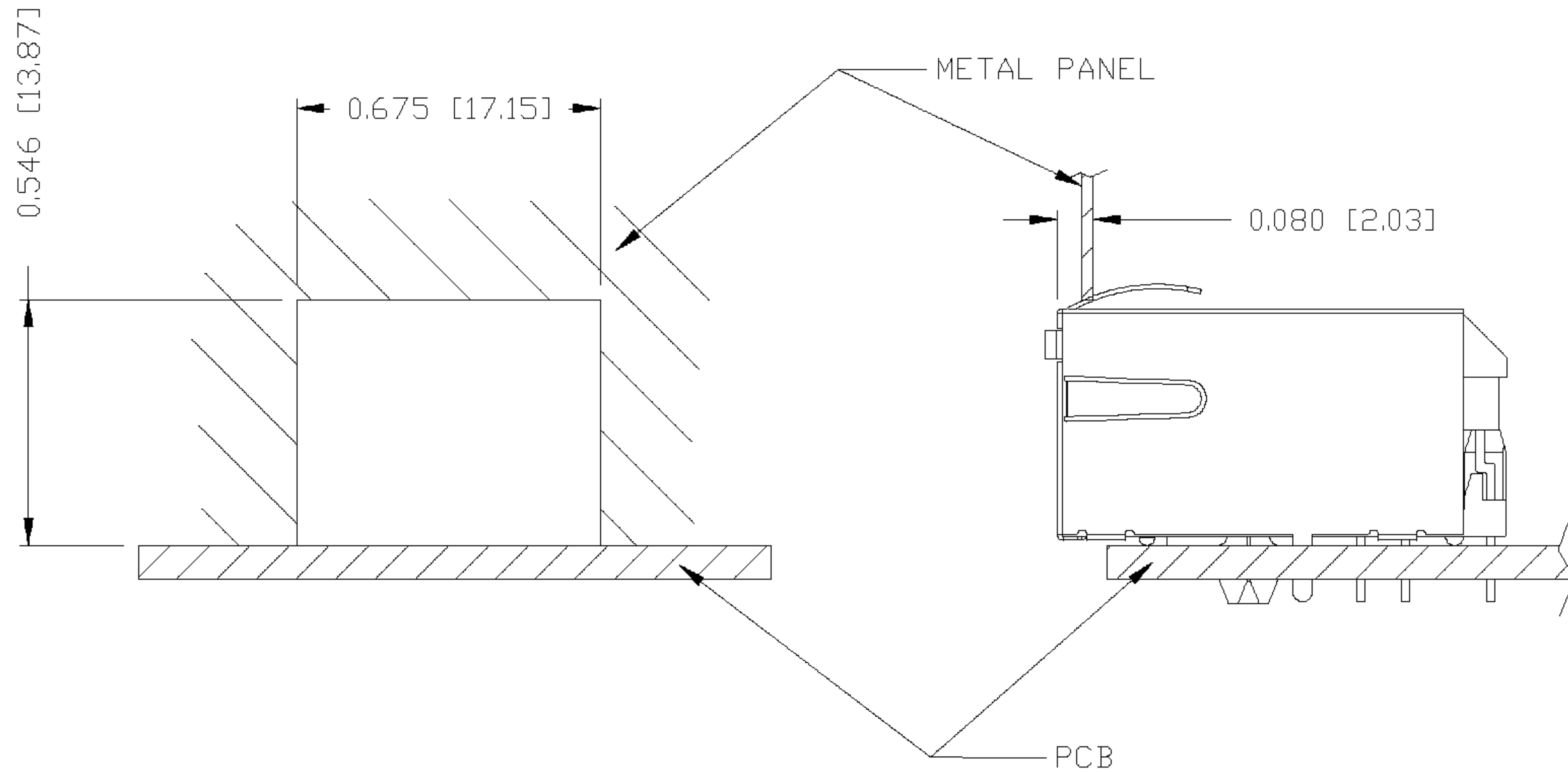

NOTE :

THE DISTANCE OF PANEL INSIDE SURFACE RELATIVE TO FRONT SURFACE OF PART IS ONLY A SUGGESTION. IN CASE THIS DISTANCE IS DIFFERENT, THE REQUIRED PANEL OPENING DIMENSIONS CHANGE ACCORDINGLY.



PACKING INFORMATION

PACKING TRAY : 0200-9999-A2

PACKING QUANTITY : 60 PCS FINISHED GOODS PER TRAY

11 TRAYS (660 PCS FINISHED GOODS) PER CARTON BOX

NOTE : CARDBOARDS ARE PLACED BETWEEN LAYERS OF PACKING TRAY INSIDE CARTON BOX (INCLUDE THE UPPERMOST AND LOWERMOST TRAY)

ORIGINATED BY CHRIS/BILL	DATE 03-03-07	TITLE staggered pin MagJack® (5 cores)	PART NO. / DRAWING NO. 0817-1A1T-11		STANDARD DIM. TOL. IN INCH		[ ] METRIC DIM. AS REFERENCE		 COMPONENTS FOR A CONNECTED PLANET
			FILE NAME 08171A1T11I.DWG		.X		UNIT : INCH [mm]	REV. : I	
DRAWN BY JOLLY	DATE 03-03-07				.XX		SCALE : N/A	SIZE : A4	
					.XXX	±0.004		PAGE : 5	