



SCHEMATIC

ELECTRICAL CHARACTERISTICS @ 25°C

URNS RATIO

TP1	1CT : 1CT ±2%
TP2	1CT : 1CT ±2%
TP3	1CT : 1CT ±2%
TP4	1CT : 1CT ±2%

CL @ 100kHz/100mVRMS

8mA DC BIAS	350µH MIN.
-------------	------------

INS. LOSS

0.1MHz TO 1MHz	-1.1 dB MAX
1MHz TO 65MHz	-0.5 dB MAX
65MHz TO 100MHz	-0.8 dB MAX
100MHz TO 125MHz	-1.2 dB MAX

RET. LOSS (MIN)

0.5MHz-40MHz	-18 dB
40MHz-100MHz	-12+20LOG(f/80MHz) dB

CM TO CM REJ

100kHz - 100MHz	-30 dB MIN
-----------------	------------

CM TO DM REJ

100kHz - 100MHz	-35 dB MIN
-----------------	------------

HIPOT (Isolation Voltage):

1500 Vrms

100% OF PRODUCTION TESTED TO COMPLY
WITH IEEE 802.3 ISOLATION REQUIREMENTS.

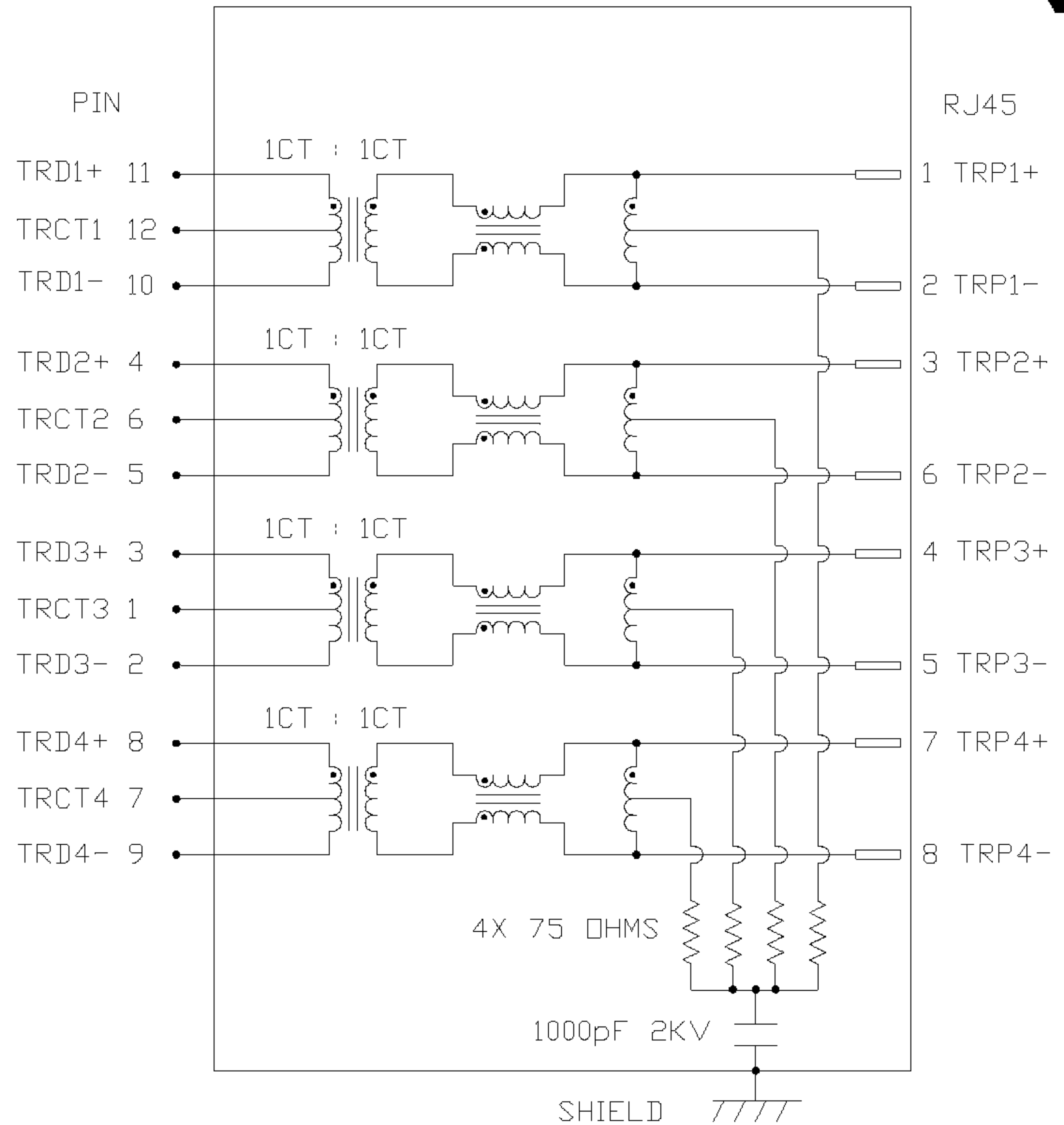

ORIGINATED BY CHOW WANG CHUNG	DATE 05-16-07	TITLE gigabit MagJack® (12 Cores, Tab Up, Without LED)	PART NO. / DRAWING NO. 08161X4T23-F	STANDARD DIM. TOL. IN INCH .X .XX .XXX	[] METRIC DIM. AS REFERENCE UNIT : INCH [mm] SCALE : N/A REV. : A SIZE : A4 PAGE : 2	<p>COMPONENTS FOR A CONNECTED PLANET</p>
DRAWN BY LEE WEI DE	DATE 05-16-07	FILE NAME 08161X4T23-F_A.DWG				

THE INFORMATION CONTAINED HEREIN IS CONSIDERED "PROPRIETARY" TO BEL FUSE INC. AND SHALL NOT BE COPIED, REPRODUCED OR DISCLOSED WITHOUT THE WRITTEN APPROVAL OF BEL FUSE INC.

RoHS
2002/95/EC



NOTES:

PLASTIC HOUSING: THERMOPLASTIC PBT
FLAMMABILITY RATING UL 94V-0
CONTACTS PLATING: 50 MICRO-INCH HARD GOLD PLATING
PINS: TIN-COATED COPPER WIRE, DIA 0.018 INCH.
METAL SHIELD: NICKEL PLATED ON COPPER ALLOY.
(ALL GROUND LEADS ARE SOLDER DIPPED)

[1] MARK PART WITH MFG LOGO, MFG NAME, PART NUMBER AND DATE CODE.

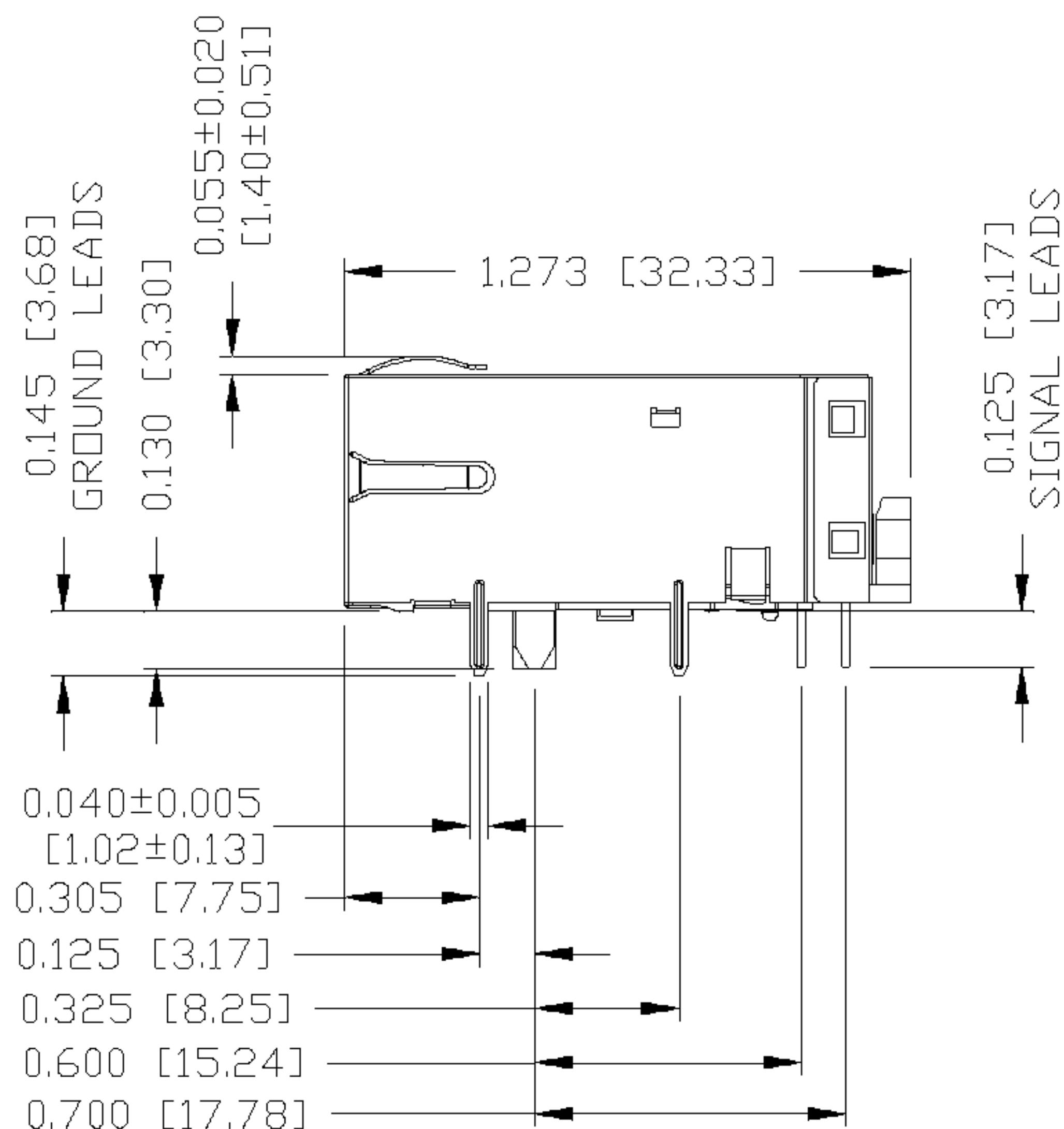
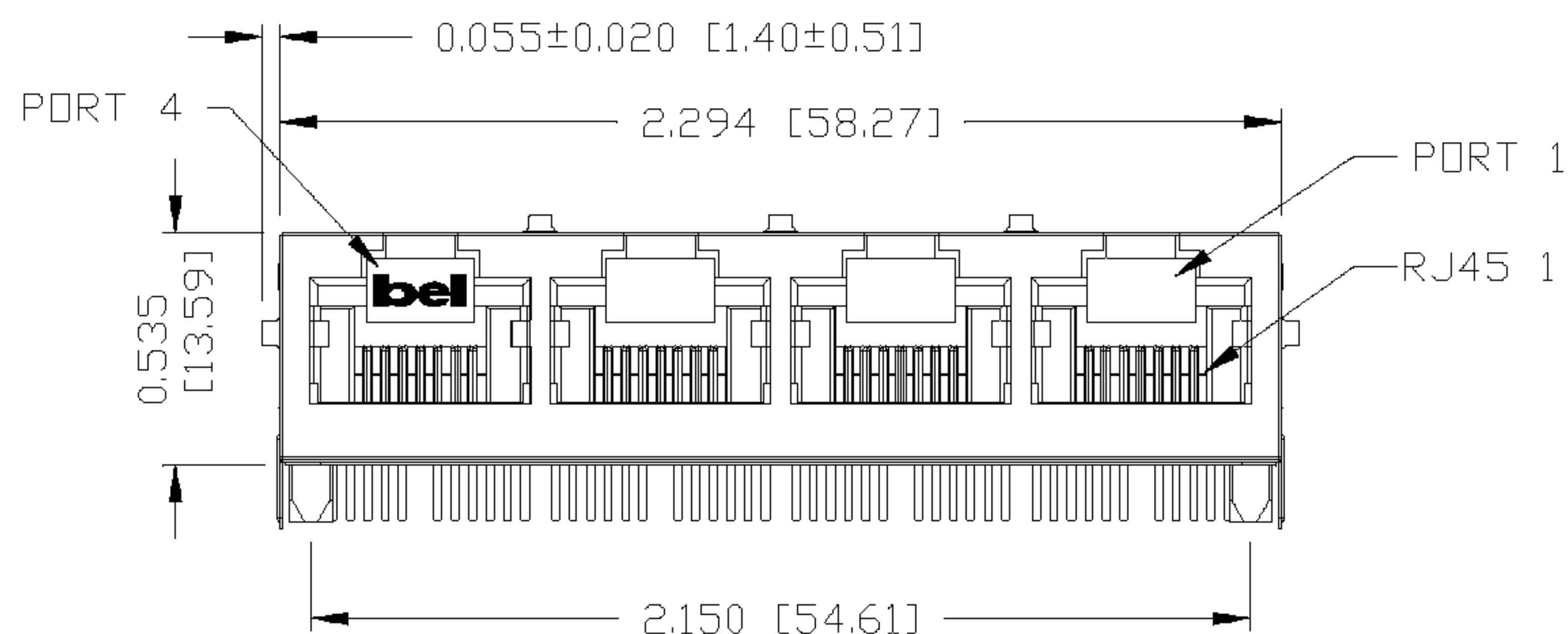
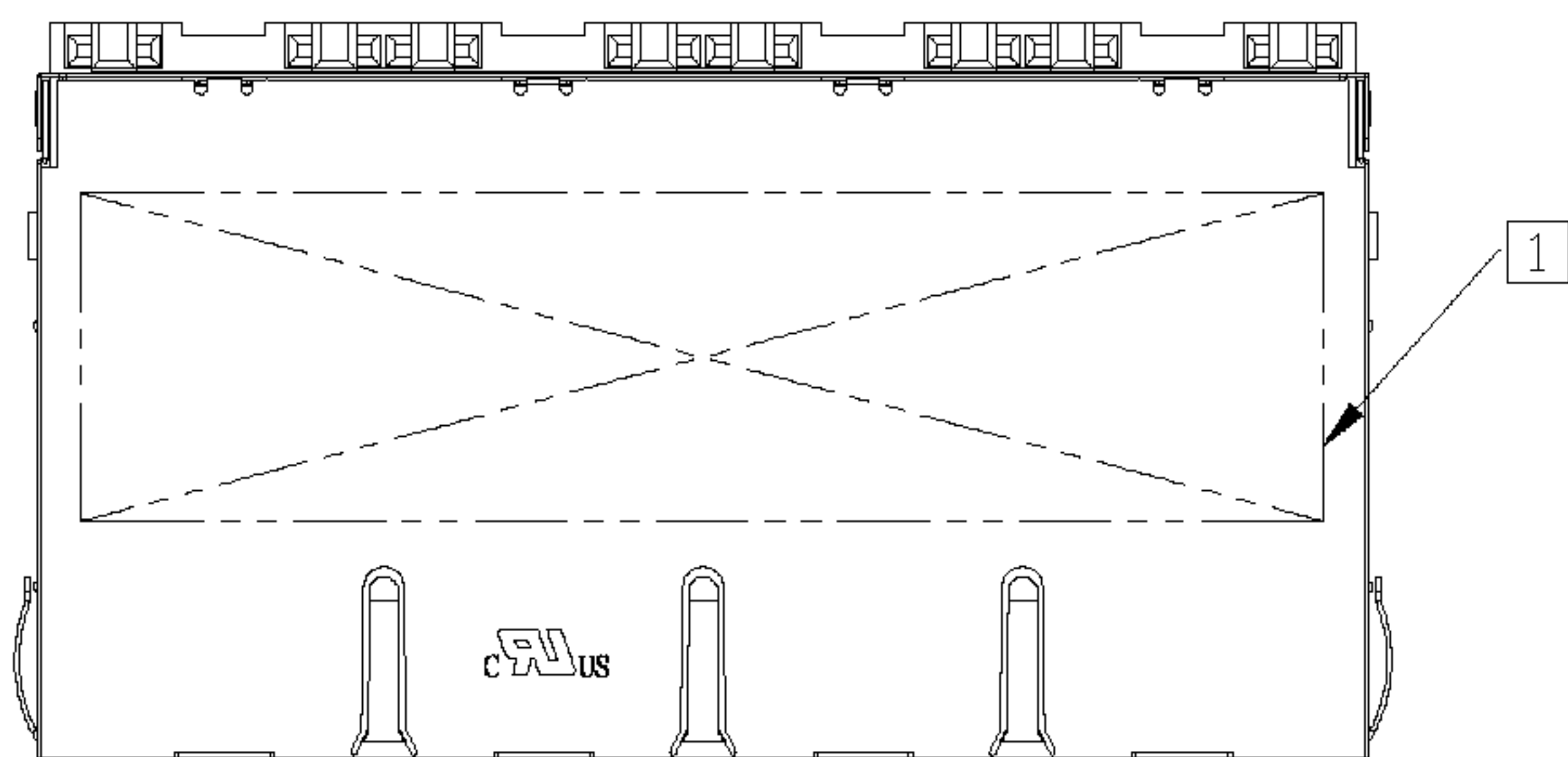

bel US UL RECOGNIZED - FILE #E196366 AND E169987.
RoHS COMPLIANCE, PER EU DIRECTIVE 2002/95/EC
JACK CAVITY CONFORMS TO FCC RULES AND REGULATIONS.

ORIGINATED BY LIU QIN	DATE 05-16-07	TITLE gigabit MagJack® (12 Cores, Tab Up, Without LED)	PART NO. / DRAWING NO. 08161X4T23-F	STANDARD DIM. TOL. IN INCH	[] METRIC DIM. AS REFERENCE
DRAWN BY CHEN TING	DATE 05-16-07	0816-1X4T-23-F	FILE NAME 08161X4T23-F_A.DWG	.X .XX .XXX ±0.010	UNIT : INCH [mm] SCALE : N/A REV. : A SIZE : A4 PAGE : 3



THE INFORMATION CONTAINED HEREIN IS CONSIDERED "PROPRIETARY" TO BEL FUSE INC. AND SHALL NOT BE COPIED, REPRODUCED OR DISCLOSED WITHOUT THE WRITTEN APPROVAL OF BEL FUSE INC.

RoHS
2002/95/EC

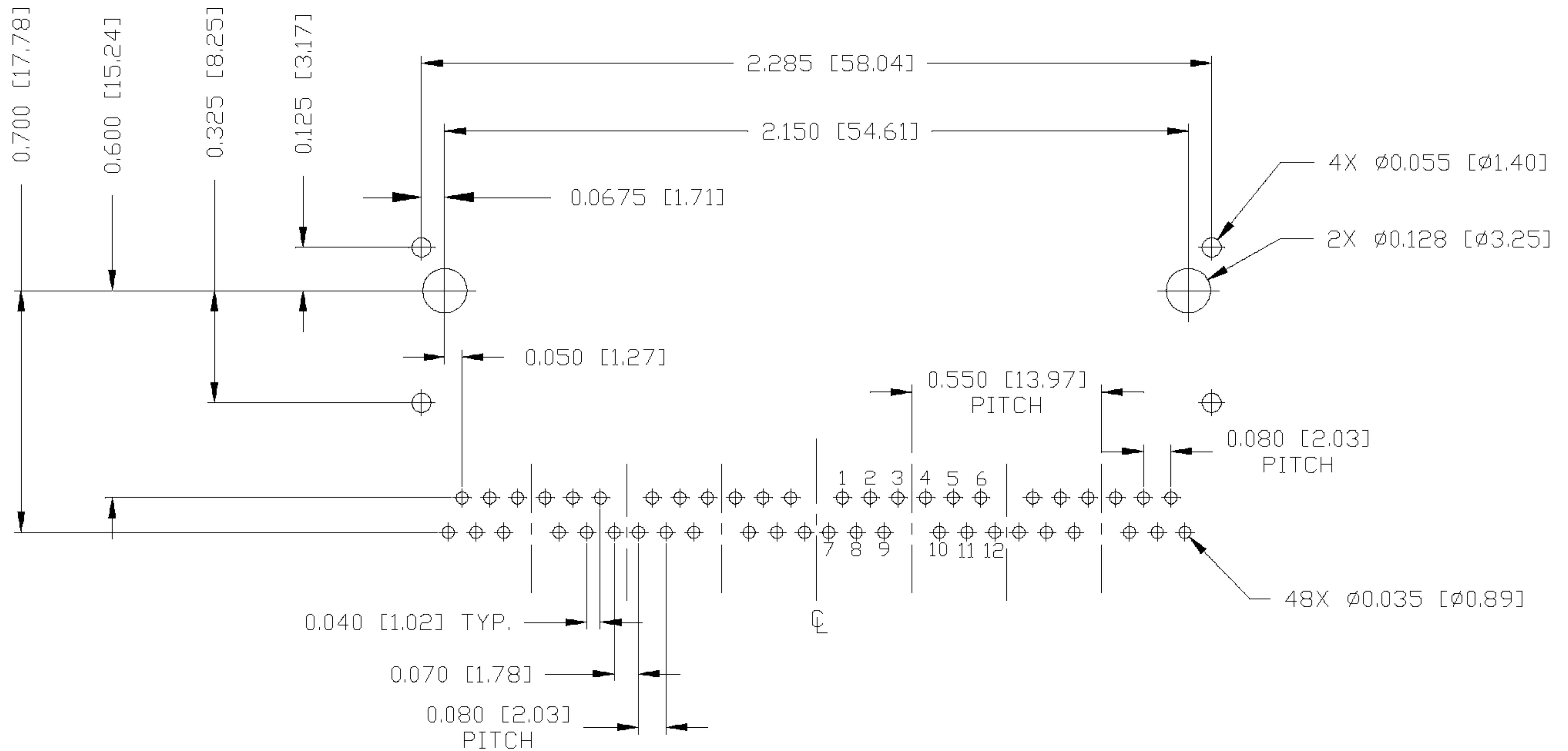

RECOMMENDED PCB FOOTPRINT
COMPONENT SIDE VIEW

ORIGINATED BY LIU QIN	DATE 05-16-07	TITLE gigabit MagJack® (12 Cores, Tab Up, Without LED)	PART NO. / DRAWING NO. 08161X4T23-F	STANDARD DIM. TOL. IN INCH		[] METRIC DIM. AS REFERENCE		 COMPONENTS FOR A CONNECTED PLANET
				.X		UNIT : INCH [mm]	REV. : A	
DRAWN BY CHEN TING	DATE 05-16-07	FILE NAME 08161X4T23-F_A.DWG	.XX		SCALE : N/A	SIZE : A4		
			.XXX	±0.004		PAGE : 4		



THE INFORMATION CONTAINED HEREIN IS CONSIDERED "PROPRIETARY" TO BEL FUSE INC. AND SHALL NOT BE COPIED, REPRODUCED OR DISCLOSED WITHOUT THE WRITTEN APPROVAL OF BEL FUSE INC.

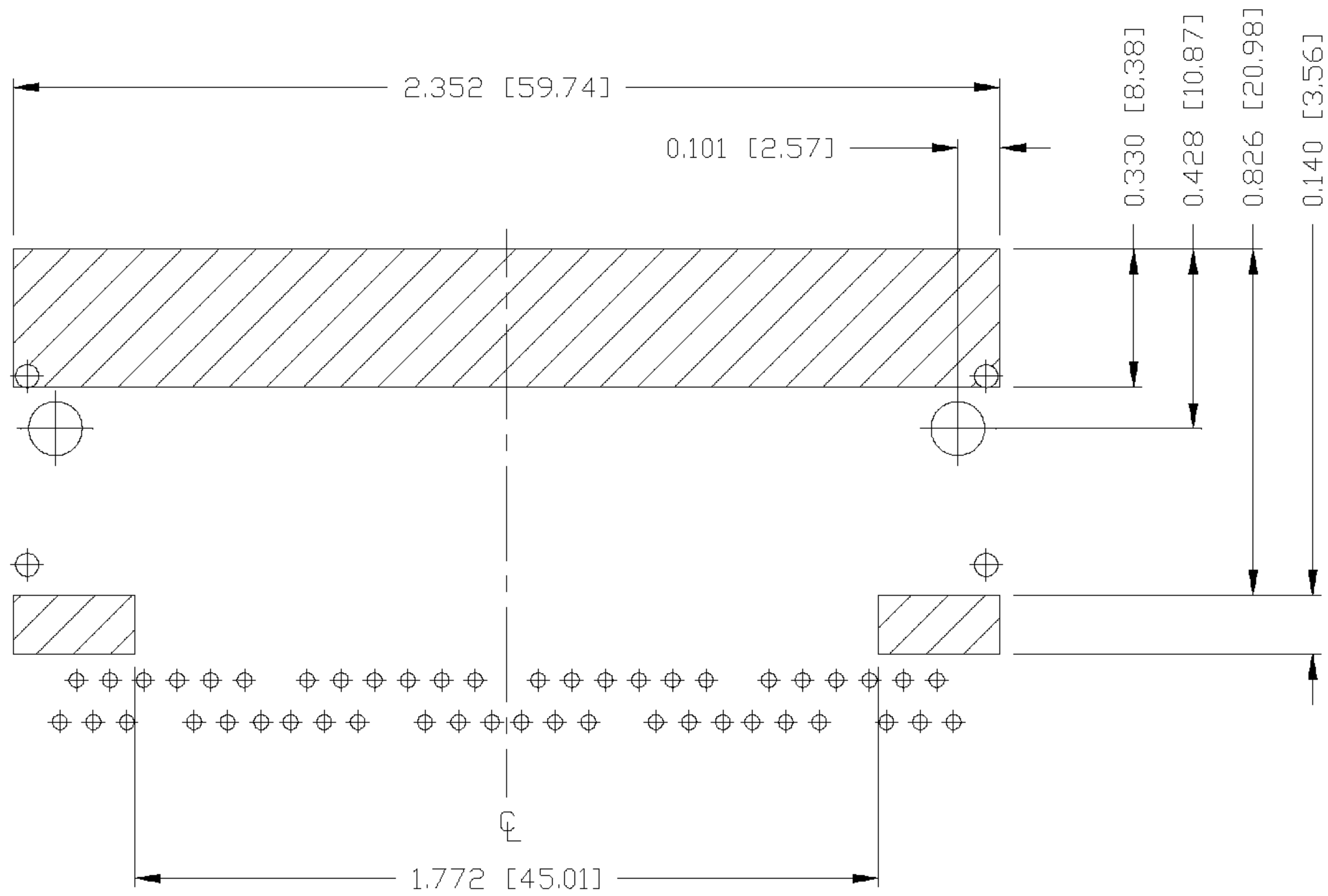

NOTES

THE SHADED AREA ON THE CUSTOMER BOARD ARE RECOMMENDED TO BE CLEAR OFF ANY VIA HOLE OR COMPONENT PAD.

ORIGINATED BY LIU QIN	DATE 05-16-07	TITLE gigabit MagJack® (12 Cores, Tab Up, Without LED)	PART NO. / DRAWING NO. 08161X4T23-F	STANDARD DIM. TOL. IN INCH		[] METRIC DIM. AS REFERENCE		REV. : A	SIZE : A4	PAGE : 5
				.X		UNIT : INCH [mm]	SCALE : N/A			
DRAWN BY CHEN TING	DATE 05-16-07	FILE NAME 08161X4T23-F_A.DWG		.XX						
				.XXX	±0.004					



THE INFORMATION CONTAINED HEREIN IS CONSIDERED "PROPRIETARY" TO BEL FUSE INC. AND SHALL NOT BE COPIED, REPRODUCED OR DISCLOSED WITHOUT THE WRITTEN APPROVAL OF BEL FUSE INC.



SUGGESTED PANEL OPENING

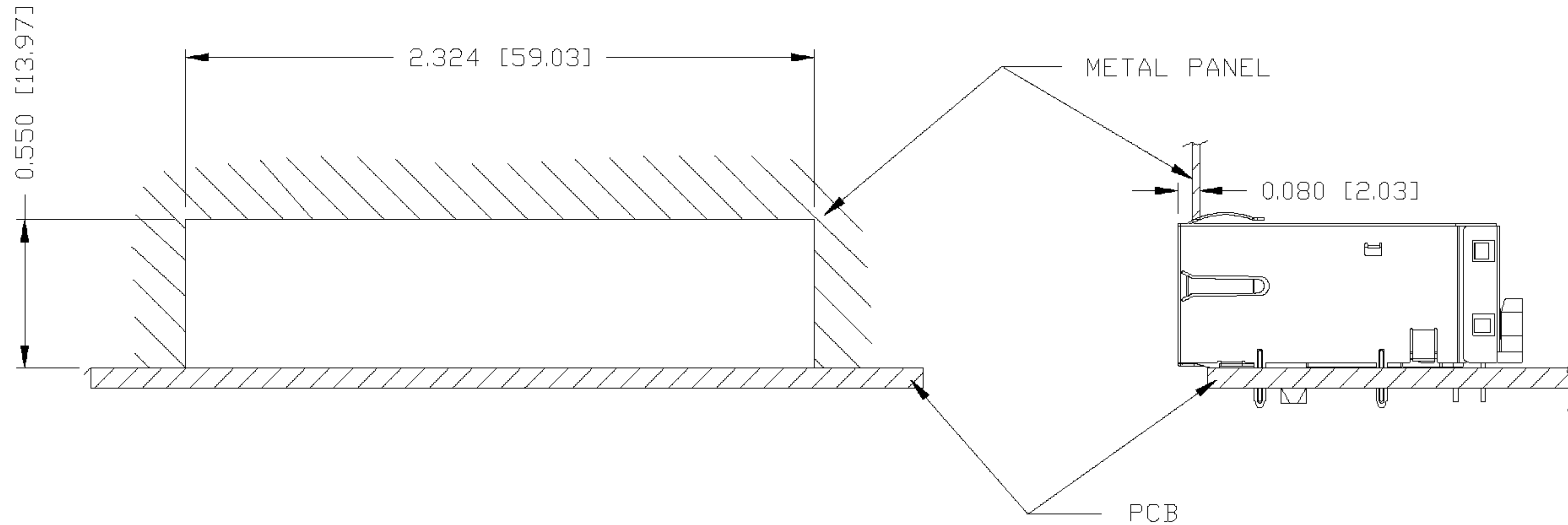

NOTES:

THE DISTANCE OF PANEL INSIDE SURFACE RELATIVE TO FRONT SURFACE OF PART IS ONLY A SUGGESTION. IN CASE THIS DISTANCE IS DIFFERENT, THE REQUIRED PANEL OPENING DIMENSIONS CHANGE ACCORDINGLY.

PACKING INFORMATION

PACKING TRAY : 0200-9999-B4 (TOP)
0200-9999-B5 (BOTTOM)

PACKING QUANTITY : 24 PCS FINISHED GOOD PER TRAY
10 TRAYS (240 PCS FINISHED GOODS) PER CARTON BOX

NOTE : CARDBOARDS ARE PLACED BETWEEN LAYERS OF PACKING TRAY INSIDE CARTON BOX
(INCLUDE THE UPPERMOST AND LOWERMOST TRAY)

ORIGINATED BY LIU QIN	DATE 05-16-07	TITLE gigabit MagJack® (12 Cores, Tab Up, Without LED) 0816-1X4T-23-F	PART NO. / DRAWING NO. 08161X4T23-F	STANDARD DIM.		[] METRIC DIM. AS REFERENCE		 COMPONENTS FOR A CONNECTED PLANET
				TOL. IN INCH		UNIT : INCH [mm]	REV. : A	
DRAWN BY CHEN TING	DATE 05-16-07	FILE NAME 08161X4T23-F_A.DWG	.X		SCALE : N/A	SIZE : A4		
			.XX			PAGE : 6		
				.XXX ±0.004				