

DC - 20 GHz Discrete power pHEMT

TGF2022-48

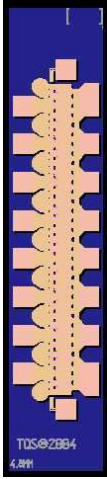

Product Description

The TriQuint TGF2022-48 is a discrete 4.8 mm pHEMT which operates from DC-20 GHz. The TGF2022-48 is designed using TriQuint's proven standard 0.35um power pHEMT production process.

The TGF2022-48 typically provides > 37 dBm of saturated output power with power gain of 13 dB. The maximum power added efficiency is 58% which makes the TGF2022-48 appropriate for high efficiency applications.

The TGF2022-48 is also ideally suited for Point-to-point Radio, High-reliability space, and Military applications.

The TGF2022-48 has a protective surface passivation layer providing environmental robustness.

Lead-free and RoHS compliant

Key Features and Performance

- Frequency Range: DC - 20 GHz
- > 37 dBm Nominal Psat
- 58% Maximum PAE
- 45 dBm Nominal OIP3
- 13 dB Nominal Power Gain
- Suitable for high reliability applications
- 4.8mm x 0.35um Power pHEMT
- Nominal Bias Vd = 8-12V, Idq = 360-600mA (Under RF Drive, Id rises from 360mA to 1200mA)
- Chip Dimensions: 0.57 x 2.42 x 0.10 mm (0.022 x 0.095 x 0.004 in)

Primary Applications

- Point-to-point Radio
- High-reliability space
- Military
- Base Stations
- Broadband Wireless Applications

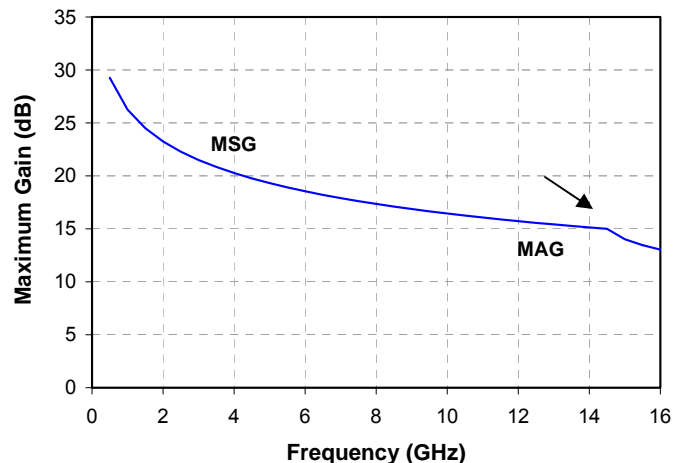

**TABLE I
MAXIMUM RATINGS**

TGF2022-48

Symbol	Parameter <u>1/</u>	Value	Notes
V ⁺	Positive Supply Voltage	12.5 V	<u>2/</u>
V ⁻	Negative Supply Voltage Range	-5V to 0V	
I ⁺	Positive Supply Current	2250 mA	<u>2/</u>
I _G	Gate Supply Current	56 mA	
P _{IN}	Input Continuous Wave Power	32 dBm	<u>2/</u>
P _D	Power Dissipation	See note 3	<u>2/ 3/</u>
T _{CH}	Operating Channel Temperature	150 °C	<u>4/</u>
T _M	Mounting Temperature (30 Seconds)	320 °C	
T _{STG}	Storage Temperature	-65 to 150 °C	

- 1/ These ratings represent the maximum operable values for this device.
- 2/ Combinations of supply voltage, supply current, input power, and output power shall not exceed P_D.
- 3/ For a median life time of 1E+6 hrs, Power dissipation is limited to:

$$P_{D(max)} = (150\text{ °C} - T_{BASE}\text{ °C}) / 17.3\text{ (°C/W)}$$
- 4/ Junction operating temperature will directly affect the device median time to failure (T_M). For maximum life, it is recommended that junction temperatures be maintained at the lowest possible levels.

**TABLE II
DC PROBE CHARACTERISTICS
(T_A = 25 °C, Nominal)**

Symbol	Parameter	Minimum	Typical	Maximum	Unit
I _{DSS}	Saturated Drain Current	-	1440	-	mA
G _m	Transconductance	-	1800	-	mS
V _P	Pinch-off Voltage	-1.5	-1	-0.5	V
V _{BGS}	Breakdown Voltage Gate-Source	-30	-	-8	V
V _{BGD}	Breakdown Voltage Gate-Drain	-30	-	-14	V

Note: For TriQuint's 0.35um power pHEMT devices, RF breakdown >> DC breakdown

TABLE III
RF CHARACTERIZATION TABLE 1/
 (T_A = 25 °C, Nominal)

TGF2022-48

SYMBOL	PARAMETER	f = 10 GHz		f = 18 GHz		UNITS
		Vd = 10V Idq = 360 mA	Vd = 12V Idq = 360 mA	Vd = 10V Idq = 360 mA	Vd = 12V Idq = 360 mA	
Power Tuned:						
Psat	Saturated Output Power	37.9	38.6	37.1	37.7	dBm
PAE	Power Added Efficiency	52.4	51.9	41.5	37.0	%
Gain	Power Gain	12.9	12.9	8.3	8.0	dB
Γ_L 2/	Load Reflection coefficient	0.870 \angle 173.9	0.857 \angle 171.8	0.911 \angle 173.9	0.917 \angle 173.4	-
Efficiency Tuned:						
Psat	Saturated Output Power	37.3	36.5	38.3	37.1	dBm
PAE	Power Added Efficiency	58.3	56.0	46.0	42.5	%
Gain	Power Gain	13	13	8.5	8.3	dB
Γ_L 2/	Load Reflection coefficient	0.856 \angle 169.8	0.858 \angle 169.5	0.930 \angle 173.3	0.94 \angle 172.8	-
OIP3	Output TOI	46	45	46	45	dBm

1/ Values in this table are from measurements taken from a 0.6mm unit pHEMT cell at 10 and 18 GHz

2/ Optimum load impedance for maximum power or maximum PAE at 10 and 18 GHz

TABLE IV
THERMAL INFORMATION

Parameter	Test Conditions	T _{CH} (°C)	θ _{JC} (°C/W)	T _M (HRS)
θ _{JC} Thermal Resistance (channel to backside of carrier)	Vd = 12 V Idq = 360 mA Pdiss = 4.32 W	145	17.3	1.6 E+6

Note: Assumes eutectic attach using 1.5 mil 80/20 AuSn mounted to a 20 mil CuMo Carrier at 70°C baseplate temperature.

Linear Model for 0.6 mm Unit pHEMT cell

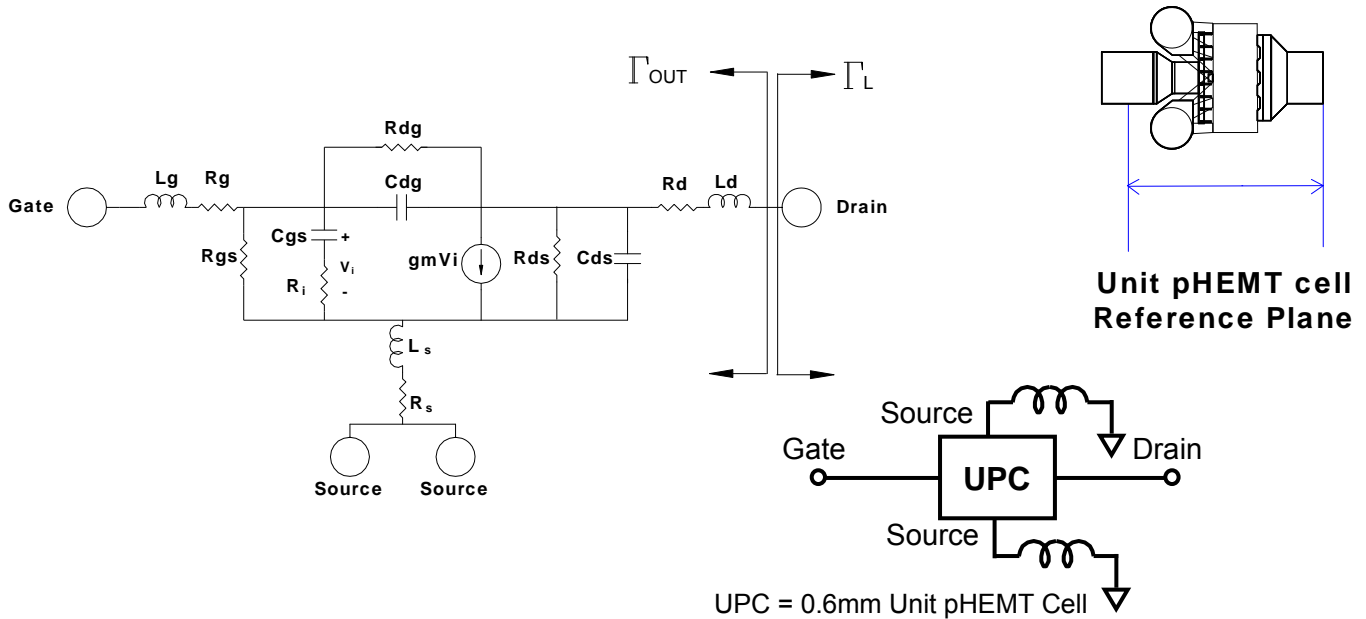

MODEL PARAMETER	Vd = 8V Idq = 45mA	Vd = 8V Idq = 60mA	Vd = 8V Idq = 75mA	Vd = 10V Idq = 45mA	Vd = 10V Idq = 60mA	Vd = 12V Idq = 45mA	UNITS
Rg	0.22	0.23	0.24	0.23	0.24	0.24	Ω
Rs	0.40	0.41	0.41	0.46	0.45	0.50	Ω
Rd	0.51	0.52	0.52	0.50	0.50	0.48	Ω
gm	0.195	0.202	0.202	0.188	0.195	0.183	S
Cgs	1.50	1.63	1.70	1.64	1.73	1.71	pF
Ri	1.65	1.59	1.58	1.72	1.64	1.73	Ω
Cds	0.115	0.115	0.116	0.114	0.115	0.114	pF
Rds	243.14	247.08	255.12	278.72	279.31	302.49	Ω
Cgd	0.072	0.066	0.063	0.064	0.061	0.060	pF
Tau	5.94	6.23	6.51	6.85	6.95	7.36	pS
Ls	0.001	0.001	0.001	0.001	0.001	0.001	nH
Lg	0.108	0.108	0.108	0.108	0.108	0.108	nH
Ld	0.121	0.120	0.118	0.118	0.118	0.117	nH
Rgs	5110	5140	8310	5110	5420	5120	Ω
Rgd	57700	64800	74400	79400	82900	82300	Ω

Linear Model for 4.8mm pHEMT

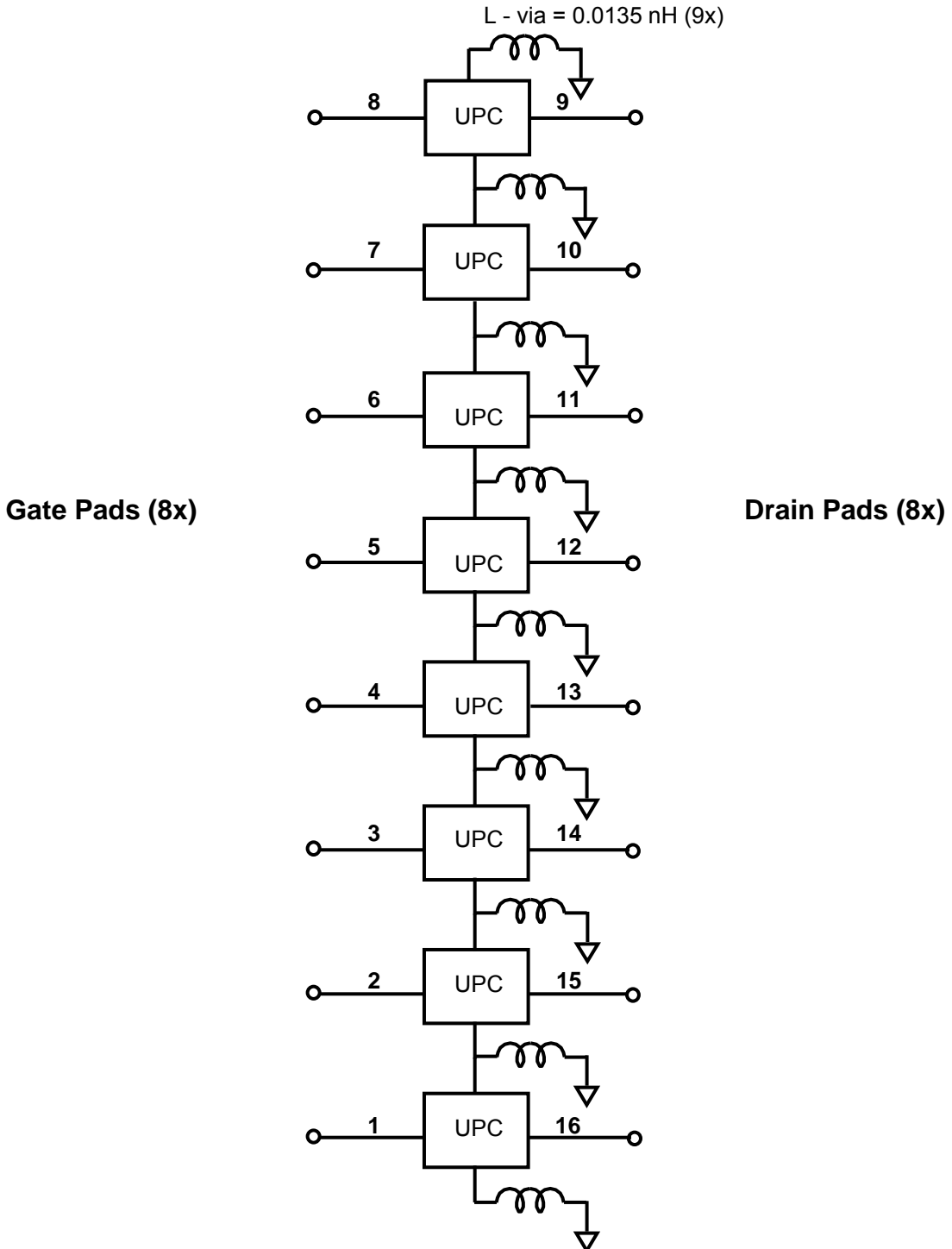

Unmatched S-parameters for 4.8 mm pHEMT

Bias Conditions: Vd = 12V, Idq = 360mA

Frequency (GHz)	s11 dB	s11 ang deg	s21 dB	s21 ang deg	s12 dB	s12 ang deg	s22 dB	s22 ang deg
0.5	-0.325	-154.69	22.299	100.31	-36.239	12.13	-4.759	-167.50
1	-0.288	-167.22	16.442	90.63	-36.078	4.39	-4.554	-171.69
1.5	-0.280	-171.50	12.929	85.31	-36.075	0.99	-4.470	-172.31
2	-0.276	-173.66	10.408	81.12	-36.105	-1.27	-4.388	-172.05
2.5	-0.272	-174.97	8.431	77.41	-36.153	-3.07	-4.296	-171.49
3	-0.270	-175.86	6.797	73.96	-36.214	-4.61	-4.191	-170.82
3.5	-0.267	-176.50	5.399	70.66	-36.287	-5.99	-4.076	-170.14
4	-0.264	-176.99	4.170	67.48	-36.371	-7.25	-3.953	-169.49
4.5	-0.260	-177.38	3.071	64.39	-36.464	-8.42	-3.822	-168.89
5	-0.257	-177.70	2.072	61.39	-36.567	-9.50	-3.687	-168.37
5.5	-0.253	-177.97	1.154	58.45	-36.678	-10.51	-3.548	-167.91
6	-0.250	-178.21	0.303	55.59	-36.797	-11.45	-3.409	-167.54
6.5	-0.246	-178.41	-0.494	52.79	-36.922	-12.32	-3.270	-167.23
7	-0.242	-178.60	-1.244	50.05	-37.054	-13.12	-3.133	-167.00
7.5	-0.238	-178.77	-1.953	47.37	-37.192	-13.85	-2.998	-166.83
8	-0.234	-178.92	-2.627	44.75	-37.334	-14.53	-2.867	-166.72
8.5	-0.230	-179.06	-3.270	42.19	-37.481	-15.13	-2.739	-166.67
9	-0.226	-179.20	-3.886	39.69	-37.632	-15.68	-2.616	-166.66
9.5	-0.222	-179.33	-4.477	37.24	-37.786	-16.16	-2.498	-166.70
10	-0.219	-179.45	-5.045	34.84	-37.942	-16.58	-2.385	-166.78
10.5	-0.215	-179.57	-5.592	32.50	-38.101	-16.94	-2.276	-166.90
11	-0.211	-179.68	-6.121	30.21	-38.261	-17.25	-2.173	-167.04
11.5	-0.208	-179.79	-6.632	27.97	-38.423	-17.49	-2.074	-167.21
12	-0.204	-179.89	-7.127	25.78	-38.586	-17.69	-1.981	-167.40
12.5	-0.201	-180.00	-7.607	23.64	-38.748	-17.82	-1.892	-167.61
13	-0.198	179.90	-8.073	21.54	-38.911	-17.90	-1.807	-167.83
13.5	-0.195	179.81	-8.525	19.48	-39.074	-17.93	-1.727	-168.07
14	-0.192	179.71	-8.965	17.47	-39.236	-17.91	-1.651	-168.32
14.5	-0.189	179.61	-9.392	15.50	-39.397	-17.84	-1.579	-168.58
15	-0.186	179.52	-9.808	13.56	-39.557	-17.73	-1.510	-168.85
15.5	-0.184	179.43	-10.214	11.66	-39.716	-17.56	-1.446	-169.12
16	-0.181	179.34	-10.609	9.80	-39.872	-17.35	-1.384	-169.40
16.5	-0.179	179.25	-10.994	7.97	-40.027	-17.10	-1.326	-169.68
17	-0.176	179.16	-11.370	6.18	-40.180	-16.80	-1.271	-169.96
17.5	-0.174	179.07	-11.737	4.42	-40.330	-16.47	-1.219	-170.24
18	-0.172	178.99	-12.096	2.69	-40.478	-16.09	-1.169	-170.53
18.5	-0.170	178.90	-12.446	0.98	-40.623	-15.68	-1.122	-170.81
19	-0.168	178.82	-12.789	-0.69	-40.765	-15.23	-1.077	-171.10
19.5	-0.166	178.73	-13.124	-2.34	-40.904	-14.74	-1.034	-171.38
20	-0.164	178.65	-13.451	-3.97	-41.039	-14.22	-0.994	-171.66
20.5	-0.162	178.57	-13.772	-5.57	-41.172	-13.66	-0.955	-171.95
21	-0.161	178.48	-14.087	-7.14	-41.300	-13.08	-0.919	-172.22
21.5	-0.159	178.40	-14.394	-8.70	-41.425	-12.46	-0.884	-172.50
22	-0.157	178.32	-14.696	-10.23	-41.547	-11.82	-0.851	-172.78
22.5	-0.156	178.24	-14.992	-11.75	-41.664	-11.14	-0.819	-173.05
23	-0.155	178.16	-15.283	-13.24	-41.778	-10.44	-0.789	-173.32
23.5	-0.153	178.08	-15.568	-14.72	-41.887	-9.72	-0.760	-173.59
24	-0.152	178.01	-15.848	-16.18	-41.992	-8.97	-0.733	-173.85
24.5	-0.151	177.93	-16.123	-17.63	-42.093	-8.20	-0.706	-174.12
25	-0.149	177.85	-16.393	-19.05	-42.189	-7.41	-0.681	-174.38
25.5	-0.148	177.77	-16.659	-20.47	-42.281	-6.61	-0.657	-174.63
26	-0.147	177.70	-16.920	-21.87	-42.369	-5.78	-0.634	-174.89

Note: The s-parameters are calculated by connecting nodes 1-8 together, and nodes 9-16 together to form a 2-port network.

Mechanical Drawing

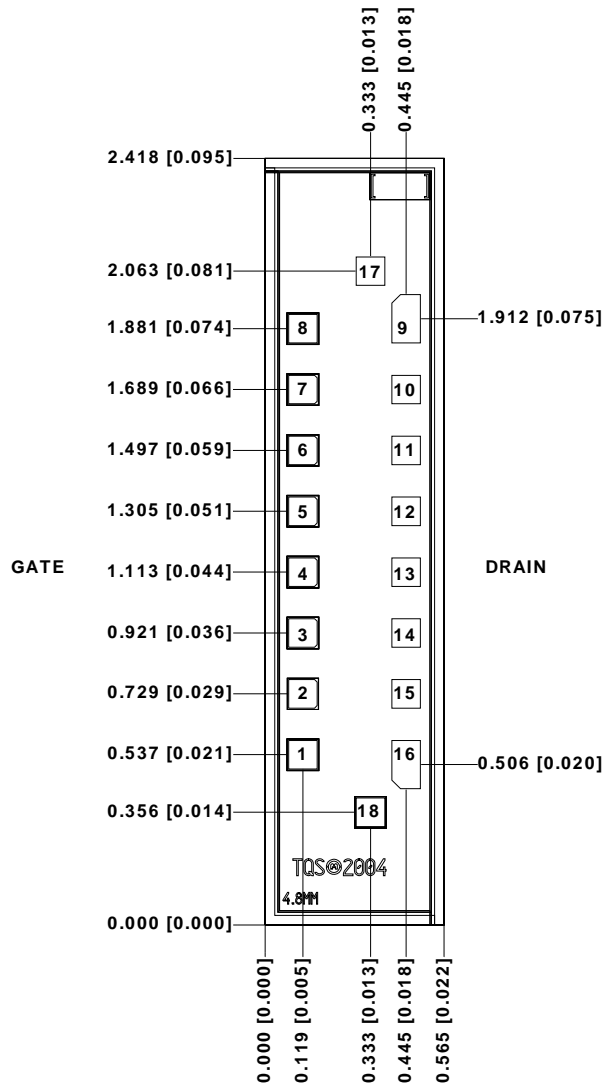

Units: millimeters (inches)

Thickness: 0.100 (0.004)

Chip edge to bond pad dimensions are shown to center of bond pad

Chip size tolerance: +/- 0.051 (0.002)

GND IS BACKSIDE OF MMIC

Bond pads #1-8: (Gate) 0.090 x 0.090 (0.004 x 0.004)

Bond pads #9-16: (Drain) 0.090 x 0.090 (0.004 x 0.004)

Bond pad #17: (Vg*) 0.090 x 0.090 (0.004 x 0.004)

Bond pad #18: (Vg*) 0.090 x 0.090 (0.004 x 0.004)

*Note: Bond pads #17 & 18 are alternate gate pads that can be used for paralleling FETs.

GaAs MMIC devices are susceptible to damage from Electrostatic Discharge. Proper precautions should be observed during handling, assembly and test.

Assembly Process Notes

Reflow process assembly notes:

- Use AuSn (80/20) solder with limited exposure to temperatures at or above 300 °C for 30 sec
- An alloy station or conveyor furnace with reducing atmosphere should be used.
- No fluxes should be utilized.
- Coefficient of thermal expansion matching is critical for long-term reliability.
- Devices must be stored in a dry nitrogen atmosphere.

Component placement and adhesive attachment assembly notes:

- Vacuum pencils and/or vacuum collets are the preferred method of pick up.
- Air bridges must be avoided during placement.
- The force impact is critical during auto placement.
- Organic attachment can be used in low-power applications.
- Curing should be done in a convection oven; proper exhaust is a safety concern.
- Microwave or radiant curing should not be used because of differential heating.
- Coefficient of thermal expansion matching is critical.

Interconnect process assembly notes:

- Thermosonic ball bonding is the preferred interconnect technique.
- Force, time, and ultrasonics are critical parameters.
- Aluminum wire should not be used.
- Devices with small pad sizes should be bonded with 0.0007-inch wire.
- Maximum stage temperature is 200 °C.