

Dual 1.5 A, DC/DC Step-Down Converter

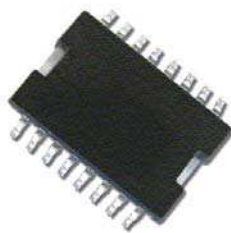
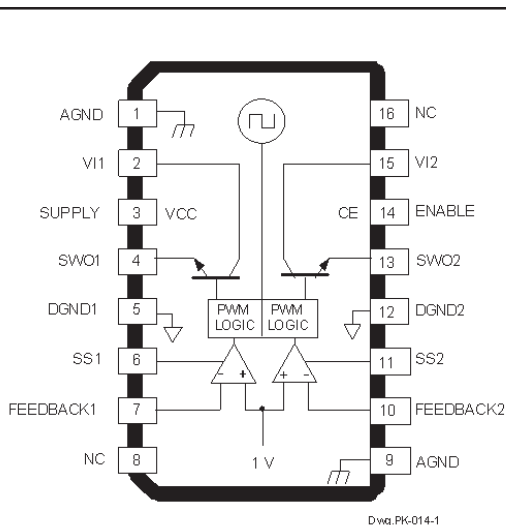

ABSOLUTE MAXIMUM RATINGS

Input Voltage, V_I , V_{CC} , V_{CE} **21 V**

Output Current, I_O **1.5 A***

Junction Temperature, T_J **+135°C**

Storage Temperature Range,
 T_S **-40°C to +135°C**

* Output current rating is limited by input voltage, duty cycle, and ambient temperature. Under any set of conditions, do not exceed a junction temperature of +135°C.

Designed to meet high-current requirements at high efficiency in industrial and consumer applications; embedded core, memory, or logic supplies; TVs, VCRs, and office equipment, the SPI-8001TW dc/dc step-down (buck) converter offers a constant 250 kHz switching frequency essential for small external components. The n-channel high-current FET is included on the die along with the oscillator, control, and logic circuitry.

A wide input voltage range and integrated thermal and overcurrent protection enhance overall system reliability. Reference accuracy and excellent temperature characteristics are provided. A chip-enable input gives the designer complete control over power up, standby, or power down. A similar device, with increased input and output voltage ratings, is the SPI-8002TW.

This device is supplied in a 16-lead surface-mount plastic SOIC with exposed pad to provide a low-resistance path for maximum power dissipation, low junction temperature, and improved reliability.

FEATURES

- To 20 V Input Range
- Adjustable 1 V to 16 V Output Range
- 1% Output Voltage Tolerance
- To 1.5 A Output Current
- Foldback Current Limiting
- Constant 250 kHz Switching Frequency
- 1.0 μ A Maximum Standby Current
- 1.0 V Feedback Reference Voltage
- Soft Start Avoids Supply Voltage Dip
- Remote Voltage Sensing
- Exposed Pad for Superior Heat Dissipation
- Thermal Protection

APPLICATIONS

- TVs, VCRs, Electronic Games
- Embedded Core, Memory, or Logic Supplies
- Printers and Other Office Equipment
- Industrial Machinery

Always order by complete part number, e.g., **SPI-8001TW-TL**, where "-TL" indicates tape and reel.

SPI-8001TW

Dual 1.5 A, DC/DC Step-Down Converter

Switching Regulators

FUNCTIONAL BLOCK DIAGRAM

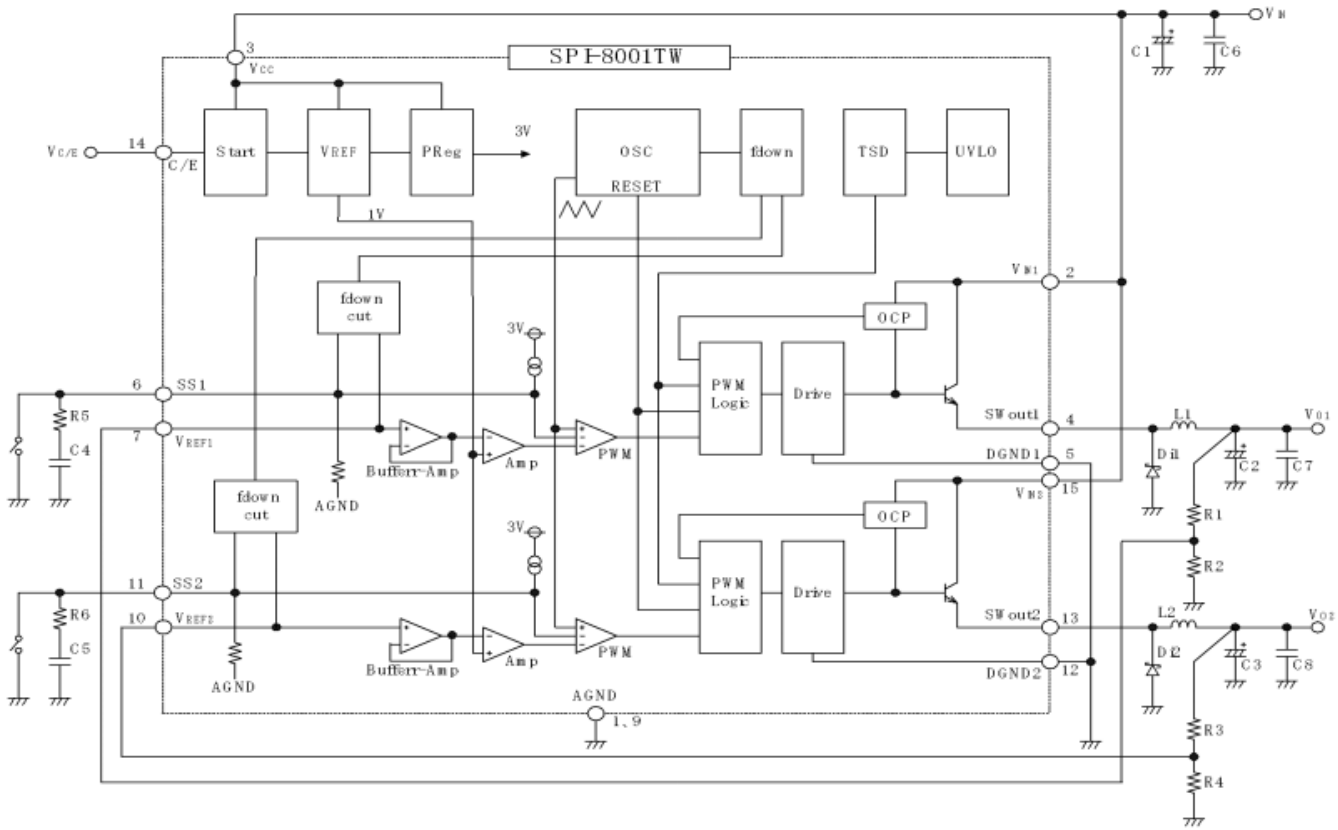

Allowable Package Power Dissipation

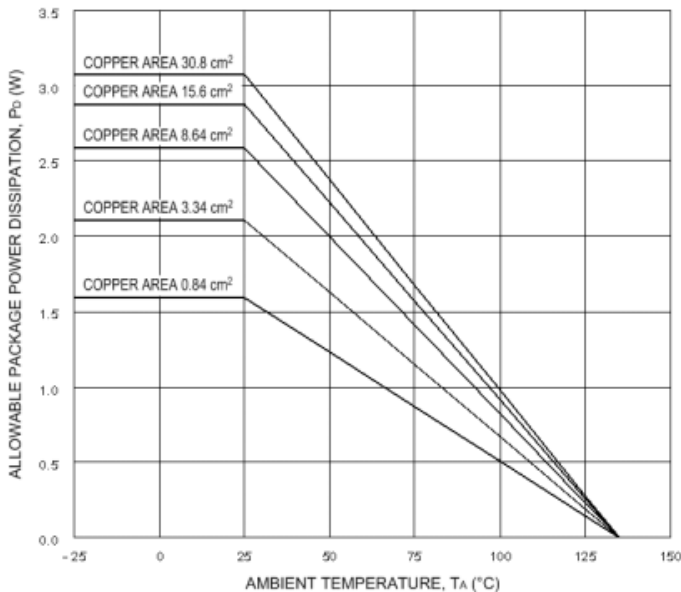

Recommended Operating Conditions

	Min	Max	Units
DC Input Voltage, V_{I1}^*	$V_O + 3$	20	V
DC Input Voltage, V_{CC}	4.5	20	V
DC Output Current, I_O	0	1.5	A
DC Output Voltage, V_O	1	16	V
Operating Junction Temp.	-30	+135	°C†

*The recommended maximum value is 20 V when the output value is more than 2 V, derated linearly to 10 V when the output is 1 V.

†For the availability of parts meeting -40°C requirements, contact Sanken's Sales Representative.

This data sheet is based on Sanken data sheet SSJ-02097E

ELECTRICAL CHARACTERISTICS at $T_A = +25^\circ\text{C}$, $V_I = V_{CC} = 15\text{ V}$ (unless otherwise noted).

Characteristic	Symbol	Test Conditions	Limits			
			Min.	Typ.	Max.	Units
Internal Reference Voltage	V_{ref}	$V_I = 10\text{ V}$, $V_O = 1\text{ V}$, $I_O = 0.1\text{ A}$	0.996	1.006	1.016	V
Ref. Volt. Temp. Coeff.	$a_{V_{\text{ref}}}$	$V_I = 10\text{ V}$, $V_O = 1\text{ V}$, $I_O = 0.1\text{ A}$	—	± 0.1	—	mV/°C
Output Short-Circuit Current	I_{OM}	See note	1.6	—	—	A
Efficiency	η	$V_O = 5\text{ V}$, $I_O = 0.5\text{ A}$, I_I includes I_{CC}	—	80	—	%
		$V_{\text{CC}} = 5\text{ V}$, $V_O = 5\text{ V}$, $I_O = 0.5\text{ A}$, I_I does not include I_{CC}	—	83	—	%
Operating Frequency	f	$V_O = 5\text{ V}$, $I_O = 0.5\text{ A}$	—	250	—	kHz
Line Regulation	$\Delta V_{O(\Delta V_I)}$	$V_I = V_{\text{CC}} = 10\text{ V} \sim 20\text{ V}$, $V_O = 5\text{ V}$, $I_O = 1\text{ A}$	—	30	60	mV
Load Regulation	$\Delta V_{O(\Delta I_O)}$	$V_O = 5\text{ V}$, $I_O = 0.2\text{ A} \sim 1.5\text{ A}$	—	10	40	mV
Supply Current	I_{CC}	$I_O = 0\text{ A}$	—	8.5	—	mA
Quiescent Current	I_{IQ}	$V_{\text{CC}} = 5\text{ V}$, $I_O = 0\text{ A}$, $V_O \leq 12\text{ V}$	—	4.0	—	mA
		$V_{\text{CE}} = 0\text{ V}$ or open	—	—	1.0	μA
	I_{CCQ}	$V_{\text{CE}} = 0\text{ V}$ or open	—	—	1.0	μA
Chip Enable Voltage	V_{CEH}		2.0	—	—	V
	V_{CEL}		—	—	0.8	V
Chip Enable Input Current	I_{CE}	$V_{\text{CE}} = 20\text{ V}$	—	95	—	μA
Soft-Start Voltage	V_{SS}	Converter turn-off voltage	—	—	0.5	V
Soft-Start Current	I_{SS}	$V_{\text{SS}} = 0\text{ V}$	—	-60	-80	μA

Typical values are given for circuit design information only.

Note: Output short-circuit current is at point where output voltage has decreased 5% below $V_{O(\text{nom})}$.

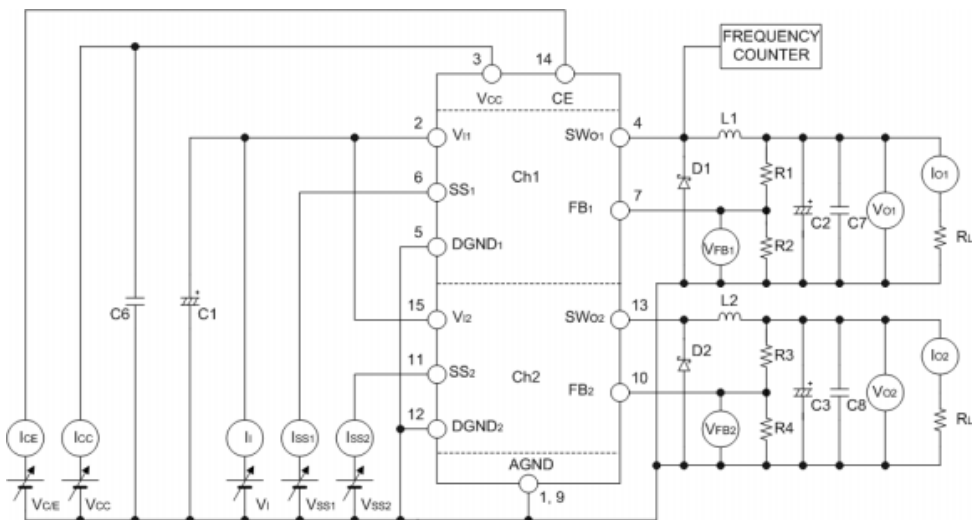

Test Circuit

SPI-8001TW

Dual 1.5 A, DC/DC

Step-Down Converter

Switching
Regulators

TYPICAL CHARACTERISTICS

($T_A = 25^\circ\text{C}$)

■ Efficiency

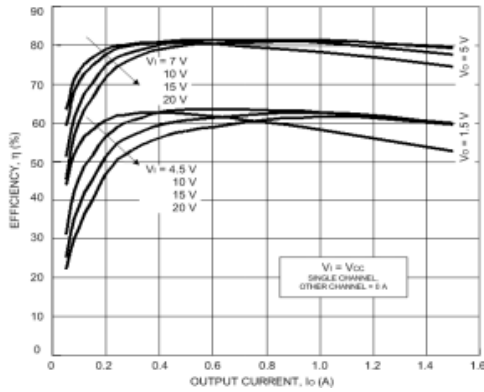

■ Efficiency

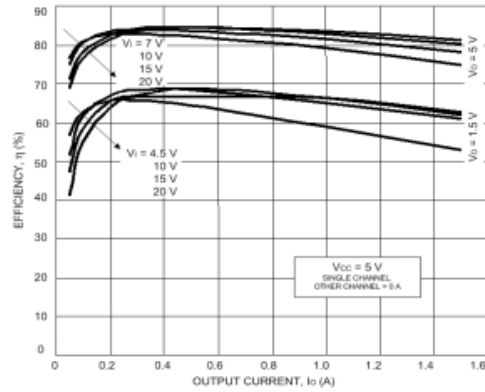

■ Low-Voltage Behavior

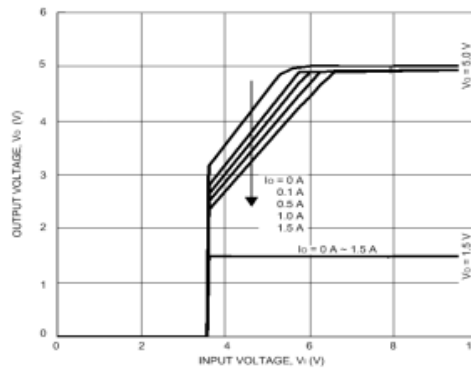

■ Load Regulation

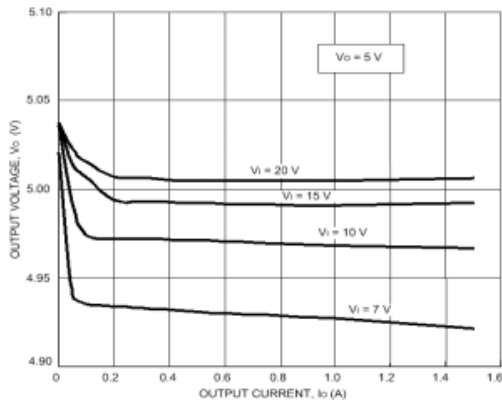

■ Load Regulation

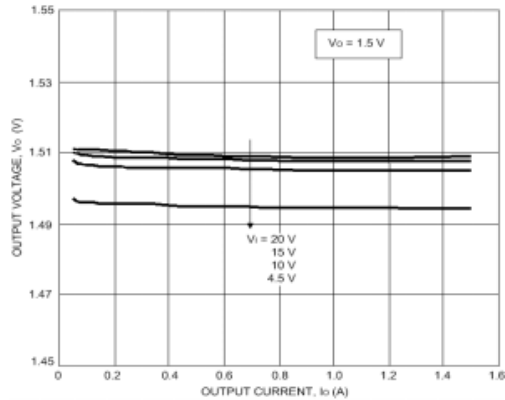

TYPICAL CHARACTERISTICS (cont.)

($T_A = 25^\circ\text{C}$)

■ Overcurrent Protection

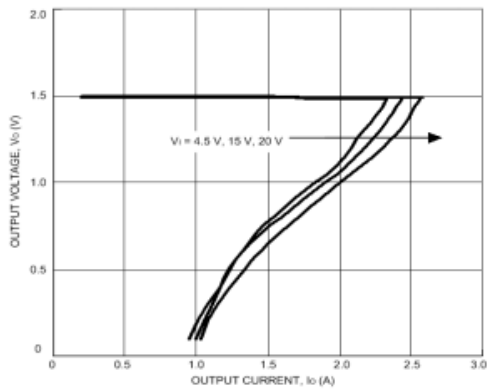

■ Overcurrent Protection

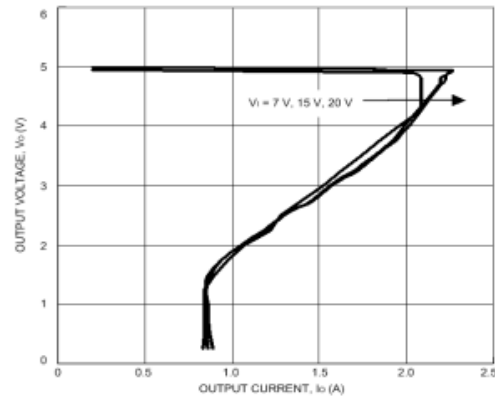

■ Temperature Stability

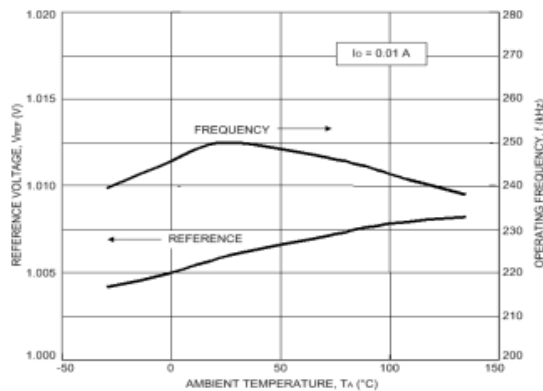

■ Soft-Start Current

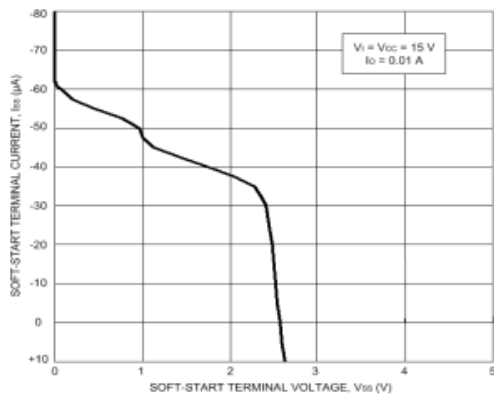

■ Chip Enable Control Voltage

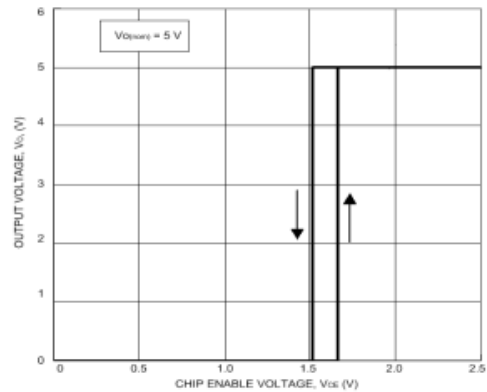

SPI-8001TW
Dual 1.5 A, DC/DC
Step-Down Converter

Switching
Regulators

APPLICATIONS INFORMATION

Input Capacitors (C1 and C6). Capacitors with low impedance for high-frequency ripple current must be used.

Output Capacitors (C2, C3, C7, and C8). Capacitors with low impedance for high-frequency ripple current must be used. Especially when the C2 and C3 impedance is high, the switching waveform may not be normal at low temperatures. Film or tantalum capacitors for C2 and C3 may cause abnormal oscillations.

Catch Diodes (D1 and D2). Diode D1 and D2 must be Schottky diodes. Other diode types will result in increased forward voltage spikes, reverse current flow, increased IC power dissipation during the off period, and possible destruction of the IC.

Choke Coils (L1 and L2). If the winding resistance of the choke coil is too high, the circuit efficiency will decrease. As the overcurrent protection start current is approximately 2 A, attention must be paid to the heating of the coil by magnetic saturation due to overload. To reduce the output ripple, the inductor may be increased at the expense of excessive board area and cost.

Output Voltage Adjustable Resistors (R1, R2, R3, and R4). The output voltages are adjusted by R1 and R3. 1000 Ω for R2 and R4 is recommended.

$$R1 = (V_{O1} - V_{ref}) / (V_{ref} / R2)$$

$$R3 = (V_{O2} - V_{ref}) / (V_{ref} / R4)$$

Soft-Start Capacitors (C4 and C5). Soft start for each converter channel is enabled by connecting a capacitor between terminal 6 and/or 11 and ground. The channel may be turned off by decreasing the terminal 6 and/or 11 voltage below 0.5 V with either an npn small-signal transistor or the output of open-collector TTL. If both a large soft-start capacitor and on/off control are desired, collector current limiting (R5 and R6) must be used to prevent transistor damage. No external voltage can be applied to terminal 6 or 11.

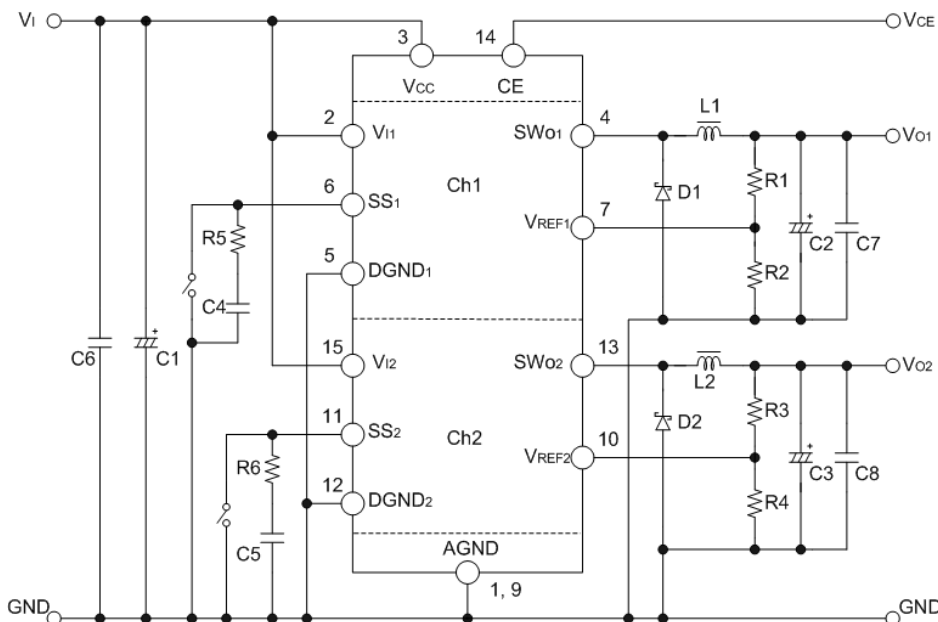
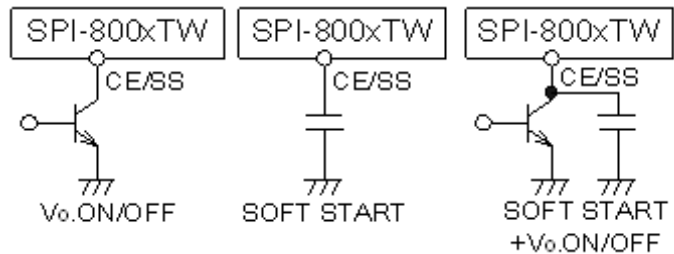

Typical Application

- | | |
|------------|----------------|
| C1 | 220 μF/63 V |
| C2, C3 | 470 μF/25 V |
| C4, C5 | 1 μF |
| C6, C7, C8 | 0.1 μF |
| R5, R6 | 1 kΩ |
| L1, L2 | 47 μH |
| D1, D2 | Sanken SFPB-66 |

APPLICATIONS INFORMATION (cont.)

Overcurrent Protection. The SPI-8000TW series has a built-in fold-back type overcurrent protection circuit, which limits the output current at a start-up mode. It thus cannot be used in applications that require current at the start-up mode such as:

- (1) constant-current load,
- (2) power supply with positive and negative outputs to common load (a center-tap type power supply), or
- (3) raising the output voltage by putting a diode or a resistor between the device ground and system ground.

Determination of DC Input Voltage. The minimum value of dc input voltage is $V_O + 3\text{ V}$. The recommended maximum value is 20 V when the output value is more than 2 V, derated linearly to 10 V when the output is 1 V.

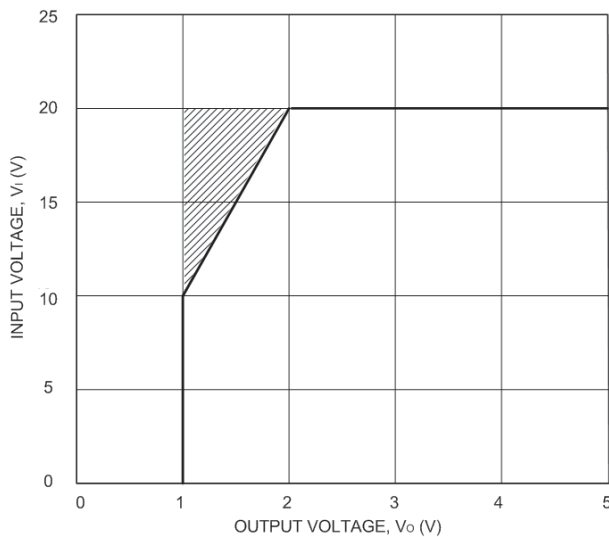

Parallel Operation. Parallel operation to increase load current is not permitted.

Thermal Protection. Circuitry turns off the device when the junction temperature rises above 135°C. It is intended only to protect the device from failures due to excessive junction temperatures and should not imply that output short circuits or continuous overloads are permitted.

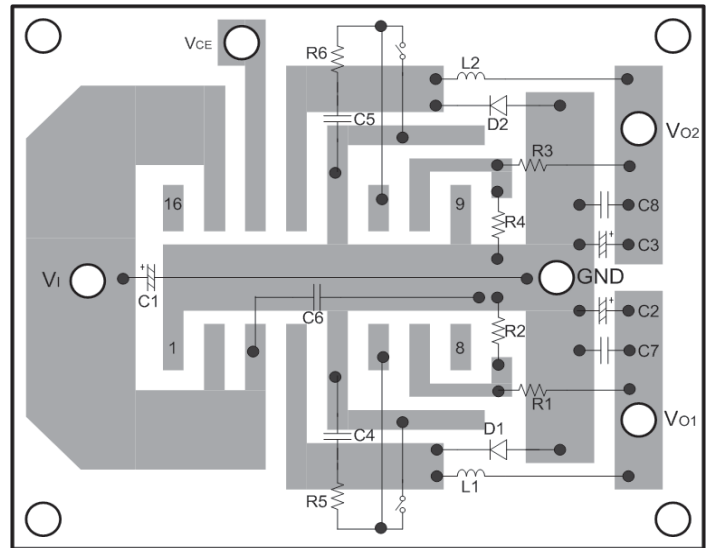

Layout Guideline

Heat Radiation and Reliability. The reliability of the IC is directly related to the junction temperature (T_J) in its operation. Accordingly, careful consideration should be given to heat dissipation.

The inner frame on which the integrated circuit is mounted is connected to the exposed pad. Therefore, it is very effective for heat radiation to enlarge the copper area that is connected to the pad. The graph on page 2 illustrates the effect of the copper area on the junction-to-ambient thermal resistance ($R_{\theta JA}$).

The junction temperature (T_J) can be determined from either of the following equations:

$$T_J = (P_D \times R_{\theta JA}) + T_A$$

or

$$T_J = (P_D \times R_{\theta JL}) + T_L$$

where

$$R_{\theta JL} = 9^\circ\text{C/W}$$

and

$$P_D = V_O \times I_O \left(\frac{100}{\eta x} - 1 \right) - V_F \times I_O \left(1 - \frac{V_O}{V_{IN}} \right)$$

where V_O is the output voltage, V_{IN} is the input voltage, I_O is the output current ηx is efficiency (%) and V_F is the diode forward voltage SFPB-66 (0.45 V, $I_O = 1\text{ A}$).

SPI-8001TW
Dual 1.5 A, DC/DC
Step-Down Converter

Switching
Regulators

Dimensions in Millimeters

Lead Temperature
 (T_L) Measured at
 Terminal 1 or 9

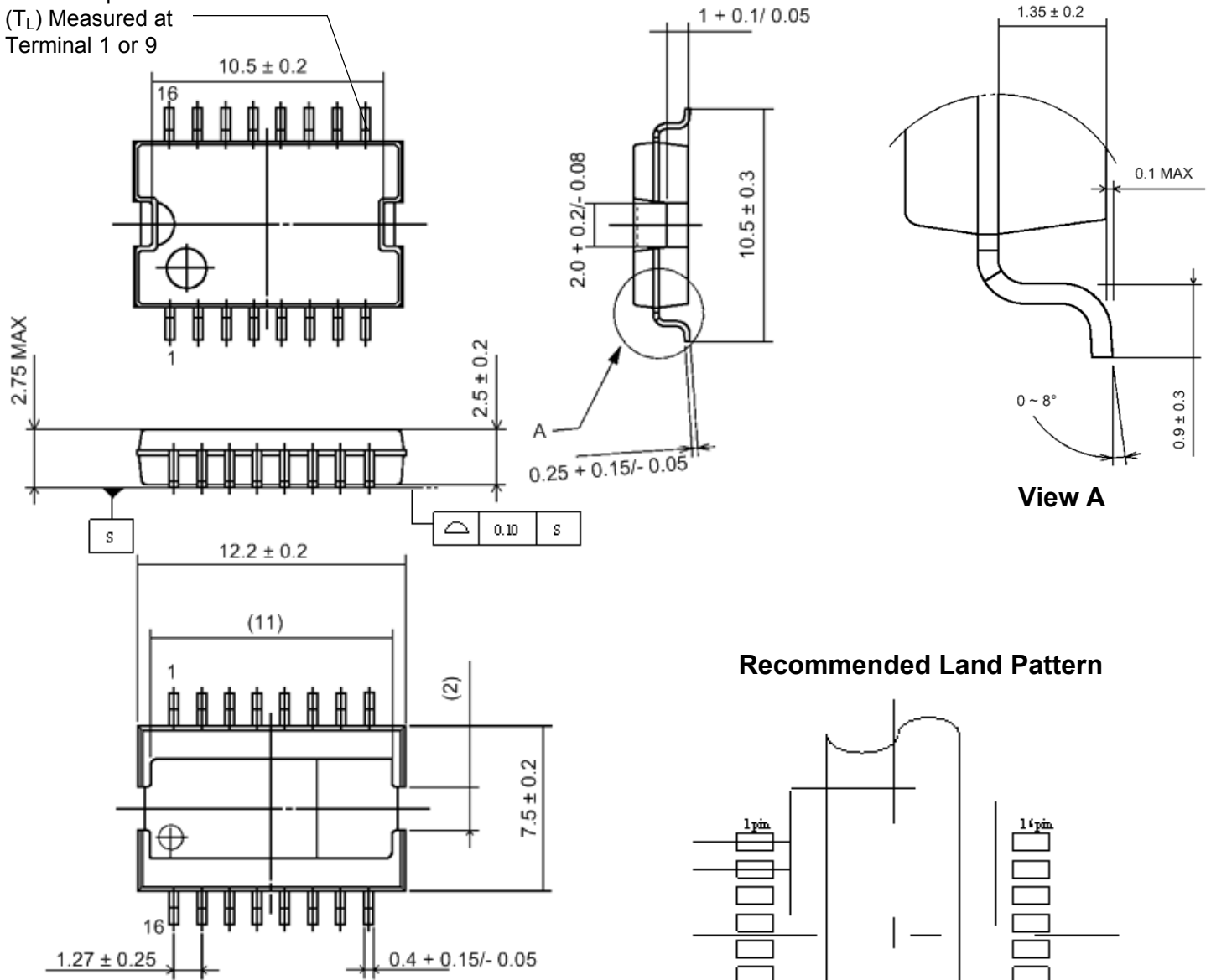

Recommended Land Pattern

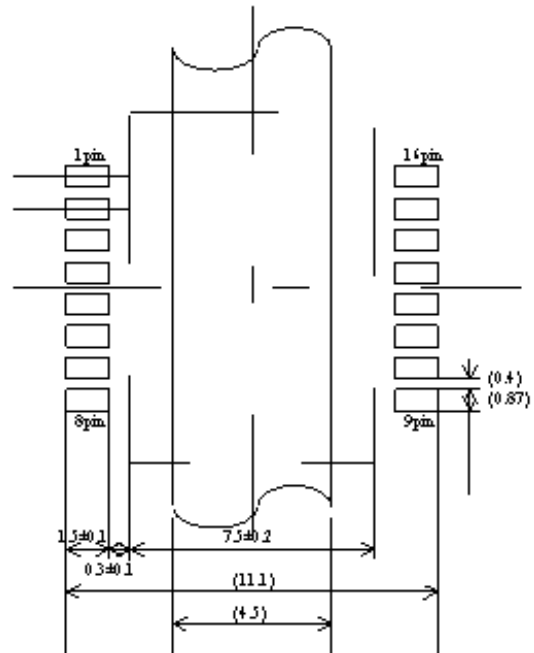

Product Weight: Approx. 0.859 g

-
- The contents in this document are subject to changes, for improvement and other purposes, without notice. Make sure that this is the latest revision of the document before use.
 - Application and operation examples described in this document are quoted for the sole purpose of reference for the use of the products herein and Sanken can assume no responsibility for any infringement of industrial property rights, intellectual property rights or any other rights of Sanken or any third party which may result from its use.
 - Although Sanken undertakes to enhance the quality and reliability of its products, the occurrence of failure and defect of semiconductor products at a certain rate is inevitable. Users of Sanken products are requested to take, at their own risk, preventative measures including safety design of the equipment or systems against any possible injury, death, fires or damages to the society due to device failure or malfunction.
 - Sanken products listed in this document are designed and intended for the use as components in general purpose electronic equipment or apparatus (home appliances, office equipment, telecommunication equipment, measuring equipment, etc.).

When considering the use of Sanken products in the applications where higher reliability is required (transportation equipment and its control systems, traffic signal control systems or equipment, fire/crime alarm systems, various safety devices, etc.), and whenever long life expectancy is required even in general purpose electronic equipment or apparatus, please contact your nearest Sanken sales representative to discuss, prior to the use of the products herein.

The use of Sanken products without the written consent of Sanken in the applications where extremely high reliability is required (aerospace equipment, nuclear power control systems, life support systems, etc.) is strictly prohibited.

- In the case that you use Sanken products or design your products by using Sanken products, the reliability largely depends on the degree of derating to be made to the rated values. Derating may be interpreted as a case that an operation range is set by derating the load from each rated value or surge voltage or noise is considered for derating in order to assure or improve the reliability. In general, derating factors include electric stresses such as electric voltage, electric current, electric power etc., environmental stresses such as ambient temperature, humidity etc. and thermal stress caused due to self-heating of semiconductor products. For these stresses, instantaneous values, maximum values and minimum values must be taken into consideration.

In addition, it should be noted that since power devices or IC's including power devices have large self-heating value, the degree of derating of junction temperature affects the reliability significantly.

- When using the products specified herein by either (i) combining other products or materials therewith or (ii) physically, chemically or otherwise processing or treating the products, please duly consider all possible risks that may result from all such uses in advance and proceed therewith at your own responsibility.
- Anti radioactive ray design is not considered for the products listed herein.
- Sanken assumes no responsibility for any troubles, such as dropping products caused during transportation out of Sanken's distribution network.
- The contents in this document must not be transcribed or copied without Sanken's written consent.