

Step-Down to 3.3 V, 1.5 A, DC/DC Converter

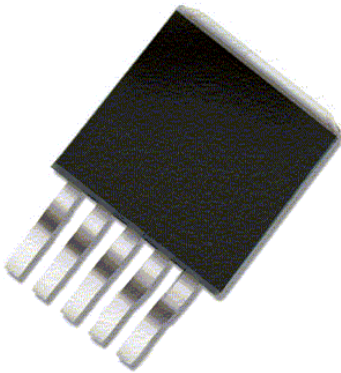
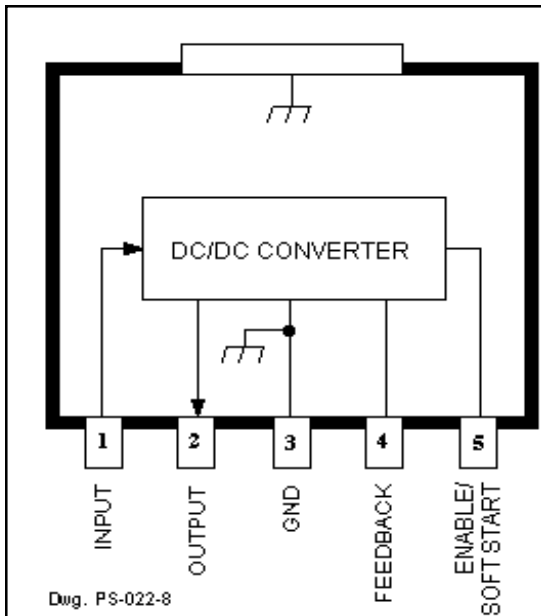

ABSOLUTE MAXIMUM RATINGS

Input Voltage, V_I	43 V
Output Current, I_O	1.5 A*
Enable Input Voltage, V_{OE}	6 V
Junction Temperature, T_J	+125°C
Storage Temperature Range, T_S	-40°C to +125°C

* Output current rating is limited by input voltage, duty cycle, and ambient temperature. Under any set of conditions, do not exceed a junction temperature of +125°C.

Designed to meet high-current requirements at high efficiency in industrial and consumer applications; embedded core, memory, or logic supplies; TVs, VCRs, and office or telecommunications equipment, the SI-8033JD dc/dc step-down (buck) converter offers a constant 125 kHz switching frequency essential for low EMI noise. The npn switch is included on the die along with the oscillator, control, and logic circuitry requiring only four external components for a regulated 3.3 V output at up to 1.5 A.

A wide input voltage range and integrated thermal and overcurrent protection enhance overall system reliability. Reference accuracy and excellent temperature characteristics are provided. An output-enable input gives the designer complete control over power up, standby, or power down.

This device is supplied in a 5-lead surface-mount plastic package (TO-263) with ground tab to provide a low-resistance path for maximum heat dissipation. A similar device in a flange-mounted (TO-220-style) high-power package is the SI-8033JF.

FEATURES

- 5.3 V to 40 V Input Range
- 1.5 A Output Current at 3.3 V
- 2% Output Voltage Tolerance
- Foldback Current Limiting
- Constant 125 kHz Switching Frequency
- 200 μ A Maximum Standby Current
- Soft Start Prevents Supply Voltage Dip
- Remote Voltage Sensing
- Exposed Pad for Superior Heat Dissipation
- Thermal Protection

APPLICATIONS

- TVs, VCRs, Electronic Games
- Embedded Core, Memory, or Logic Supplies
- Printers and Other Office Equipment
- Industrial Machinery
- Telecommunications Equipment

Always order by complete part number, e.g., **SI-8033JD-TL**, where "-TL" indicates tape and reel.

SI-8033JD
Step-Down
to 3.3 V, 1.5 A,
DC/DC Converter

Switching
Regulators

FUNCTIONAL BLOCK DIAGRAM

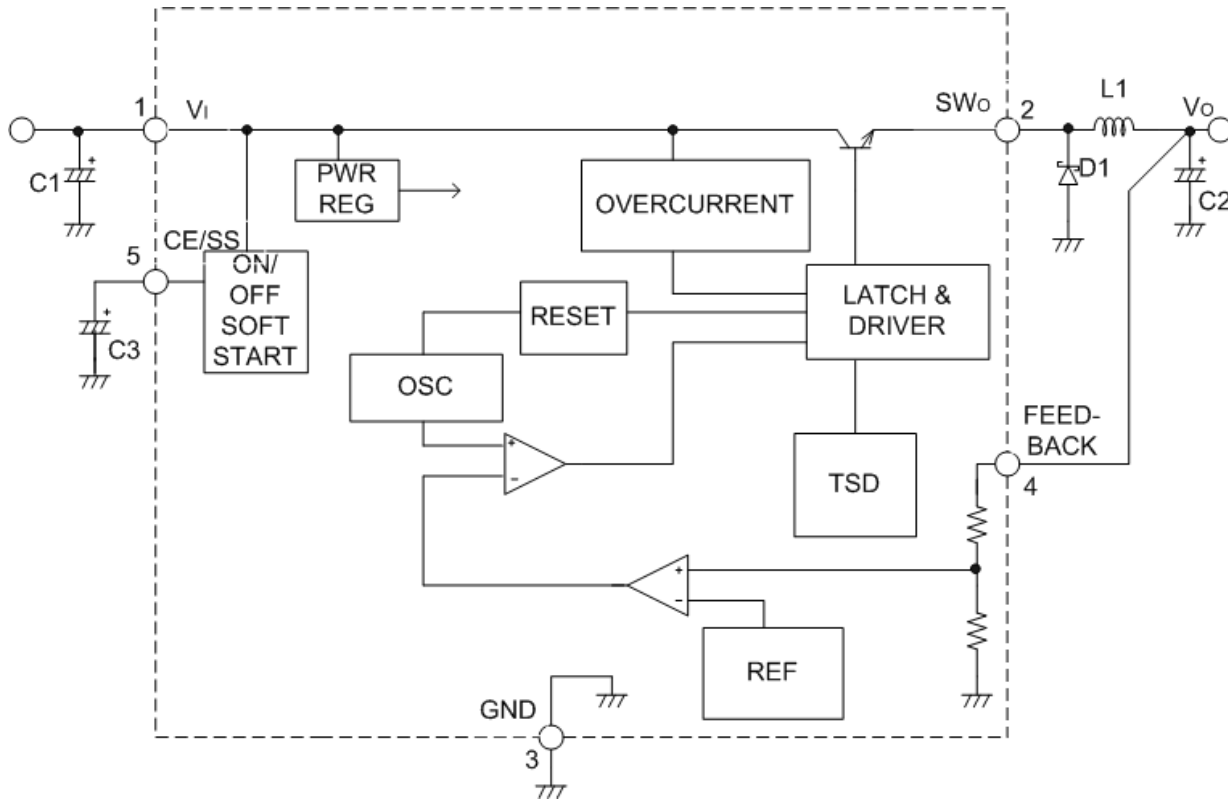

Allowable Package Power Dissipation

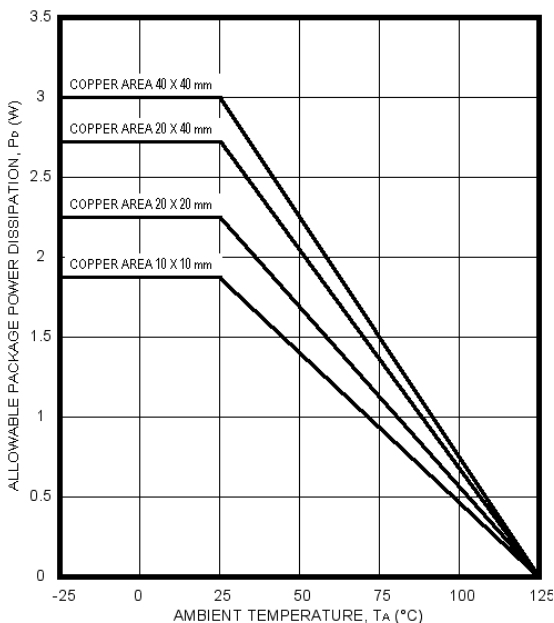

Dwg. 61K003-7A

Recommended Operating Conditions

	Min	Max	Units
DC Input Voltage ($I_o \leq 1 \text{ A}$)	5.3	6.3	V
($I_o \leq 1.5 \text{ A}$)	6.3	40	V
DC Output Current ($V_i \geq 6.3 \text{ V}$)	0	1.5	A
Operating Junction Temp.	-30	+125	°C

For the availability of parts meeting -40°C requirements, contact Sanken's Sales Representative.

This data sheet is based on Sanken data sheet SSJ-02530

ELECTRICAL CHARACTERISTICS at $T_A = +25^\circ\text{C}$, $V_I = 15\text{ V}$, $I_O = 0.5\text{ A}$ (unless otherwise noted).

Characteristic	Symbol	Test Conditions	Limits			
			Min.	Typ.	Max.	Units
Output Voltage	V_O		3.234	3.30	3.366	V
Ref. Volt. Temp. Coeff.	$a_{V_{ref}}$		—	± 0.5	—	mV/°C
Output Short-Circuit Current	I_{OM}	See note	1.6	—	—	A
Efficiency	η		—	77	—	%
Operating Frequency	f		—	125	—	kHz
Line Regulation	$\Delta V_{O(\Delta V_I)}$	$V_I = 8\text{ V} \sim 30\text{ V}$, $I_O = 0.5\text{ A}$	—	25	80	mV
Load Regulation	$\Delta V_{O(\Delta I_O)}$	$V_I = 15\text{ V}$, $I_O = 0.2\text{ A} \sim 0.8\text{ A}$	—	10	30	mV
Quiescent Current	I_{IQ}	$I_O = 0\text{ A}$	—	7.0	—	mA
		$V_{CE} = 0.3\text{ V}$	—	—	200	μA
Chip Enable Voltage	V_{CE}	Converter turn-off voltage	—	—	0.5	V
Soft-Start Current	I_{SS}	$V_{SS} = 0\text{ V}$	—	—	-100	μA

Typical values are given for circuit design information only.

Note: Output short-circuit current is at point where output voltage has decreased 5% below $V_{O(nom)}$.

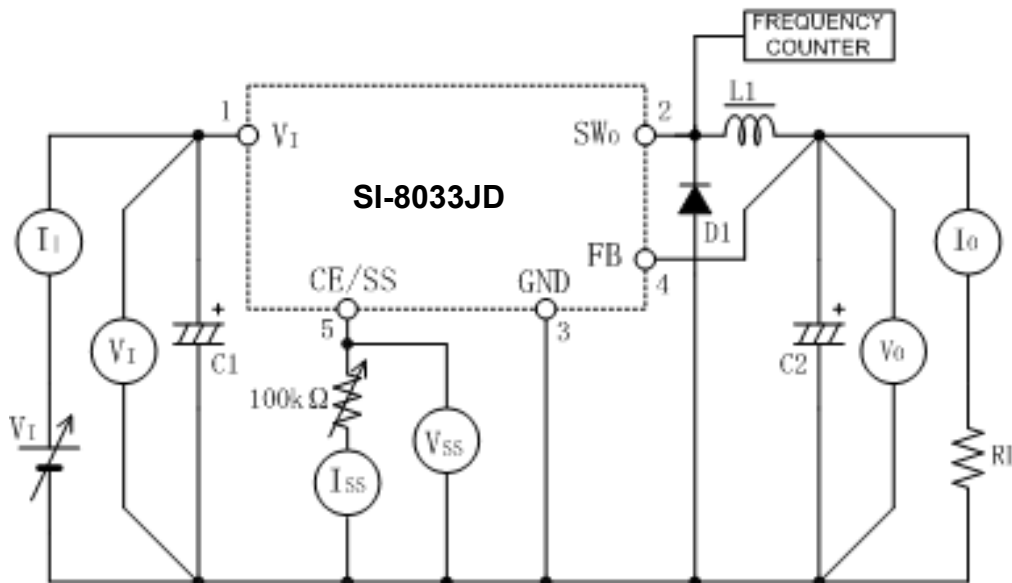

Test Circuit

- C1 = 220 $\mu\text{F}/50\text{ V}$
- C2 = 470 $\mu\text{F}/25\text{ V}$
- C3 = 0.47 $\mu\text{F}/10\text{ V}$
- L1 = 100 μH
- D1 = Sanken SFPB-66

SI-8033JD
Step-Down
to 3.3 V, 1.5 A,
DC/DC Converter

Switching
Regulators

TYPICAL CHARACTERISTICS

($T_A = 25^\circ\text{C}$)

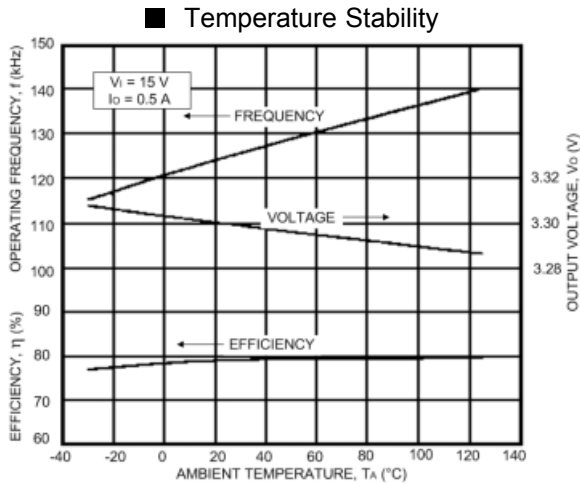
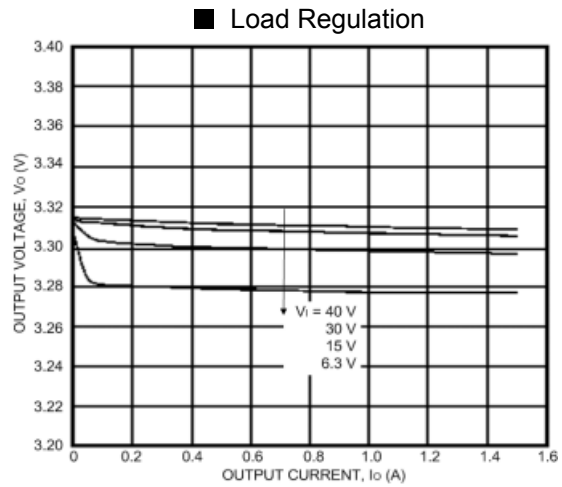
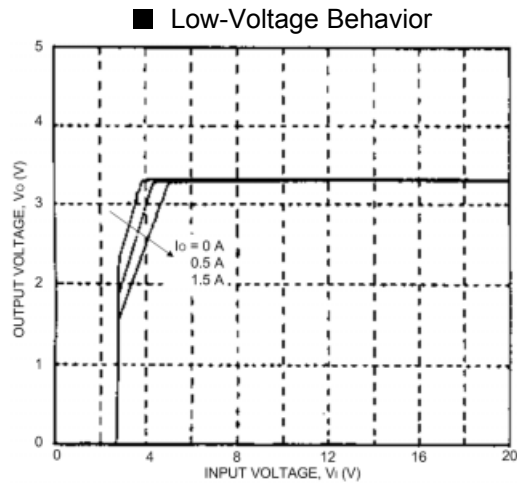
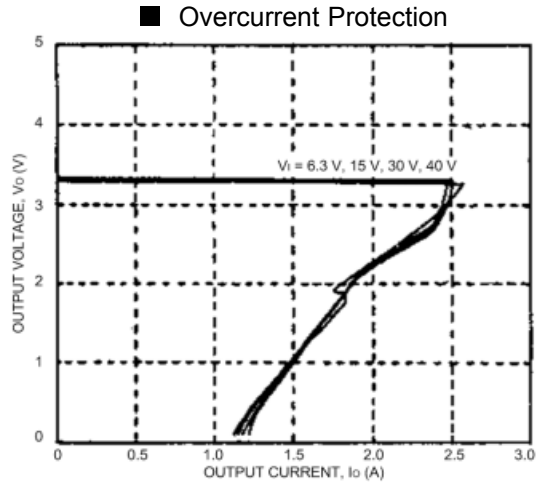
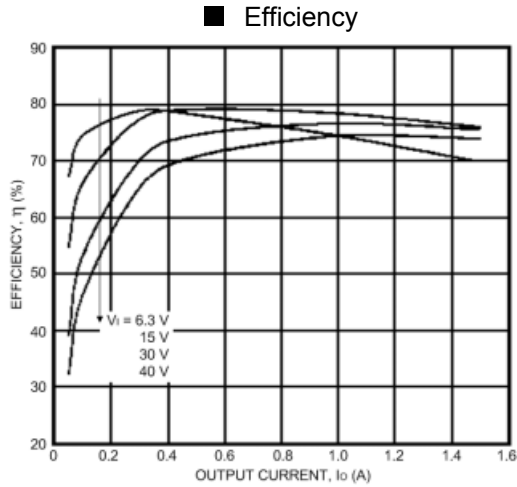

APPLICATIONS INFORMATION

Input Capacitor (C1). Capacitors with low impedance for high-frequency ripple current must be used.

Output Capacitor (C2). Capacitors with low impedance for high-frequency ripple current must be used. Especially when the C2 impedance is high, the switching waveform may not be normal at low temperatures. Film or tantalum capacitor for C2 may cause abnormal oscillations.

Catch Diode (D1). Diode D1 must be a Schottky diode. Other diode types will result in increased forward voltage spikes, reverse current flow, increased IC power dissipation during the off period, and possible destruction of the IC.

Choke Coil (L1). If the winding resistance of the choke coil is too high, the circuit efficiency will decrease. As the overcurrent protection start current is approximately 2.5 A, attention must be paid to the heating of the coil by magnetic saturation due to overload. To reduce the output ripple, the inductor may be increased at the expense of excessive board area and cost.

Soft-Start Capacitor (C3). Soft start for the converter is enabled by connecting a capacitor between terminal 5 and ground. The converter may be turned off by decreasing the terminal 5 voltage below 0.5 V with either an npn small-signal transistor or the output of open-collector TTL. If both a large soft-start capacitor and on/off control are desired, collector current limiting must be used to prevent transistor damage. No external voltage can be applied to terminal 5.

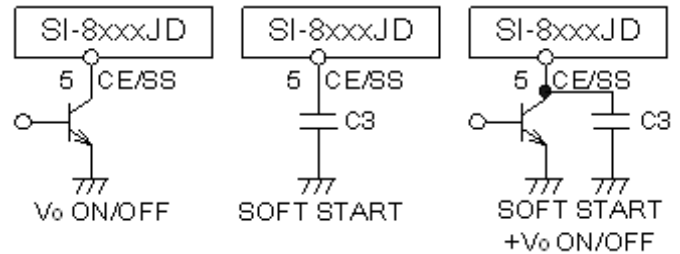

Parallel Operation. Parallel operation to increase load current is not permitted.

Overcurrent Protection. The SI-8000JD series has a built-in fold-back type overcurrent protection circuit, which limits the output current at a start-up mode. It thus cannot be used in applications that require current at the start-up mode such as:

- (1) constant-current load,
- (2) power supply with positive and negative outputs to common load (a center-tap type power supply), or
- (3) raising the output voltage by putting a diode or a resistor between the device ground and system ground.

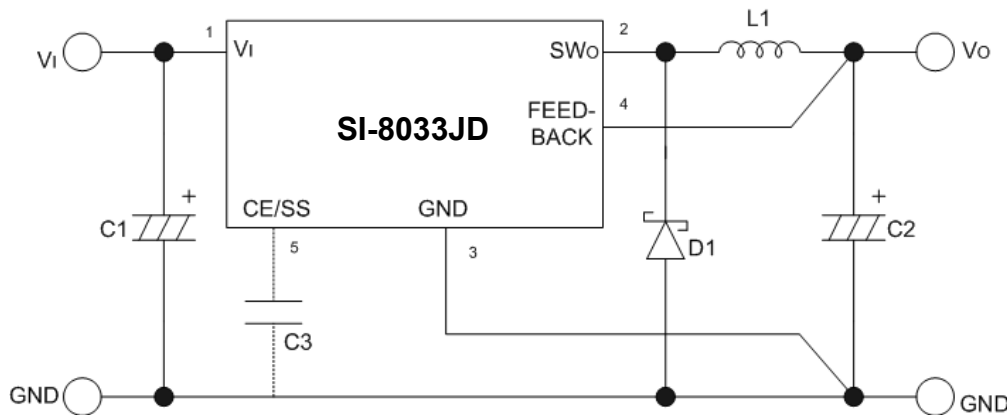

Typical Application

SI-8033JD
Step-Down
to 3.3 V, 1.5 A,
DC/DC Converter

Switching
Regulators

APPLICATIONS INFORMATION (cont.)

Thermal Protection. Circuitry turns off the switching transistor when the junction temperature rises above 150°C. It is intended only to protect the device from failures due to excessive junction temperatures and should not imply that output short circuits or continuous overloads are permitted.

Heat Radiation and Reliability. The reliability of the IC is directly related to the junction temperature (T_J) in its operation. Accordingly, careful consideration should be given to heat dissipation.

The inner frame on which the integrated circuit is mounted is connected to the GND terminal (pin 3). Therefore, it is very effective for heat radiation to enlarge the copper area that is connected to the GND terminal. The graph illustrates the effect of the copper area on the junction-to-ambient thermal resistance ($R_{\theta JA}$).

The junction temperature (T_J) can be determined from either of the following equations:

$$T_J = (P_D R_{\theta JA}) + T_A$$

or

$$T_J = (P_D R_{\theta JC}) + T_C$$

where $P_D = V_I I_I - V_O I_O - V_F I_O (1 - [V_O/V_I])$
 or the adjacent graph,
 V_F = the Schottky diode forward voltage, and
 $R_{\theta JC} = 3^\circ\text{C/W}$.

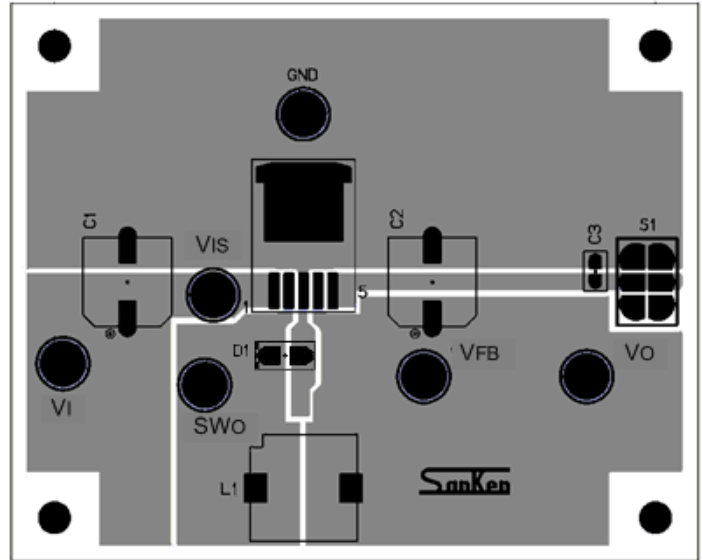

Layout Guideline

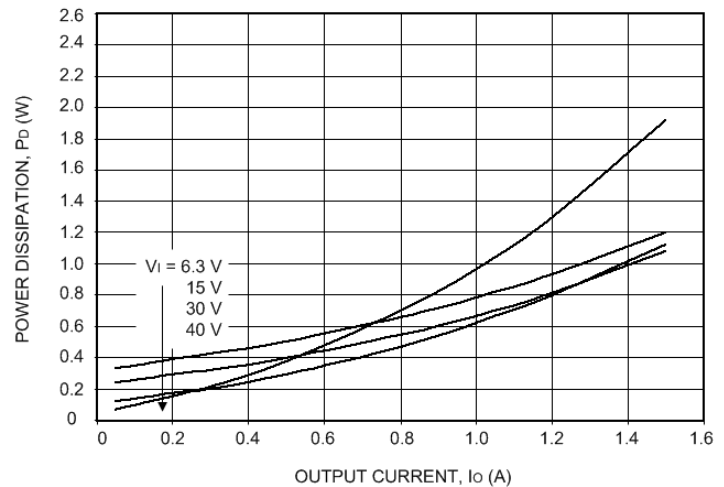
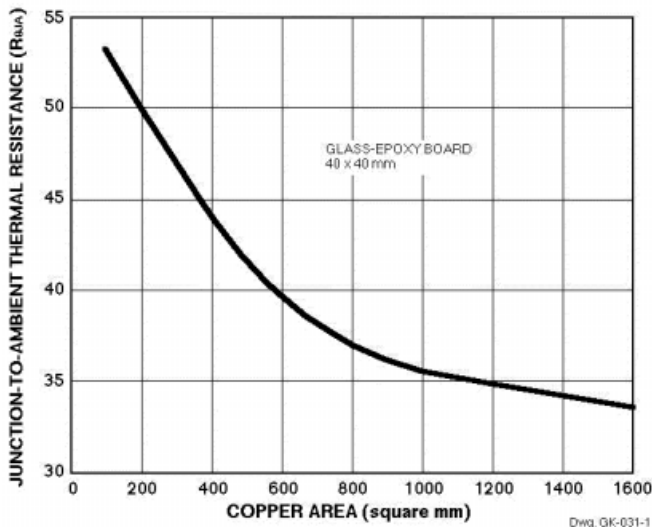

Dimensions in Millimeters

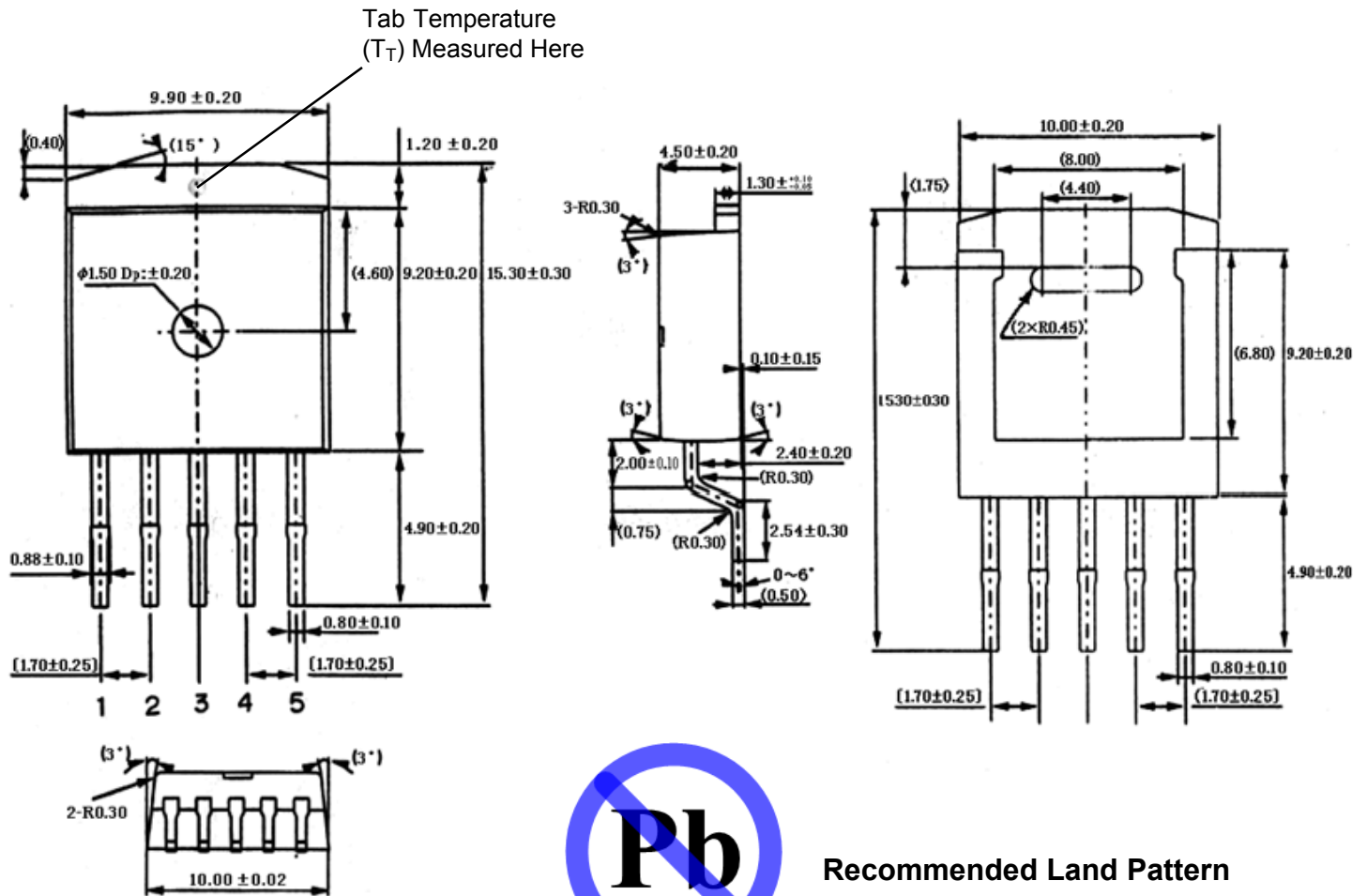

Recommended Land Pattern

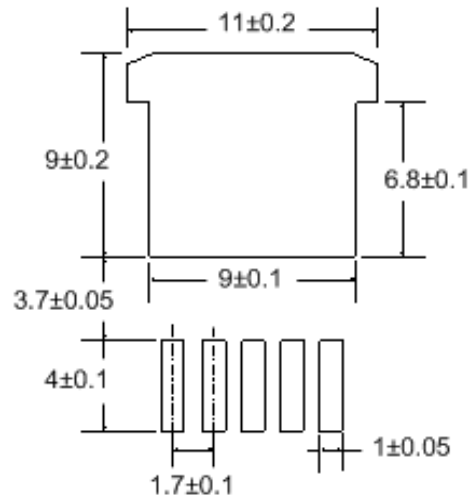

Notes:

1. Dimensions do not include mold protrusions.
2. () Is reference.
3. [] Is assembly out quality.
4. Heat sink side flash: 0.8 mm max.
5. Terminal finish: pure Sn, 2nd level interconnect category (e3)
6. Product weight: approximately 1.48 g

SI-8033JD
Step-Down
to 3.3 V, 1.5 A,
DC/DC Converter

Switching
Regulators

-
- The contents in this document are subject to changes, for improvement and other purposes, without notice. Make sure that this is the latest revision of the document before use.
 - Application and operation examples described in this document are quoted for the sole purpose of reference for the use of the products herein and Sanken can assume no responsibility for any infringement of industrial property rights, intellectual property rights or any other rights of Sanken or any third party which may result from its use.
 - Although Sanken undertakes to enhance the quality and reliability of its products, the occurrence of failure and defect of semiconductor products at a certain rate is inevitable. Users of Sanken products are requested to take, at their own risk, preventative measures including safety design of the equipment or systems against any possible injury, death, fires or damages to the society due to device failure or malfunction.
 - Sanken products listed in this document are designed and intended for the use as components in general purpose electronic equipment or apparatus (home appliances, office equipment, telecommunication equipment, measuring equipment, etc.).

When considering the use of Sanken products in the applications where higher reliability is required (transportation equipment and its control systems, traffic signal control systems or equipment, fire/crime alarm systems, various safety devices, etc.), and whenever long life expectancy is required even in general purpose electronic equipment or apparatus, please contact your nearest Sanken sales representative to discuss, prior to the use of the products herein.

The use of Sanken products without the written consent of Sanken in the applications where extremely high reliability is required (aerospace equipment, nuclear power control systems, life support systems, etc.) is strictly prohibited.

- In the case that you use Sanken products or design your products by using Sanken products, the reliability largely depends on the degree of derating to be made to the rated values. Derating may be interpreted as a case that an operation range is set by derating the load from each rated value or surge voltage or noise is considered for derating in order to assure or improve the reliability. In general, derating factors include electric stresses such as electric voltage, electric current, electric power etc., environmental stresses such as ambient temperature, humidity etc. and thermal stress caused due to self-heating of semiconductor products. For these stresses, instantaneous values, maximum values and minimum values must be taken into consideration.

In addition, it should be noted that since power devices or IC's including power devices have large self-heating value, the degree of derating of junction temperature affects the reliability significantly.

- When using the products specified herein by either (i) combining other products or materials therewith or (ii) physically, chemically or otherwise processing or treating the products, please duly consider all possible risks that may result from all such uses in advance and proceed therewith at your own responsibility.
- Anti radioactive ray design is not considered for the products listed herein.
- Sanken assumes no responsibility for any troubles, such as dropping products caused during transportation out of Sanken's distribution network.
- The contents in this document must not be transcribed or copied without Sanken's written consent.