

DC-to-DC Step-Down Converter

Features and Benefits

- 3.5 A output current supplied in a small, through-hole mount power package
- High efficiency: 83% at $V_{IN}=15\text{ V}$, $I_O=2.0\text{ A}$, $V_O=5\text{ V}$
- Requires only six external components (optional soft start requires an additional capacitor)
- Oscillation circuit built-in (frequency 300 kHz typical)
- Constant-current mode overcurrent protection circuit and overtemperature protection circuit built-in
- Soft start function built-in (can be implemented as an on/off function; output-off state at low level)
- Low current consumption during output-off state

Package: TO220F-5



Not to scale

Description

The SI-8001FFE DC voltage regulator is a DC-to-DC buck convertor that attains an oscillation frequency of 300 kHz, and has an integrated miniaturized choke coil, allowing it to serve as a small, high efficiency power supply in a compact TO220F package.

The internal switching regulator function provides high efficiency switching regulation without any need for adjustment. The device requires only six external support components. The optional soft start function requires an additional capacitor. Optional on/off control can be performed using a transistor. The SI-8001FFE includes overcurrent and overtemperature protection circuits.

Applications include:

- DVD recorder
- FPD TV
- Telecommunications equipment
- Office automation equipment, such as printers
- On-board local power supply
- Output voltage regulator for second stage of SMPS (switched mode power supply)

Functional Block Diagram

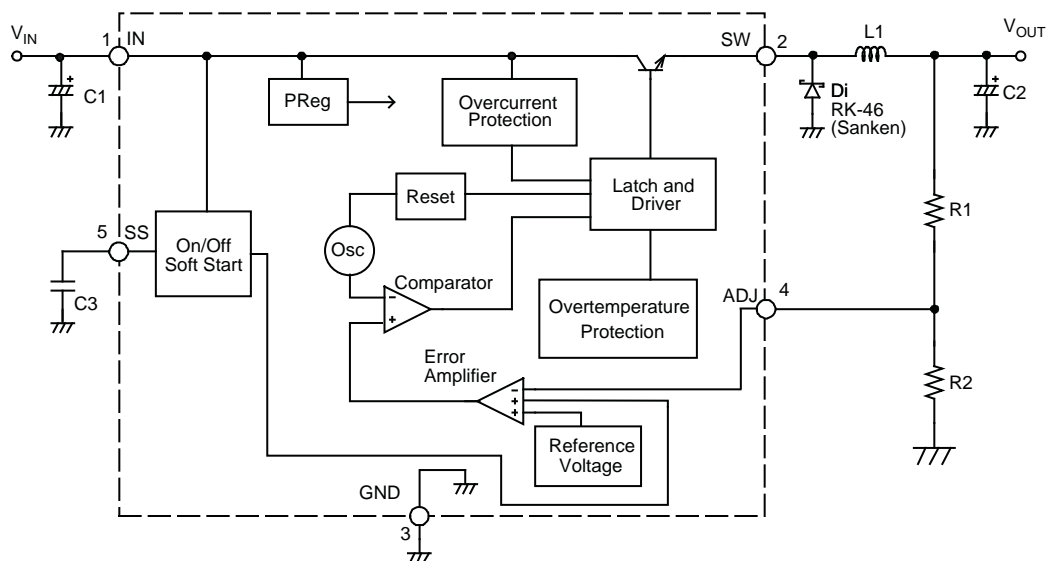

Selection Guide

Part Number	Output Voltage Adjustable Range (V)	Efficiency, Typ. (%)	Input Voltage, Max. (V)	Output Current, Max. (A)	Packing
SI-8001FFE	0.8 to 24	83	40	3.5	50 pieces per tube

Absolute Maximum Ratings

Characteristic	Symbol	Remarks	Rating	Units
DC Input Voltage	V_{IN}		43	V
Power Dissipation	P_{D1-1}	Connected to infinite heatsink; $T_J(\text{max}) = 150^\circ\text{C}$, limited by internal overtemperature protection.	22.7	W
	P_{D1-2}	Connected to infinite heatsink; $T_J = 125^\circ\text{C}$.	18.2	W
	P_{D2-1}	No heatsink; $T_J(\text{max}) = 150^\circ\text{C}$, limited by internal overtemperature protection.	2.15	W
	P_{D2-2}	No heatsink; $T_J = 125^\circ\text{C}$.	1.72	W
Junction Temperature	T_J	Internal overtemperature protection circuit may enable when $T_J \geq 130^\circ\text{C}$. During product operation, recommended $T_J \leq 125^\circ\text{C}$.	-40 to 150	$^\circ\text{C}$
Storage Temperature	T_{stg}		-40 to 150	$^\circ\text{C}$
Thermal Resistance (junction-to-case)	$R_{\theta JC}$		5.5	$^\circ\text{C}/\text{W}$
Thermal Resistance (junction-to-ambient air)	$R_{\theta JA}$		58	$^\circ\text{C}/\text{W}$

Recommended Operating Conditions*

Characteristic	Symbol	Remarks	Min.	Max.	Units
DC Input Voltage Range	V_{IN}	$V_{IN}(\text{min})$ is the greater of 4.5 V or $V_O + 3$ V.	See remarks	40	V
DC Output Voltage Range	V_O		0.8	24	V
DC Output Current Range	I_O	$V_{IN} \geq V_O + 3$ V; to be used within the allowable package power dissipation characteristics (refer to Power Dissipation chart).	0	3.5	A
Operating Junction Temperature Range	T_{JOP}		-30	125	$^\circ\text{C}$
Operating Temperature Range	T_{OP}	To be used within the allowable package power dissipation characteristics (refer to Power Dissipation chart).	-30	85	$^\circ\text{C}$

*Required for normal device functioning according to Electrical Characteristics table.

All performance characteristics given are typical values for circuit or system baseline design only and are at the nominal operating voltage and an ambient temperature, T_A , of 25°C , unless otherwise stated.

ELECTRICAL CHARACTERISTICS¹, valid at T_A = 25°C, V_O = 5 V (adjusted), R₁ = 4.2 kΩ, R₁ = 0.8 kΩ

Characteristic	Symbol	Test Conditions	Min.	Typ.	Max.	Units
Reference Voltage	V _{ADJ}	V _{IN} = 15 V, I _O = 0.2 A	0.784	0.800	0.816	V
Reference Voltage Temperature Coefficient	ΔV _{ADJ} /ΔT	V _{IN} = 15 V, I _O = 0.2 A, T _C = 0 to 100 °C	–	±0.1	–	mV/°C
Efficiency ²	η	V _{IN} = 15 V, I _O = 2 A	–	83	–	%
Operating Frequency	f _O	V _{IN} = 15 V, I _O = 2 A	270	300	330	kHz
Line Regulation	V _{Line}	V _{IN} = 10 to 30 V, I _O = 2 A	–	–	80	mV
Load Regulation	V _{Load}	V _{IN} = 15 V, I _O = 0.2 to 3.5 A	–	–	50	mV
Overcurrent Protection Threshold Current	I _S	V _{IN} = 15 V	3.6	–	–	A
SS Terminal On/Off Operation Threshold Voltage	V _{SSL}		–	–	0.5	V
SS Terminal On/Off Operation Outflow Current	I _{SSL}	V _{SSL} = 0 V	–	6	30	μA
Quiescent Current 1	I _q	V _{IN} = 15 V, I _O = 0 A	–	6	–	mA
Quiescent Current 2	I _{q(off)}	V _{IN} = 15 V, V _{SS} = 0 V	–	200	600	μA

¹Using circuit shown in Typical Application Circuit diagram.

²Efficiency is calculated as: η(%) = (V_O × I_O) / (V_{IN} × I_{IN}) × 100.

Pin-out Diagram

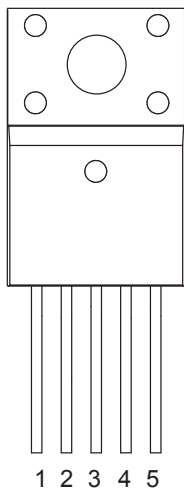

Terminal List Table

Name	Number	Function
IN	1	Supply voltage
SW	2	Regulated supply output
GND	3	Ground terminal
ADJ	4	Terminal for resistor bridge feedback
SS	5	<p>The SS terminal is used to enable soft start and to control on/off operation of the IC output, V_O (see figure 2). If neither soft start nor on/off control is used, leave pin open.</p> <p>To enable soft start, connect a capacitor between SS and ground. To control on/off operation, connect an NPN bipolar transistor, in a TTL open collector output configuration, between the SS terminal and GND. Turn off is done by decreasing V_{SSL} below its rated level.</p> <p>When both soft start and V_O on/off are used, a protection measure such as current limiting is required because, if the capacitance of C3 large, the discharge current of C3 flows across the transistor for on/off operation. Because a pull-up type resistor is provided inside the IC, no external voltage can be applied.</p>

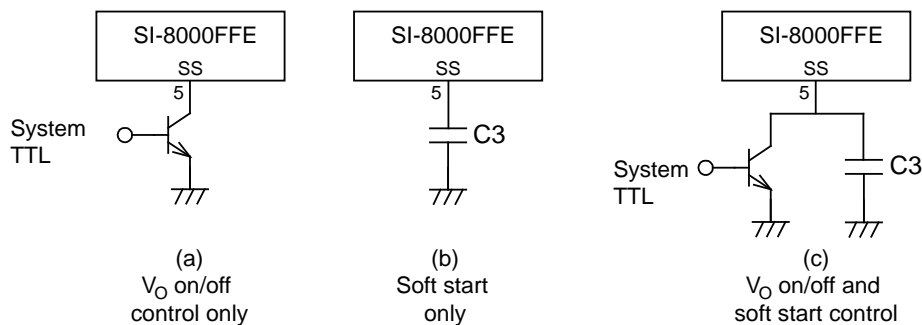
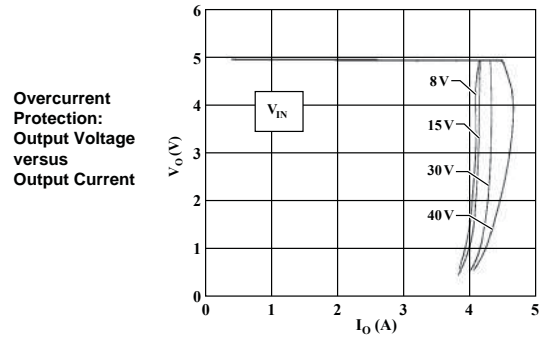
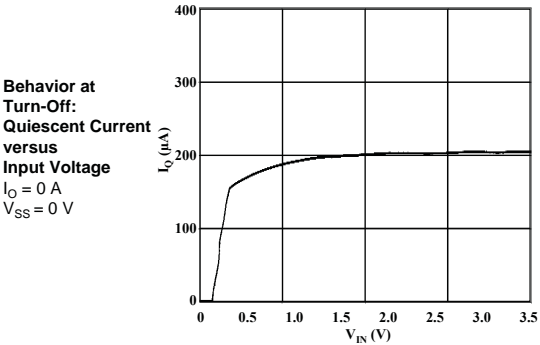
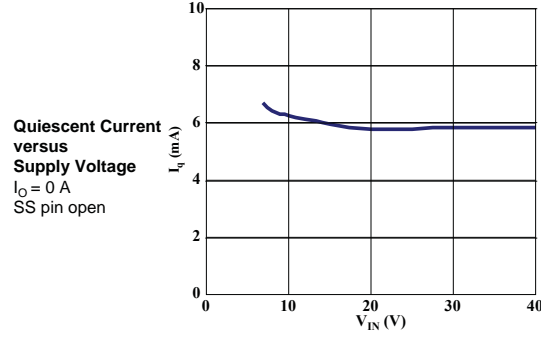
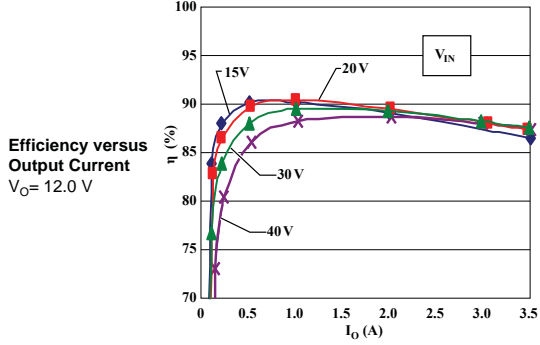
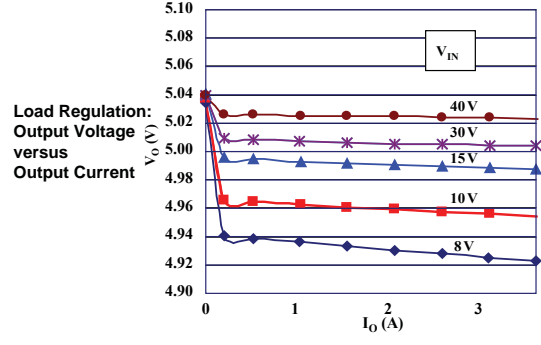
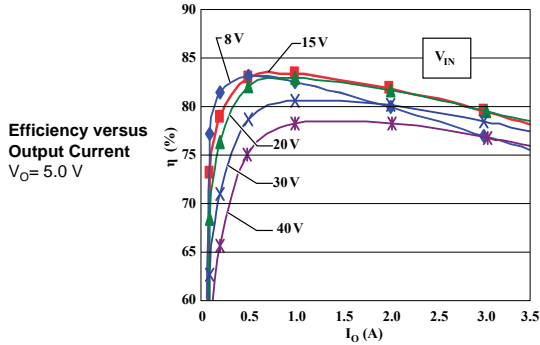
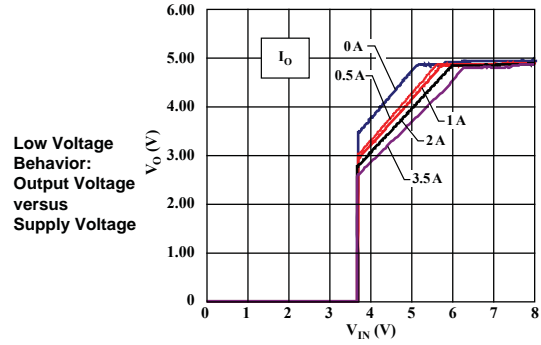
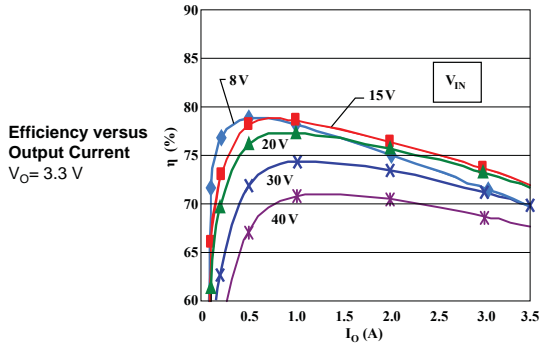

Figure 2. Alternative configurations for SS pin. If neither soft start nor V_O on/off is required, the SS pin is left open.

Performance Characteristics

At $T_A = 25^\circ\text{C}$, $V_O = 5\text{ V}$ Adjusted, $R_1 = 4.2\text{ k}\Omega$, $R_2 = 0.8\text{ k}\Omega$



Thermal Performance Characteristics

The application must be designed to ensure that the $T_J(\text{max})$ of the device is not exceeded during operation. To do so, it is necessary to determine values for maximum power dissipation, $P_D(\text{max})$, and ambient temperature, $T_A(\text{max})$.

P_D can be calculated from input values:

$$P_D = V_O \cdot I_O \left(\frac{100}{\eta_x} - 1 \right) - V_F \cdot I_O \left(1 - \frac{V_O}{V_{IN}} \right)$$

where:

V_O is output voltage in V,

V_{IN} is input supply voltage in V,

I_O is output current in A,

η_x is IC efficiency in percent (varies with V_{IN} and I_O ; refer to efficiency performance curves for value), and

V_F is forward voltage for the input diode, Di. In these tests, the Sanken RK46 was used, at 0.5 V and $I_O = 3.5$ A. For application design, obtain thermal data from the datasheet for the diode.

P_D is substantially affected by the heat conductance properties of the application, in particular any heatsink connected to the device radiation fin. The relationships of P_D , T_A , and heatsink type is represented in the Power Dissipation chart.

Because the heat dissipation capacity of the heatsink depends substantially on how it is used in the actual application, thermal characteristics of the application must be confirmed by testing.

The internal overtemperature protection circuit may enable when $T_J \geq 130^\circ\text{C}$.

Power Dissipation versus Ambient Temperature
Shin Etsu G746 silicon grease

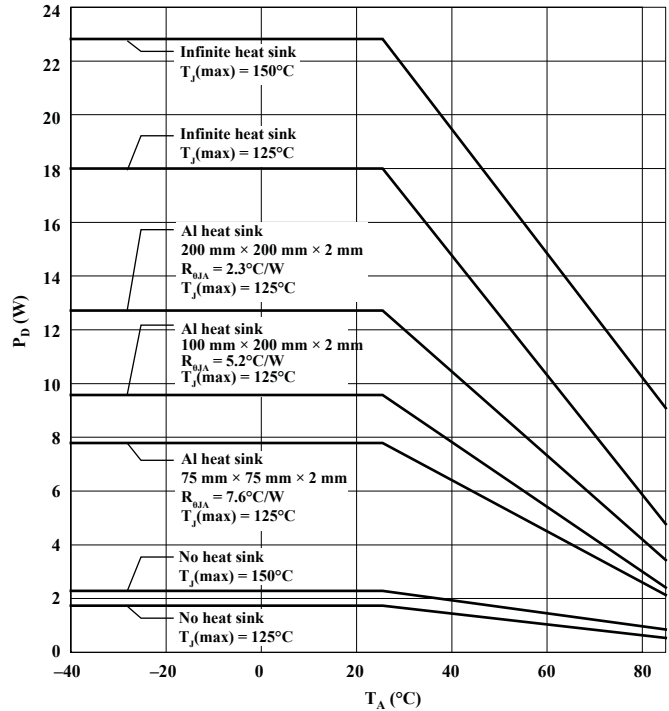

Overtemperature Protection: Output Voltage versus Junction Temperature
 $V_{IN} = 15$ V, $I_O = 10$ mA

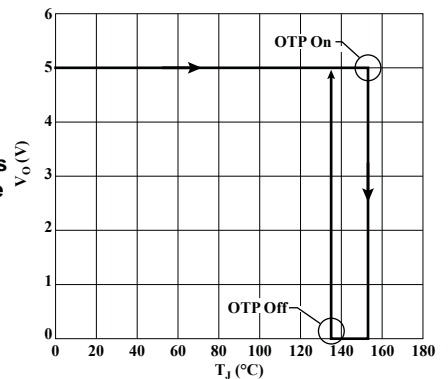

Component Selection

Diode Di A Schottky-barrier diode must be used for Di. If other diode types are used, such as fast recovery diodes, the IC may be destroyed because of the reverse voltage applied by the recovery voltage or ON voltage.

Choke Coil L1 If the winding resistance of the choke coil is too high, the efficiency may be reduced below rating. Because the overcurrent protection start current is approximately 4.2 A, attention must be paid to the heating of the choke coil by magnetic saturation due to overload or short-circuited load.

Capacitors C1, C2, and C3 Because for SMPS, large ripple currents flow across C1 and C2, capacitors with high frequency and low impedance must be used. If the impedance of C2 is too high, the switching waveform may not be normal at low tempera-

tures. Do not use either OS or tantalum types of capacitors for C2, because those cause an abnormal oscillation.

C3 is required only if the soft start function is used. If not using soft-start, leave the SS terminal open. A pull-up resistor is provided inside the IC.

Resistor Bridge R1 and R2 R1 and R2 comprise the resistor bridge for the output voltage, V_O , and are calculated as follows:

$$R1 = \frac{(V_O - V_{ADJ})}{I_{ADJ}} = \frac{(V_O - 0.8)}{1 \times 10^{-3}} (\Omega), \text{ and } R2 = \frac{V_{ADJ}}{I_{ADJ}} = \frac{0.8}{1 \times 10^{-3}} = 0.8 (\text{k}\Omega)$$

I_{ADJ} should always be set to 1 mA. Note that R2 should always be present to ensure stable operation, even if V_O is set to 0.8 V (that is, even if there is no R1). V_O should be at least $V_{IN} + 8\%$.

Typical Application Diagram

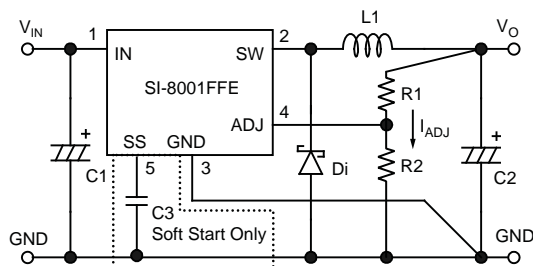

Component	Rating
C1	470 μ F
C2	680 μ F
C3	0.1 μ F (For soft start function)
Di	RK-46 (Sanken)
L1	47 μ H

Recommended PCB Layout

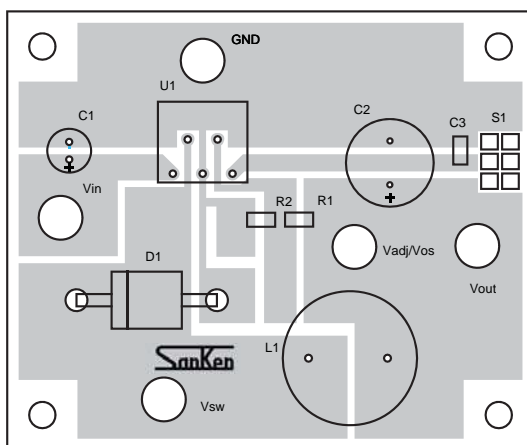

All external components should be mounted as close as possible to the SI-8001FFE. The ground of all components should be connected at one point.

PACKAGE OUTLINE DRAWING

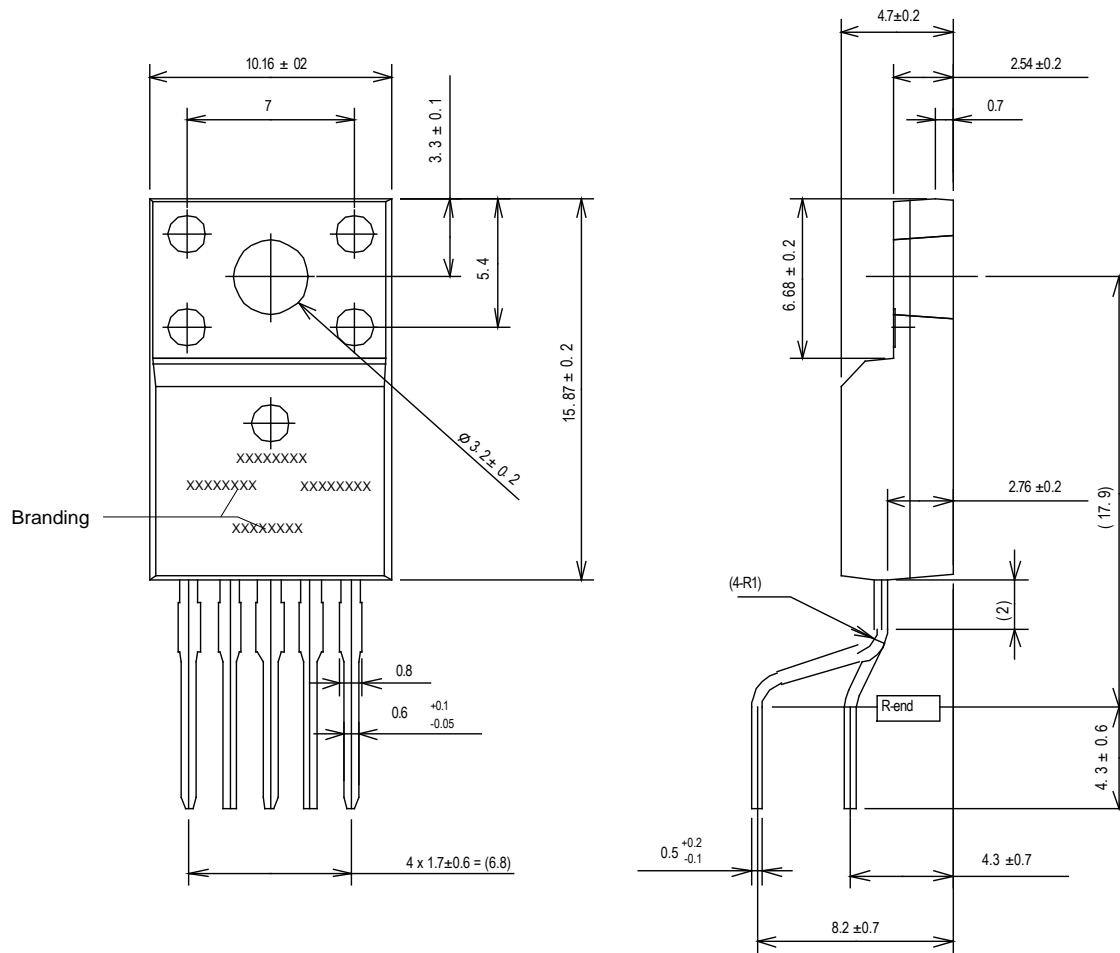

Leadframe: 1113A

Leadform: 1113A
Weight: 2.3 g typical

Dimensions in millimeters

Branding codes (exact appearance at manufacturer discretion):

1st line, type: 8001FFE
2nd line, lot: SK YMW
Where: Y is the last digit of the year of manufacture
M is the month (1 to 9, O, N, D)
W is the week of the month (1 to 5)
3rd line, tracking number: nnnn



RoHS directive compliant
Device pins lead (Pb) free

Because reliability can be affected adversely by improper storage environments and handling methods, please observe the following cautions.

Cautions for Storage

- Ensure that storage conditions comply with the standard temperature (5°C to 35°C) and the standard relative humidity (around 40% to 75%); avoid storage locations that experience extreme changes in temperature or humidity.
- Avoid locations where dust or harmful gases are present and avoid direct sunlight.
- Reinspect for rust on leads and solderability of the products that have been stored for a long time.

Cautions for Testing and Handling

When tests are carried out during inspection testing and other standard test periods, protect the products from power surges from the testing device, shorts between the product pins, and wrong connections. Ensure all test parameters are within the ratings specified by Sanken for the products.

Remarks About Using Silicone Grease with a Heatsink

- When silicone grease is used in mounting the products on a heatsink, it shall be applied evenly and thinly. If more silicone grease than required is applied, it may produce excess stress.
- Volatile-type silicone greases may crack after long periods of time, resulting in reduced heat radiation effect. Silicone greases with low consistency (hard grease) may cause cracks in the mold resin when screwing the products to a heatsink.

Our recommended silicone greases for heat radiation purposes, which will not cause any adverse effect on the product life, are indicated below:

Type	Suppliers
G746	Shin-Etsu Chemical Co., Ltd.
YG6260	Momentive Performance Materials Inc.
SC102	Dow Corning Toray Co., Ltd.

Cautions for Mounting to a Heatsink

- When the flatness around the screw hole is insufficient, such as when mounting the products to a heatsink that has an extruded (burred) screw hole, the products can be damaged, even with a lower than recommended screw torque. For mounting the products, the mounting surface flatness should be 0.05 mm or less.

- Please select suitable screws for the product shape. Do not use a flat-head machine screw because of the stress to the products. Self-tapping screws are not recommended. When using self-tapping screws, the screw may enter the hole diagonally, not vertically, depending on the conditions of hole before threading or the work situation. That may stress the products and may cause failures.
 - Recommended screw torque: 0.588 to 0.785 N•m (6 to 8 kgf•cm).
 - For tightening screws, if a tightening tool (such as a driver) hits the products, the package may crack, and internal stress fractures may occur, which shorten the lifetime of the electrical elements and can cause catastrophic failure. Tightening with an air driver makes a substantial impact. In addition, a screw torque higher than the set torque can be applied and the package may be damaged. Therefore, an electric driver is recommended.
- When the package is tightened at two or more places, first pre-tighten with a lower torque at all places, then tighten with the specified torque. When using a power driver, torque control is mandatory.

Soldering

- When soldering the products, please be sure to minimize the working time, within the following limits:
260±5°C 10±1 s (Flow, 2 times)
380±10°C 3.5±0.5 s (Soldering iron, 1 time)
- Soldering should be at a distance of at least 2.0 mm from the body of the products.

Electrostatic Discharge

- When handling the products, the operator must be grounded. Grounded wrist straps worn should have at least 1 MΩ of resistance from the operator to ground to prevent shock hazard, and it should be placed near the operator.
- Workbenches where the products are handled should be grounded and be provided with conductive table and floor mats.
- When using measuring equipment such as a curve tracer, the equipment should be grounded.
- When soldering the products, the head of soldering irons or the solder bath must be grounded in order to prevent leak voltages generated by them from being applied to the products.
- The products should always be stored and transported in Sanken shipping containers or conductive containers, or be wrapped in aluminum foil.

-
- The contents in this document are subject to changes, for improvement and other purposes, without notice. Make sure that this is the latest revision of the document before use.
 - Application and operation examples described in this document are quoted for the sole purpose of reference for the use of the products herein and Sanken can assume no responsibility for any infringement of industrial property rights, intellectual property rights or any other rights of Sanken or any third party which may result from its use.
 - Although Sanken undertakes to enhance the quality and reliability of its products, the occurrence of failure and defect of semiconductor products at a certain rate is inevitable. Users of Sanken products are requested to take, at their own risk, preventative measures including safety design of the equipment or systems against any possible injury, death, fires or damages to the society due to device failure or malfunction.
 - Sanken products listed in this document are designed and intended for the use as components in general purpose electronic equipment or apparatus (home appliances, office equipment, telecommunication equipment, measuring equipment, etc.).

When considering the use of Sanken products in the applications where higher reliability is required (transportation equipment and its control systems, traffic signal control systems or equipment, fire/crime alarm systems, various safety devices, etc.), and whenever long life expectancy is required even in general purpose electronic equipment or apparatus, please contact your nearest Sanken sales representative to discuss, prior to the use of the products herein.

The use of Sanken products without the written consent of Sanken in the applications where extremely high reliability is required (aerospace equipment, nuclear power control systems, life support systems, etc.) is strictly prohibited.

- In the case that you use Sanken products or design your products by using Sanken products, the reliability largely depends on the degree of derating to be made to the rated values. Derating may be interpreted as a case that an operation range is set by derating the load from each rated value or surge voltage or noise is considered for derating in order to assure or improve the reliability. In general, derating factors include electric stresses such as electric voltage, electric current, electric power etc., environmental stresses such as ambient temperature, humidity etc. and thermal stress caused due to self-heating of semiconductor products. For these stresses, instantaneous values, maximum values and minimum values must be taken into consideration.

In addition, it should be noted that since power devices or IC's including power devices have large self-heating value, the degree of derating of junction temperature affects the reliability significantly.

- When using the products specified herein by either (i) combining other products or materials therewith or (ii) physically, chemically or otherwise processing or treating the products, please duly consider all possible risks that may result from all such uses in advance and proceed therewith at your own responsibility.
- Anti radioactive ray design is not considered for the products listed herein.
- Sanken assumes no responsibility for any troubles, such as dropping products caused during transportation out of Sanken's distribution network.
- The contents in this document must not be transcribed or copied without Sanken's written consent.