

## High-Current, Low-Dropout, 3.3 V Regulator

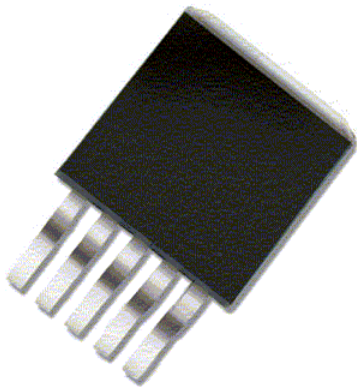
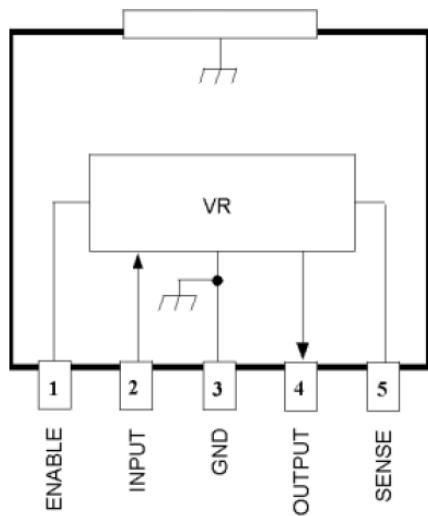

### ABSOLUTE MAXIMUM RATINGS

Input Voltage, $V_I$ .....	10 V
Output Current, $I_O$ .....	3 A*
Enable Input Voltage, $V_E$ .....	6 V
Junction Temperature, $T_J$ .....	+125°C
Storage Temperature Range, $T_S$ .....	-40°C to +125°C

\* Output current rating is limited by input voltage, duty cycle, and ambient temperature. Under any set of conditions, do not exceed a junction temperature of +125°C.

Designed to meet the high-current requirements in industrial and consumer applications; embedded core, memory, or logic supplies; TVs, VCRs, and office equipment, the SI-3033ZD voltage regulator offers the reduced dropout voltage and low quiescent current essential for improved efficiency. This device delivers a regulated output at up to 3 A. Integrated thermal and overcurrent protection enhance overall system reliability. Devices with an adjustable 1.2 ~ 5 V output or a 2.5 V fixed output are also available.

Quiescent current does not increase significantly as the dropout voltage is approached, an ideal feature in standby/resume power systems where data integrity is crucial. Regulator accuracy and excellent temperature characteristics are provided by a bandgap reference. An LS-TTL/CMOS-compatible input gives the designer complete control over power up, standby, or power down. A pnp pass element provides a dropout voltage of less than 600 mV at 3 A of load current. Low output voltages eliminate the need for expensive PWM buck converters. The low dropout voltage permits more efficient regulation before output regulation is lost.

This device is supplied in a 5-lead surface-mount plastic package (TO-263) with ground tab to provide a low-resistance path for maximum heat dissipation. A similar device in a flange-mounted (TO-220-style) high-power package is the SI-3025ZF.

### FEATURES

- 3 A Output Current at 3.3 V
- 0.6 V Maximum Dropout Voltage at  $I_O = 3$  A
- 1  $\mu$ A Maximum Standby Current
- Remote Voltage Sensing
- Foldback Current Limiting
- Ground Tab for Superior Heat Dissipation
- Thermal Protection

### APPLICATIONS

- TVs, VCRs, Electronic Games
- Embedded Core, Memory, or Logic Supplies
- Printers and Other Office Equipment
- Industrial Machinery
- Secondary-Side Stabilization of Multi-Output SMPS

Always order by complete part number, e.g., **SI-3033ZD-TL**, where "-TL" indicates tape and reel.

**SI-3033ZD**  
**High-Current,**  
**Low-Dropout,**  
**3.3 V Regulator**

*Linear  
Regulators*

**FUNCTIONAL BLOCK DIAGRAM**

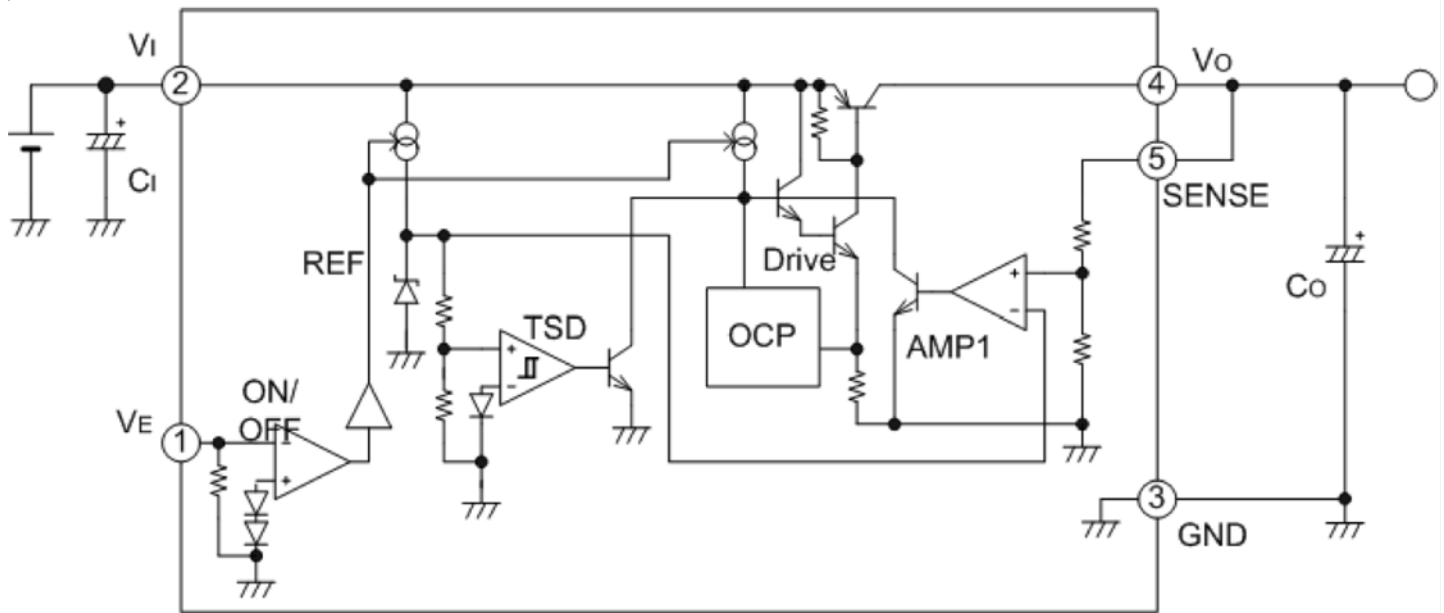

**Allowable Package Power Dissipation**

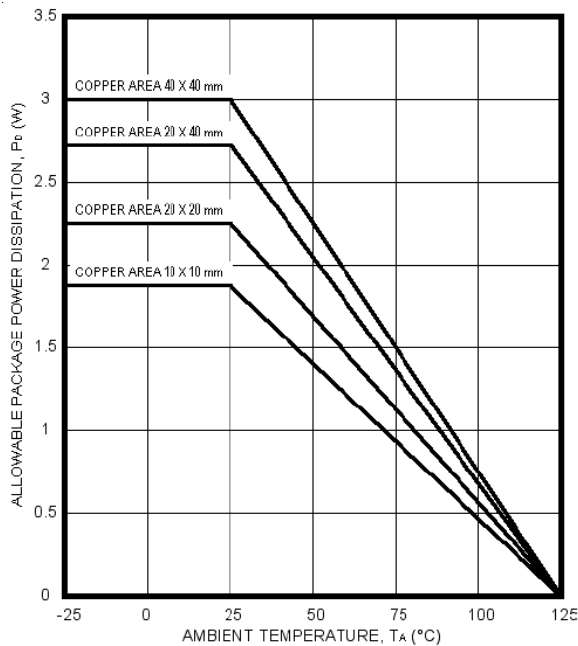

Dwg. GK-003-7A

**Recommended Operating Conditions**

	Min	Max	Units
DC Input Voltage	—	6	V
DC Output Current	0	3	A
Operating Junction Temp.	-20	+100	°C

For the availability of parts meeting -40°C requirements, contact Sanken's Sales Representative.

This data sheet is based on Sanken data sheet SSJ-02590

**ELECTRICAL CHARACTERISTICS** at  $T_A = +25^\circ\text{C}$ ,  $V_E = 2\text{ V}$  (unless otherwise noted).

Characteristic	Symbol	Test Conditions	Limits			
			Min.	Typ.	Max.	Units
Output Voltage	$V_O$	$V_I = 5\text{ V}$ , $I_O = 10\text{ mA}$	3.234	3.300	3.366	V
	$V_{O(\text{off})}$	$V_E = 0\text{ V}$	—	—	0.5	V
Output Volt. Temp. Coeff.	$a_{VO}$	$0^\circ\text{C} \leq T_J \leq 100^\circ\text{C}$	—	$\pm 0.3$	—	mV/°C
Output Short-Circuit Current	$I_{OM}$	$V_I = 5\text{ V}$ , see note	3.2	—	—	A
Line Regulation	$\Delta V_{O(\Delta V_I)}$	$V_I = 4.5 \sim 5.5\text{ V}$ , $I_O = 10\text{ mA}$	—	—	10	mV
Load Regulation	$\Delta V_{O(\Delta I_O)}$	$V_I = 5\text{ V}$ , $I_O = 0\text{ A} \sim 3.0\text{ A}$	—	—	40	mV
Dropout Voltage	$V_{\text{Imin}} - V_O$	$I_O = 3.0\text{ A}$	—	—	0.6	V
Ground Terminal Current	$I_{\text{GND}}$	$V_I = 5\text{ V}$ , $I_O = 0\text{ mA}$ , $V_E = 2.0\text{ V}$	—	1.0	1.5	mA
		$V_I = 5\text{ V}$ , $V_E = 0\text{ V}$	—	—	1.0	$\mu\text{A}$
Enable Input Voltage	$V_{\text{EH}}$	Output ON	2.0	—	—	V
	$V_{\text{EL}}$	Output OFF	—	—	0.8	V
Enable Input Current	$I_{\text{EH}}$	$V_E = 2.7\text{ V}$	—	—	100	$\mu\text{A}$
	$I_{\text{EL}}$	$V_E = 0\text{ V}$	—	0	-5.0	$\mu\text{A}$
Ripple Rejection Ratio	PSRR	$V_I = 5\text{ V}$ , $100\text{ Hz} \leq f \leq 120\text{ Hz}$	—	60	—	dB
Thermal Shutdown	$T_J$		135	152	—	°C

Typical values are given for circuit design information only.

Note: Output short-circuit current is at point where output voltage has decreased 5% below  $V_{O(\text{nom})}$ .

**SI-3033ZD**  
**High-Current,**  
**Low-Dropout,**  
**3.3 V Regulator**

*Linear  
Regulators*

**TYPICAL CHARACTERISTICS**

( $T_A = 25^\circ\text{C}$ )

■ Dropout Voltage

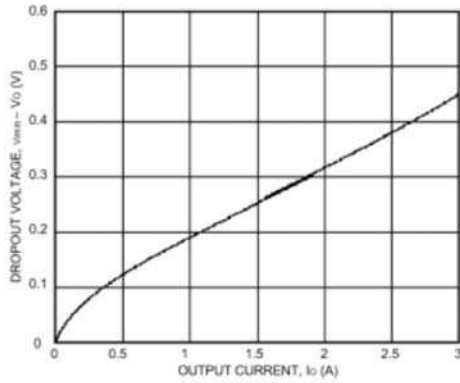

■ Low-Voltage Behavior

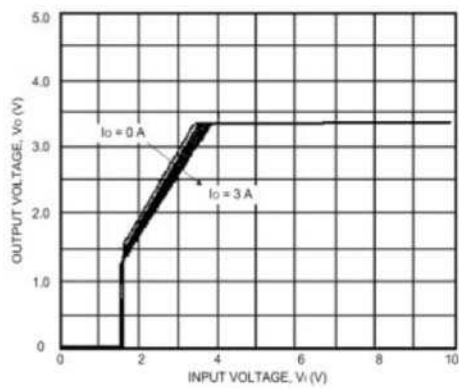

■ GND Pin Current

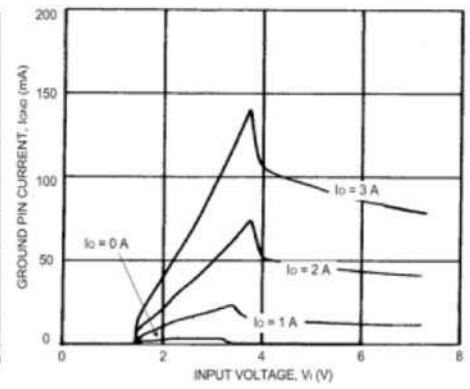

■ Line Regulation

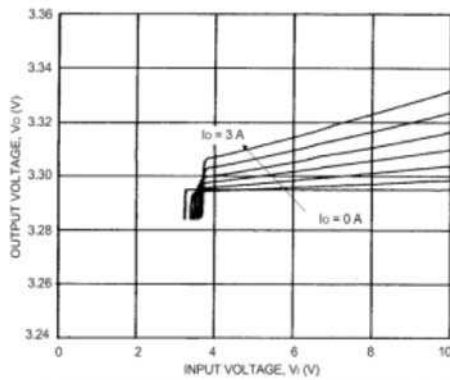

■ Load Regulation

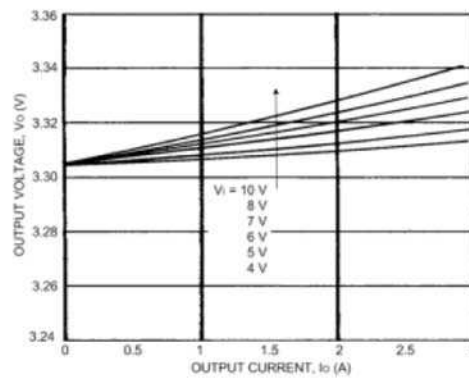

■ Overcurrent Protection

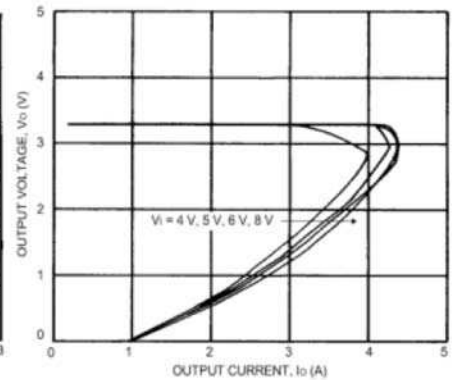

■ ENABLE Control Voltage

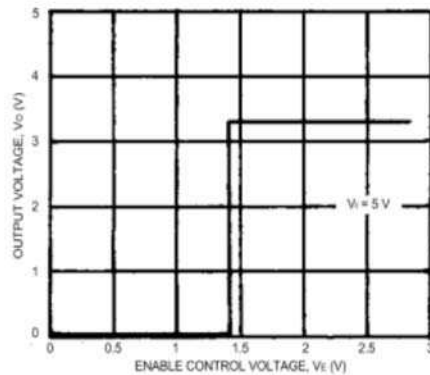

■ ENABLE Control Current

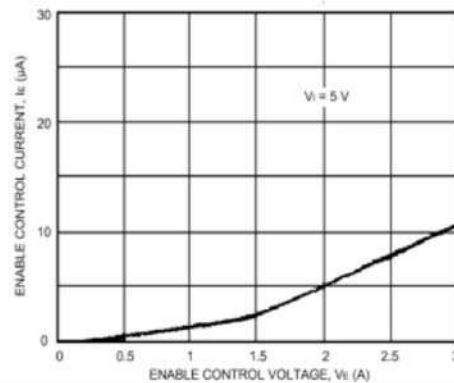

■ Thermal Protection

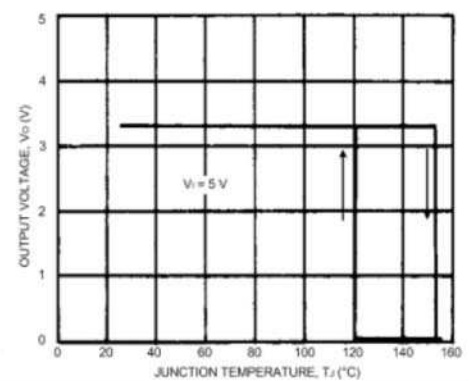

## APPLICATIONS INFORMATION

**Input Capacitor** ( $C_I$ , 0.1  $\mu\text{F}$  to 10  $\mu\text{F}$ ). This is necessary either when the input line includes inductance or when the wiring is long.

**Output Capacitor** ( $C_O$ , > 47  $\mu\text{F}$ ). This device is not designed for a use with a very low ESR output capacitor such as a ceramic capacitor. Output oscillation may occur with that kind of capacitor.

**Determination of DC Input Voltage.** The minimum input voltage  $V_I(\text{min})$  should be higher than the sum of the fixed output voltage and the maximum rated dropout voltage.

**Increased Output Voltage.** The output voltage ( $V_O$ ) may be increased by inserting a resistor ( $R_{\text{EXT}}$ ) between SENSE and OUTPUT. The current flowing into SENSE is typically 90  $\mu\text{A} \pm 30\%$ . To minimize the effect of  $I_{\text{SENSE}}$  and temperature on  $R_{\text{EXT}}$ , it is recommended that a 9.1 k $\Omega$  resistor be added between SENSE and GND to increase the current in  $R_{\text{EXT}}$ . The value of  $R_{\text{EXT}}$  is then

$$R_{\text{EXT}} = (V_O - 3.3) \times 10^6 / 453$$

**Overcurrent Protection.** The SI-3000ZD series has a built-in fold-back type overcurrent protection circuit, which limits the output current at a start-up mode. It thus cannot be used in applications that require current at the start-up mode such as:

- (1) constant-current load,
- (2) power supply with positive and negative outputs to common load (a center-tap type power supply), or
- (3) raising the output voltage by putting a diode or a resistor between the device ground and system ground.

**Thermal Protection.** Circuitry turns off the pass transistor when the junction temperature rises above 135°C. It is intended only to protect the device from failures due to excessive junction temperatures and should not imply that output short circuits or continuous overloads are permitted.

**Heat Radiation and Reliability.** The reliability of the IC is directly related to the junction temperature ( $T_J$ ) in its operation. Accordingly, careful consideration should be given to heat dissipation.

The inner frame on which the integrated circuit is mounted is connected to the GND terminal (pin 3). Therefore, it is very effective for heat radiation to enlarge the copper area that is connected to the GND terminal. The graph illustrates the effect of the copper area on the junction-to-ambient thermal resistance ( $R_{\theta JA}$ ).

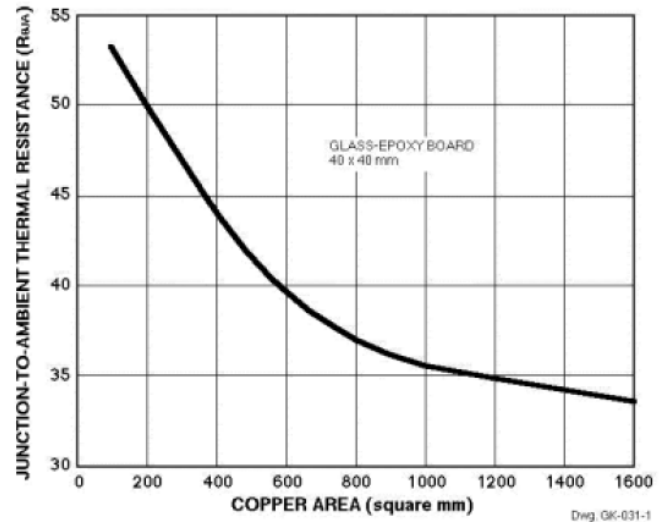

The junction temperature ( $T_J$ ) can be determined from either of the following equations:

$$T_J = (P_D \times R_{\theta JA}) + T_A$$

or

$$T_J = (P_D \times R_{\theta JT}) + T_T$$

where  $P_D = I_O \times (V_I - V_O)$  and  $R_{\theta JT} = 3^\circ\text{C/W}$ .

**Parallel Operation.** Parallel operation to increase load current is not permitted.

**SI-3033ZD**  
**High-Current,**  
**Low-Dropout,**  
**3.3 V Regulator**

*Linear  
Regulators*

**Dimensions in Millimeters**

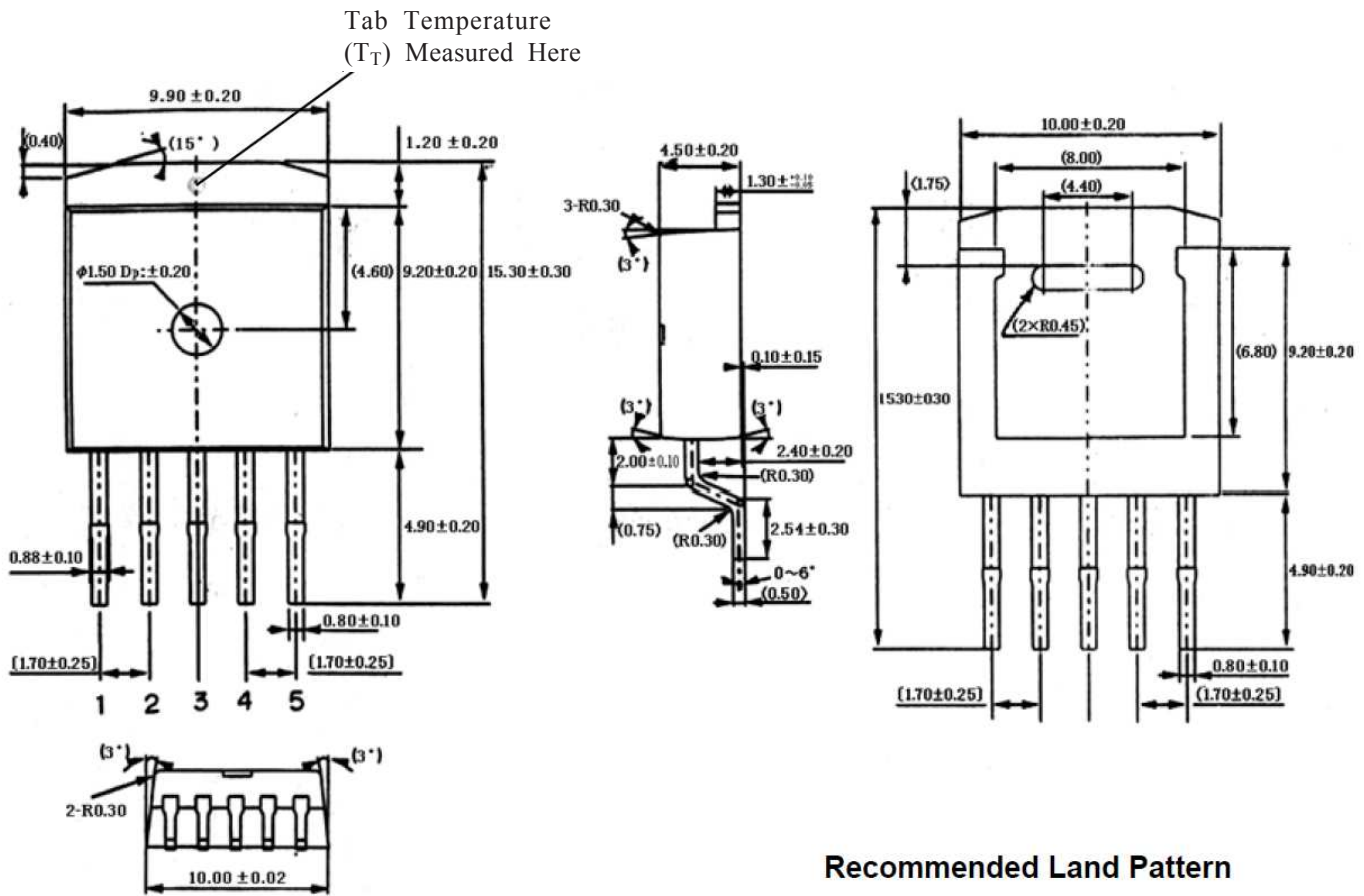

**Recommended Land Pattern**

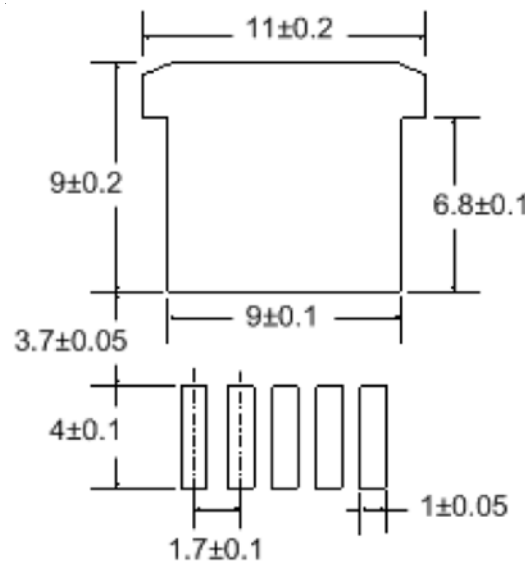

**Notes:**

1. Dimensions do not include mold protrusions.
2. ( ) Is reference.
3. [ ] Is assembly out quality.
4. Heat sink side flash: 0.8 mm max.
5. Terminal finish: pure Sn, 2<sup>nd</sup> level interconnect category (e3)
6. Product weight: approximately 1.48 g

- The contents in this document are subject to changes, for improvement and other purposes, without notice. Make sure that this is the latest revision of the document before use.
- Application and operation examples described in this document are quoted for the sole purpose of reference for the use of the products herein and Sanken can assume no responsibility for any infringement of industrial property rights, intellectual property rights or any other rights of Sanken or any third party which may result from its use.
- Although Sanken undertakes to enhance the quality and reliability of its products, the occurrence of failure and defect of semiconductor products at a certain rate is inevitable. Users of Sanken products are requested to take, at their own risk, preventative measures including safety design of the equipment or systems against any possible injury, death, fires or damages to the society due to device failure or malfunction.

- Sanken products listed in this document are designed and intended for the use as components in general purpose electronic equipment or apparatus (home appliances, office equipment, telecommunication equipment, measuring equipment, etc.).

When considering the use of Sanken products in the applications where higher reliability is required (transportation equipment and its control systems, traffic signal control systems or equipment, fire/crime alarm systems, various safety devices, etc.), and whenever long life expectancy is required even in general purpose electronic equipment or apparatus, please contact your nearest Sanken sales representative to discuss, prior to the use of the products herein.

The use of Sanken products without the written consent of Sanken in the applications where extremely high reliability is required (aerospace equipment, nuclear power control systems, life support systems, etc.) is strictly prohibited.

- In the case that you use Sanken products or design your products by using Sanken products, the reliability largely depends on the degree of derating to be made to the rated values. Derating may be interpreted as a case that an operation range is set by derating the load from each rated value or surge voltage or noise is considered for derating in order to assure or improve the reliability. In general, derating factors include electric stresses such as electric voltage, electric current, electric power etc., environmental stresses such as ambient temperature, humidity etc. and thermal stress caused due to self-heating of semiconductor products. For these stresses, instantaneous values, maximum values and minimum values must be taken into consideration.

In addition, it should be noted that since power devices or IC's including power devices have large self-heating value, the degree of derating of junction temperature affects the reliability significantly.

- When using the products specified herein by either (i) combining other products or materials therewith or (ii) physically, chemically or otherwise processing or treating the products, please duly consider all possible risks that may result from all such uses in advance and proceed therewith at your own responsibility.
- Anti radioactive ray design is not considered for the products listed herein.
- Sanken assumes no responsibility for any troubles, such as dropping products caused during transportation out of Sanken's distribution network.
- The contents in this document must not be transcribed or copied without Sanken's written consent.