

High Voltage 3-Phase Motor Driver

Features and Benefits

- Each half-bridge circuit consists of a pre-driver circuit that is completely independent from the others
- Protection against simultaneous high- and low-side turning on
- Bootstrap diodes with series resistors for suppressing inrush current are incorporated
- CMOS compatible input (3.3 to 5 V)
- Designed to minimize simultaneous current through both high- and low-side IGBTs by optimizing gate drive resistors
- Integrated Fast Recovery Diode (FRD) as freewheeling diode for each IGBT
- UVLO protection with auto restart
- Overcurrent protection with off-time period adjustable by an external capacitor
- Fault (FO indicator) signal output at protection activation: UVLO (low side only), OCP, and STP
- Proprietary power DIP package
- UL Recognized Component (File No.: E118037)

Package: Power DIP

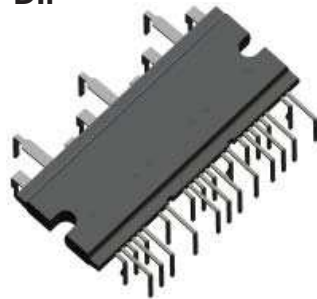

Not to scale

Description

The SCM1106M inverter power module (IPM) device provides a robust, highly-integrated solution for optimally controlling 3-phase motor power inverter systems and variable speed control systems used in energy-conserving designs to drive motors of residential and commercial appliances. These ICs take 85 to 253 VAC input voltage, and 10 A (continuous) output current. They can withstand voltages of up to 600 V (IGBT breakdown voltage).

The SCM1100M series employs a new, small-footprint proprietary DIP package. The IC itself consists of all of the necessary power elements (six IGBTs), pre-drive ICs (three), and freewheeling diodes (six), needed to configure the main circuit of an inverter, as well as a bootstrap circuit (three bootstrap diodes and three boot resistors) as a high-side drive power supply. This enables the main circuit of the inverter to be configured with fewer external components than traditional designs.

Applications include residential white goods (home appliances) and commercial appliance motor control, such as:

- Air conditioner fan motor
- Refrigerator compressor motor
- Washing machine main motor
- Air conditioner compressor motor

Functional Block Diagram

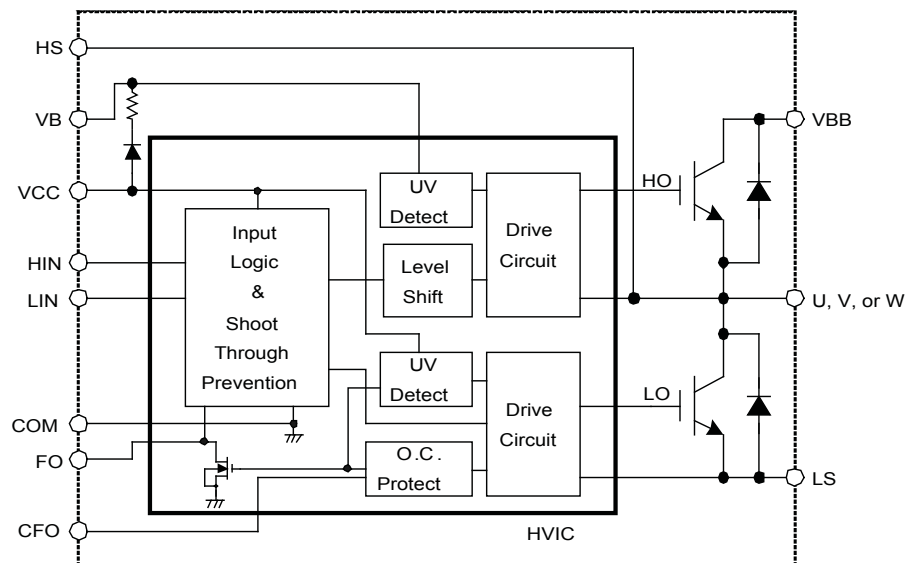

Figure 1. Diagram of one of three phases in the device.

Selection Guide

Part Number	Packing	IGBT Breakdown Voltage, $V_{CES(min)}$ (V)	IGBT Saturation Voltage, $V_{CE(sat)(typ)}$ (V)	Output Current	
				Continuous, $I_O(max)$ (A)	Pulsed, $I_{OP}(max)$ (A)
SCM1106M	10 pieces per tube	600	2.2	10	20

Absolute Maximum Ratings, valid at $T_A = 25^\circ\text{C}$

Characteristic	Symbol	Remarks	Rating	Units
Supply Voltage	V_{DC}	Between VBB and LS1, LS2, and LS3	450	V
Supply Voltage (Surge)	$V_{DC(surge)}$	Between VBB and LS1, LS2, and LS3	500	V
IGBT Breakdown Voltage	V_{CES}	$V_{CC} = 15\text{ V}$, $I_C = 1\text{ mA}$, $V_{IN} = 0\text{ V}$	600	V
Logic Supply Voltage	V_{CC}	Between VCC and COM	20	V
Boot-strap Voltage	V_{BS}	Between VB and HS (U,V,W)	20	V
Output Current, Continuous	I_O	$T_{Case} = 25^\circ\text{C}$	10	Adc
		$T_{Case} = 100^\circ\text{C}$	5.2	Adc
Output Current, Pulsed	I_{OP}	Pulse Width $\leq 1\text{ ms}$	20	A
Input Voltage	V_{IN}		-0.5 to 7	V
FO Terminal Voltage	V_{FO}	Between FO and COM	7	V
Maximum Allowable Power Dissipation	P_D	$T_{Case} = 25^\circ\text{C}$, 1 element operation (IGBT)	20.8	W
		$T_{Case} = 100^\circ\text{C}$, 1 element operation (IGBT)	8.3	W
Thermal Resistance, Junction-to-Case	$R_{(j-c)Q}$	1 element operation (IGBT)	6.0	$^\circ\text{C/W}$
	$R_{(j-c)F}$	1 element operation (FRD)	6.5	$^\circ\text{C/W}$
Case Operation Temperature	T_{COP}		-20 to 100	$^\circ\text{C}$
Junction Temperature (IGBT)	T_J		150	$^\circ\text{C}$
Storage Temperature	T_{stg}		-40 to 150	$^\circ\text{C}$
Isolation Voltage	V_{iso}	Between exposed thermal pad and each pin; 1 minute, AC	2000	V_{rms}

Recommended Operating Conditions

Characteristic	Symbol	Remarks	Min.	Typ.	Max.	Units
Main Supply Voltage	V_{DC}	Between VBB and LS	-	300	400	V
Logic Supply Voltage	V_{CC}	Between VCC and COM	13.5	-	16.5	V
Logic Supply Voltage	V_{BS}	Between VB and HS	13.5	-	16.5	V
Minimum Input Pulse Width	$t_{INmin(on)}$	On pulse	0.5	-	-	μs
	$t_{INmin(off)}$	Off pulse	0.5	-	-	μs
Dead Time	t_{dead}		1.5	-	-	μs
FO Pull-up Resistor	R_{FO}		1	-	22	$\text{k}\Omega$
CFO Capacitor	C_{FO}		1	-	10	nF
FO Pull-up Voltage	V_{FO}		4.5	-	5.5	V
Bootstrap Capacitor	C_{BOOT}		10	-	220	μF
Shunt Resistor	R_S	For $I_P \leq 20\text{ A}$	25.5	-	-	$\text{m}\Omega$
PWM Carrier Frequency	f_C		-	-	20	kHz
Junction Temperature	T_J		-	-	125	$^\circ\text{C}$

All performance characteristics given are typical values for circuit or system baseline design only and are at the nominal operating voltage and an ambient temperature, T_A , of 25°C , unless otherwise stated.

Typical Application Diagram

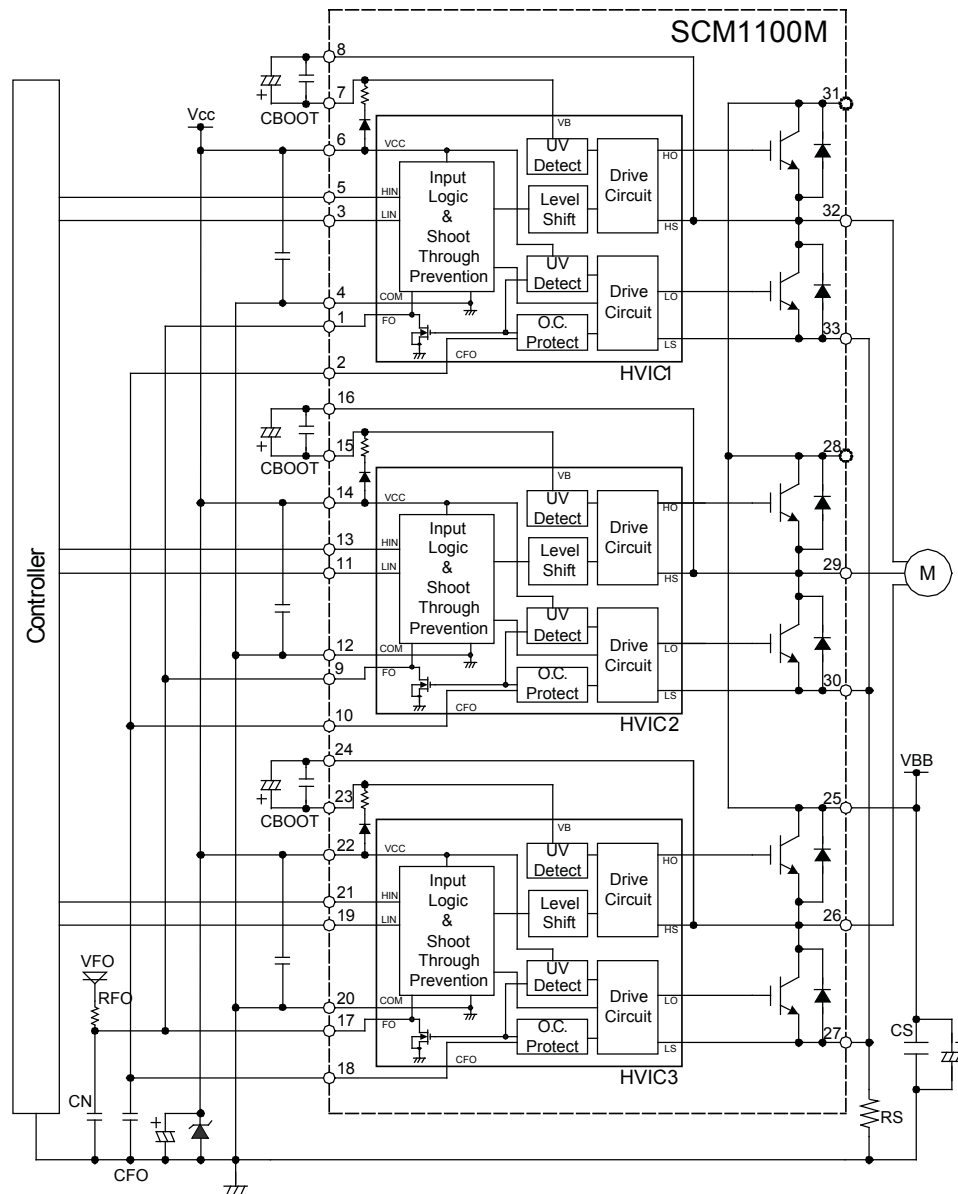

NOTE:

- To use the OCP circuit, an external shunt resistor, RS, is needed. The RS value can be obtained from the formula:

$$R_S(\Omega) = 0.5 (V) / \text{Overcurrent Detection Set Current (A)} - 0.0024 (\Omega)$$
- To avoid malfunction, the wiring between the LS and COM pins should be as short as possible.
- To prevent surge destruction, put a 0.01 to 1 μF snubber capacitor, CS, in parallel with the electrolytic capacitor.
- To prevent surge destruction, put a 18 to 20 V Zener diode between the VCC and COM pins.
- To prevent surge malfunction, put a 0.01 to 0.1 μF ceramic capacitor between the VCC and COM pins and the VB and HS pins.

ELECTRICAL CHARACTERISTICS, valid at $T_A=25^\circ\text{C}$, unless otherwise noted

Characteristics	Symbol	Conditions	Min	Typ	Max	Units
Logic Supply Voltage	V_{CC}	Between VCC and COM	13.5	–	16.5	V
Logic Supply Current	I_{CC}	$V_{CC} = 15\text{ V}$, 3 phases operating	–	5	8	mA
Bootstrap Supply Current	I_{BS}	$V_B - HS = 15\text{ V}$, one phase operating	–	400	800	μA
Input Voltage	V_{IH}	$V_{CC} = 15\text{ V}$, output on	–	2.0	2.5	V
	V_{IL}	$V_{CC} = 15\text{ V}$, output off	1.0	1.5	–	V
Input Voltage Hysteresis	V_{Ihys}	$V_{CC} = 15\text{ V}$	–	0.5	–	V
Input Current	I_{IHH}	$V_{CC} = 15\text{ V}$, $V_{IN} = 5\text{ V}$	–	50	100	μA
	I_{ILH}	$V_{CC} = 15\text{ V}$, $V_{IN} = 0\text{ V}$	–	–	2	μA
Undervoltage Lock Out (High Side)	U_{VHL}	$V_{CC} = 15\text{ V}$	10.0	–	12.0	V
	U_{VHH}		10.5	–	12.5	V
Undervoltage Lock Out (Low Side)	U_{VLL}	$V_{CC} = 15\text{ V}$	10.5	–	12.5	V
	U_{VLH}		11.0	–	13.0	V
FO Terminal Output Voltage	V_{FOL}	$V_{CC} = 15\text{ V}$, $V_{FO} = 5\text{ V}$, $R_{FO} = 10\text{ k}\Omega$	–	–	0.5	V
	V_{FOH}		4.8	–	–	V
Overcurrent Protection Trip Voltage	V_{TRIP}	$V_{CC} = 15\text{ V}$	0.46	0.50	0.54	V
Overcurrent Protection Hold Time	t_P	$V_{CC} = 15\text{ V}$, $C_{FO} = 0.0022\text{ }\mu\text{F}$	2	–	–	ms
Blanking Time	t_{blank}	$V_{CC} = 15\text{ V}$	–	2	–	μs
IGBT Breakdown Voltage	V_{CES}	$V_{CC} = 15\text{ V}$, $I_C = 250\text{ }\mu\text{A}$, $V_{IN} = 0\text{ V}$	600	–	–	V
IGBT Leakage Current	I_{CES}	$V_{CC} = 15\text{ V}$, $V_{CE} = 600\text{ V}$, $V_{IN} = 0\text{ V}$	–	–	1	mA
IGBT Saturation Voltage	$V_{CE(sat)}$	$V_{CC} = 15\text{ V}$, $I_C = 10\text{ A}$, $V_{IN} = 5\text{ V}$	–	2.2	2.6	V
Diode Forward Voltage	V_F	$V_{CC} = 15\text{ V}$, $I_F = 10\text{ A}$, $V_{IN} = 0\text{ V}$	–	1.7	2.2	V
Diode Recovery Time (Bootstrap)	t_{rr}	$I_F / I_{RP} = 100\text{ mA}/100\text{ mA}$	–	70	–	ns
Diode Leakage Current (Boot Strap)	I_{IB}	$V_R = 600\text{ V}$	–	5	10	μA
Diode Forward Voltage (Boot Strap)	V_{FB}	$I_F = 0.15\text{ A}$	–	1.1	1.3	V
Diode Series Resistor (Boot Strap)	R_B		17.6	22.0	26.4	Ω
High Side Switching Time	$t_{dH(on)}$	$V_{DC} = 300\text{ V}$, $V_{CC} = 15\text{ V}$, $I_C = 10\text{ A}$, inductive load; $HIN = 0 \rightarrow 5\text{ V}$ or $5 \rightarrow 0\text{ V}$	–	320	–	ns
	t_{rH}		–	50	–	ns
	t_{rrH}		–	80	–	ns
	$t_{dH(off)}$		–	490	–	ns
	t_{fH}		–	80	–	ns
Low Side Switching Time	$t_{dL(on)}$	$V_{DC} = 300\text{ V}$, $V_{CC} = 15\text{ V}$, $I_C = 10\text{ A}$, inductive load; $LIN = 0 \rightarrow 5\text{ V}$ or $5 \rightarrow 0\text{ V}$	–	350	–	ns
	t_{rL}		–	80	–	ns
	t_{rrL}		–	140	–	ns
	$t_{dL(off)}$		–	540	–	ns
	t_{fL}		–	80	–	ns

Switching Timing Definitions

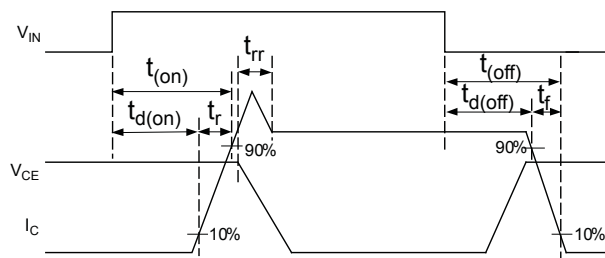

Input Output Truth Table

HIN	LIN	OUT
L	L	High Z
L	H	L
H	L	H
H	H	High Z

High Z = High Impedance

Pin-out Diagram

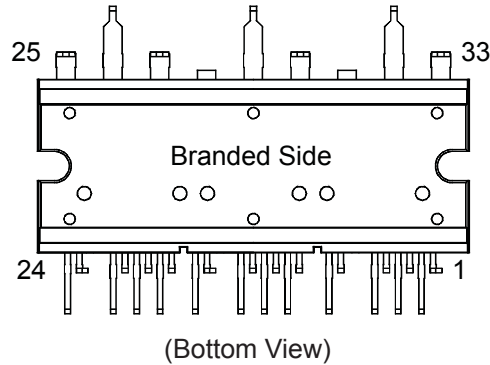

Terminal List Table

Name	Number	Function
1	FO1	U phase fault output for overcurrent and UVLO detected
2	CFO1	Capacitor for U phase overcurrent protection hold time
3	LIN1	Signal input for low-side U phase (active high)
4	COM1	Supply ground for U phase IC
5	HIN1	Signal input for high-side U phase (active high)
6	VCC1	Supply voltage for U phase IC
7	VB1	High-side floating supply voltage for U phase
8	HS1	High-side floating supply ground for U phase
9	FO2	V phase fault output for overcurrent and UVLO detected
10	CFO2	Capacitor for V phase overcurrent protection hold time
11	LIN2	Signal input for low-side V phase (active high)
12	COM2	Supply ground for V phase IC
13	HIN2	Signal input for high-side V phase (active high)
14	VCC2	Supply voltage for V phase IC
15	VB2	High-side floating supply voltage for V phase
16	HS2	High-side floating supply ground for V phase
17	FO3	W phase fault output for overcurrent and UVLO detected
18	CFO3	Capacitor for W phase overcurrent protection hold time
19	LIN3	Signal input for low-side W phase (active high)
20	COM3	Supply ground for W phase IC
21	HIN3	Signal input for high-side W phase (active high)
22	VCC3	Supply voltage for W phase IC
23	VB3	High-side floating supply voltage for W phase
24	HS3	High-side floating supply ground for W phase
25	VBB	Positive DC bus supply voltage
26	W	Output for W phase
27	LS3	Negative DC bus supply ground for W phase
28	VBB	Cut-pin (positive DC bus supply voltage)
29	V	Output for V phase
30	LS2	Negative DC bus supply ground for V phase
31	VBB	Cut-pin (positive DC bus supply voltage)
32	U	Output for U phase
33	LS1	Negative DC bus supply ground for U phase

Timing Diagrams

High-Side Driver Input/Output

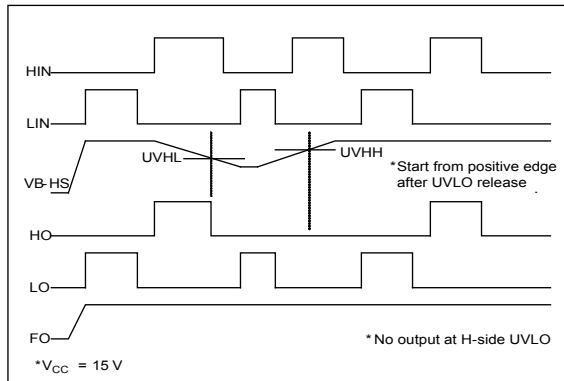

Low-Side Driver Input/Output

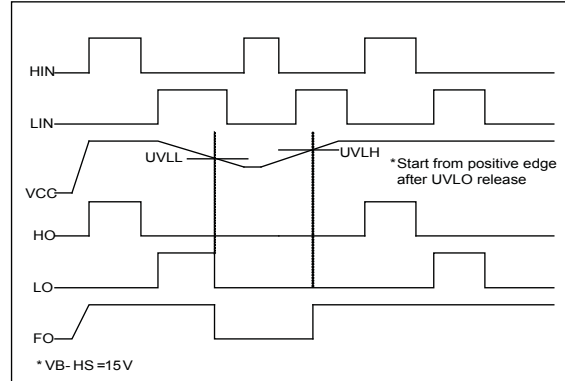

Shoot-Through Prevention

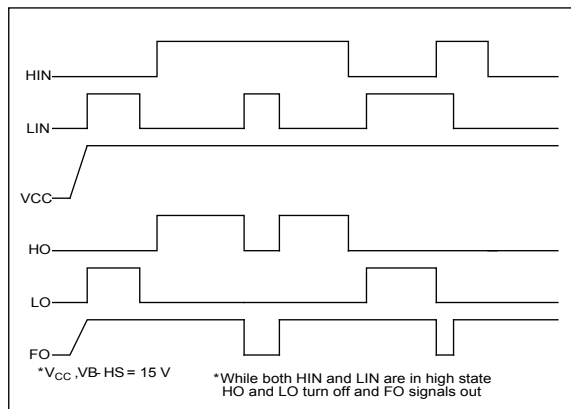

Overcurrent Protection

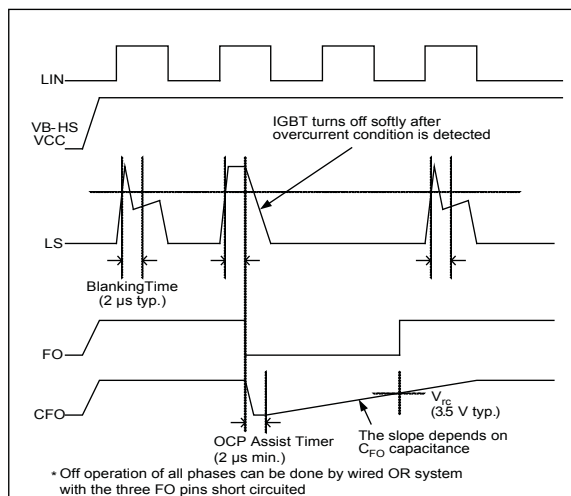

PACKAGE OUTLINE DRAWING

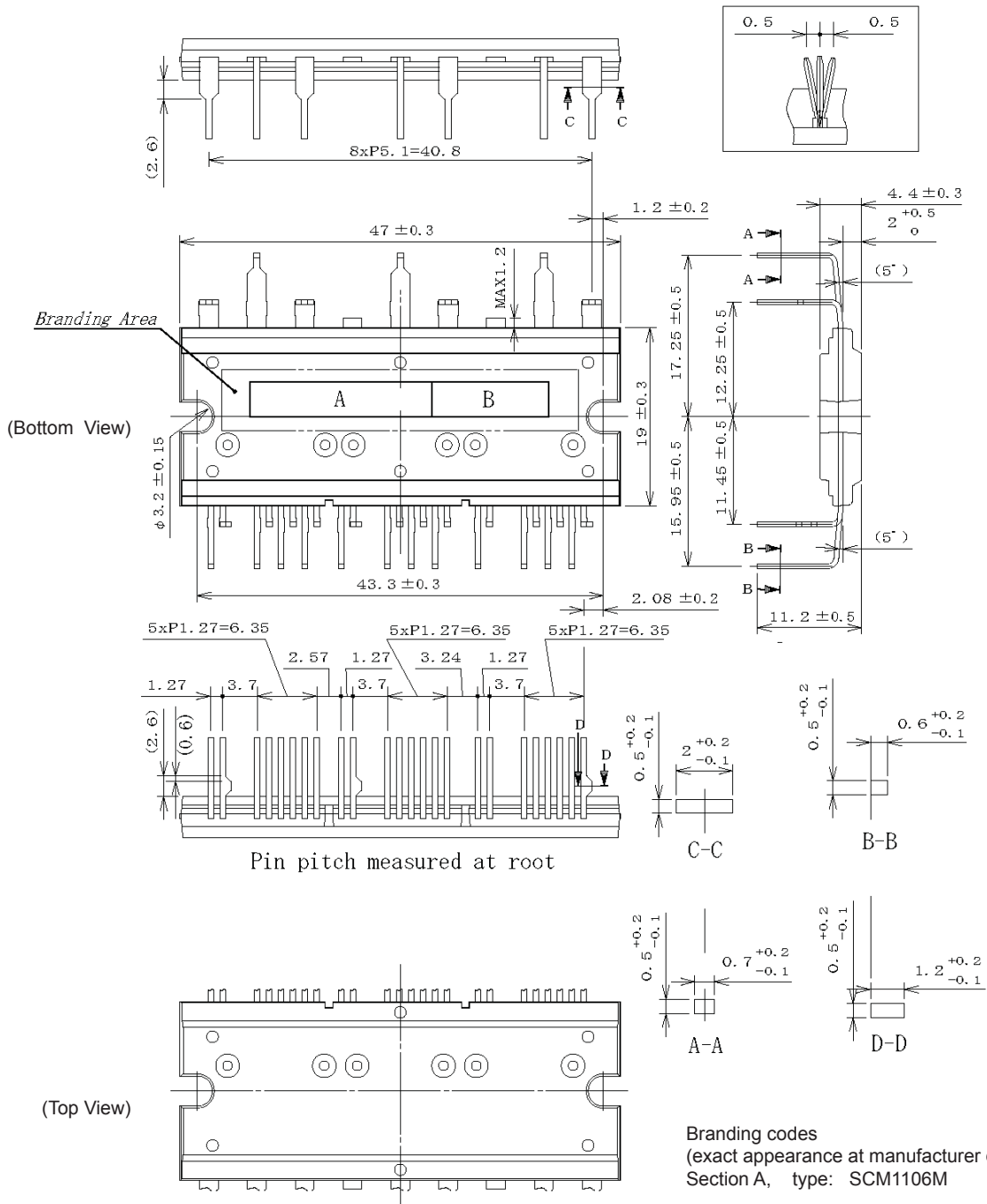

Leadform: 2552
Dimensions in millimeters

Leadframe plating Pb-free. Device composition complies with the RoHS directive.

MECHANICAL CHARACTERISTICS

Characteristic	Remarks	Min.	Typ.	Max.	Units
Heatsink Mounting Screw Torque	Use one M3 screw each end	58.8	–	78.4	N•cm
		6.0	–	8.0	kgf•cm
Flatness of Heatsink Attachment Area	Refer to figure below (aaa)	–50	–	100	μm
Package Weight		–	13.5	–	g

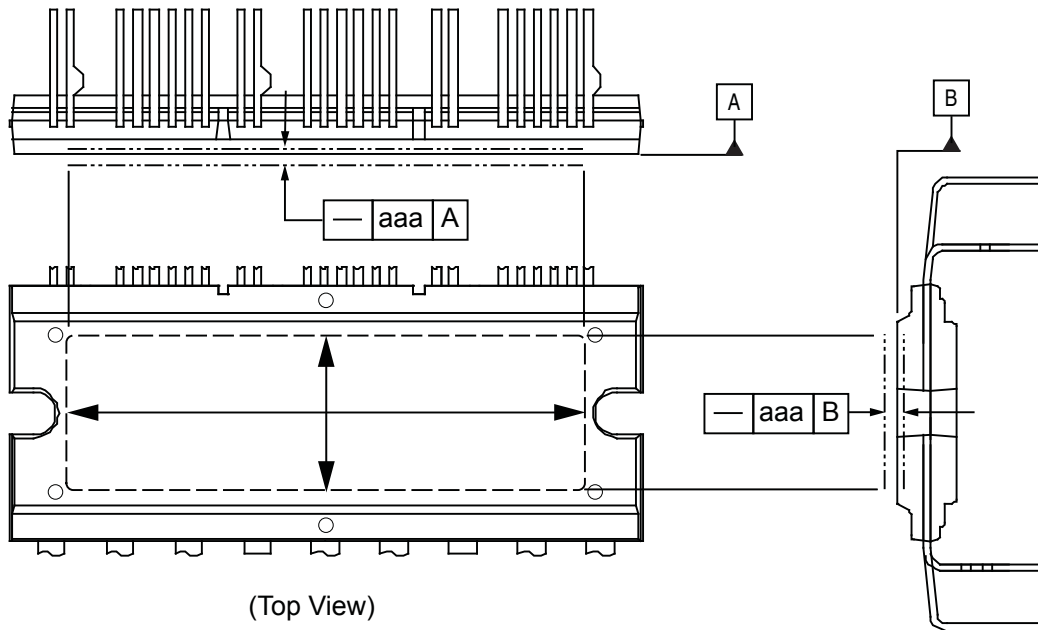

PACKING SPECIFICATION

Dimensions in millimeters

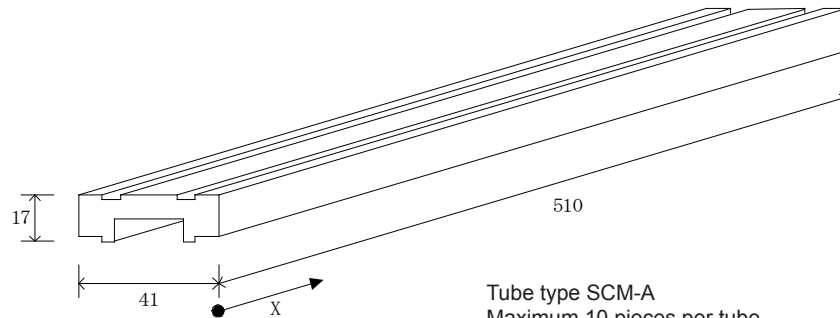

Tube type SCM-A
Maximum 10 pieces per tube
Pins aligned along X direction
Rubber plug at each end

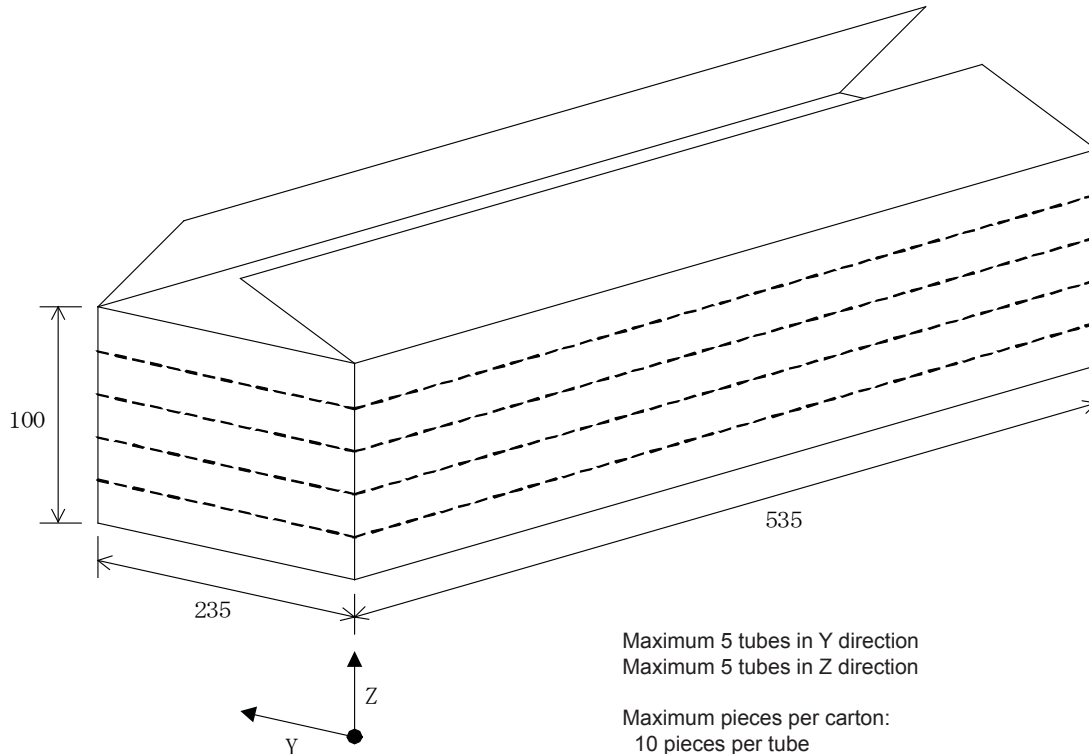

Maximum 5 tubes in Y direction
Maximum 5 tubes in Z direction

Maximum pieces per carton:
10 pieces per tube
5 rows of tubes
x 5 layers of tubes
250 pieces per carton

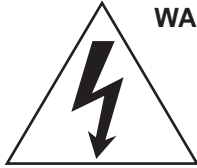

WARNING — These devices are designed to be operated at lethal voltages and energy levels. Circuit designs that embody these components must conform with applicable safety requirements. Precautions must be taken to prevent accidental contact with power-line potentials. Do not connect grounded test equipment.

The use of an isolation transformer is recommended during circuit development and breadboarding.

Because reliability can be affected adversely by improper storage environments and handling methods, please observe the following cautions.

Cautions for Storage

- Ensure that storage conditions comply with the standard temperature (5°C to 35°C) and the standard relative humidity (around 40 to 75%); avoid storage locations that experience extreme changes in temperature or humidity.
- Avoid locations where dust or harmful gases are present and avoid direct sunlight.
- Reinspect for rust on leads and solderability of product that has been stored for a long time.

Cautions for Testing and Handling

When tests are carried out during inspection testing and other standard test periods, protect the product from power surges from the testing device, shorts between adjacent product packages, and shorts to the heatsink.

Remarks About Using Silicone Grease with a Heatsink

- Ensure there are no foreign objects between the heatsink and thermal pad; only silicone thermal grease is allowed.
- When silicone grease is used in mounting this product with a heatsink, grease shall be applied evenly and thinly. If more silicone grease than required is applied, it may produce stress.
- Volatile-type silicone greases may permeate the product and produce cracks after long periods of time, resulting in reduced heat radiation effect, and possibly shortening the lifetime of the product.
- Hard silicone greases may cause cracks in the product when screwing the product to a heatsink.

- Our recommended silicone greases for heat radiation purposes, which will not cause any adverse effect on the product life, are indicated below:

Type	Suppliers
G746	Shin-Etsu Chemical Co., Ltd.
YG6260	Momentive Performance Materials
SC102	Dow Corning Toray Silicone Co., Ltd.

Soldering

- When soldering the product, please be sure to minimize the working time, within the following limits:
260±5°C 10 s
380±5°C 5 s
- Soldering iron should be at a distance of at least 1.5 mm from the body of the product

Electrostatic Discharge

- When handling the product, operator must be grounded. Grounded wrist straps worn should have at least 1 MΩ of resistance to ground to prevent shock hazard.
- Workbenches where the product is handled should be grounded and be provided with conductive table and floor mats.
- When using measuring equipment such as a curve tracer, the equipment should be grounded.
- When soldering the product, the head of soldering irons or the solder bath must be grounded in order to prevent leak voltages generated by them from being applied to the product.
- The product should always be stored and transported in our shipping containers or conductive containers, or be wrapped in aluminum foil.

The products described herein are manufactured in Japan by Sanken Electric Co., Ltd. for sale by Allegro MicroSystems, Inc.

Sanken and Allegro reserve the right to make, from time to time, such departures from the detail specifications as may be required to permit improvements in the performance, reliability, or manufacturability of its products. Therefore, the user is cautioned to verify that the information in this publication is current before placing any order.

When using the products described herein, the applicability and suitability of such products for the intended purpose shall be reviewed at the users responsibility.

Although Sanken undertakes to enhance the quality and reliability of its products, the occurrence of failure and defect of semiconductor products at a certain rate is inevitable.

Users of Sanken products are requested to take, at their own risk, preventative measures including safety design of the equipment or systems against any possible injury, death, fires or damages to society due to device failure or malfunction.

Sanken products listed in this publication are designed and intended for use as components in general-purpose electronic equipment or apparatus (home appliances, office equipment, telecommunication equipment, measuring equipment, etc.). Their use in any application requiring radiation hardness assurance (e.g., aerospace equipment) is not supported.

When considering the use of Sanken products in applications where higher reliability is required (transportation equipment and its control systems or equipment, fire- or burglar-alarm systems, various safety devices, etc.), contact a company sales representative to discuss and obtain written confirmation of your specifications.

The use of Sanken products without the written consent of Sanken in applications where extremely high reliability is required (aerospace equipment, nuclear power-control stations, life-support systems, etc.) is strictly prohibited.

The information included herein is believed to be accurate and reliable. Application and operation examples described in this publication are given for reference only and Sanken and Allegro assume no responsibility for any infringement of industrial property rights, intellectual property rights, or any other rights of Sanken or Allegro or any third party that may result from its use.

Anti radioactive ray design is not considered for the products listed herein.

The contents in this document must not be transcribed or copied without Sanken's written consent.