

## GaAs MMIC PASSIVE FREQUENCY DOUBLER, 10 - 15 GHz INPUT

### Typical Applications

This HMC-XDB112 is ideal for:

- Point-to-Point Radios
- VSAT
- Test Instrumentation
- Military & Space
- Clock Generation

### Features

- Conversion Loss: 13 dB
- Passive: No DC Bias Required
- Input Drive: +13 dBm
- High Fo Isolation: 30 dB
- Die Size: 2.2 x 0.65 x 0.1 mm

### Functional Diagram

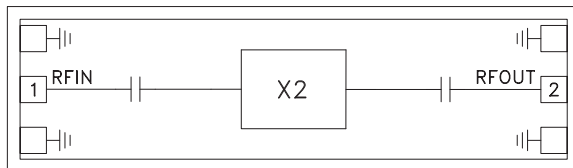

### General Description

The HMC-XDB112 is a monolithic Passive Frequency Doubler which utilizes GaAs Heterojunction Bipolar Transistor (HBT) technology, and is targeted to high volume applications where frequency doubling of a lower frequency is more economical than directly generating a higher frequency. All bond pads and the die backside are Ti/Au metallized and the HBT devices are fully passivated for reliable operation. The HMC-XDB112 Passive Doubler MMIC is compatible with conventional die attach methods, as well as thermocompression and thermosonic wire bonding, making it ideal for MCM and hybrid microcircuit applications. All data shown herein is measured with the chip in a 50 Ohm environment and contacted with RF probes.

### Electrical Specifications\*, $T_A = 25\text{ }^\circ\text{C}$ , $P_{in} = +13\text{ dBm}$

Parameter	Min.	Typ.	Max.	Units
Frequency Range Input	10 - 15			GHz
Frequency Range Output	20 - 30			GHz
Conversion Loss		13		dB
Fo Isolation with respect to output		30		dB

\*Unless otherwise indicated, all measurements are from probed die

## GaAs MMIC PASSIVE FREQUENCY DOUBLER, 10 - 15 GHz INPUT

### Conversion Loss

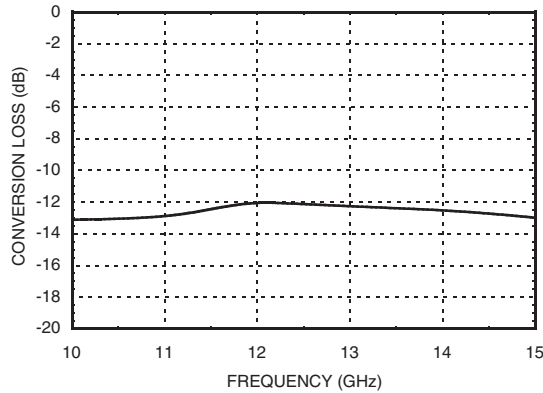

### Output Power

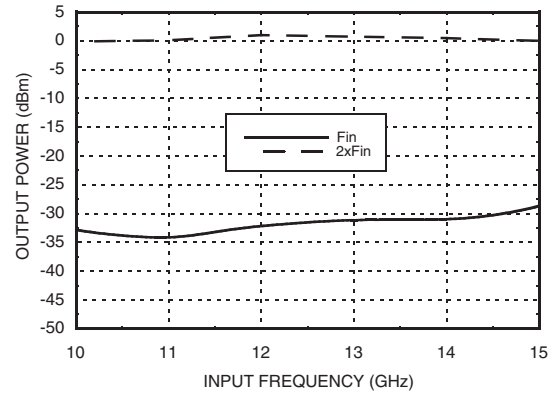

### Outline Drawing



ELECTROSTATIC SENSITIVE DEVICE  
OBSERVE HANDLING PRECAUTIONS

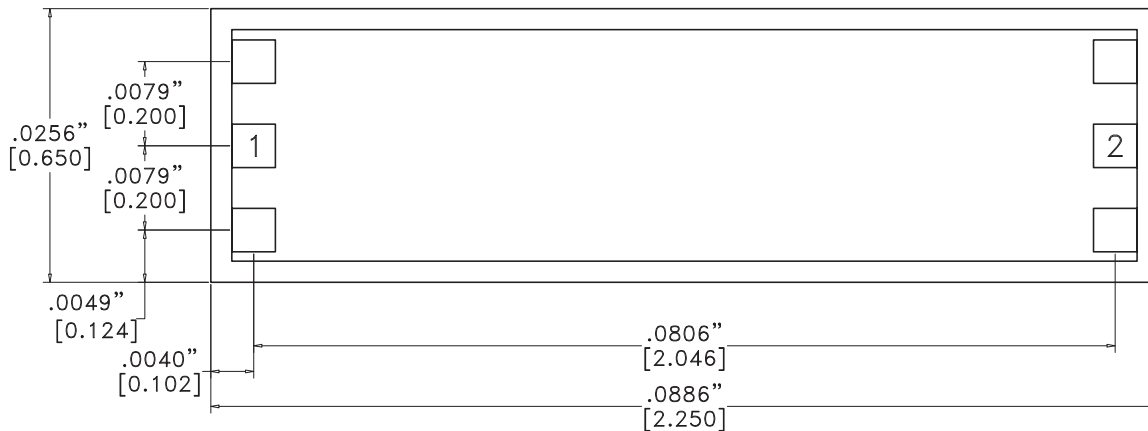

### Die Packaging Information [1]

Standard	Alternate
WP-4 (Waffle Pack)	[2]

[1] Refer to the "Packaging Information" section for die packaging dimensions.

[2] For alternate packaging information contact Hittite Microwave Corporation.

#### NOTES:

1. ALL DIMENSIONS ARE IN INCHES [MM].
2. TYPICAL BOND PAD IS .004" SQUARE.
3. BACKSIDE METALLIZATION: GOLD.
4. BACKSIDE METAL IS GROUND.
5. BOND PAD METALLIZATION: GOLD.
6. CONNECTION NOT REQUIRED FOR UNLABELED BOND PADS.
7. OVERALL DIE SIZE ±.002"

## GaAs MMIC PASSIVE FREQUENCY DOUBLER, 10 - 15 GHz INPUT

### Pad Descriptions

Pad Number	Function	Description	Interface Schematic
1	RFIN	This pad is AC coupled and matched to 50 Ohms.	RFIN ○ —  —
2	RFOUT	This pad is AC coupled and matched to 50 Ohms.	—  — ○ RFOUT
Die Bottom	GND	Die Bottom must be connected to RF/DC ground.	○ GND ⏏

### Assembly Diagram

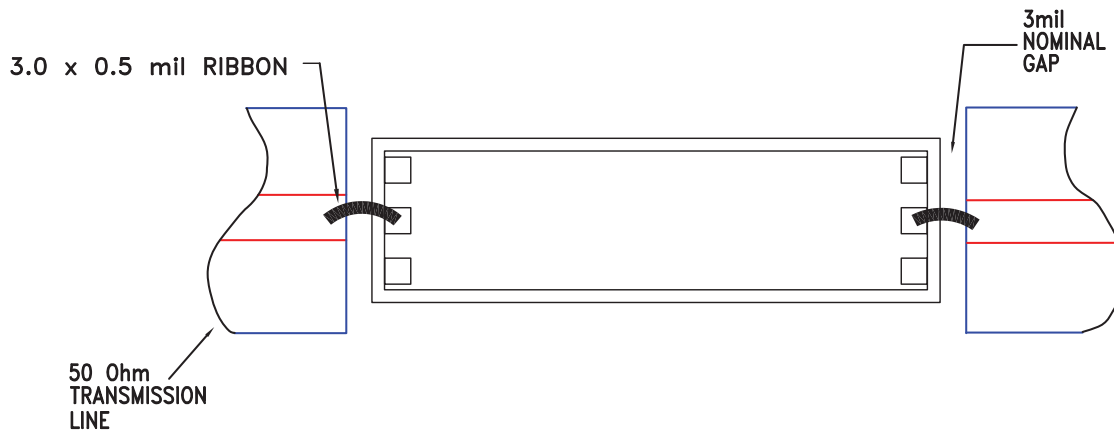

Note 1: Best performance obtained from use of <10 mil (long) by 3 by 0.5 mil ribbons on input and output.

**GaAs MMIC PASSIVE FREQUENCY DOUBLER, 10 - 15 GHz INPUT**

**Mounting & Bonding Techniques for Millimeterwave GaAs MMICs**

The die should be attached directly to the ground plane eutectically or with conductive epoxy (see HMC general Handling, Mounting, Bonding Note).

50 Ohm Microstrip transmission lines on 0.127mm (5 mil) thick alumina thin film substrates are recommended for bringing RF to and from the chip (Figure 1). If 0.254mm (10 mil) thick alumina thin film substrates must be used, the die should be raised 0.150mm (6 mils) so that the surface of the die is coplanar with the surface of the substrate. One way to accomplish this is to attach the 0.102mm (4 mil) thick die to a 0.150mm (6 mil) thick molybdenum heat spreader (moly-tab) which is then attached to the ground plane (Figure 2).

Microstrip substrates should be placed as close to the die as possible in order to minimize bond wire length. Typical die-to-substrate spacing is 0.076mm to 0.152 mm (3 to 6 mils).

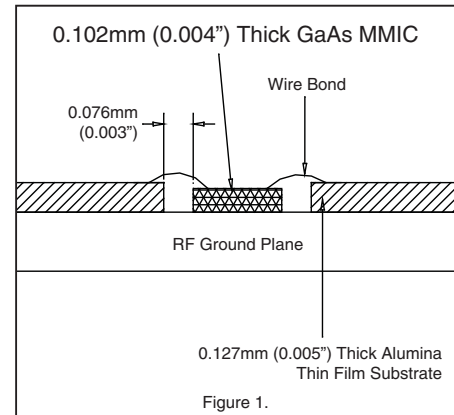

**Handling Precautions**

Follow these precautions to avoid permanent damage.

**Storage:** All bare die are placed in either Waffle or Gel based ESD protective containers, and then sealed in an ESD protective bag for shipment. Once the sealed ESD protective bag has been opened, all die should be stored in a dry nitrogen environment.

**Cleanliness:** Handle the chips in a clean environment. DO NOT attempt to clean the chip using liquid cleaning systems.

**Static Sensitivity:** Follow ESD precautions to protect against ESD strikes.

**Transients:** Suppress instrument and bias supply transients while bias is applied. Use shielded signal and bias cables to minimize inductive pick-up.

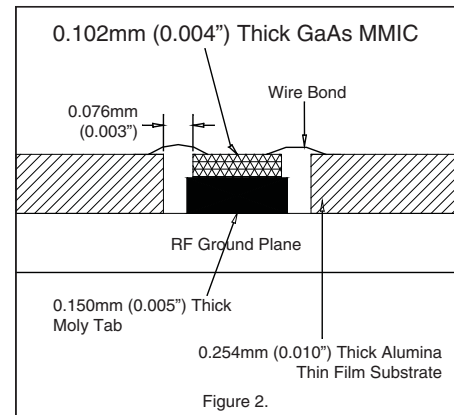

**General Handling:** Handle the chip along the edges with a vacuum collet or with a sharp pair of bent tweezers. The surface of the chip may have fragile air bridges and should not be touched with vacuum collet, tweezers, or fingers.

**Mounting**

The chip is back-metallized and can be die mounted with AuSn eutectic preforms or with electrically conductive epoxy. The mounting surface should be clean and flat.

**Eutectic Die Attach:** A 80/20 gold tin preform is recommended with a work surface temperature of 255 °C and a tool temperature of 265 °C. When hot 90/10 nitrogen/hydrogen gas is applied, tool tip temperature should be 290 °C. DO NOT expose the chip to a temperature greater than 320 °C for more than 20 seconds. No more than 3 seconds of scrubbing should be required for attachment.

**Epoxy Die Attach:** Apply a minimum amount of epoxy to the mounting surface so that a thin epoxy fillet is observed around the perimeter of the chip once it is placed into position. Cure epoxy per the manufacturer's schedule.

**Wire Bonding**

RF bonds made with 0.003" x 0.0005" ribbon are recommended. These bonds should be thermosonically bonded with a force of 40-60 grams. DC bonds of 0.001" (0.025 mm) diameter, thermosonically bonded, are recommended. Ball bonds should be made with a force of 40-50 grams and wedge bonds at 18-22 grams. All bonds should be made with a nominal stage temperature of 150 °C. A minimum amount of ultrasonic energy should be applied to achieve reliable bonds. All bonds should be as short as possible, less than 12 mils (0.31 mm).