



45 Gbps, 4:1 MUX WITH DUTY CYCLE CONTROL & PROGRAMMABLE OUTPUT VOLTAGE

Typical Applications

The HMC847LC5 is ideal for:

- SONET OC-768
- RF ATE Applications
- Broadband Test & Measurements
- Serial Data Transmission up to 45 Gbps
- High Speed DAC Interfacing

Features

- Supports Data Rates up to 45 Gbps
- Half Rate Clock Input
- Quarter Rate Reference Clock Output
- Fast Rise and Fall Times: 11 / 12 ps
- Programmable Differential Output
Voltage Swing: 250 - 900 mVp-p
- Single Supply: +3.3V
- 32 Lead Ceramic 5x5 mm SMT Package: 25 mm²

Functional Diagram

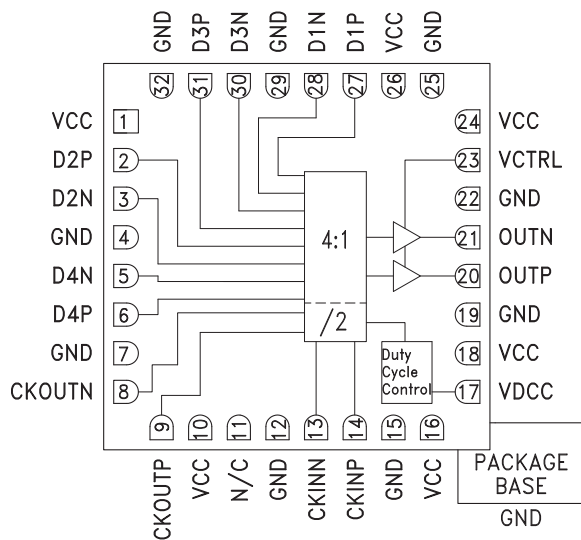

General Description

The HMC847LC5 is a 4:1 multiplexer designed for 45Gbps data serialization. The mux latches the four differential inputs on the transition points of the input clock. The device uses both rising and falling edges of the half-rate clock to serialize the data. A quarter-rate clock output, which is synchronous to the data output of HMC847LC5, is generated on chip.

All clock and data inputs / outputs of the HMC847LC5 are CML and terminated on-chip with 50 Ohms to the, VCC, and may be DC or AC coupled. The inputs and outputs of the HMC847LC5 may be operated either differentially or single-ended. The HMC847LC5 also features an output level control pin, VCTRL, which allows for loss compensation or signal level optimization. The VDCC pin controls the data output cross-point & duty cycle. The HMC847LC5 operates from a single +3.3V supply and is available in ROHS compliant 5x5 mm SMT package.

Electrical Specifications, $T_A = +25^\circ\text{C}$, $V_{cc} = +3.3\text{V}$

Parameter	Conditions	Min.	Typ.	Max	Units
Power Supply Voltage	$\pm 5\%$ Tolerance	3.13	3.3	3.47	V
Power Supply Current	Vctrl = 2.5V	480	540	600	mA
Output Amplitude Control Voltage Range (Vctrl)		1.7	2.5	3	V
Data Output Voltage Swing Range	Differential, peak-to-peak @ 40 Gbps	250		900	mVp-p
Duty Cycle Control Voltage Range (Vdccc)	Vdccc = 1.5V for 50% duty cycle	1	1.5	2	V
Duty Cycle Control Range	@ 40 Gbps	35	50	65	%
Clock Output Voltage Swing	Differential, peak-to-peak @ 10 GHz	480	580	680	mVp-p
Maximum Data Rate		45			Gbps
Maximum Clock Rate	Half Rate Clock	22.5			GHz



45 Gbps, 4:1 MUX WITH DUTY CYCLE CONTROL & PROGRAMMABLE OUTPUT VOLTAGE

Electrical Specifications, (continued)

Parameter	Conditions	Min.	Typ.	Max	Units
Input Amplitude (Data)	Single-Ended, peak-to-peak ^[1]	150		800	mVp-p
	Differential, peak-to-peak	150		1000	mVp-p
Input Amplitude (Clock)	Single-Ended, peak-to-peak ^[1]	100		700	mVp-p
	Differential, peak-to-peak	100		1000	mVp-p
Input High Voltage (Data & Clock)	Vctrl = 2.5V	2.8		3.8	V
Input Low Voltage (Data & Clock)	Vctrl = 2.5V	2.3		3.3	V
Output High Voltage	Vctrl = 2.5V		2.94		V
Output Low Voltage	Vctrl = 2.5V		2.62		V
Input Return Loss	Data input up to 11.25 GHz		10		dB
	Clock input up to 22.5 GHz		12		dB
Output Return Loss	Data output up to 22.5 GHz		10		dB
	Clock output up to 11.25 GHz		10		dB
Deterministic Jitter, Jd ^[2]			3		ps p-p
Additive Random Jitter, Jr ^[3]			0.27		ps rms
Rise Time, tr ^[2]	20% - 80%		11		ps
Fall Time, tf ^[2]	20% - 80%		12		ps
Propagation Delay Clock to Data, Tdpd	Input clock to output data		400		ps
Propagation Delay Clock to Output Clock, Tcpd	Input clock to output clock		85		ps
Set Up Time, ts	Both at rising and falling edges		5		ps
Hold Time, th	Both at rising and falling edges		4		ps

[1]The un-used port is biased @ 3.3V

[2] CKINP: 20 GHz clock signal, 300 mVp-p single-ended, D1P-D4P: 10 Gbps PRBS 2²³-1 pattern, 300 mVp-p single-ended

[3] Random jitter is measured with 40 Gbps 10101... pattern

DC Current vs. Supply Voltage ^{[1] [2]}

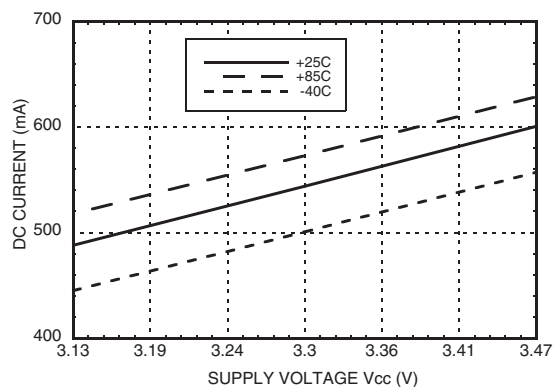

Differential Output Swing vs. Supply Voltage ^{[1] [2]}

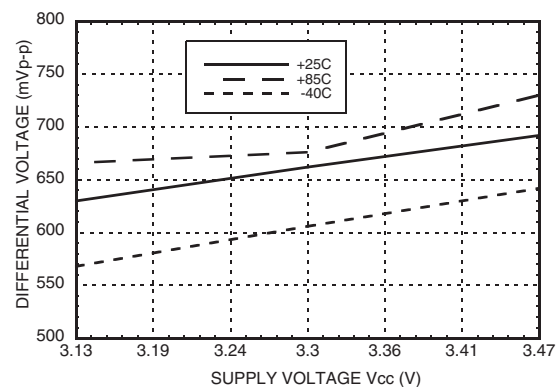

[1] Vctrl = 2.5V

[2] Data Rate = 40 Gbps



45 Gbps, 4:1 MUX WITH DUTY CYCLE CONTROL & PROGRAMMABLE OUTPUT VOLTAGE

3

MUX & DEMUX - SMT

DC Current vs. Vctrl [1]

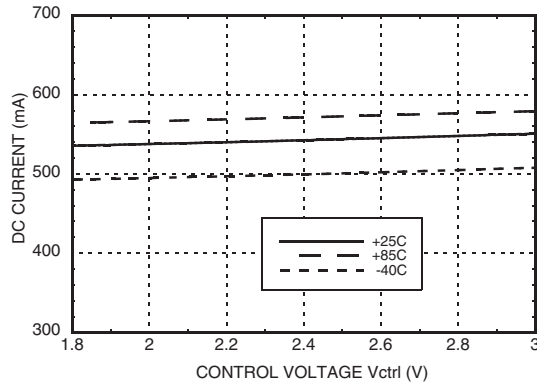

Differential Output Swing vs. Vctrl [1]

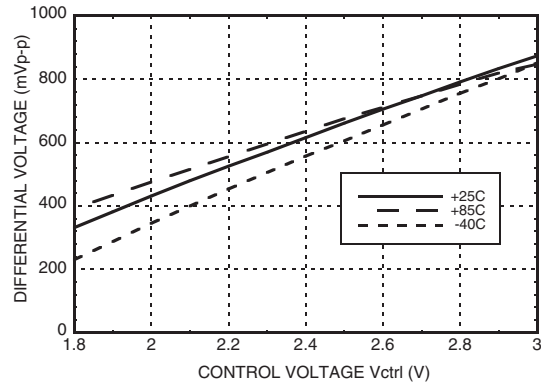

Rise Time vs. Supply Voltage [1][2][3][4]

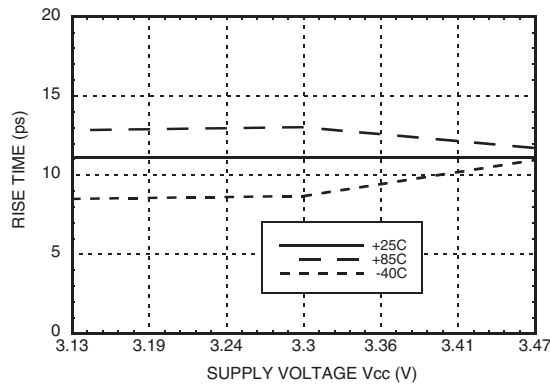

Fall Time vs. Supply Voltage [1][2][3][4]

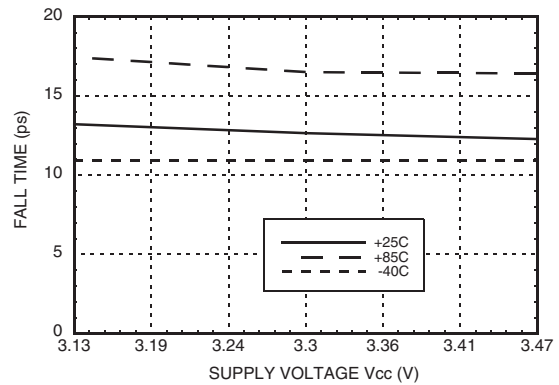

Rise Time vs. Vctrl [1][3][4]

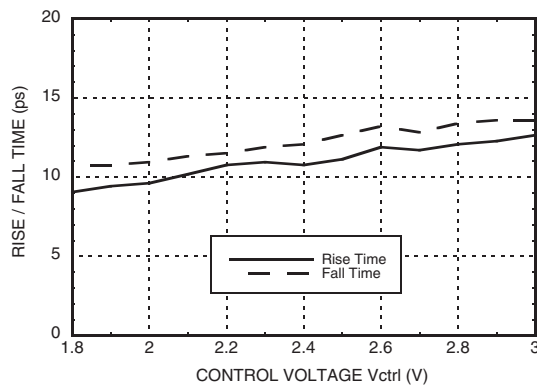

Peak-to-Peak Jitter vs. Supply Voltage [1][2][3][5]

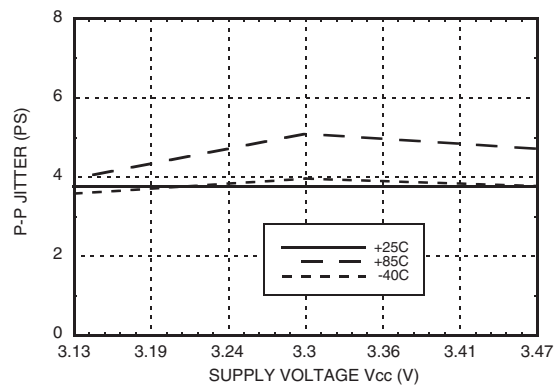

[1] Data Rate = 40 Gbps [2] Vctrl = 2.5V [3] Data was taken at single-ended output [4] 20% - 80%
 [5] Source jitter was not deembedded



45 Gbps, 4:1 MUX WITH DUTY CYCLE CONTROL & PROGRAMMABLE OUTPUT VOLTAGE

Data Input Return Loss vs. Frequency [1][2]

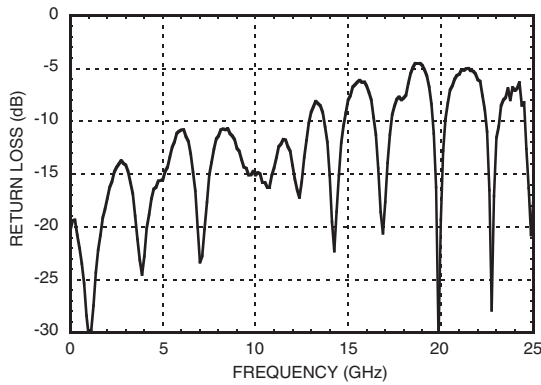

Data Output Return Loss vs. Frequency [1][2]

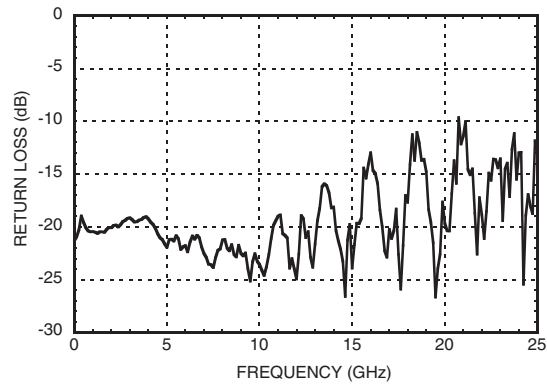

Clock Input Return Loss vs. Frequency [1][2]

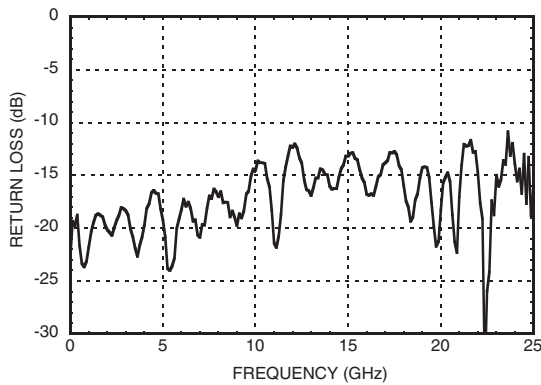

Clock Output Return Loss vs. Frequency [1][2]

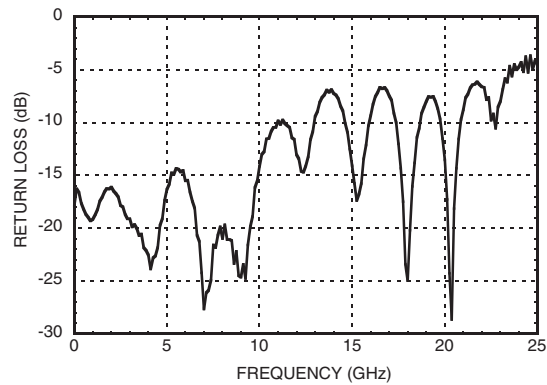

40 Gbps Single-Ended Output Eye Diagram

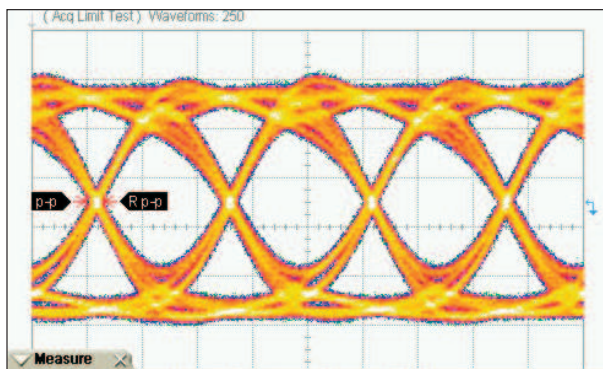

Measurements				
	Current	Minimum	Maximum	Total Meas.
Eye Amp	321 mV	321 mV	321 mV	78
Rise Time	13.33 ps	11.33 ps	13.78 ps	78
Fall Time	13.78 ps	13.56 ps	14.22 ps	78
p-p jitter	3.333 ps	2.444ps	3.333 ps	78

Time Scale: 10 ps/div
Amplitude Scale: 85.4 mV/div

Test Conditions:

VCC = +3.3V, VCTRL = 2.5V

D1P-D4P: 10 Gbps NRZ PRBS 2²³-1 pattern, 300 mVp-p single-ended

CKINP: 20 GHz Clock Signal, 300 mVp-p single-ended

[1] Vctrl = 2.5V

[2] Device measured on evaluation board with single ended time domain gating



45 Gbps, 4:1 MUX WITH DUTY CYCLE CONTROL & PROGRAMMABLE OUTPUT VOLTAGE

20 Gbps Single-Ended Output Eye Diagram

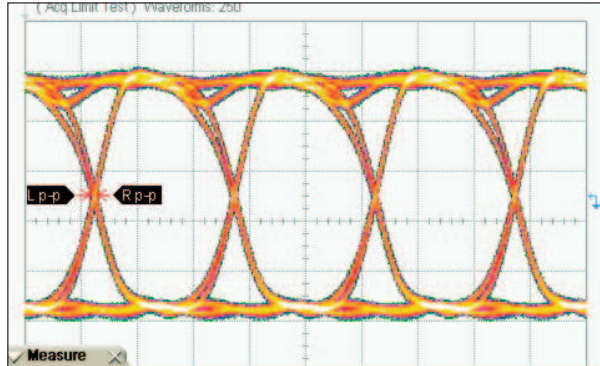

Measurements				
	Current	Minimum	Maximum	Total Meas.
Eye Amp	361 mV	361 mV	361 mV	83
Rise Time	12.00 ps	11.56 ps	12.00 ps	83
Fall Time	14.67 ps	14.22 ps	15.11 ps	83
p-p jitter	2.667 ps	1.778ps	2.667 ps	83

Time Scale: 20 ps/div
Amplitude Scale: 80 mV/div

Test Conditions:
VCC = +3.3V, VCTRL = 2.5V
D1P-D4P: 5 Gbps NRZ PRBS 2²³-1 pattern, 300 mVp-p single-ended
CKINP: 20 GHz Clock Signal, 300 mVp-p single-ended

Timing Diagram

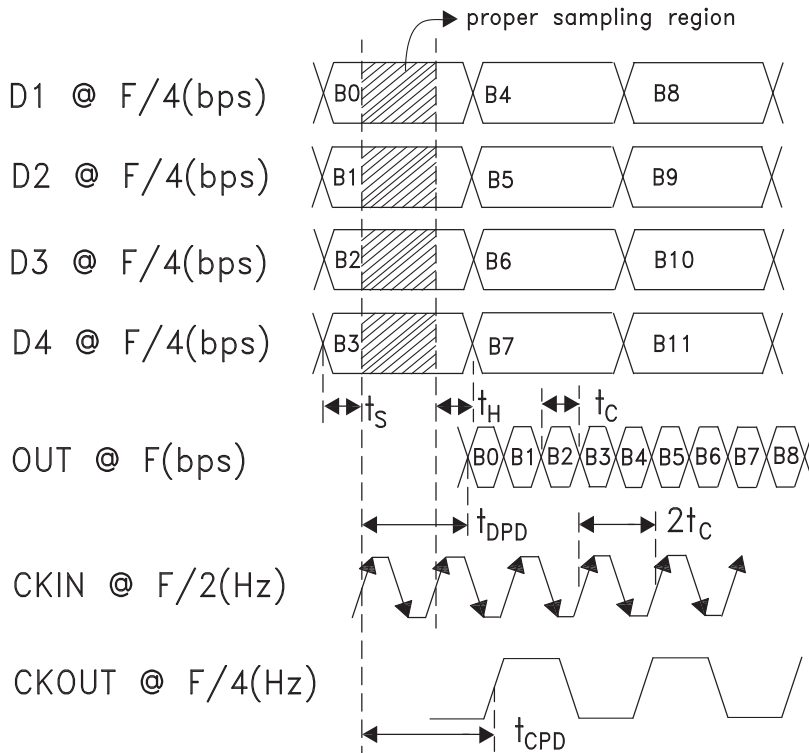



45 Gbps, 4:1 MUX WITH DUTY CYCLE CONTROL & PROGRAMMABLE OUTPUT VOLTAGE

Absolute Maximum Ratings

Power Supply Voltage (Vcc)	3.7V to +0.5V
Input Voltages	Vcc -2V to Vcc +0.5V
DC Control Pins (Vctrl, Vdcc)	Vcc +0.2V to Vcc -2.5V
Channel Temperature	125 °C
Continuous P _{diss} (T = 85 °C) (derate 50.91 mW/°C above 85 °C)	2.04 W
Thermal Resistance (Channel to die bottom)	19.64 °C/W
Storage Temperature	-65°C to +150°C
Operating Temperature	-40°C to +85°C



ELECTROSTATIC SENSITIVE DEVICE
OBSERVE HANDLING PRECAUTIONS

3

Outline Drawing

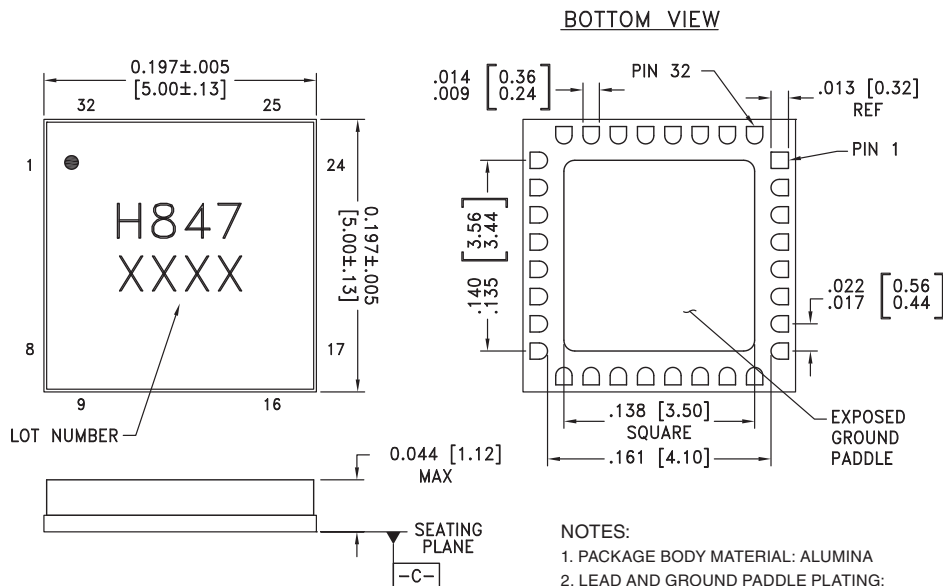

NOTES:

1. PACKAGE BODY MATERIAL: ALUMINA
2. LEAD AND GROUND PADDLE PLATING:
30-80 MICROINCHES GOLD OVER 50 MICROINCHES MINIMUM NICKEL.
3. DIMENSIONS ARE IN INCHES [MILLIMETERS].
4. LEAD SPACING TOLERANCE IS NON-CUMULATIVE.
5. PACKAGE WARP SHALL NOT EXCEED 0.05mm DATUM -C-
6. ALL GROUND LEADS MUST BE SOLDERED TO PCB RF GROUND.
7. PADDLE MUST BE SOLDERED TO V_{ee}.

Pin Descriptions

Pin Number	Function	Description	Interface Schematic
1, 10, 16, 18, 24, 26	VCC	Power Supply (3.3V)	
2, 3, 5, 6, 27, 28, 30, 31	D2P, D2N, D4N, D4P, D1P, D1N, D3N, D3P	Differential 4 Channel Serial Data Inputs.	



45 Gbps, 4:1 MUX WITH DUTY CYCLE CONTROL & PROGRAMMABLE OUTPUT VOLTAGE

Pin Descriptions (Continued)

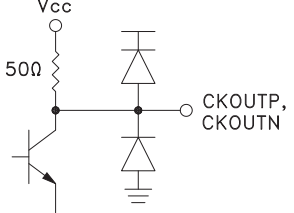
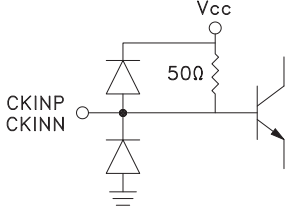
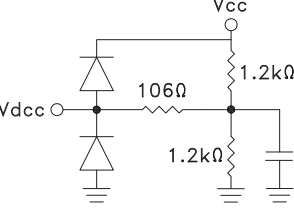
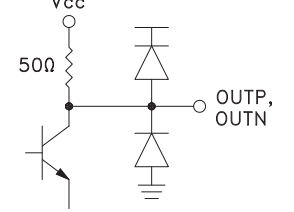
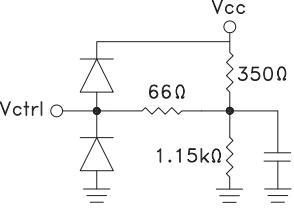
Pin Number	Function	Description	Interface Schematic
4, 7, 12, 15, 19, 22, 25, 29, 32	GND	Signal and supply ground	
8, 9	CKOUTN, CKOUTP	Differential Quarter Rate System Clock Outputs.	
11	N/C	Not connected.	
13, 14	CKINN, CKINP	Differential Half Rate Clock Inputs.	
17	Vdcc	Output Duty Cycle Correction Control	
20, 21	OUTP, OUTN	Differential High Speed Serial Data Outputs	
23	Vctrl	Output Amplitude Control	

45 Gbps, 4:1 MUX WITH DUTY CYCLE CONTROL & PROGRAMMABLE OUTPUT VOLTAGE

Evaluation PCB

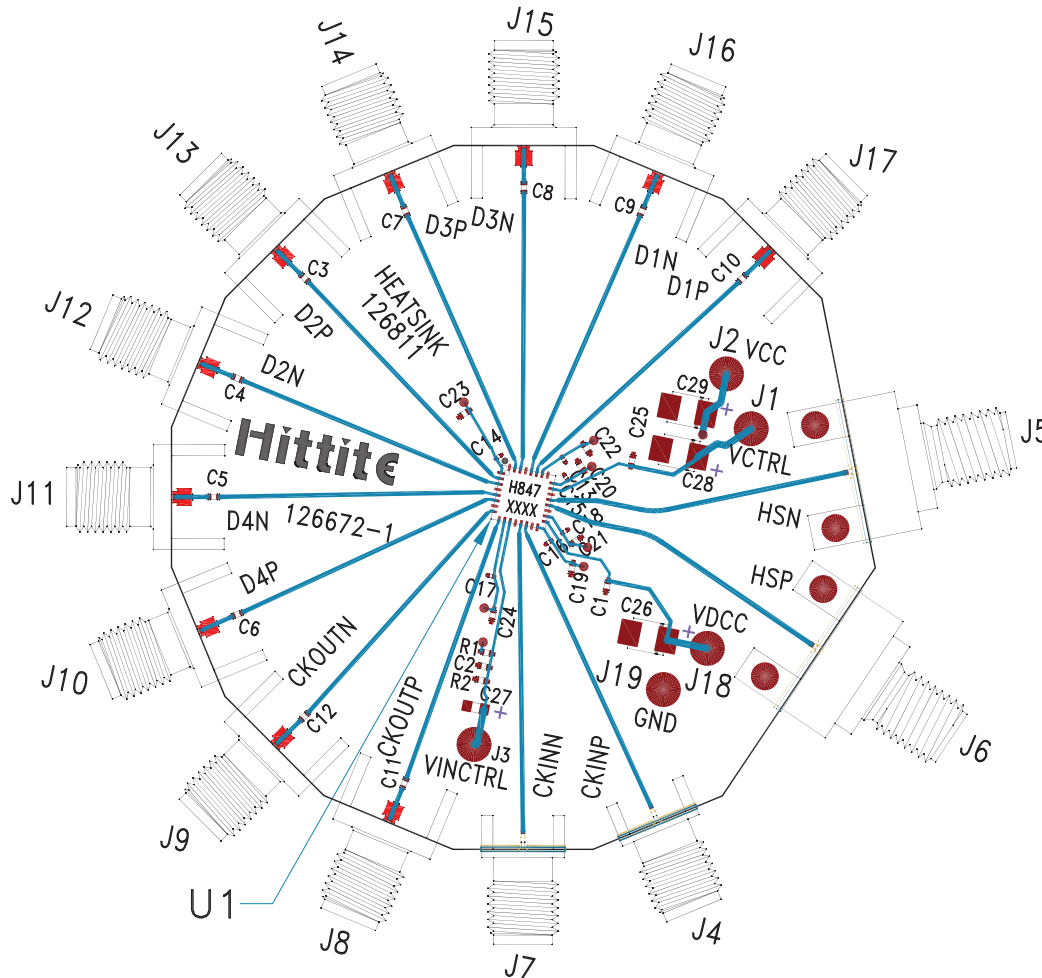

List of Materials for Evaluation PCB 126674 [1]

Item	Description
J1, J2, J18, J19	DC Connector
J4, J7	K Connector
J5, J6	2.4mm Connector
J8 - J17	SMA Connector
C1, C19 - C25	100 nF Capacitor, 0402 Pkg.
C3 - C12	10 nF Capacitor, 0402 Pkg.
C13 - C18	1 nF Capacitor, 0201 Pkg.
C26, C28, C29	4.7 μF Capacitor, Tantalum
U1	HMC847LC5 45 Gbps 4:1 Mux
PCB [2]	126672 Evaluation Board

[1] Reference this number when ordering complete evaluation PCB

[2] Circuit Board Material: Arlon 25FR or Rogers 4350

The circuit board used in the application should use RF circuit design techniques. Signal lines should have 50 Ohm impedance while the package ground leads should be connected directly to the ground plane similar to that shown. The exposed metal package base must be connected to GND. A sufficient number of via holes should be used to connect the top and bottom ground planes. The evaluation circuit board shown is available from Hittite upon request.



45 Gbps, 4:1 MUX WITH DUTY CYCLE CONTROL & PROGRAMMABLE OUTPUT VOLTAGE

Application Circuit

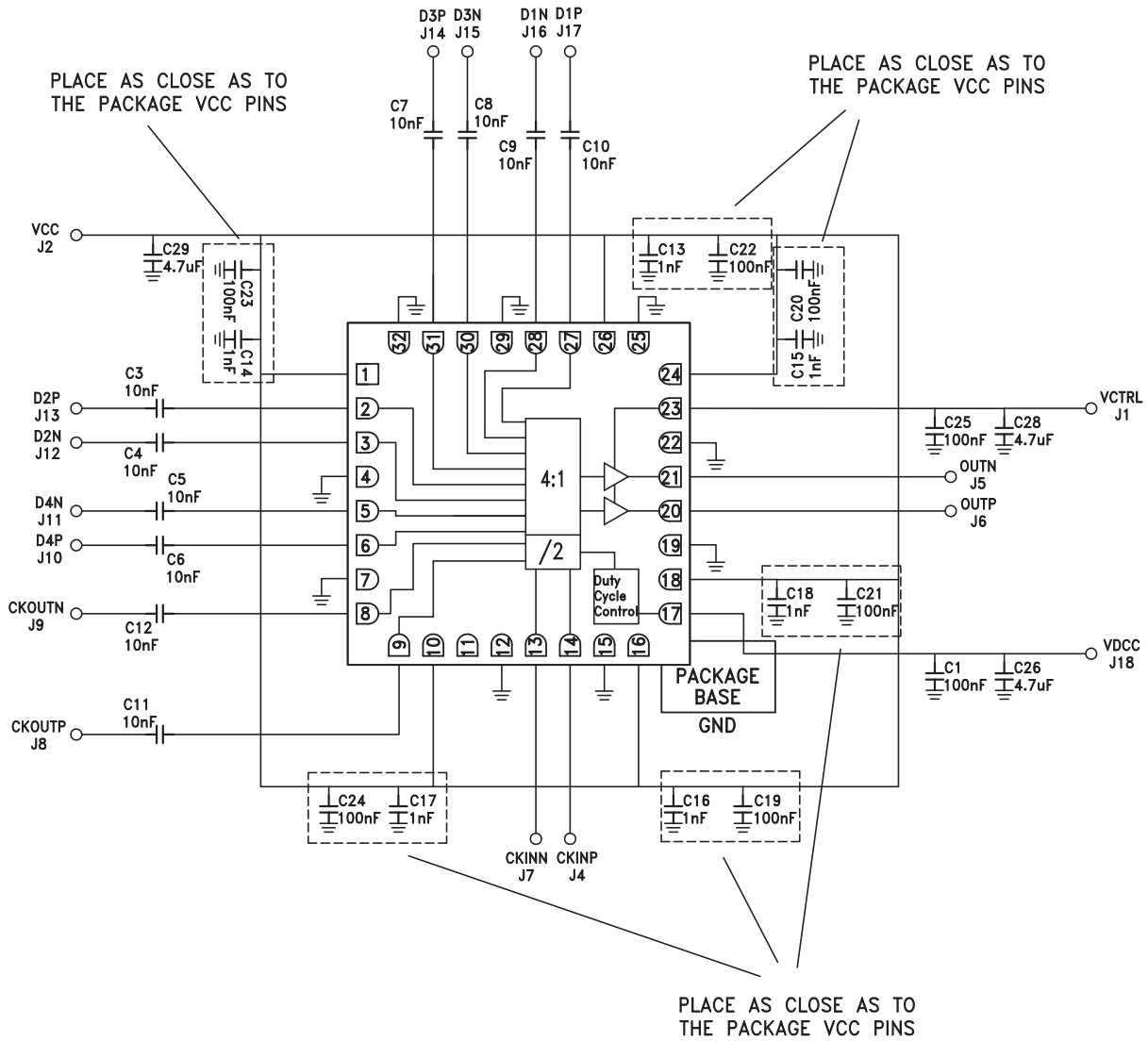



**45 Gbps, 4:1 MUX WITH DUTY CYCLE CONTROL
& PROGRAMMABLE OUTPUT VOLTAGE**

Notes: