

Typical Applications

The HMC704LP4E is ideal for:

- Microwave Point-to-Point Radios
- Base Stations for Mobile Radio (GSM, PCS, DCS, CDMA, WCDMA)
- Wireless LANs, WiMAX
- Communications Test Equipment
- CATV Equipment
- Automotive

Features

Wide band: DC - 8 GHz RF Input,
4 GHz 19-bit Prescaler

Industry Leading Phase Noise & Spurious:
-112 dBc/Hz @ 8 GHz Fractional, 50 kHz Offset

Figure of Merit

-230 dBc/Hz Fractional Mode

-233 dBc/Hz Integer Mode 100 MHz PFD

High PFD rate: 100 MHz

24 Lead 4x4 mm SMT Package: 16 mm²

Functional Diagram

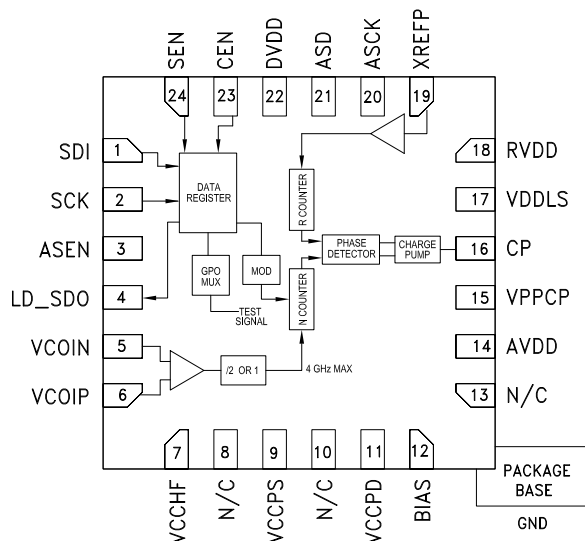

General Description

The HMC704LP4E has been designed for the best phase noise and lowest spurious content possible in an integrated PLL.

Fabricated in a SiGe BiCMOS process, this Fractional-N PLL consists of a very low noise digital phase detector, VCO divider, reference divider and a precision controlled charge pump.

Ultra low in-close phase noise and low spurious allows wide loop bandwidths for faster frequency hopping and low micro-phonics.

Exact frequency mode with 24-bit fractional modulator provides the ability to generate fractional frequencies with zero frequency error, an important feature for Digital Pre-Distortion systems.

The serial interface offers read back capability and is compatible with a wide variety of protocols.

Table 1. Electrical Specifications

VDDCP, VPPCP = 5V+/-4%; RVDD, AVDD, DVDD, VDDPD, VCCPS = 3.3V +/-10%; AGND = DGND = 0V

Parameter	Conditions	Min.	Typ.	Max.	Units
RF INPUT CHARACTERISTICS					
RF Input Frequency Range	[1]	DC		8000	MHz
Prescaler Input Freq Range	[1]	DC		4000	MHz
Power Range	[13]	-15	-7	-3	dBm
Impedance	100 Ohms each leg 3pF		100 3		Ohms pF
REF INPUT CHARACTERISTICS					
Frequency Range (3.3V)	[1][8]	DC	50	350	MHz
Power from 50Ohm Source	[12]		6		dBm
Impedance			100 3		Ohms pF
Ref Divider Range (14 bit)		1		16,383	
PHASE DETECTOR RATE					
Integer Mode		DC	50	115	MHz
Fractional Mode A		DC	50	80	MHz
Fractional Mode B		DC	50	100	MHz
CHARGE PUMP					
Output Current	20uA Steps	0.02		2.5	mA
POWER SUPPLIES					
RVDD, AVDD, VCCPS, VCCHF, VCCPD - Analog supply	All should be equal	3.0	3.3	3.5	V
DVDD - Digital supply		3.0	3.3	3.5	V
VDDLs, VPPCP Charge Pump	VDDLs, VPPCP must be equal	4.7	5.0	5.2	V
3.3V - Current consumption	[9]	38	52	58	mA
5V - Current consumption	All Modes	2	6	7	mA
Power Down Current	[10]			100	uA
BIAS Reference Voltage	Pin 12. Measured with 10GOhm Meter	1.880	1.920	1.960	V
PHASE NOISE					
Flicker Figure of Merit (FOM)[2]			-266		dBc/Hz
Floor Figure of Merit [11]	Integer HiK Mode Integer Normal Mode Fractional HiK Mode [3] Fractional Normal Mode [3]	-236 -232 -232 -228	-233 -230 -230 -227	-231 -228 -227 -225	dBc/Hz dBc/Hz dBc/Hz dBc/Hz
Flicker Noise at f_{offset}	$PN_{flick} = \text{Flicker FOM} + 20\log(f_{vco}) - 10\log(f_{offset})$				dBc/Hz
Phase Noise Floor at f_{vco} with f_{pd}	$PN_{floor} = \text{Floor FOM} + 10\log(f_{pd}) + 20\log(f_{vco}/f_{pd})$				dBc/Hz
Total Phase Noise vs f_{offset} , f_{vco} , f_{pd}	$PN = 10\log(10(PN_{flick}/10) + 10(PN_{floor}/10))$				dBc/Hz
Jitter	SSB 100Hz to 50kHz		50		fs
SPURIOUS					
Integer Boundary Spurs @~8GHz	offsets less than loop bandwidth, $f_{pd} = 50\text{MHz}$		-60	-52	dBc
LOGIC INPUTS					

Table 1. Electrical Specifications (Continued)

Parameter	Conditions	Min.	Typ.	Max.	Units
VIH Input High Voltage				VDD-0.4	V
VIL Input Low Voltage		0.4			V
LOGIC OUTPUTS					
VOH Output High Voltage				VDD-0.4	V
VOL Output Low Voltage		0.4			V
Digital Output Driver Delay SCK to Digital Output Delay	1.7nsec with a 3pF load		0.5ns+0.2ns/pF 8.2ns+0.2ns/pF		ns ns
RF divider 8GHz Integer Mode	19 bit , Even values Only	32		1,048,574	
RF divider 4GHz Integer Mode	19 bit , All values	16		524,287	
RF divider 8GHz Fractional Mode	19 bit , Even values Only	40		1,048,566	
RF divider 4GHz Fractional Mode	19 bit , All values	20		524,283	

[1] Frequency is guaranteed across process, voltage and temperature from -40°C to 85°C.

[2] With high charge-pump current, +12dBm 100MHz sine reference

[3] Fractional FOM degrades about 3dB/octave for prescaler input frequencies below 2GHz

[4] Using 50MHz reference with VCO tuned to within one loop bandwidth of an integer multiple of the PD frequency. Larger offsets produce better results. See the “Spurious Performance” section for more information.

[5] Measured with the HMC704LP4E evaluation board. Board design and isolation will affect performance.

[6] Internal divide-by-2 must be enabled for frequencies >4GHz

[7] At low RF Frequency, Rise and fall times should be less than 1ns to maintain performance

[8] Slew rate of greater or equal to 0.5ns/V

[9] Current consumption depends upon operating mode and frequency of the VCO

[10] Reference input disconnected

[11] Min/Max versus temperature and supply, under typical reference & frequencies & RF power levels

[12] Slew > 0.5V/ns is recommended , see [Table 6](#) for more information

[13] Operable with reduced spectral performance up to +7 dBm



TYPICAL PERFORMANCE CHARACTERISTICS

Unless otherwise specified, plots are measured with a 50 MHz PD rate, VCO near 8 GHz. The operating modes in the following plots refer to Integer (int), Fractional Modes A and B, HiKcp (HiK) or Active (act) configurations.

Figure 1. Floor FOM vs. Mode and Temp

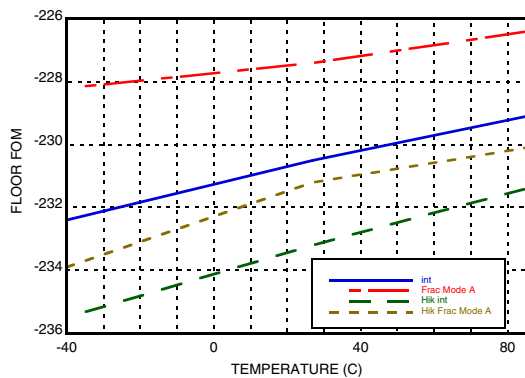

Figure 2. Flicker FOM vs. Mode and Temp

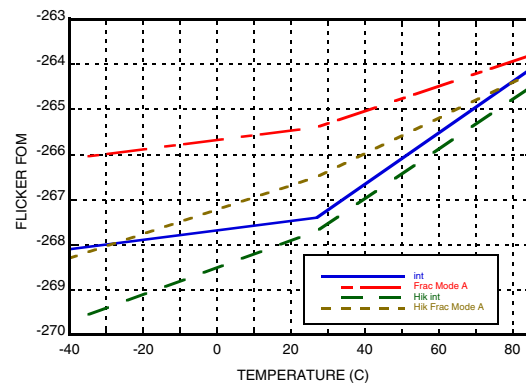

Figure 3. Floor FOM vs. Output Frequency and Mode

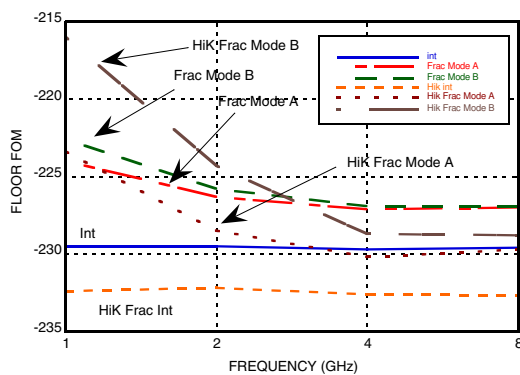

Figure 4. Flicker FOM vs. Output Frequency and Mode

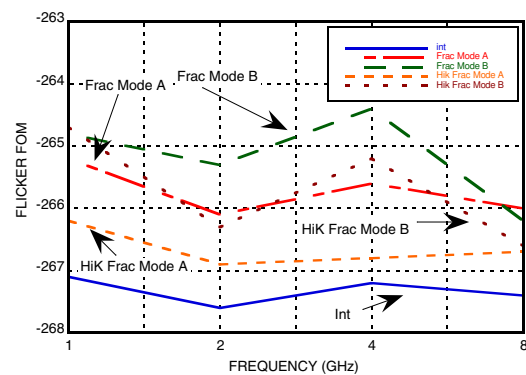



Figure 5. Floor FOM vs. Reference Power and Mode

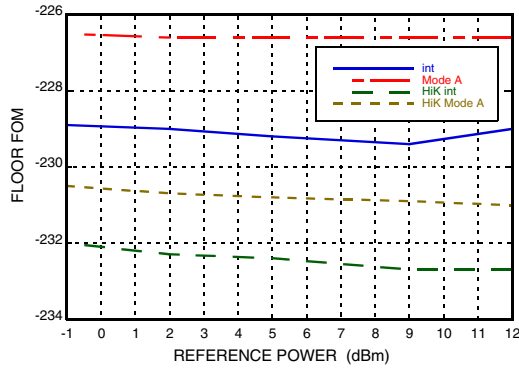

Figure 6. Flicker FOM vs. Reference Power and Mode

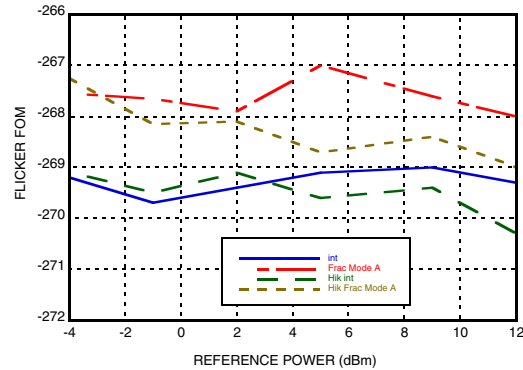

Figure 7. Flicker FOM vs. Charge Pump Current

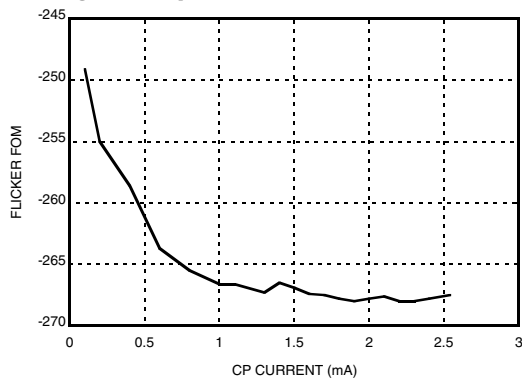

Figure 8. Flicker FOM vs. CP Voltage, CP Current = 2.5mA

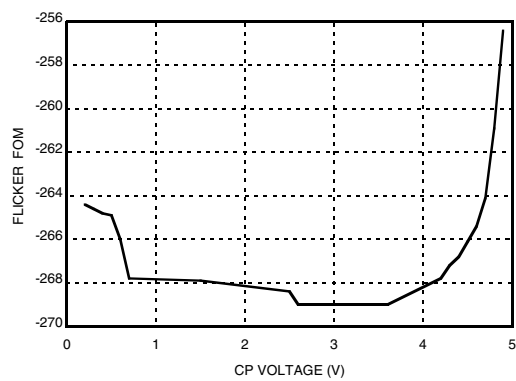

Figure 9. Flicker FOM vs. CP Voltage, Hikcp + CP Current = 6mA

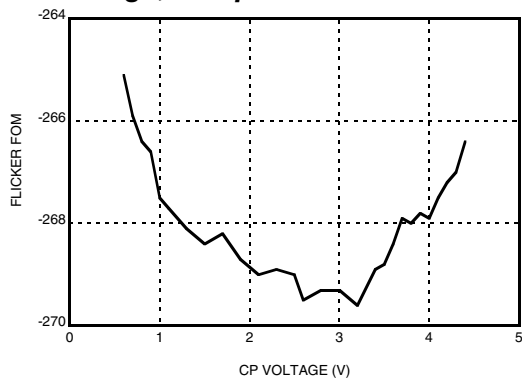

Figure 10. Floor FOM vs. CP Voltage, CP Current = 2.5mA

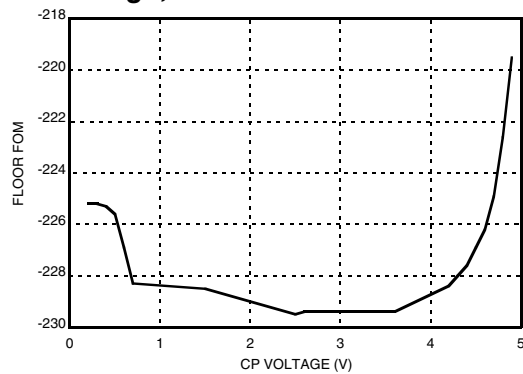



Figure 11. Floor FOM vs. CP Voltage, Hikcp+CP Current = 6mA

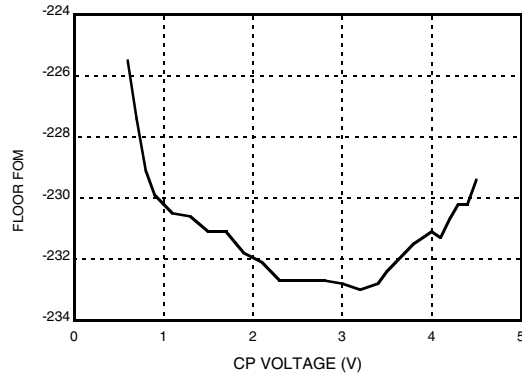

Figure 12. Floor FOM vs. CP Current

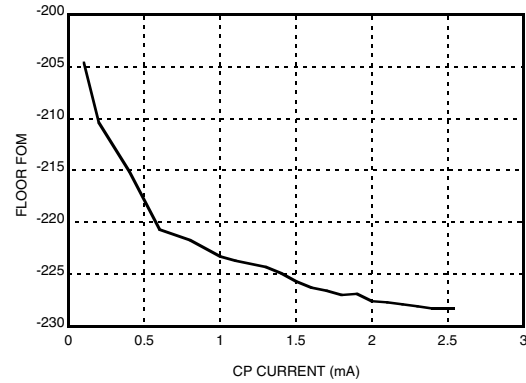

Figure 13. Spur Performance vs. Frequency Offset^[1]

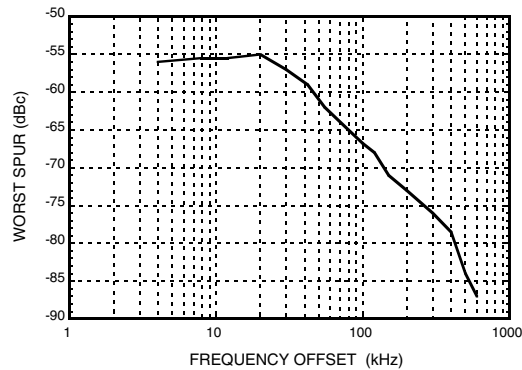

Figure 14. Spur Performance vs. Frequency Offset^[2]

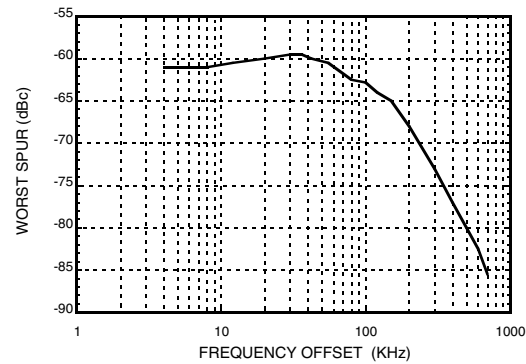

Figure 15. Worst Case Integer Boundary Spur Near 8 GHz

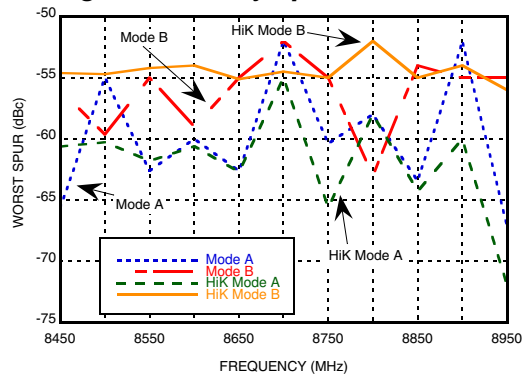
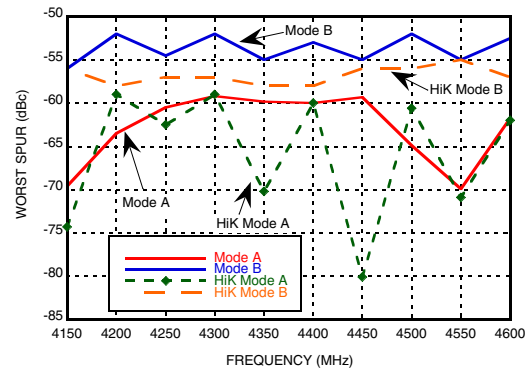

Figure 16. Worst Case Integer Boundary Spur Near 4 GHz



[1] CP Current = 2.5 mA, Loop Filter = 20 kHz, Phase Margin = 78°
[2] Hi K, CP Current = 6 mA, Loop Filter BW = 45 kHz, Phase Margin = 78°



Figure 17. Integer Boundary Spur vs. CP Offset [3]

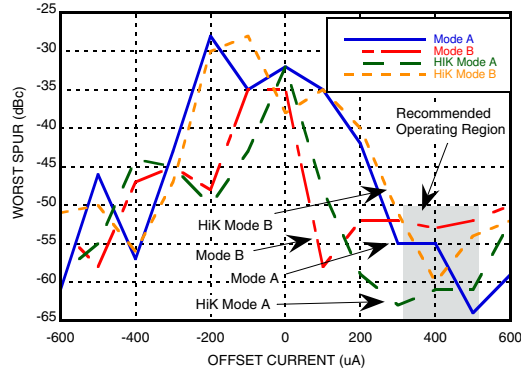

Figure 18. Modelled vs. Measured Phase Noise [4]

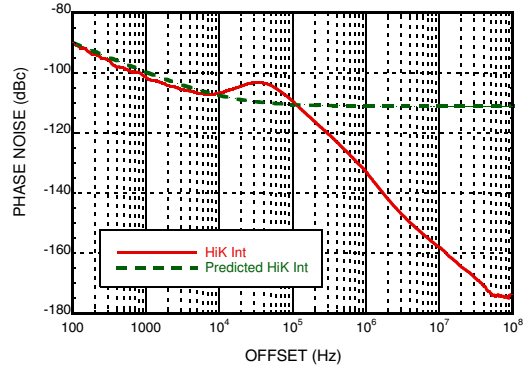

Figure 19. Modelled vs. Measured Phase Noise, Fractional Mode [3]

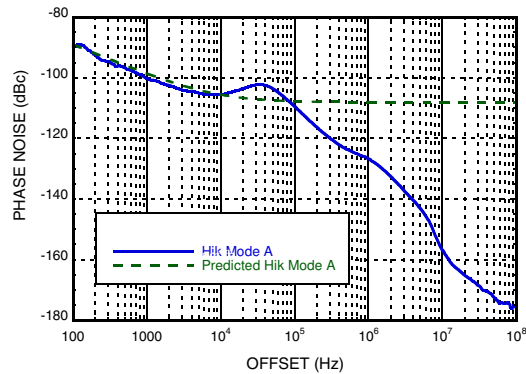

Figure 20. Floor FOM Near 8 GHz vs. RF Power and Mode

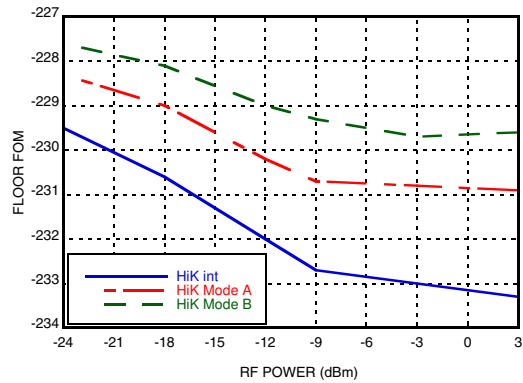

Figure 21. Flicker FOM Near 8 GHz vs. RF Power and Mode

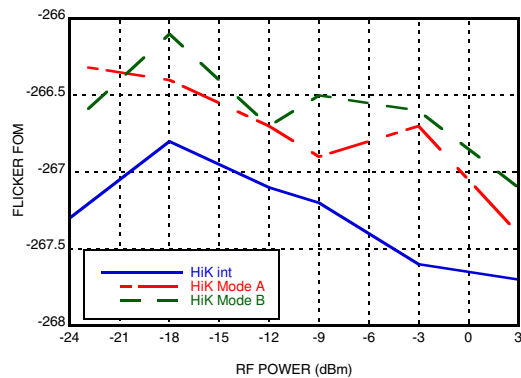
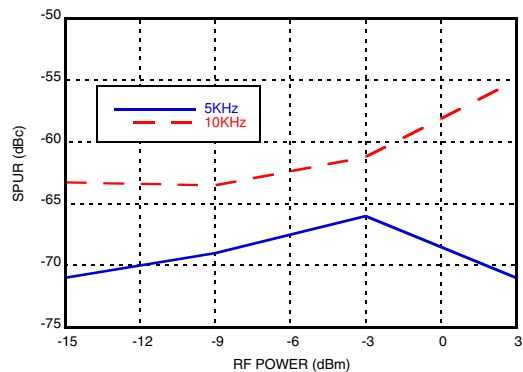

Figure 22. Integer Boundary Spurious at 8 GHz + 10 kHz vs. RF Power [3]



[3] VCO Near 8.6 GHz, Prescaler = VCO/2

[4] Active Fractional A Mode (Prescaler @ 4 GHz + 5 kHz)



Table 2. Pin Descriptions

Pin Number	Function	Description
1	SDI	Main Serial port data input
2	SCK	Main Serial port clock input
3	ASEN	Auxiliary Serial Port Enable Output
4	LD_SDO	Lock Detect Output or Serial Data Output or GPO, Selectable
5	VCOIN	Complementary Input to the RF Prescaler. For Single Ended operation must be decoupled to the ground plane with a ceramic bypass capacitor, typically 100 pF. DC Bias of 2.0V is generated internally
6	VCOIP	Input to the RF Prescaler. Small signal input from external VCO. DC Bias of 2.0V is generated internally. External AC Coupling required
7	VCCHF	Power supply pin for the RF Section. Nominal +3.3 V. A decoupling capacitor to the ground plane should be placed as close as possible to this pin. see eval board layout.
8	N/C	No Connect
9	VCCPS	Power Supply Prescaler, Nominal +3.3V
10	N/C	No Connect
11	VCCPD	Power supply for the phase detector, Nominal +3.3V
12	BIAS	External bypass decoupling for precision bias circuits, 1.920V +/-20mV NOTE: BIAS ref voltage cannot drive an external load. Must be measured with 10GOhm meter such as Agilent 34410A, normal 10Mohm DVM will read erroneously.
13	N/C	No Connect
14	AVDD	Power supply for analog bias generation, Nominal +3.3V
15	VPPCP	Power supply for charge pump, Nominal +5V
16	CP	Charge pump output.
17	VDDL5	Power Supply for charge pump digital section, Nominal +5V
18	RVDD	Ref path supply, Nominal +3.3V
19	XREFP	Reference input
20	ASCK	Auxiliary Serial Port Clock Output
21	ASD	Auxiliary Serial Port Data Output
22	DVDD	Digital supply, Nominal +3.3V
23	CEN	Hardware Chip Enable
24	SEN	Main Serial port latch enable input

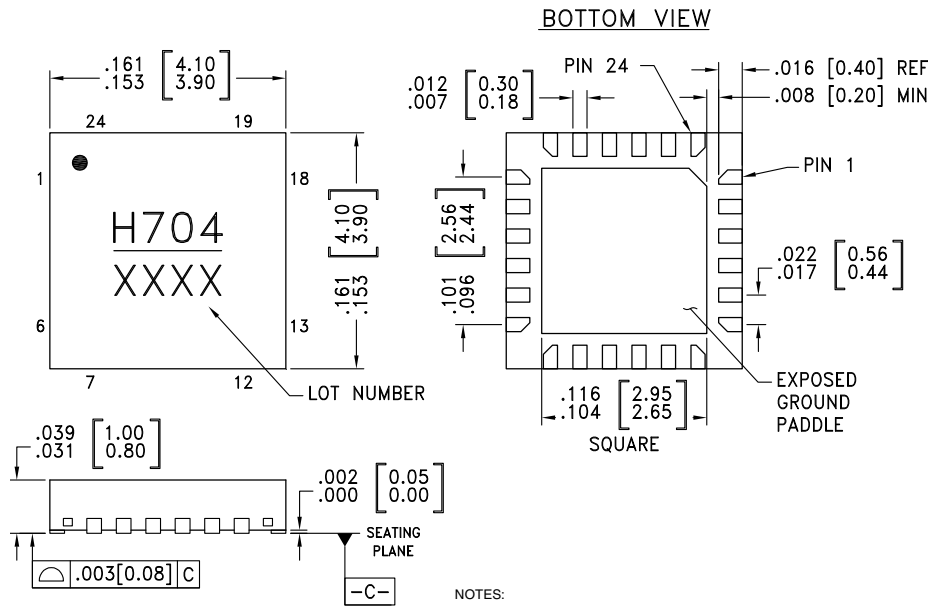

Table 3. Absolute Maximum Ratings

Parameter	Rating
AVDD or DVDD to GND	-0.3V to +3.6V
AVDD to DVDD	-0.5V to +0.5V
VDDLs, VPPCP	-0.3V to +5.2V
VCOIN, VCOIP Single Ended DC	VCCHF-0.2V
VCOIN, VCOIP Differential DC	5.2V
VCOIN, VCOIP Single Ended AC 50Ohm	+7 dBm
VCOIN, VCOIP Differential AC 50Ohm	+13 dBm
Digital Load	1kOhm min
Digital Input 1.4V to 1.7V min rise time	20nsec
Digital Input Voltage Range	-0.25 to DVDD+0,5V
Thermal Resistance (Jxn to Gnd Paddle)	25 °C/W
Operating Temperature Range	-40 °C to +85 °C
Storage Temperature Range	-65 °C to + 125 °C
Maximum Junction Temperature	+125 °C
Reflow Soldering	
Peak Temperature	260 °C
Time at Peak Temperature	40sec
ESD Sensitivity HBM	Class 1B

Stresses above those listed under Absolute Maximum Ratings may cause permanent damage to the device. This is a stress rating only; functional operation of the device at these or any other conditions above those indicated in the operational section of this specification is not implied. Exposure to absolute maximum rating conditions for extended periods may affect device reliability.



Outline Drawing



- NOTES:
- [1] PACKAGE BODY MATERIAL: LOW STRESS INJECTION MOLDED PLASTIC SILICA AND SILICON IMPREGNATED.
 - [2] LEAD AND GROUND PADDLE MATERIAL: COPPER ALLOY.
 - [3] LEAD AND GROUND PADDLE PLATING: 100% MATTE TIN.
 - [4] DIMENSIONS ARE IN INCHES [MILLIMETERS].
 - [5] LEAD SPACING TOLERANCE IS NON-CUMULATIVE.
 - [6] PAD BURR LENGTH SHALL BE 0.15mm MAX. PAD BURR HEIGHT SHALL BE 0.05mm MAX.
 - [7] PACKAGE WARP SHALL NOT EXCEED 0.05MM
 - [8] ALL GROUND LEADS AND GROUND PADDLE MUST BE SOLDERED TO PCB RF GROUND.
 - [9] REFER TO HITTITE APPLICATION NOTE FOR SUGGESTED PCB LAND PATTERN.

Table 4. Package Information

Part Number	Package Body Material	Lead Finish	MSL Rating	Package Marking [1]
HMC704LP4E	RoHS-compliant Low Stress Injection Molded Plastic	100% matte Sn	MSL1[2]	H704 XXXX

[1] 4-Digit lot number XXXX

[2] Max peak reflow temperature of 260°C



Evaluation PCB

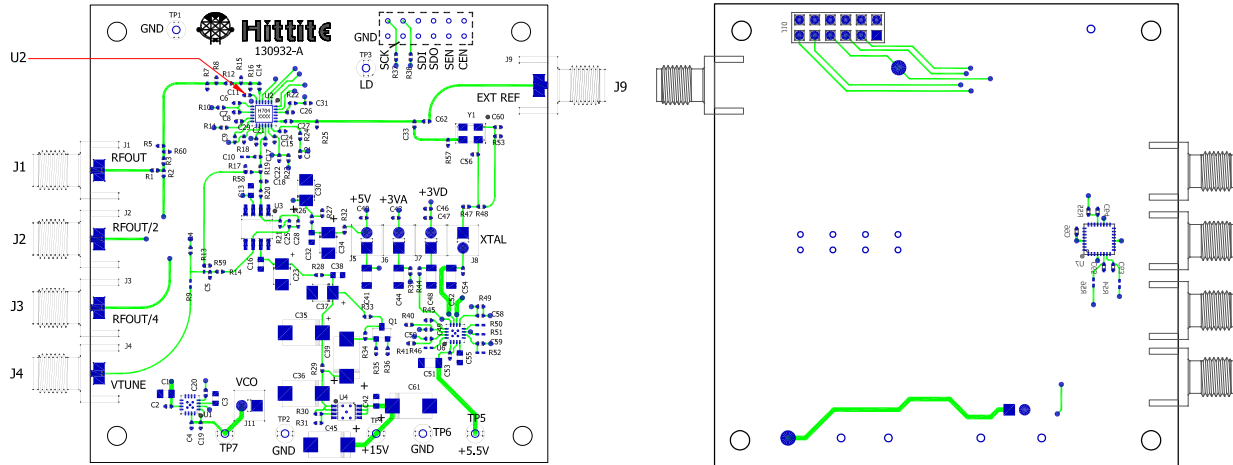

The circuit board used in the application should use RF circuit design techniques. Signal lines should have 50 Ohms impedance while the package ground leads and exposed paddle should be connected directly to the ground plane similar to that shown. A sufficient number of via holes should be used to connect the top and bottom ground planes. The evaluation circuit board shown is available from Hittite upon request.

Table 5. Evaluation Order Information

Item	Contents	Part Number
Evaluation Kit	HMC704LP4E Evaluation PCB USB Interface Board 6' USB A Male to USB B Female Cable CD ROM (Contains User Manual, Evaluation PCB Schematic, Evaluation Software, Hittite PLL Design Software)	129856-HMC704LP4E



Evaluation PCB Block Diagram

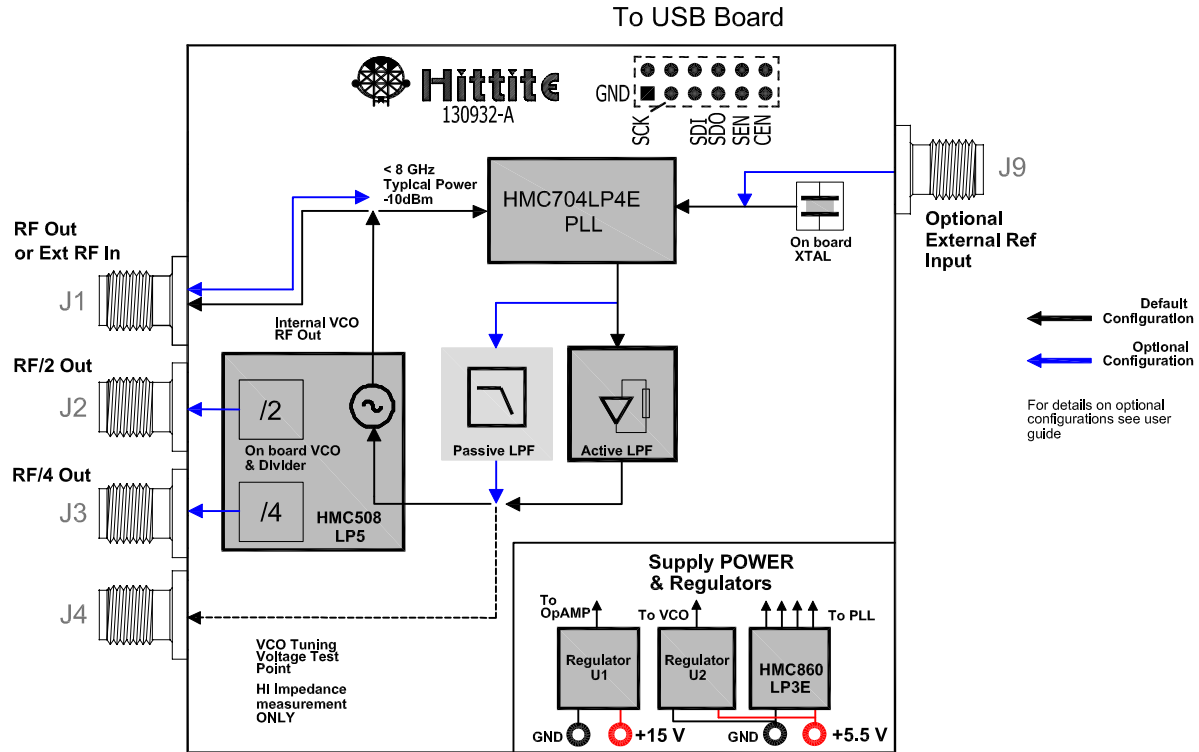

Evaluation PCB Schematic

To view [Evaluation PCB Schematic](http://www.hittite.com) please visit www.hittite.com and choose HMC704LP4E from “Search by Part Number” pull down menu to view the product splash page.

Theory of Operation

The PLL consists of the following functional blocks:

1. Reference Path Input Buffer and 'R' Divider
2. VCO Path Input Buffer, RF Divide-by-2 and Multi-Modulus 'N' Divider
3. $\Delta\Sigma$ Fractional Modulator
4. Phase Detector
5. Charge Pump
6. Main Serial Port
7. Lock Detect and Register Control
8. Auxiliary Output Serial Port
9. Power On Reset Circuit

External VCO

The PLL charge pump can operate with the charge pump supply as high as 5.2 Volts. The charge pump output at the varactor tuning port, normally can maintain low noise performance to within 500mV of ground or 800mV of the upper supply voltage.

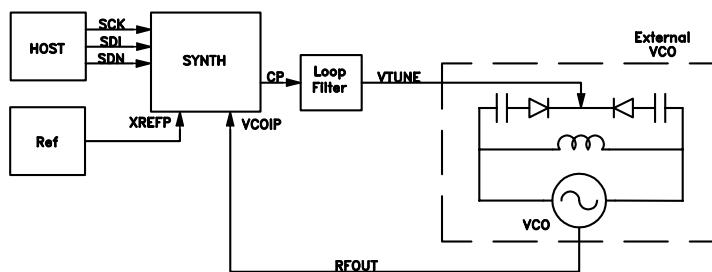

Figure 23. Synthesizer with External VCO

High Performance Low Spurious Operation

The HMC704LP4E has been designed for the best phase noise and low spurious content possible in an integrated PLL. Spurious signals in a PLL can occur in any mode of operation and can come from a number of sources.

Figure of Merit Noise Floor and Flicker Noise Models

The phase noise of an ideal phase locked oscillator is dependent upon a number of factors:

- a. Frequency of the VCO, and the Phase detector
- b. VCO Sensitivity, k_{vco} , VCO and Reference Oscillator phase noise profiles
- c. Charge Pump current, Loop Filter and Loop Bandwidth
- d. Mode of Operation: Integer, Fractional modulator style

The contributions of the PLL to the output phase noise can be characterized in terms of a Figure of Merit (FOM) for both the PLL noise floor and the PLL flicker (1/f) noise regions, as follows:



where:

Φ_p^2	Phase Noise Contribution of the PLL (rads ² /Hz)
f_o	Frequency of the VCO (Hz)
f_{pd}	Frequency of the Phase Detector (Hz)
f_m	Frequency offset from the carrier (Hz)
F_{po}	Figure of Merit (FOM) for the phase noise floor
F_{p1}	Figure of Merit (FOM) for the flicker noise region

PLL Phase Noise Contribution

$$\Phi_p^2(f_o, f_m, f_{pd}) = + \frac{F_{p1} f_o^2}{f_m} - \frac{F_{po} f_o^2}{f_{pd}} \quad (\text{EQ 1})$$

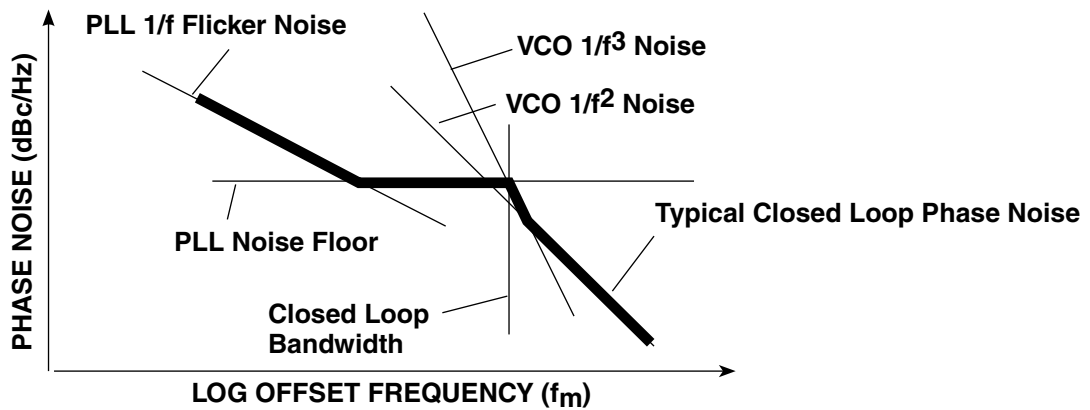

Figure 24. Figures of Merit Noise Models for the PLL

If the free running phase noise of the VCO is known, it may also be represented by a figure of merit for both $1/f^2$, F_{v2} , and the $1/f^3$, F_{v3} , regions.

VCO Phase Noise Contribution

$$\Phi_v^2(f_o, f_m) = \frac{F_{v2} f_o^2}{f_m^2} + \frac{F_{v3} f_o^2}{f_m^3} \quad (\text{EQ 2})$$

The Figures of Merit are essentially normalized noise parameters for both the PLL and VCO that can allow quick estimates of the performance levels of the PLL at the required VCO, offset and phase detector frequency. Normally, the PLL IC noise dominates inside the closed loop bandwidth of the PLL, and the VCO dominates outside the loop bandwidth at offsets far from the carrier. Hence a quick estimate of the closed loop performance of the PLL can be made by setting the loop bandwidth equal to the frequency where the PLL and free running phase noise are equal.

The Figure of Merit is also useful in estimating the noise parameters to be entered into a closed loop design tool such as Hittite PLL Design, which can give a much more accurate estimate of the closed loop phase noise and PLL loop filter component values.

Given an optimum loop design, the approximate closed loop performance is simply given by the minimum of the PLL and VCO noise contributions.



8 GHz FRACTIONAL-N PLL

PLL-VCO Noise

$$\Phi^2 = \min(\Phi_p^2, \Phi_v^2)$$

(EQ 3)

An example of the use of the FOM values to make a quick estimate of PLL performance: Estimate the phase noise of an 8GHz closed loop PLL with a 100MHz reference operating in Fractional Mode B with the VCO operating at 8GHz and the VCO divide by 2 port driving the PLL at 4GHz. Assume an HMC509 VCO has free running phase noise in the 1/f² region at 1MHz offset of -135dBc/Hz and phase noise in the 1/f³ region at 1kHz offset of -60dBc/Hz.

$F_{v1_dB} =$ -135 $+20 \cdot \log_{10}(1e6)$ $-20 \cdot \log_{10}(8e9)$ $= -213.1 \text{ dBc/Hz at 1Hz}$	$F_{v3_dB} =$ -60 $+30 \cdot \log_{10}(1e3)$ $-20 \cdot \log_{10}(8e9)$ $= -168 \text{ dBc/Hz at 1Hz}$	Free Running VCO PN at 1MHz offset PNoise normalized to 1Hz offset Pnoise normalized to 1Hz carrier VCO FOM
		Free Running VCO PN at 1kHz offset PNoise normalized to 1Hz offset Pnoise normalized to 1Hz carrier VCO Flicker FOM

We can see from [Figure 3](#) and [Figure 4](#) respectively that the PLL FOM floor and FOM flicker parameters in fractional Mode A:

$F_{po_dB} = -227 \text{ dBc/Hz at 1Hz}$
 $F_{p1_dB} = -266 \text{ dBc/Hz at 1Hz}$

Each of the Figure of Merit equations result in straight lines on a log-frequency plot. We can see in the example below the resulting

PLL floor at 8GHz = $F_{po_dB} + 20 \log_{10}(f_{vco}) - 10 \log_{10}(f_{pd}) = -227 + 198 - 80 = -109 \text{ dBc/Hz}$
 PLL Flicker at 1kHz = $F_{p1_dB} + 20 \log_{10}(f_{vco}) - 10 \log_{10}(f_m) = -266 + 198 - 30 = -98 \text{ dBc/Hz}$
 VCO at 1MHz = $F_{v1_dB} + 20 \log_{10}(f_{vco}) - 20 \log_{10}(f_m) = -213 + 198 - 120 = -135 \text{ dBc/Hz}$
 VCO flicker at 1kHz = $F_{v3_dB} + 20 \log_{10}(f_{vco}) - 30 \log_{10}(f_m) = -168 + 198 - 90 = -60 \text{ dBc/Hz}$

These four values help to visualize the main contributors to phase noise in the closed loop PLL. Each falls on a linear line on the log-frequency phase noise plot shown in [Figure 25](#).

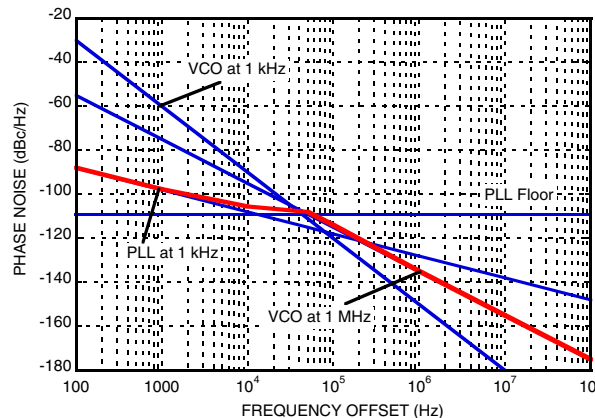

Figure 25. Example of Figure of Merit models at 8 GHz



It should be noted that actual phase noise near the corner frequency of the loop bandwidth is affected by loop parameters and one should use a more complete design tool such as Hittite PLL Design for better estimates of the phase noise performance. Noise models for each of the components in Hittite PLL Design can be derived from the FOM equations or can be provided by Hittite applications engineering.

Spurious Performance

Integer Operation

The VCO always operates at an integer multiple of the PD frequency in an integer PLL. In general spurious signals originating from an integer PLL can only occur at multiples of the PD frequency. These unwanted outputs are often simply referred to as reference sidebands.

Spurs unrelated to the reference frequency must originate from outside sources. External spurious sources can modulate the VCO indirectly through power supplies, ground, or output ports, or bypass the loop filter due to poor isolation of the filter. It can also simply add to the output of the PLL.

The HMC704LP4E has been designed and tested for ultra-low spurious performance. Reference spurious levels are typically below -100dBc with a well designed board layout. A regulator with low noise and high power supply rejection, such as the HMC860LP3E, is recommended to minimize external spurious sources.

Reference spurious levels of below -100dBc require superb board isolation of power supplies, isolation of the VCO from the digital switching of the PLL and isolation of the VCO load from the PLL. Typical board layout, regulator design, demo boards and application information are available for very low spurious operation. Operation with lower levels of isolation in the application circuit board, from those recommended by Hittite, can result in higher spurious levels.

Of course, if the application environment contains other interfering frequencies unrelated to the PD frequency, and if the application isolation from the board layout and regulation are insufficient, then the unwanted interfering frequencies will mix with the desired PLL output and cause additional spurs. The level of these spurs is dependant upon isolation and supply regulation or rejection (PSRR).

Fractional Operation

Unlike an integer PLL, spurious signals in a fractional PLL can occur due to the fact that the VCO operates at frequencies unrelated to the PD frequency. Hence intermodulation of the VCO and the PD harmonics can cause spurious sidebands. Spurious emissions are largest when the VCO operates very close to an integer multiple of the PD. When the VCO operates exactly at a harmonic of the PD then, no in-close mixing products are present.

Interference is always present at multiples of the PD frequency, f_{pd} , and the VCO frequency, f_{vco} . If the fractional mode of operation is used, the difference, Δ , between the VCO frequency and the nearest harmonic of the reference, will create what are referred to as integer boundary spurs. Depending upon the mode of operation of the PLL, higher order, lower power spurs may also occur at multiples of integer fractions (sub-harmonics) of the PD frequency. That is, fractional VCO frequencies which are near $nf_{pd} + f_{pd}d/m$, where n , d and m are all integers and $d < m$ (mathematicians refer to d/m as a rational number). We will refer to $f_{pd}d/m$ as an integer fraction. The denominator, m , is the order of the spurious product. Higher values of m produce smaller amplitude spurious at offsets of $m\Delta$ and usually when $m > 4$ spurs are very small or unmeasurable.

The worst case, in fractional mode, is when $d=0$, and the VCO frequency is offset from nf_{pd} by less than the loop bandwidth. This is the "in-band fractional boundary" case.

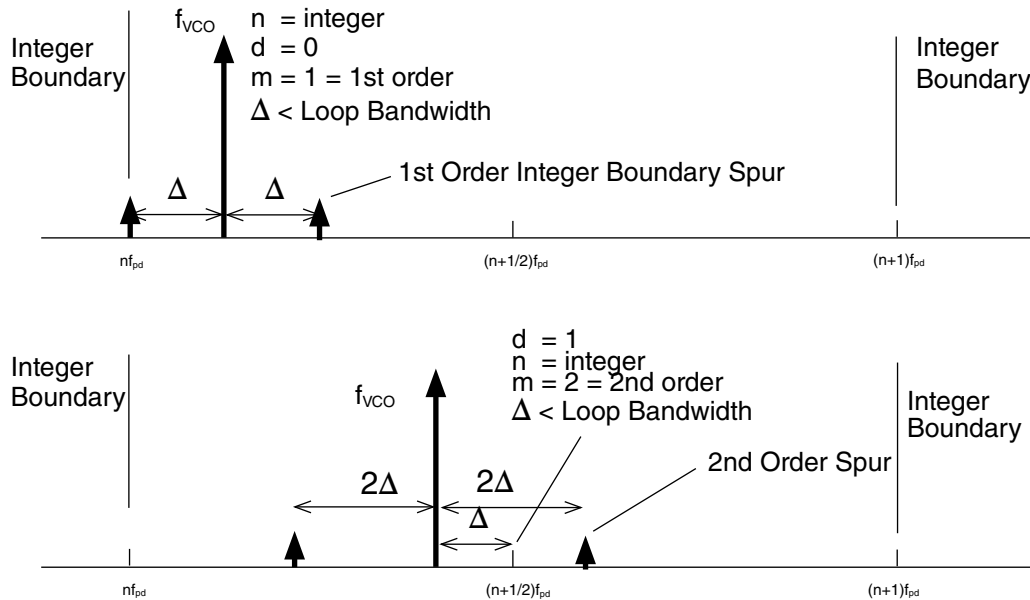

Figure 26. Fractional Spurious Example

Characterization of the levels and orders of these products is not unlike a mixer spur chart. Exact levels of the products are dependent upon isolation of the various PLL parts. Hittite can offer guidance about expected levels of spurious with our PLL and VCO application boards. Regulators with high power supply rejection ratios (PSRR) are recommended, especially in noisy applications.

When operating in fractional mode, charge pump and phase detector linearity is of paramount importance. Any non-linearity degrades phase noise and spurious performance. Phase detector linearity degrades when the phase error is very small and is operating back and forth between reference lead and VCO lead. To mitigate these non-linearities in fractional mode it is critical to operate the phase detector with some finite phase offset such that either the reference or VCO always leads. To provide a finite phase error, extra current sources can be enabled which provide a constant DC current path to VDD (VCO leads always) or ground (reference leads always). These current sources are called charge pump offset and they are controlled via ["Reg 09h"](#). The time offset at the phase detector should be $\sim 2.5\text{ns} + 4T_{PS}$, where T_{PS} is the RF period at the fractional prescaler input in nanoseconds (ie. after the optional fixed divide by 2). The specific level of charge pump offset current is determined by this time offset, the comparison frequency and the charge pump current and can be calculated from:

$$\text{Required CP Offset } (\mu\text{A}) = (2.5 \times 10^{-9} + 4T_{PS}) (\text{sec}) \times (F_{\text{comparison}}) (\text{Hz}) \times I_{CP} (\mu\text{A}) \quad (\text{EQ 4})$$

Operation with charge pump offset influences the required configuration of the Lock Detect function. Refer to the description of ["PD Window Based Lock Detect"](#) later in this document. Note that this calculation can be performed for the center frequency of the VCO, and does not need refinement for small differences (<25%) in center frequencies.

Another factor in the spectral performance in Fractional Mode is the choice of the Delta-Sigma Modulator mode. Mode A can offer better in-band spectral performance (inside the loop bandwidth) while Mode B offers better out of band performance. See ["Reg 06h"](#)[3:2] for DSM mode selection. Finally, all fractional PLLs create fractional spurs at some level. Hittite offers the lowest level fractional spurious in the industry in an integrated solution.

Reference Input Stage

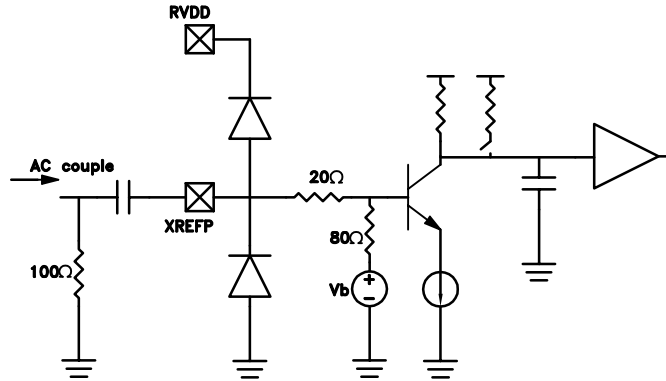

Figure 27. Reference Path Input Stage

The reference buffer provides the path from an external reference source (generally crystal based) to the R divider, and eventually to the phase detector. The buffer has two modes of operation. High Gain (recommended below 200MHz), and High frequency, for 200 to 350MHz operation. The buffer is internally DC biased, with 100 Ohm internal termination. For 50 Ohm match, an external 100 Ohm resistance to ground should be added, followed by an AC coupling capacitance (impedance < 1 Ohm), then to the XREFP pin of the part.

At low frequencies, a relatively square reference is recommended to keep the input slew rate high. At higher frequencies, a square or sinusoid can be used. The following table shows the recommended operating regions for different reference frequencies. If operating outside these regions the part will normally still operate, but with degraded performance.

Minimum pulse width at the reference buffer input is 2.5ns. For best spur performance when R = 1, the pulse width should be (2.5ns + 8Tps), where Tps is the period of the VCO at the prescaler input. When R > 1 minimum pulse width is 2.5ns.

Table 6. Reference Sensitivity Table

Frequency (MHz)	Square Input			Sinusoidal Input		
	Slew > 0.5V/ns	Recommended Swing (Vpp)		Recommended	Recommended Power Range (dBm)	
	Recommended	Min	Max		Min	Max
< 10	YES	0.6	2.5	x	x	x
10	YES	0.6	2.5	x	x	x
25	YES	0.6	2.5	ok	8	15
50	YES	0.6	2.5	YES	6	15
100	YES	0.6	2.5	YES	5	15
150	ok	0.9	2.5	YES	4	12
200	ok	1.2	2.5	YES	3	8
200 to 350	x	x	x	YES ¹	5	10

Note: For greater than 200MHz operation, use buffer in High Frequency Mode. Reg[8] bit 21 = 1

Input referred phase noise of the PLL when operating at 50MHz is between -150 and -156dBc/Hz at 10kHz offset depending upon the mode of operation. The input reference signal should be 10dB better than this floor to avoid degradation of the PLL noise contribution. It should be noted that such low levels are only necessary if the PLL is the dominant noise contributor and these levels are required for the system goals.

Ref Path 'R' Divider

The reference path "R" divider is based on a 14 bit counter and can divide input signals of up to 350MHz input by values from 1 to 16,383 and is controlled by "Reg 02h"[13:0]. The reference divider output may be viewed in test mode on the LD_SDO pin, by setting "Reg 0Fh"[4:0] = 9d.

RF Path

The RF path is shown in [Figure 28](#). This path features a low noise 8GHz RF input buffer followed by an 8GHz RF divide-by-2 with a selectable bypass. If the VCO input is below 4GHz the RF divide-by-2 should be by-passed for reduced power consumption and improved performance in fractional mode. The RF divide-by-2 is followed by the N divider, a 19 bit divider that can operate in either integer or fractional mode with up to 4GHz inputs. Finally the N divider is followed by the Phase Detector (PD), which has two inputs, the RF path from the VCO (V) and the reference path (R) from the crystal. The PD can operate at speeds up to 80MHz in fractional Mode A, 100MHz in fractional Mode B and 115MHz in integer mode.

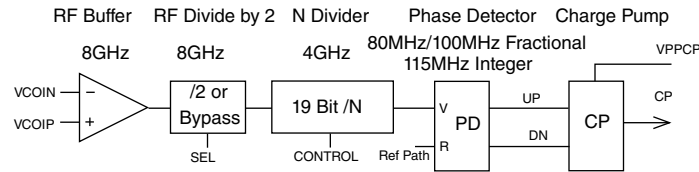

Figure 28. RF Path

RF Input Stage

The RF input stage provides the path from the external VCO to the phase detector via the RF or 'N' divider. The RF input path is rated to operate up to 8GHz across all conditions. The RF input stage is a differential common emitter stage with internal DC bias, and is protected by ESD diodes as shown in [Figure 29](#). This input is not matched to 50 Ohms. A 50 Ohm resistor placed across the inputs can be used if desired. In most applications the input is used single-ended into either the VCOIP or VCOIN pin with the other input connected to ground through a DC blocking capacitor. The preferred input level for best spectral performance is -10dBm nominally.

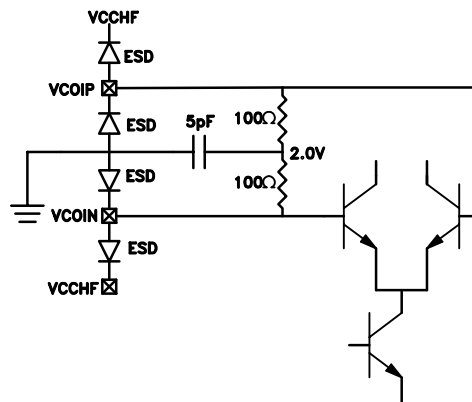

Figure 29. RF Input Stage



RF Path 'N' Divider

The main RF path 'N' divider is capable of divide ratios anywhere between 2^{19-1} (524,287) and 16. This divider for example could divide a 4GHz input to a PD frequency anywhere between its maximum output limit of 115MHz to as low as 7.6kHz. The 'N' divider output may be viewed in test mode on LD_SDO by setting "[Reg 0Fh](#)"[4:0] = 10d. When operating in fractional mode the N divider can change by up to +/-4 from the average value. Hence the selected divide ratio in fractional mode is restricted to values between 2^{19-5} (524,283) and 20.

If the VCO input is above 4GHz then the 8GHz fixed RF divide-by-2 should be used, "[Reg 08h](#)"[19] = 1. In this case the total division range is restricted to even numbers over the range $2*(2^{19-5})$ (1,048,566) to 40.

Charge Pump and Phase Detector

The Phase Detector or PD has two inputs, one from the reference path divider and one from the RF path divider. When in lock these two inputs are at the same average frequency and are fixed at a constant average phase offset with respect to each other. We refer to the frequency of operation of the PD as f_{pd} . Most formula related to step size, delta-sigma modulation, timers etc., are functions of the operating frequency of the PD, f_{pd} is sometimes referred to as the comparison frequency of the PD.

The PD compares the phase of the RF path signal with that of the reference path signal and controls the charge pump output current as a linear function of the phase difference between the two signals. The output current varies in a linear fashion over nearly $\pm 2\pi$ radians (± 360) of input phase difference.

Phase Detector and Charge Pump Functions

Phase detector register "[Reg 08h](#)" allows manual access to control special phase detector features.

"[Reg 0Bh](#)"[2:0] allows fine tuning of the PD reset path delay. This adjustment can be used to improve performance at very high PD rates. Most often this register is set to the recommended value only.

"[Reg 06h](#)"[5] and [6] enables the PD UP and DN outputs respectively. Disabling prevents the charge pump from pumping up or down respectively and effectively tri-states the charge pump while leaving all other functions operating internally.

CP Force UP "[Reg 08h](#)"[9] and CP Force DN "[Reg 00h](#)"[10] allows the charge pump to be forced up or down respectively. This will force the VCO to the ends of the tuning range which can be useful for testing of the VCO.

PD Force Mid "[Reg 0Bh](#)"[11] will disable the charge pump current sources and place a voltage source on the loop filter at approximately $V_{PPCP}/2$. If a passive filter is used this will set the VCO to the mid-voltage tuning point which can be useful for testing of the VCO.

"[Reg 0Bh](#)"[21:7] control other aspects of the phase detector operation and should be set to recommended values.

PLL Jitter

The standard deviation of the arrival time of the VCO signal, or the jitter, may be estimated with a simple approximation if we assume that the locked VCO has a constant phase noise, $\Phi^2(f_0)$, at offsets less than the loop 3dB bandwidth and a 20dB per decade roll off at greater offsets. The simple locked VCO phase noise approximation is shown on the left of [Figure 30](#).

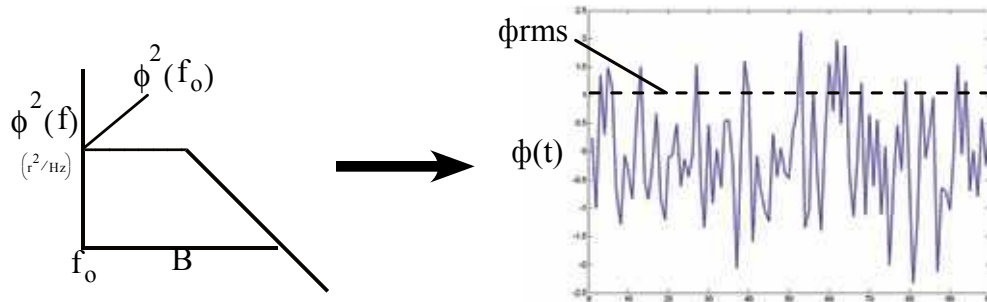

Figure 30. Synthesizer Phase Noise and Jitter

With this simplification the total integrated VCO phase noise, Φ_v^2 , in rads^2 is given by

$$\Phi_v^2 = \Phi^2(f_0) B \pi \quad (\text{EQ 5})$$

where
 $\Phi^2(f_0)$ is the single sideband phase noise in rads^2/Hz inside the loop bandwidth, and
 B is the 3dB corner frequency of the closed loop PLL

The integrated phase noise at the phase detector, Φ_{pd}^2 , is just scaled by N^2 ie. $\Phi_{pd}^2 = \frac{\Phi_v^2}{N^2}$

The rms phase jitter of the VCO (Φ_v) in rads, is just the square root of the phase noise integral.

Since the simple integral of (EQ 5) is just a product of constants, we can easily do the integral in the log domain. For example if the phase noise inside the loop is $-110\text{dBc}/\text{Hz}$ at 10kHz offset and the loop bandwidth is 100kHz , and the division ratio is 100, then the integrated phase noise at the phase detector, in dB, is given by;

$$\Phi_{pd}^2 \text{ dB} = 10 \log(\Phi^2(f_0) \beta \pi / N^2) = -110 + 5 + 50 - 40 = -95 \text{ dB rads}, \text{ or equivalently } \Phi = 10^{-95/20} = 18 \text{ urads} = 1 \text{ milli-degrees rms.}$$

While the phase noise reduces by a factor of $20 \log N$ after division to the reference, due to the increased period of the PD reference signal, the jitter is constant.

$$\text{The rms jitter from the phase noise is then given by } T_{jpn} = T_{pd} \Phi_{pd} / 2\pi$$

In this example if the PD reference was 50MHz , $T_{pd} = 20\text{nsec}$, and hence $T_{jpn} = 56 \text{ femto-sec.}$

PD Window Based Lock Detect

Lock Detect Enable "[Reg 0Bh](#)"[3]=1 is a global enable for all lock detect functions.

The window based Lock Detect circuit effectively measures the difference between the arrival of the reference and the divided VCO signals at the PD. The arrival time difference must consistently be less than the Lock Detect window length, to declare lock. Either signal may arrive first, only the difference in arrival times is counted.



Analog Window Lock Detect

The lock detect window may be generated by either an analog circuit or a digital one-shot circuit. Clearing “Reg 07h”[6]=0 will result in a fixed, analog, nominal 10nsec window, as shown in Figure 31. The analog window cannot be used if the PD rate is very high, for example near 100MHz, or if the charge pump offset current results in an offset larger than 7nsec.

For example a 25MHz PD rate with a 1mA charge pump setting (“Reg 09h”[6:0]=“Reg 09h”[13:7]= 50d) and a -400uA offset current (“Reg 09h”[20:14]=80d), would have a phase offset of about $400/1000 = 40\%$ of the PD period or about 16nsec. In such an extreme case the divided VCO would arrive 16ns after the PD reference, and would always arrive outside of the 10nsec lock detect window. In such a case the lock detect circuit would always read unlocked, even though the VCO might be locked. The charge pump current, reference period, charge pump offset current, and lock detect window are related.

Digital Window Lock Detect

Setting “Reg 07h”[6]=1 will result in a variable length lock detect window based upon the internal digital timer. The one shot timer period is controlled by “Reg 07h”[11:10]. The resulting lock detect window period is then generated by the number of timer periods defined in “Reg 07h”[9:7].

Declaration of Lock

“Reg 07h”[2:0] defines the number of consecutive counts of the divided VCO that must land inside the lock detect window to declare lock. If for example we set “Reg 07h”[2:0]=5 then the VCO arrival would have to occur inside the window 2048 times in a row to be declared locked, which would result in a Lock Detect Flag high. A single occurrence outside of the window will result in an out of lock, i.e. Lock Detect Flag low. Once low, the Lock Detect Flag will stay low until the $lkd_wincnt_max = 2048$ condition is met again.

The Lock Detect Flag status is always readable in “Reg 12h”[1]. Lock Detect status is also output to the LD_SDO pin if “Reg 0Fh”[4:0]=1, “Reg 0Fh”[6]=1 and “Reg 0Fh”[7]=1. Clearing “Reg 0Fh”[6]=0 will display the Lock Detect Flag on LD_SDO except when a serial port read is requested, in which case the pin reverts temporarily to the Serial Data Out pin and returns to the Lock Detect Flag after the read is completed. Timing of the Lock Detect function is shown in Figure 31 and Figure 32.

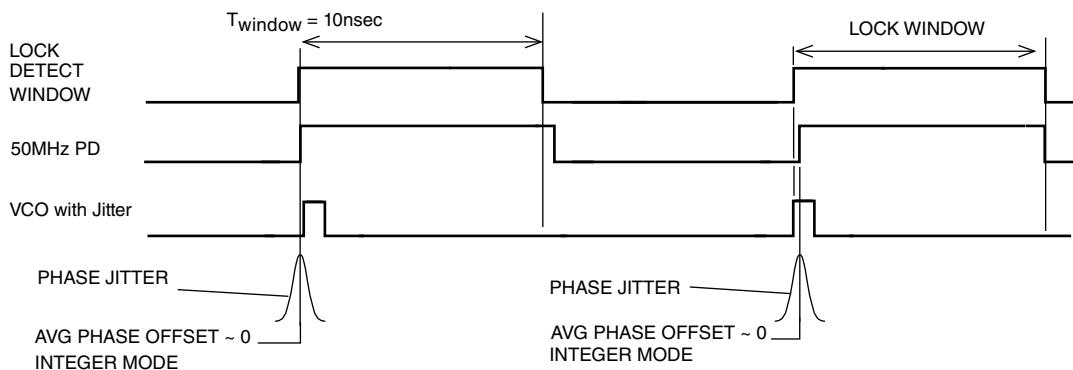

Figure 31. Normal Lock Detect Window - Integer Mode, Zero Offset

Lock Detect Operation with Phase Offset

When operating in fractional mode the linearity of the charge pump and phase detector are much more critical than in integer mode. The phase detector linearity degrades when operated with zero phase offset. Hence in fractional mode it is necessary to offset the phase of the reference and VCO at the phase detector. In such a case, for example with an offset delay, as shown in Figure 32, the VCO arrival may always occur after the reference. The lock detect circuit window may need to be adjusted to allow for the delay being used, if the delay is large.

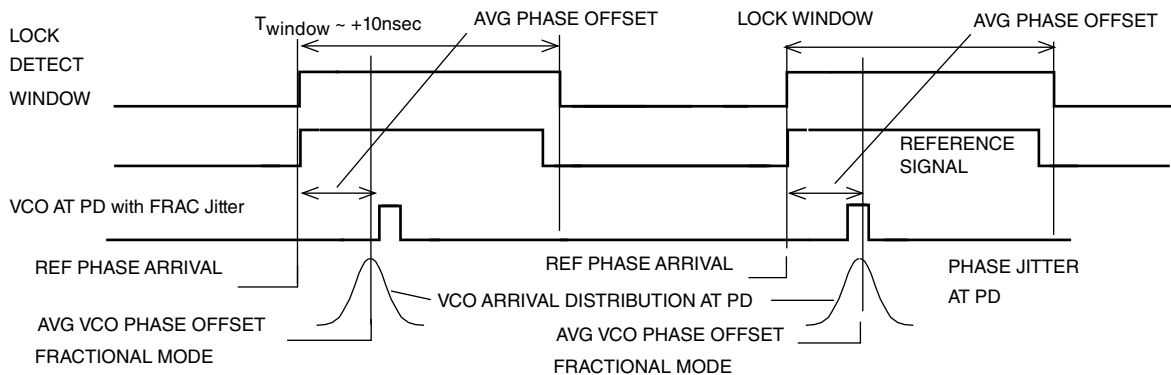

Figure 32. Lock Detect Window - Fractional Mode with Offset

In integer mode, 0 offset is recommended. In fractional mode, the time offset should be set to $\sim 2.5\text{ns} + 4T_{ps}$, where T_{ps} is the RF period at the fractional prescaler input (i.e. after the optional fixed divide by 2). Refer to the Fractional Operation section for further details about calculating charge pump offset currents

Digital Lock Detect with Digital Window Example

Typical Digital Lock detect window widths are shown in Table 7. Lock Detect windows typically vary +/-10% vs voltage and +/-15% over -40C to +85C.

Table 7. Typical Digital Lock Detect Window

LD Timer Speed Reg07[11:10]	Digital Lock Detect Window Nominal Value +/-25% (nsec)								
Fastest 00	6.5	8.0	11.0	17	29	53	100	195	
01	7.0	8.9	12.8	21	36	68	130	255	
10	7.1	9.2	13.3	22	38	72	138	272	
Slowest 11	7.6	10.2	15.4	26	47	88	172	338	
LD Timer Divider Setting Reg07[9:7]	0	1	2	3	4	5	6	7	
LD Timer Divider Value	0.5	1	2	4	8	16	32	64	

As an example if we operate in fractional mode, with a 50MHz PD, a 2700 MHz VCO and a Charge pump gain of 2mA ("Reg 09h"), based on the previous example, we should set the DC phase offset near $2.5\text{ns} + 4 \times 370\text{ps} = 4\text{ns}$, or 20% of the 20ns reference period. It becomes a larger proportion with increasing f_{pd} . The offset current is therefore $20\% \times 2\text{mA} = 400\mu\text{A}$. The polarity of the offset should be chosen so that the VCO lags the reference for the most consistent results. For non-inverting /inverting loop filter configurations, we recommend down/up offsets, respectively.



Given a DC phase offset as described in the above example, when in lock, the divided VCO will arrive at the PD about 4nsec after the divided Reference. The Lock Detect Window always starts on the arrival of the first signal at the PD, in this case the Reference. The Lock Detect window must be longer than $4\text{ns} + 4T_{\text{ps}}$ and shorter than the period of the PD, in this example, 20nsec.

A comfortable solution of 8.9ns with timer speed set at `"Reg 07h"[11:10]=1` and Timer divider `"Reg 07h"[9:7]=1` works well for the example PD frequency and charge pump offset setting.

Tolerance on the window is +25% at +85C, -25% at -40C. Here 8.9ns nominal window may extend by +25% at +85C to 11.1ns, which is fine for a PD period of 20ns. Also the minimum window may shrink by 25% to 6.7ns at -40C, which again works well for the DC offset of 4.0ns (worst case instantaneous phase offset of 5.5ns).

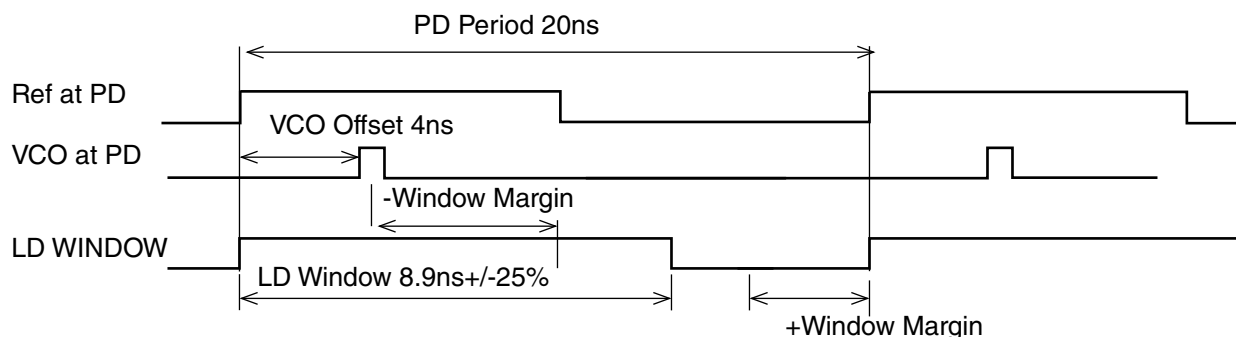

Figure 33. Lock Detect Window Example with 50MHz PD and 4ns VCO Offset

There is always a good solution for the lock detect window for a given operating point. The user should understand however that one solution does not fit all operating points. If charge pump offset or PD frequency are changed significantly then the lock detect window may need to be adjusted.

Cycle Slip Prevention (CSP)

When changing frequency and the VCO is not yet locked to the reference, the instantaneous frequencies of the two PD inputs are different, and the phase difference of the two inputs at the PD varies rapidly over a range much greater than $\pm 2\pi$ radians. Since the gain of the PD varies linearly with phase up to $\pm 2\pi$, the gain of a conventional PD will cycle from high gain, when the phase difference approaches a multiple of 2π , to low gain, when the phase difference is slightly larger than 0 radians. The output current from the charge pump will cycle from maximum to minimum even though the VCO has not yet reached its final frequency.

The charge on the loop filter small cap may actually discharge slightly during the low gain portion of the cycle. This can make the VCO frequency actually reverse temporarily during locking. This phenomenon is known as cycle slipping. Cycle slipping causes the pull-in rate during the locking phase to vary cyclically. Cycle Slipping increases the time to lock to a value much greater than that predicted by normal small signal Laplace analysis.

The PLL PD features an ability to reduce cycle slipping during acquisition. The Cycle Slip Prevention (CSP) feature increases the PD gain during large phase errors. The specific phase error that triggers the momentary increase in PD gain is set via `"Reg 0Bh"[8:7]`.



PD Polarity

“Reg 0Bh”[4]=0 sets the phase detector polarity for use with a passive loop filter together with a VCO with a positive tuning slope (increasing tuning voltage increases VCO frequency).

“Reg 0Bh”[4]=1 inverts the phase detector polarity. This is most often used if an inverting op-amp is used in an active loop filter together with a VCO with a positive tuning slope.

Charge Pump Tri-state

“Reg 0Bh”[5]=“Reg 0Bh”[6]=0 tri-states the charge pump. This effectively freezes charge on the loop filter and allows the VCO to run open loop.

Charge Pump Gain

“Reg 09h”[6:0] and “Reg 09h”[13:7] program current gain settings for the charge pump. Pump ranges can be set from 0uA to 2.54mA in 20uA steps. Charge pump gain affects the loop bandwidth. The product of VCO gain (K_{vco}) and charge pump gain (K_{cp}) can be held constant for VCO's that have a wide ranging K_{vco} by adjusting the charge pump gain. This compensation helps to keep the loop bandwidth constant.

In addition to the normal CP current as described above, there is also an extra output source of current that offers improved noise performance. HiK_{cp} provides an output current that is proportional to the loop filter voltage. This being the case HiK_{cp} should only be operated with active op-amp loop filters that define the voltage as seen by the charge pump pin. With 2.5V as observed at the charge pump pin, the HiK_{cp} current is 3.5mA.

There are several configurations that could be used with the HiK_{cp} feature. For lowest noise, HiK_{cp} could be used without the normal charge pump current (the charge pump current would be set to 0). In this case, the loop filter would be designed with 3.5mA as the effective charge pump current.

Another possible configuration is to operate with both the HiK_{cp} and normal charge pump current sources. In this case the effective charge pump current would be 3.5mA + programmed normal charge pump current which could offer a maximum of 6mA.

With passive loop filters the voltage seen by the charge pump pin will vary which would cause the HiK_{cp} current to vary widely. As such, HiK_{cp} should not be used on passive loop filter implementations.

A simplified diagram of the charge pump is shown in [Figure 34](#). The current gain of the pump in Amps/radian is equal to the gain setting of this register divided by 2π .

Charge Pump Offset

“Reg 09h”[20:14] controls the charge pump current offsets. “Reg 09h”[21] and “Reg 09h”[22] enable the UP and DN offset currents respectively. Normally only one is used at a time. As mentioned earlier charge pump offsets affect fractional mode linearity and the Lock Detect window selection.

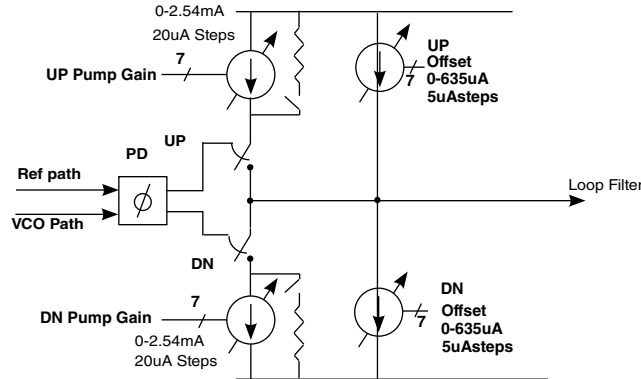

Figure 34. Charge Pump Gain and Offset Control - Reg09h

Frequency Tuning

The HMC704LP4E Fractional-N PLL can operate in either integer mode, or 3 different fractional modes.

Integer Mode: Delta Sigma modulator is disabled., ["Reg 06h"](#)[11]=0, ["Reg 06h"](#)[7]=1

Fractional Modes: delta sigma modulator is enabled., ["Reg 06h"](#)[11]=1, ["Reg 06h"](#)[7]=0

Mode A: provides better phase noise performance inside the loop bandwidth, worse outside;

Mode B : higher phase noise inside the loop bandwidth, better outside;

Exact Frequency Mode: Must be in Mode B. Provides zero frequency error;

Frequency programming and mode control is described below.

Frequency of VCO

$$f_{vco} = 2^d \left[\frac{f_{xtal}}{R} N_{int} + \frac{f_{xtal} \cdot N_{frac}}{R \cdot 2^{24}} \right] \approx 2^d [f_{int} \quad f_{frac}] \quad (EQ 6)$$

where

N_{int} integer division ratio, ["Reg 03h"](#),
 Integer Mode : an integer number between 16 and $2^{19}-1$
 Fractional Mode : an integer number between 20 and $2^{19}-5$

N_{frac} fractional part, a number from 0 to $2^{24}-1$, ["Reg 04h"](#)

d Divide by 2 for operation > 4GHz, ["Reg 08h"](#)[19] = 1, < 4GHz = 0

R Reference path division ratio, a number from 1 to 2^{14} , ["Reg 02h"](#)

f_{xtal} Frequency of the reference oscillator input

f_{PD} PD operating frequency, f_{xtal}/R

As an example for fractional operation at 2.3GHz + 2.98Hz:

- $f_{xtal} = 50\text{MHz}$
- $R = 1$
- $f_{ref} = 50\text{MHz}$
- $N_{int} = 46$
- $N_{frac} = 1$
- $d = 0$

$$f_{vco} = 2^0 \left[\frac{50 \times 10^6}{1} 46 + \frac{50 \times 10^6 \cdot 1}{1 \cdot 2^{24}} \right] = 2.3\text{GHz} \quad 2.98\text{Hz} \quad (EQ 7)$$



In this example the output frequency of 2,300,000,002.98Hz is achieved by programming the 16 bit binary value of 46d = 002Eh = 0000 0000 0010 1110 into dsm_intg.

Similarly the 24 bit binary value of the fractional word is written into dsm_frac,

1d = 000 001h = 0000 0000 0000 0000 0000 0001

Example 2: Set the output to 7.650 025 GHz using a 100MHz reference, R=2.

Here, output is greater than 4GHz, so we enable the internal divide by 2, d = 1. Find the nearest integer value N_{int} . $N_{int} = 76$, $2f_{int} = 7.600\ 000\text{GHz}$

This leaves the fractional part to be $2f_{frac} = 50.025\text{MHz}$

$$N_{frac} = \frac{2^{24} \cdot R \cdot f_{frac}}{2^d f_{xtal}} = \frac{2^{24} \cdot 2 \cdot 50.025 \times 10^6}{2 \cdot 100 \times 10^6} = 8392802.3 \quad (\text{EQ 8})$$

Since N_{frac} must be an integer number, we round it to 8,392,802, and the actual VCO frequency will be 7,650,024,998.19 Hz, an error of -1.81Hz or about 2 parts in 2-10.

Here we program the 16 bit $N_{int} = \text{"Reg 04h"} = 76d = 4Ch = 0000\ 0000\ 0100\ 1100$ and the 24 bit $N_{frac} = 8,392,802d = 801062h = 1000\ 0000\ 0001\ 0000\ 0110\ 0010$

In addition to the above frequency programming words, the fractional mode must be enabled using the frac register. Other DSM configuration registers should be set to the recommended values supplied with the product evaluation board or available from applications support.

Exact Frequency Mode

The absolute frequency precision of a fractional frequency PLLs is normally limited by the number of bits in the fractional modulator. For example a 24 bit fractional modulator has frequency resolution set by the phase detector (PD) comparison rate divided by 2^{24} . In the case of a 50MHz PD rate, this would be approximately 2.98 Hz, or 0.0596 ppm.

In some applications it is necessary to have exact frequency steps, and even an error of 3Hz cannot be tolerated. In some fractional PLLs it is necessary to shorten the length of the accumulator (the denominator or the modulus) to accommodate the exact period of the step size. The shortened accumulator often leads to very high spurious levels at multiples of the channel spacing, $f_{step} = f_{PD}/\text{Modulus}$. For example 200kHz channel steps with a 10MHz PD rate requires a modulus of just 50. The HMC method achieves the exact frequency step size while using the full 24 bit modulus, thus achieving exact frequency steps with very low spurious and a high comparison rate, which maintains excellent phase noise.

Exact frequency steps can be achieved only when the PD rate and the desired frequency step size are related by an integer multiple. More precisely, the greatest common divisor, (GCD) of the PD rate and the desired frequency step size must be an integer, and that integer must be less than $2^{14}-1$ or 16,383.

As an example suppose that we want to achieve:

- exact channel step size of $f_{step} = 100\text{kHz}$.
- Reference Crystal $f_{xtal} = 61.44\text{MHz}$
- Phase Detector (PD) Rate $f_{pd} = 61.44\text{MHz}$
- Channel 1 Frequency, $f_{vco}(\text{CH1}) = 2000.200\ \text{MHz}$



Proceed as follows:

- a. Calculate the GCD of the PD Rate, f_{pd} , and the step size, f_{step} , $GCD(61.44\text{MHz}, 100\text{kHz}) = f_{gcd} = 20\text{kHz}$ (same value for all channels)
- b. Set the Exact Frequency Register value, **"Reg 0Ch"** = $f_{pd}/f_{gcd} = 61.44\text{MHz}/20\text{kHz} = 3072d = C00h$ (same value is used for all channels)
- c. Calculate the integer register setting for the channel, **"Reg 03h"** = $N_{int} = f_{vco}/f_{pd} = \text{floor}(2000.2\text{MHz}/61.44\text{MHz}) = 32d = 20h$ (Note: floor = round down to nearest integer).
- d. Calculate the equivalent integer boundary frequency, $f_{int} = N_{int} * f_{pd} = 1966.080\text{MHz}$.
- e. Calculate the fractional register setting for the channel, **"Reg 04h"** = $N_{frac} = 2^{24}(f_{vco} - f_{int})/f_{pd} = \text{ceiling}(224 * (2000.2 - 1966.08)/61.44) = 9317035d = 8E2AABh$. It is important that this parameter be rounded up (hence the 'ceiling' function).

The fractional value is programmed for each new channel. The integer value is only programmed initially and then only if the output crosses an integer boundary.

Seed Register and AutoSeed Mode

The start phase of the fractional modulator digital phase accumulator (DPA) may be set to one of four possible default values via the seed register **"Reg 06h"**[1:0]. If autoseed **"Reg 06h"**[8] is set, then the PLL will automatically reload the start phase from **"Reg 06h"**[1:0] into the DPA every time a new fractional frequency is selected. If autoseed is not set, then the PLL will start new fractional frequencies with the value left in the DPA from the last frequency. Hence the start phase will effectively be random. Certain zero or binary seed values may cause spurious energy correlation at specific frequencies. Correlated spurs are advantageous only in very special cases where the spurious are known to be far out of band and are removed in the loop filter. For most cases a pseudo-random seed setting (**"Reg 06h"**[1:0] = 2 or 3) is recommended. Further, since the autoseed always starts the accumulators at the same place, performance is repeatable if autoseed is used. **"Reg 06h"**[1:0] = 2 is recommended.

Power on Reset

The HMC704LP4E features a hardware Power on Reset (POR) on the digital supply DVDD. All chip registers will be reset to default states approximately 250us after power up of DVDD. Once the supply is fully up, if the power supply then drops below 0.5V the digital portion will reset.

Power Down Mode

Hardware Power Down

Chip enable may be controlled from the hardware CEN pin 23, or it may be controlled from the serial port. **"Reg 01h"**[0] = 1 assigns control to the CEN pin. **"Reg 01h"**[0] = 0 assigns control to the serial port **"Reg 01h"**[1]. For hardware test reasons or some special applications it is possible to force certain blocks to remain on inside the chip, even if the chip is disabled. See the register **"Reg 01h"** description for more details.

Chip Identification

Version information may be read from the PLL by reading the content of chip_ID in **"Reg 00h"**.

General Purpose Output (GPO) Pin

The PLL features a General Purpose Output (GPO) on the LD_SDO pin. GPO registers are described in “Reg 0Fh”. The GPO is a flexible interface that supports a number of different functions and real time test waveforms. The phase noise performance at this output is poor and uncharacterized. The GPO output should not be toggling during normal operation otherwise spectral performance may degrade. To use the GPO in HMC SPI mode, bit “Reg 0Fh” [7] must be set to 1.

External VCO, 4.2V Tuning, Passive Filter

The HMC704LP4E is targeted for high performance applications with an external VCO. The PLL charge pump has been designed to work directly with VCOs that can be tuned nominally over 1.0 to 4.0 Volts on the varactor tuning port with a +5V charge pump supply voltage. Slightly wider ranges are possible with a +5.2V charge pump supply or with slightly degraded performance. Hittite HITT-PLL design software is available to design passive loop filters driven directly from the PLL charge pump.

External VCO, High Voltage Tuning, Active Filter

Optionally an external op-amp may be used to support VCOs requiring higher voltage tuning ranges. Hittite’s HITT-PLL design software is available to design active loop filters with external op-amps. Various filter configurations are supported.

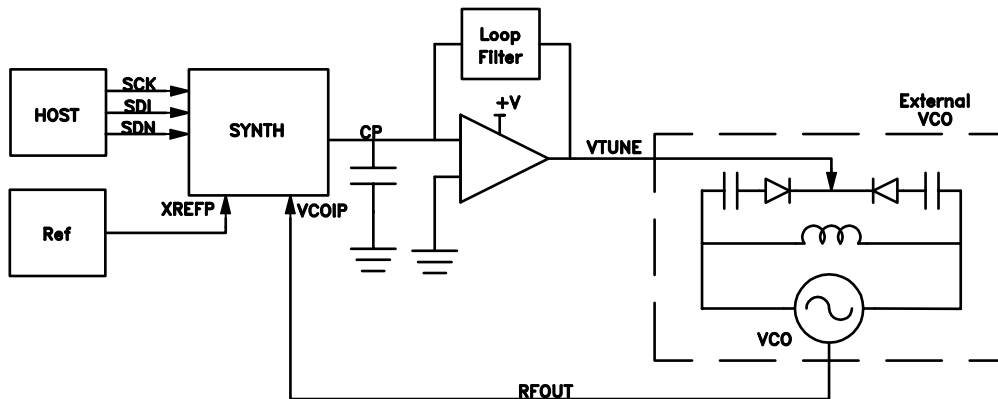

Figure 35. Synthesizer with Active Loop Filter and Conventional External VCO

MAIN SERIAL PORT

Serial Port Modes of Operation

The HMC PLL-VCO serial port interface can operate in two different modes of operation.

- a. HMC Mode (HMC Legacy Mode) - Single slave per HMC SPI Bus.
- b. Open Mode - Up to 8 slaves per HMC SPI Bus. The HMC5675ALP4E only uses 5 bits of address space.

Both protocols support 5 bits of register address space. HMC Mode can support up to 6 bits of register address but, is restricted to 5 bits when compatibility with Open Mode is offered.



Register 0 Modes

Register 0 has a dedicated function in each mode. Open Mode allows wider compatibility with other manufacturers SPI protocols.

Table 8. Register 0 Comparison - Single vs Multi-User Modes

	Single User HMC Mode	Single Or Multi-User Open Mode
READ	Chip ID 24 Bits	Chip ID 24Bits
WRITE	Soft Reset, General Strobes	Read Address [4:0] Soft reset [5] General Strobes [24:6]

Serial Port Mode Decision after Power-On Reset

On power up, both types of modes are active and listening. All digital IO must be low at power-up.

A decision to select the desired Serial Port mode (protocol) is made on the first occurrence of SEN or SCLK , after which the Serial Port mode is fixed and only changeable by a power down.

- a. If a rising edge on SEN is detected first HMC Mode is selected.
- b. If a rising edge on SCLK is detected first Open mode is selected.

Serial Port HMC Mode - Single PLL

HMC Mode (Legacy Mode) serial port operation can only address and communicate with a single PLL, and is compatible with most HMC PLLs and PLLs with integrated VCOS.

The HMC Mode protocol for the serial port is designed for a 4 wire interface with a fixed protocol featuring

- a. 1 Read/Write bit
- b. 6 Address bits
- c. 24 data bits

Serial Port Open Mode

The Serial Port Open Mode features:

- a. Compatibility with general serial port protocols that use a shift and strobe approach to communication.
- b. Compatible with HMC multi-Chip solutions, useful to address multiple chips of various types from a single serial port bus.

The HMC Open Mode protocol has the following general features:

- a. 3 bit chip address, can address up to 8 devices connected to the serial bus
- b. Wide compatibility with multiple protocols from multiple vendors
- c. Simultaneous Write/Read during the SPI cycle
- d. 5 bit register address space
- e. 3 wire for Write Only capability, 4 wire for Read/Write capability.

HMC RF PLLs with integrated VCOs also support HMC Open Mode. HMC700, HMC701, HMC702 and some generations of microwave PLLs with integrated VCOs do not support Open Mode.

Typical HMC Open Mode serial port operation can be run with SCLK at speeds up to 50MHz.

Serial Port HMC Mode

Typical serial port HMC Mode operation can be run with SCLK at speeds up to 50MHz.

HMC Mode - Serial Port WRITE Operation

AVDD = DVDD = 3.3V +/-10%, AGND = DGND = 0V

Table 9. SPI HMC Mode - Write Timing Characteristics

Parameter	Conditions	Min.	Typ.	Max.	Units
t ₁	SEN to SCLK setup time	8			nsec
t ₂	SDI to SCLK setup time	3			nsec
t ₃	SCLK to SDI hold time	3			nsec
t ₄	SEN low duration	20			nsec
	Max SPI Clock Frequency		50		MHz

A typical HMC Mode WRITE cycle is shown in [Figure 36](#).

- The Master (host) both asserts SEN (Serial Port Enable) and clears SDI to indicate a WRITE cycle, followed by a rising edge of SCLK.
- The slave (PLL) reads SDI on the 1st rising edge of SCLK after SEN. SDI low indicates a Write cycle (/WR).
- Host places the six address bits on the next six falling edges of SCLK, MSB first.
- Slave registers the address bits in the next six rising edges of SCLK (2-7).
- Host places the 24 data bits on the next 24 falling edges of SCLK, MSB first.
- Slave registers the data bits on the next 24 rising edges of SCLK (8-31).
- SEN is cleared on the 32nd falling edge of SCLK.
- The 32nd falling edge of SCLK completes the cycle.

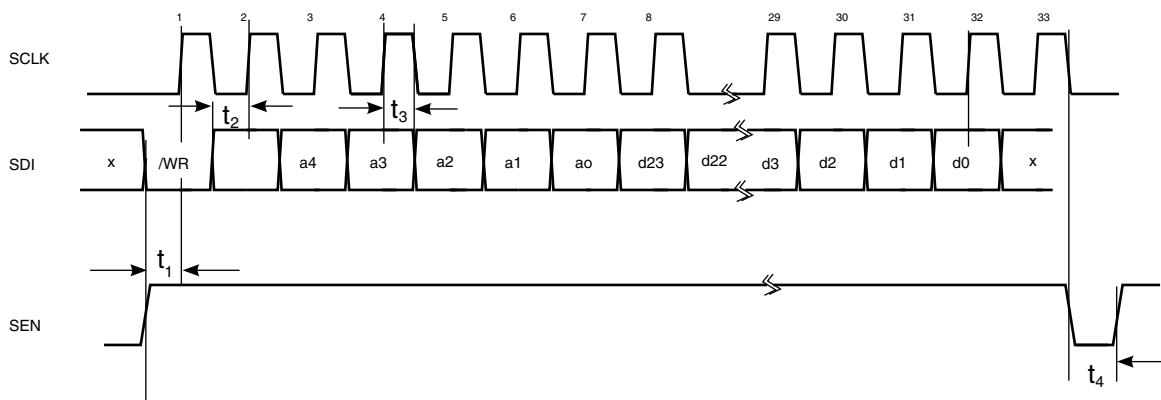

Figure 36. Serial Port Timing Diagram - HMC Mode WRITE



HMC Mode - Serial Port READ Operation

A typical HMC Mode READ cycle is shown in [Figure 37](#).

- a. The Master (host) asserts both SEN (Serial Port Enable) and SDI to indicate a READ cycle, followed by a rising edge SCLK. Note: The Lock Detect (LD) function is usually multiplexed onto the LD_SDO pin. It is suggested that LD only be considered valid when SEN is low. In fact LD will not toggle until the first active data bit toggles on LD_SDO, and will be restored immediately after the trailing edge of the LSB of serial data out as shown in [Figure 37](#).
- b. The slave (PLL) reads SDI on the 1st rising edge of SCLK after SEN. SDI high initiates the READ cycle (RD)
- c. Host places the six address bits on the next six falling edges of SCLK, MSB first.
- d. Slave registers the address bits on the next six rising edges of SCLK (2-7).
- e. Slave switches from Lock Detect and places the requested 24 data bits on SD_LDO on the next 24 rising edges of SCK (8-31), MSB first .
- f. Host registers the data bits on the next 24 falling edges of SCK (8-31).
- g. Slave restores Lock Detect on the 32nd rising edge of SCK.
- h. SEN is de-asserted on the 32nd falling edge of SCLK.
- i. The 32nd falling edge of SCLK completes the READ cycle.

Table 10. SPI HMC Mode - Read Timing Characteristics

Parameter	Conditions	Min.	Typ.	Max.	Units
t ₁	SEN to SCLK setup time	8			ns
t ₂	SDI setup to SCLK time	3			ns
t ₃	SCLK to SDI hold time	3			ns
t ₄	SEN low duration	20			ns
t ₅	SCLK to SDO delay		8.2ns+0.2ns/pF		ns

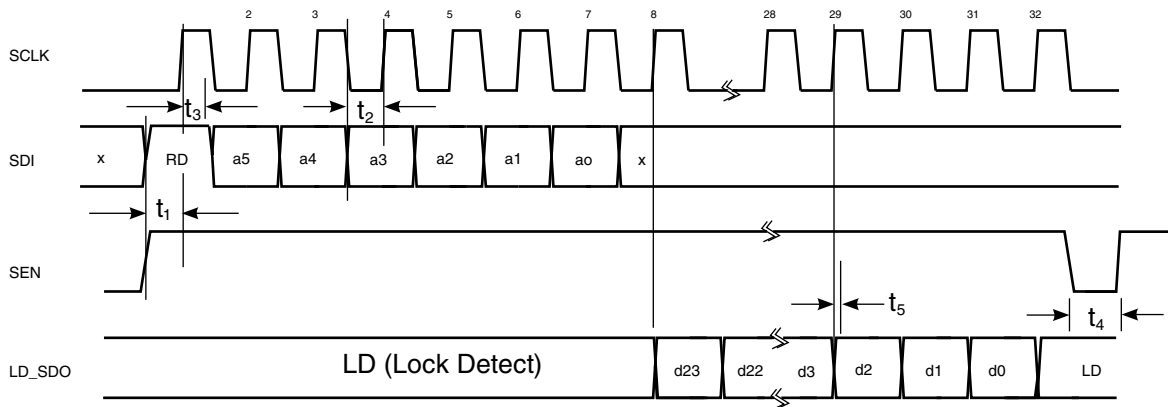

Figure 37. HMC Mode Serial Port Timing Diagram - READ

Open Mode - Serial Port WRITE Operation

AVDD = DVDD = 3.3V +/-10%, AGND = DGND = 0V

Table 11. SPI Open Mode - Write Timing Characteristics

Parameter	Conditions	Min.	Typ.	Max.	Units
t ₁	SDI setup time	3			ns
t ₂	SDI hold time	1			ns
t ₃	SEN low duration	10			ns
t ₄	SEN high duration	10			ns
t ₅	SCLK 32 Rising Edge to SEN Rising Edge Serial port Clock Speed	DC	50		MHz

 A typical WRITE cycle is shown in [Figure 38](#).

- The Master (host) places 24 bit data, d23:d0, MSB first, on SDI on the first 24 falling edges of SCLK.
- the slave (PLL) shifts in data on SDI on the first 24 rising edges of SCLK
- Master places 5 bit register address to be written to, r4:r0, MSB first, on the next 5 falling edges of SCLK (25-29)
- Slave shifts the register bits on the next 5 rising edges of SCLK (25-29).
- Master places 3 bit chip address, a2:a0, MSB first, on the next 3 falling edges of SCLK (30-32). Hittite reserves chip address a2:a0 = 000 for all RF PLL-VCOs.
- Slave shifts the chip address bits on the next 3 rising edges of SCLK (30-32).
- Master asserts SEN after the 32nd rising edge of SCLK.
- Slave registers the SDI data on the rising edge of SEN.
- Master clears SEN to complete the WRITE cycle.

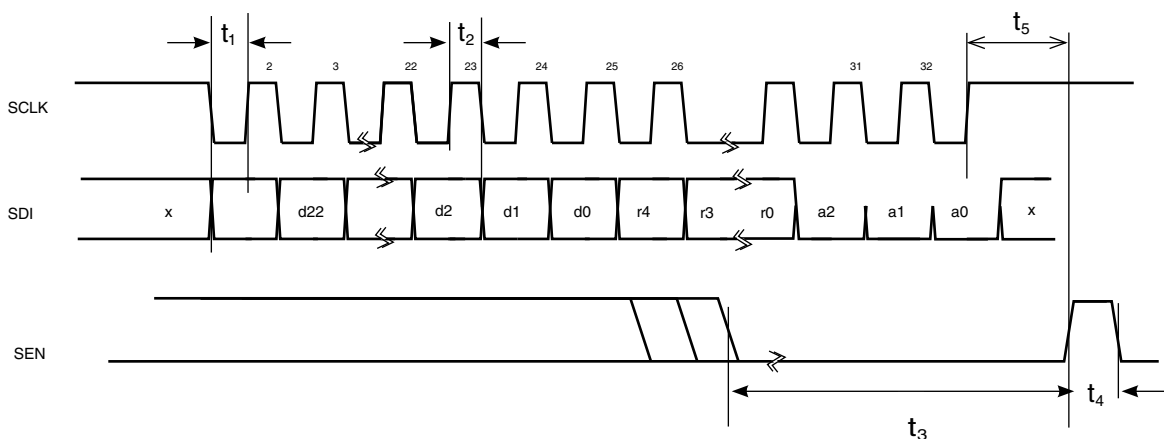

Figure 38. Open Mode - Serial Port Timing Diagram - WRITE



Open Mode - Serial Port READ Operation

A typical READ cycle is shown in [Figure 39](#).

In general, in Open Mode the LD_SDO line is always active during the WRITE cycle. During any Open Mode SPI cycle LD_SDO will contain the data from the current address written in "Reg 00h"[4:0]. If "Reg 00h"[4:0] is not changed then the same data will always be present on LD_SDO when an Open Mode cycle is in progress. If it is desired to READ from a specific address, it is necessary in the first SPI cycle to write the desired address to "Reg 00h"[4:0], then in the next SPI cycle the desired data will be available on LD_SDO.

An example of the Open Mode two cycle procedure to read from any random address is as follows:

- a. The Master (host), on the first 24 falling edges of SCLK places 24 bit data, d23:d0, MSB first, on SDI as shown in [Figure 39](#). d23:d5 should be set to zero. d4:d0 = address of the register to be READ on the next cycle.
- b. the slave (PLL) shifts in data on SDI on the first 24 rising edges of SCLK
- c. Master places 5 bit register address, r4:r0, (the address the READ ADDRESS register), MSB first, on the next 5 falling edges of SCLK (23-29). r4:r0=00000.
- d. Slave shifts the register bits on the next 5 rising edges of SCLK (23-29).
- e. Master places 3 bit chip address, a2:a0, MSB first, on the next 3 falling edges of SCLK (30-32). Chip address is always 000 for RF PLL-VCOs.
- f. Slave shifts the chip address bits on the next 3 rising edges of SCLK (30-32).
- g. Master asserts SEN after the 32nd rising edge of SCLK.
- h. Slave registers the SDI data on the rising edge of SEN.
- i. Master clears SEN to complete the address transfer of the two part READ cycle.
- j. If we do not wish to write data to the chip at the same time as we do the second cycle, then it is recommended to simply rewrite the same contents on SDI to Register zero on the READ back part of the cycle.
- k. Master places the same SDI data as the previous cycle on the next 32 falling edges of SCLK.
- l. Slave (PLL) shifts the SDI data on the next 32 rising edges of SCLK.
- m. Slave places the desired data (i.e. data from address in "Reg 00h"[4:0]) on LD_SDO on the next 32 rising edges of SCLK. Lock Detect is disabled.
- n. Master asserts SEN after the 32nd rising edge of SCLK to complete the cycle and revert back to Lock Detect on LD_SDO.

Note that if the chip address bits are unrecognized (a2:a0), the slave will tri-state the LD_SDO output to prevent a possible contention issue.

Table 12. SPI Open Mode - Read Timing Characteristics

Parameter	Conditions	Min.	Typ.	Max.	Units
t ₁	SDI setup time	3			ns
t ₂	SDI hold time	3			ns
t ₃	SEN low duration	10			ns
t ₄	SEN high duration	10			ns
t ₅	SCLK Rising Edge to SDO time		8.2+0.2ns/pF		ns

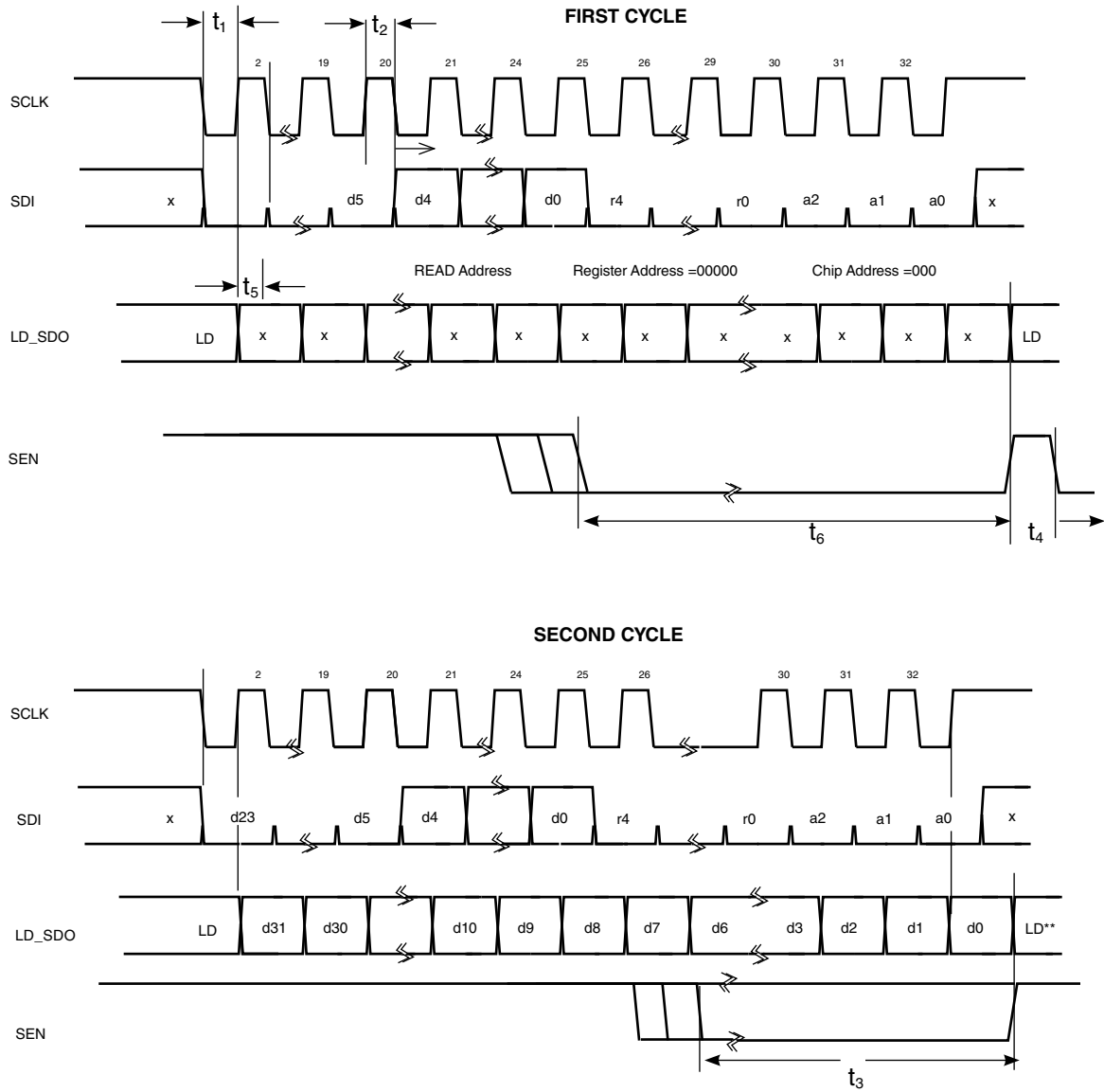

**Note: Read-back on LD_SDO can function without SEN, however SEN rising edge is required to return the LD_SDO to the LD state

Figure 39. Open Mode - Serial Port Timing Diagram - READ Operation 2-Cycles



AUX SERIAL PORT

The PLL also features a general purpose 16 bit Aux Serial Port (AuxSPI). The auxiliary serial port may be used to control other chips if available, via the Open mode protocol.

The AuxSPI outputs the contents of “Reg 05h” upon receipt of a frequency change command. The AuxSPIdata is output at the AuxSPI clock rate which is fpd (“Reg 05h”[6]). A single AuxSPI transfer requires 16 AuxSPI cycles plus 4 overhead cycles.

REGISTER MAP

Table 13. Reg 00h ID Register (Read Only)

BIT	TYPE	NAME	W	DEFLT	DESCRIPTION
[23:0]	RO	chip_ID	24	A7975h	PLL Subsystem ID, 94075

Table 13. Reg 00h Open Mode and HMC Mode Reset Strobe Register (Write Only)

(Continued)

BIT	TYPE	NAME	W	DEFLT	DESCRIPTION
[5]	WO	rst_swrst	1	-	Strobe (WRITE ONLY) generates soft reset. Resets all digital and registers to default states

Table 13. Reg 00h Open Mode Read Address Register (Write Only) (Continued)

BIT	TYPE	NAME	W	DEFLT	DESCRIPTION
[4:0]	WO	Open Mode Read Address	5	-	Specifies address to read when in Open Mode 2 cycle read

Table 14. Reg 01h POWERDN Register

BIT	TYPE	NAME	W	DEFLT	DESCRIPTION
[0]	R/W	chipen_pin_select	1	0	1 = chip enable via CEN pin, Reg01[0]=1 and CEN pin low puts PLL in Power Down Mode, see Power Down Mode description 0 = PLL Subsystem chip enable via SPI (rst_chipen_from_spi) Reg01[1]
[1]	R/W	chipen_from_spi	1	1	Controls PLL Subsystem Chip Enable (Power Down) if rst_chipen_pin_select Reg01[0]=0 and Reg01[1]=1 = chip enabled, CEN don't care Reg01[0]=0 and Reg01[1]=0 = chip disabled, CEN don't care see Power Down Mode description and csp_enable
[2]	R/W	Keep_Bias On	1	0	keeps internal bias generators on, ignores Chip enable control
[3]	R/W	Keep_PFD_on	1	0	keeps PFD circuit on, ignores Chip enable control
[4]	R/W	Keep_CP_On	1	0	keeps Charge Pump on, ignores Chip enable control
[5]	R/W	Keep_Ref_buf ON	1	0	keeps Reference buffer block on, ignores Chip enable control
[6]	R/W	Keep_VCO_on	1	0	keeps VCO divider buffer on, ignores Chip enable control
[7]	R/W	Keep_GPO_driver ON	1	0	keeps GPO output Driver ON, ignores Chip enable control
[8]	R/W	reserved	1	0	reserved

Table 15. Reg 02h REFDIV Register

BIT	TYPE	NAME	W	DEFLT	DESCRIPTION
[13:0]	R/W	rdiv	14	1	Reference Divider 'R' Value (EQ 8) Divider use also requires refBufEn Reg08[3]=1 min 0d max 16383d

Table 16. Reg 03h Frequency Register - Integer Part

BIT	TYPE	NAME	W	DEFLT	DESCRIPTION
[18:0]	R/W	intg	19	200d C8h	VCO Divider Integer part, used in all modes, see (EQ 10) Fractional Mode min 20d max $2^{19}-4 = 7FFFC_{16} = 524,284_{10}$ Integer Mode min 16d max $2^{19}-1 = 7FFFF_{16} = 524,287_{10}$

Table 17. Reg 04h Frequency Register - Fractional Part

BIT	TYPE	NAME	W	DEFLT	DESCRIPTION
[23:0]	R/W	frac	24	0	VCO Divider Fractional part (24 bit unsigned) see Fractional Frequency Tuning Fractional Division Value = $\text{Reg4}[23:0]/2^{24}$ Used in Fractional Mode only min 0d max $2^{24}-1 = FFFFFFF_{16} = 16,777,215_{10}$

Table 18. Reg 05h Aux SPI Register

BIT	TYPE	NAME	W	DEFLT	DESCRIPTION
[15:0]	R/W	Aux Data	16	0	Data to be output on ASD pin

Table 19. Reg 06h SD CFG Register

BIT	TYPE	NAME	W	DEFLT	DESCRIPTION
[1:0]	R/W	seed select	2	2	Selects the Seed in Fractional Mode 00: 0 seed 01: lsb seed 02: B29D08h seed 03: 50F1CDh seed Note; Writes to this register are stored in the PLL and are only loaded into the modulator when a frequency change is executed and if autoseed Reg06h[13] =1
[3:2]	R/W	Modulator order	2	2	Select the Delta Sigma Modulator Type 0: Reserved 1: Reserved 2: Mode B Offers better out of band spectral performance. Mode B Required for Exact Frequency Mode. 3: Mode A Offers better in band spectral performance
[6:4]	R/W	Reserved	3	7	
[7]	R/W	frac_bypass	1	0	0: Use Modulator, Required for Fractional Mode, 1: Bypass Modulator, Required for Integer Mode Note: In bypass fractional modulator output is ignored, but fractional modulator continues to be clocked if frac_rstb =1, Can be used to test the isolation of the digital fractional modulator from the VCO output in integer mode
[8]	R/W	autoseed	1	1	1: loads the modulator seed (start phase) whenever the frac register is written 0: when frac register write changes frequency, modulator starts with previous contents
[9]	R/W	clkqr_refdiv_sel	1	1	selects the modulator core clock source- for Test Only 1: VCO divider clock 0: Ref divider clock Ignored if bits [10] or [21] are set
[10]	R/W	Modulator Core Clk Select	1	0	0 - Modulator auxclk, 1- Modulator VCO Clock delay
[11]	R/W	frac_rstb	1	1	0: disable Modulator, use for Integer Mode or Integer Mode with CSP 1: Enable Modulator Core, required for Fractional Mode, or Integer isolation testing
[12]	R/W	Reserved	1	0	
[13]	R/W	Reserved	1	0	
[15:14]	R/W	Reserved	2	0	Reserved
[17:16]	R/W	Reserved	2	0	Program to 3 decimal "11" binary
[18]	R/W	BIST Enable	1	0	Enable Built in Self Test
[20:19]	R/W	RDIV BIST Cycles	2	0	0:1023 1:2047 2:3071 3:4095
[21]	R/W	Reserved	1	0	Reserved
[22]	R/W	Reserved	1	0	Reserved

Table 20. Reg 07h Lock Detect Register

BIT	TYPE	NAME	W	DEFLT	DESCRIPTION
[2:0]	R/W	lkd_wincnt_max	3	5	Lock Detect window sets the number of consecutive counts of divided VCO that must land inside the Lock Detect Window to declare LOCK 0: 5 1: 32 2: 96 3: 256 4: 512 5: 2048 6: 8192 7: 65535
[3]	R/W	Enable Internal Lock Detect	1	1	Enable Internal Lock Detect
[5:4]	R/W	Reserved	2	0	Reserved
[6]	R/W	Lock Detect Window type	1	0	Lock Detection Window Timer Selection 1: Digital programmable timer 0: Analog one shot, nominal +/-10nsec window
[9:7]	R/W	LD Digital Window duration	3	0	Lock Detection - Digital Window Duration 0: 1/2 cycle 1: 1 cycle 2: 2 cycles 3: 4 cycles 4: 8 cycles 5: 16 cycles 6: 32 cycles 7: 64 cycles
[11:10]	R/W	LD Digital Timer Freq Control	2	0	Lock Detect Digital Timer Frequency Control "00" fastest "11" slowest
[12]	R/W	LD Timer Test Mode	1	0	1: Force Timer ON Continuously - For Test Only 0: Normal Timer operation - one shot
[13]	R/W	Auto Relock - One Try	1	0	1: Attempts to relock if Lock Detect fails for any reason Only tries once.

Table 21. Reg 08h Analog EN Register

BIT	TYPE	NAME	W	DEFLT	DESCRIPTION
0	R/W	bias_en	1	1	Enables main chip bias reference
1	R/W	cp_en	1	1	Charge pump enable
2	R/W	pd_en	1	1	PD enable
3	R/W	refbuf_en		1	Reference path buffer enable
4	R/W	vcobuf_en	1	1	VCO path RF buffer enable
5	R/W	GPO/LDO/SDO_pad_en	1	1	0 - Pin LD_SDO disabled
6	R/W	spare	1	1	spare
7	R/W	VCO_Div_Clk_to_dig_en	1	1	VCO Divider Clock to Digital Enable
8	R/W	Reserved	1	0	Reserved
9	R/W	Prescaler Clock enable	1	1	Prescaler clock enable
[10]	R/W	VCO Buffer and Prescaler Bias Enable	1	1	VCO Buffer and Prescaler Bias Enable
[11]	R/W	Charge Pump Internal Opamp enable	1	1	Charge Pump Internal Opamp enable
[14:12]	R/W	RF Buffer En/Bias	3	3	0: Disabled, 1: Low Bias,...7: High Bias
[17:15]	R/W	Div Resync En/Bias	3	3	0: Disabled, 1: Low Bias,...7: High Bias
[18]	R/W	Reserved	1	0	Reserved Program 0
[19]	R/W	8GHz Divide by 2 En	1	0	8GHz Divide by 2 Enable
[20]	R/W	Reserved	1	0	Reserved Program 0
[21]	R/W	Hi Frequency Reference	1	0	Program 1 for XTAL > 200 MHz
[22]	R/W	Reserved	1	1	Reserved
[23]	R/W	Reserved	1	1	Reserved

Table 22. Reg 09h Charge Pump Register

BIT	TYPE	NAME	W	DEFLT	DESCRIPTION
[6:0]	R/W	CP DN Gain	7	10d	Charge Pump DN Gain Control 20uA/step Affects fractional phase noise and lock detect settings 0d = 0uA 1d = 20uA 2d = 40uA ... 127d = 2.54mA
[13:7]	R/W	CP UP Gain	7	10d	Charge Pump UP Gain Control 20uA/step Affects fractional phase noise and lock detect settings 0d = 0uA 1d = 20uA 2d = 40uA ... 127d = 2.54mA
[20:14]	R/W	Offset Current	7	0	Charge Pump Offset Control 5uA/step Affects fractional phase noise and spurs and lock detect settings 0d = 0uA 1d = 5uA 2d = 110uA ... 127d = 635uA
[21]	R/W	Offset Current UP	1	0	1 - Sets Direction of Reg[20:14] Up, 0- UP Offset Off
[22]	R/W	Offset Current DN	1	1	1 - Sets Direction of Reg[20:14] Down, 0- DN Offset Off
[23]	R/W	HiK charge pump Mode	1	0	Hi Kcp Charge Pump - Very Low Noise, Narrow Compliance range, requires Opamp

Table 23. Reg 0Ah AuxSPI Trigger Register

BIT	TYPE	NAME	W	DEFLT	DESCRIPTION
[11:0]	R/W	Reserved	12	0	Reserved
[12]	R/W	No AuxSPI Trigger	1	0	No AuxSPI trigger on Reg5 Write
[15:13]	R/W	reserved	3	0	Reserved
[16]	R/W	Force RDivider Bypass	1	0	Force the R Divider Bypass, ignore Reg03

Table 24. Reg 0Bh PD Register

BIT	TYPE	NAME	W	DEFLT	DESCRIPTION
[2:0]	R/W	pd_del_sel	3	1	Sets PD reset path delay
[3]	R/W	Short PD Inputs	1	0	Shorts the inputs to the Phase Detector - Test Only
[4]	R/W	pd_Invert	1	0	Inverts the PD polarity 0 - Use with a positive tuning slope VCO and passive loop filter (default). 1 - Use with a negative slope VCO or with an inverting active loop filter with a positive slope VCO.
[5]	R/W	pd_up_en	1	1	Enables the PD UP output, see also Reg0B[9]
[6]	R/W	pd_dn_en	1	1	enables the PD DN output, see also Reg0B[9]
[8:7]	R/W	CSP Mode	2	0	Cycle Slip Prevention Mode 0: CSP Disabled 1: CP Gain increased if Phase Error > 2 nsec 2: CP Gain increased if Phase Error > 4 nsec 3: CP Gain increased if Phase Error > 6 nsec
[9]	R/W	Force CP UP	1	0	Forces CP UP output on - Use for Test only
[10]	R/W	Force CP DN	1	0	Forces CP DN output on - Use for Test only
[11]	R/W	Force CP Mld Rail	1	0	Force CP Mld Rail - Use for Test only
[14:12]	R/W	PS Bias	3	0	Prescaler Bias 0: Nominal 1: +20% RF Buffer 2: +25% Rsync 3: +50%
[16:15]	R/W	CP Internal OpAmp Bias	2	3	CP Internal OpAmp Bias
[18:17]	R/W	MCounter Clock Gating	2	3	MCounter Clock Gating 0: MCounter Off for N<32 1: N<128 2: N< 1023 3: All Clocks ON
[19]	R/W	Reserved	1	1	
[21:20]	R/W	Divider Pulse Width	2	0	0: shortest, ... 3: Longest
[23:22]	R/W	Reserved	2	0	

Table 25. Reg 0Ch Exact Frequency Register

BIT	TYPE	NAME	W	DEFLT	DESCRIPTION
[13:0]	R/W	Number of Channels per Fpd	14	0	Comparison Frequency divided by the channel spacing. Must be an integer. Frequencies at multiples of the channel spacing will have zero frequency error. Only works in modulator Mode B. Must be 0 otherwise 0: Disabled 1: Disabled 2 to 16383d (3FFFh) allowed

Table 26. Reg 0Fh GPO Register

BIT	TYPE	NAME	W	DEFLT	DESCRIPTION
[4:0]	R/W	gpo_select	5	1	Signal selected here is output to SDO pin when enabled 0: Data from Reg0F[5] 1: Lock Detect Output 2: Lock Detect Trigger 3: Lock Detect Window Output 4: Ring Osc Test 5: Pullup Hard from CSP 6: PullDN hard from CSP 7: Reserved 8: Reference Buffer Output 9: Ref Divider Output 10: VCO divider Output 11: Modulator Clock from VCO divider 12: Auxiliary Clock 13: Aux SPI Clock 14: Aux SPI Enable 15: Aux SPI Data Out 16: PD DN 17: PD UP 18: SD3 Clock Delay 19: SD3 Core Clock 20: AutoStrobe Integer Write 21: AutoStrobe Frac Write 22: AutoStrobe Aux SPI 23: SPI Latch Enable 24: VCO Divider Sync Reset 25: Seed Load Strobe 26.-29 Not Used 30: SPI Output Buffer En 31: Soft RSTB
[5]	R/W	GPO Test Data	1	0	1 - GPO Test Data when GPO_Select = 0
[6]	R/W	Prevent Automux SDO	1	0	1- inhibits Automux of the SPI SDO line with Lock Detect
[7]	R/W	Prevent Driver Disable	1	0	1- Prevents SPI from disabling SDO. Should be 1 if using HMC SPI mode.
[8]	R/W	Disable PFET	1	0	Disable PFET
[9]	R/W	Disable NFET	1	0	Disable NFET

Table 27. Reg 10h Reserve Register (Read Only)

BIT	TYPE	NAME	W	DEFLT	DESCRIPTION
[8:0]	RO	Reserved	9	0	Reserved

Table 28. Reg 11h Reserve Register (Read Only)

BIT	TYPE	NAME	W	DEFLT	DESCRIPTION
[18:0]	RO	Reserved	19	0	Reserved

Table 29. Reg 12h GPO2 Register (Read Only)

BIT	TYPE	NAME	W	DEFLT	DESCRIPTION
[0]	RO	GPO	1	0	GPO
[1]	RO	Lock Detect	1	0	Lock Detect

Table 30. Reg 13h BIST Register

BIT	TYPE	NAME	W	DEFLT	DESCRIPTION
[15:0]	RO	BIST Signature	16	0	Digital Built-In Self Test Signature
[16]	RO	BIST Busy	1	0	BIST Busy