

● Inner circuit

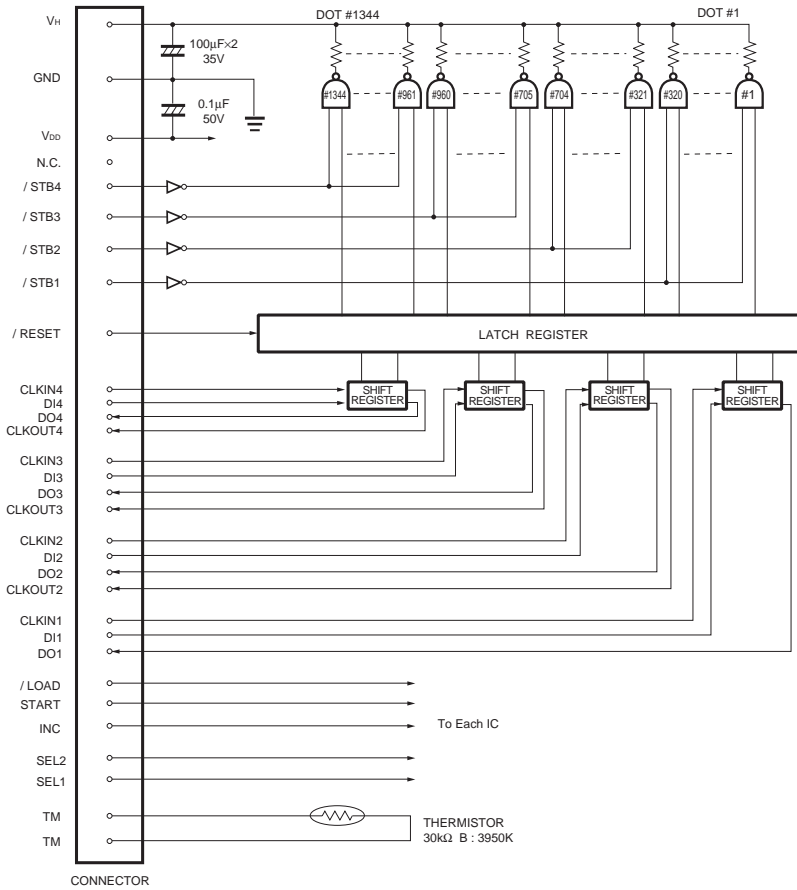

DI No.	DOT No.	/ STB No.	DOT No.	CLK No.	DOT No.
DI4	1344 to 961	/ STB4	1344 to 961	CLKIN4	1344 to 961
DI3	960 to 705	/ STB3	960 to 705	CLKIN3	960 to 705
DI2	704 to 321	/ STB2	704 to 321	CLKIN2	704 to 321
DI1	320 to 1	/ STB1	320 to 1	CLKIN1	320 to 1

Fig.1

●Pin assignments

CONNECTOR A			
No.	Circuit	No.	Circuit
1	V _{DD}	18	/ LOAD
2	V _{DD}	19	/ RESET
3	NC	20	START
4	NC	21	TM
5	SEL2	22	TM
6	SEL1	23	DI2
7	CLKIN4 (CP)	24	DO2
8	CLKOUT4	25	DI1
9	CLKIN3	26	DO1
10	CLKOUT3	27	/ STB2
11	DI4	28	/ STB1
12	DO4	29	CLKIN2
13	DI3	30	CLKOUT2
14	DO3	31	CLKIN1
15	/ STB4	32	NC
16	/ STB3	33	NC
17	INC	34	NC

CONNECTOR B	
No.	Circuit
1	V _H (COM)
2	V _H (COM)
3	V _H (COM)
4	V _H (COM)
5	V _H (COM)
6	GND
7	GND
8	GND
9	GND
10	GND

●Characteristics

Parameter	Symbol	Typical	Unit
Effective printing width	—	168	mm
Dot pitch	—	0.125	mm
Total dot number	—	1344	dots
Average resistance value	Rave	650	Ω
Applied voltage	V _H	24	V
Applied power	P _o	0.75	W/dot
Print cycle	SLT	0.49	ms
Maximum number of dots energized simultaneously	—	1344	dots
Maximum clock frequency	—	8	MHz
Maximum roller diameter	—	φ20.0	mm
Running life / pulse life	—	150/(1×10 ⁸)	km/pulses
Operating temperature	—	5 to 45	°C

●Data sheets

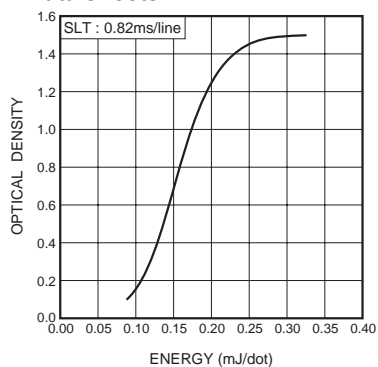

Fig.2 Representative density curve

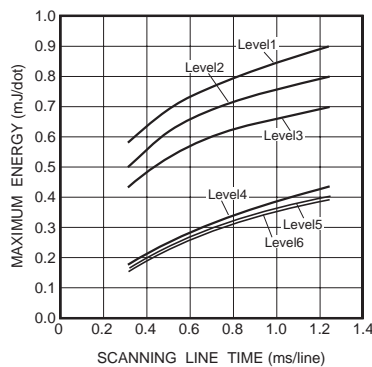

Fig.3 Maximum energy curve

Notes

No copying or reproduction of this document, in part or in whole, is permitted without the consent of ROHM Co.,Ltd.

The content specified herein is subject to change for improvement without notice.

The content specified herein is for the purpose of introducing ROHM's products (hereinafter "Products"). If you wish to use any such Product, please be sure to refer to the specifications, which can be obtained from ROHM upon request.

Examples of application circuits, circuit constants and any other information contained herein illustrate the standard usage and operations of the Products. The peripheral conditions must be taken into account when designing circuits for mass production.

Great care was taken in ensuring the accuracy of the information specified in this document. However, should you incur any damage arising from any inaccuracy or misprint of such information, ROHM shall bear no responsibility for such damage.

The technical information specified herein is intended only to show the typical functions of and examples of application circuits for the Products. ROHM does not grant you, explicitly or implicitly, any license to use or exercise intellectual property or other rights held by ROHM and other parties. ROHM shall bear no responsibility whatsoever for any dispute arising from the use of such technical information.

The Products specified in this document are intended to be used with general-use electronic equipment or devices (such as audio visual equipment, office-automation equipment, communication devices, electronic appliances and amusement devices).

The Products specified in this document are not designed to be radiation tolerant.

While ROHM always makes efforts to enhance the quality and reliability of its Products, a Product may fail or malfunction for a variety of reasons.

Please be sure to implement in your equipment using the Products safety measures to guard against the possibility of physical injury, fire or any other damage caused in the event of the failure of any Product, such as derating, redundancy, fire control and fail-safe designs. ROHM shall bear no responsibility whatsoever for your use of any Product outside of the prescribed scope or not in accordance with the instruction manual.

The Products are not designed or manufactured to be used with any equipment, device or system which requires an extremely high level of reliability the failure or malfunction of which may result in a direct threat to human life or create a risk of human injury (such as a medical instrument, transportation equipment, aerospace machinery, nuclear-reactor controller, fuel-controller or other safety device). ROHM shall bear no responsibility in any way for use of any of the Products for the above special purposes. If a Product is intended to be used for any such special purpose, please contact a ROHM sales representative before purchasing.

If you intend to export or ship overseas any Product or technology specified herein that may be controlled under the Foreign Exchange and the Foreign Trade Law, you will be required to obtain a license or permit under the Law.



Thank you for your accessing to ROHM product informations.
More detail product informations and catalogs are available, please contact us.

ROHM Customer Support System

<http://www.rohm.com/contact/>