

Compact medium speed thick film thermal printhead (8dots / mm)

KD2002-CG10A

KD2002-CG10A is suitable for devices, such as high-speed POS and label printer applications, that require thermal printheads capable of higher printing rates. Improved power circuit design means that with heavier current it is possible to print at speeds as high as 150 mm/s. The GK Series is thus ideal for label printers that need high printing rates.

●Applications

POS terminals, Label printers, CAT terminals, Multi-purpose small-sized printers

●Features

- 1) Using a special compact partial glaze and new heating element structure, achieves high-speed printing at 150 mm/s.
- 2) The use of the newly developed highly-durable conductive protective film has improved countermeasures against static electricity.
- 3) The VH and GND sections of the power circuitry have been strengthened so that heavier current can be applied.
- 4) Ultra small connectors, designed to conform with FFCs, and miniature driver chips have been used. Although the resulting printheads are surprisingly compact and lightweight, they can be used with large platens of up to 20 mm in diameter.
- 5) One rank resistance value of $800\Omega \pm 3\%$ eliminates the inconvenience of rank selection.
- 6) The required driving voltage of 3.15 to 5.25V allows wide range of power supply voltage setting. This also allows multiple choice of electronic components for printers.
- 7) 2-inch, 3-inch and 4-inch series are available.

●External dimensions (Unit : mm)

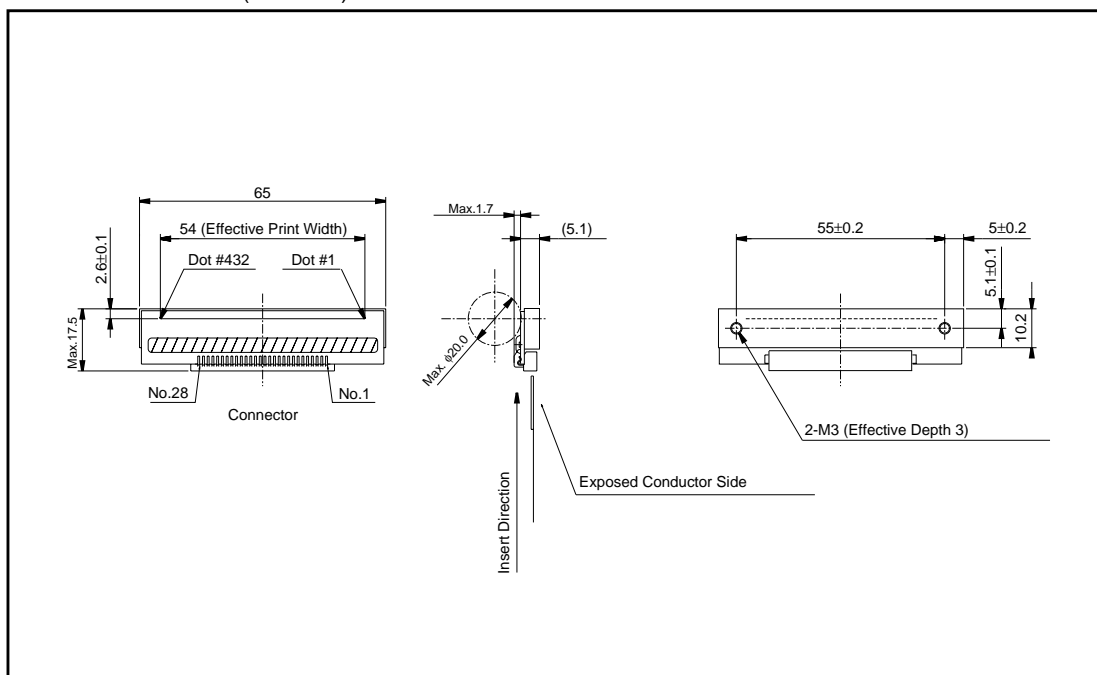

Printheads

●Equivalent circuit

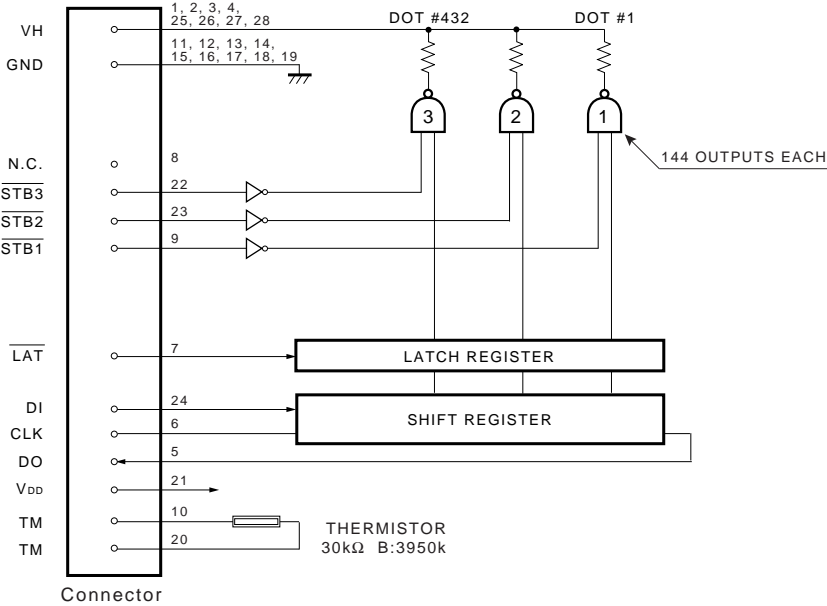

Fig.1

●Pin assignments

No.	Circuit
1	VH
2	VH
3	VH
4	VH
5	DO
6	CLK
7	LAT
8	N.C.
9	STB1
10	TM
11	GND
12	GND
13	GND
14	GND

No.	Circuit
15	GND
16	GND
17	GND
18	GND
19	GND
20	TM
21	VDD
22	STB3
23	STB2
24	DI
25	VH
26	VH
27	VH
28	VH

Printheads

●Timing chart

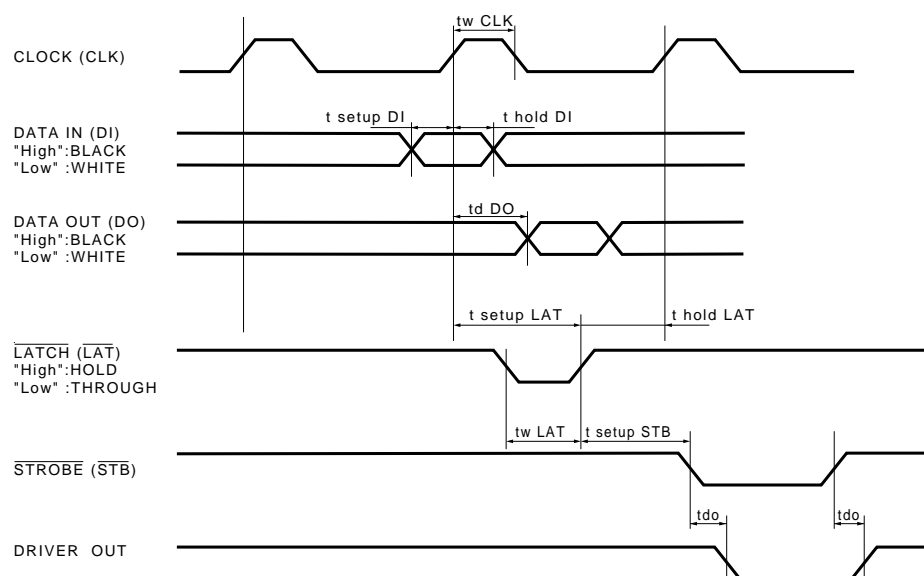

Fig.2

●Characteristics

Parameter	Symbol	Typical	Unit
Effective printing width	—	54	mm
Dot pitch	—	0.125	mm
Total dot number	—	432	dots
Average resistance value	Rave	800	Ω
Applied voltage	VH	24.0	V
Applied power	PO	0.59	W/dot
Print cycle	SLT	1.0	ms
Pulse width	TON	0.43	ms
Maximum number of dots energized simultaneously	—	432	dots
Maximum clock frequency	—	16	MHz
Maximum roller diameter	—	$\phi 20.0$	mm
Running life / pulse life	—	$50/5 \times 10^7$	km/pulses
Operating temperature	—	5 to 45	$^{\circ}\text{C}$

Printheads

●Electrical characteristic curves

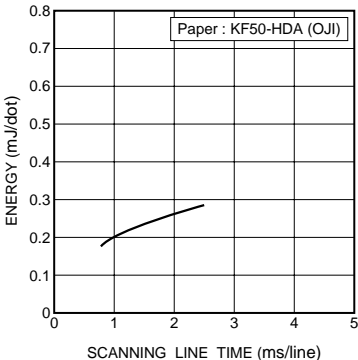

Fig.3 Adaptive speed chart

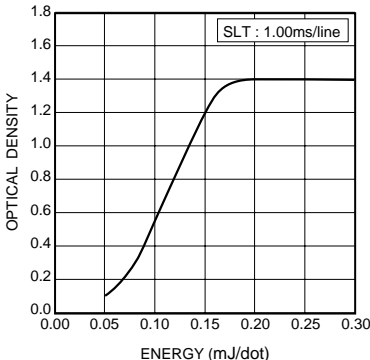

Fig.4 Representative density curve

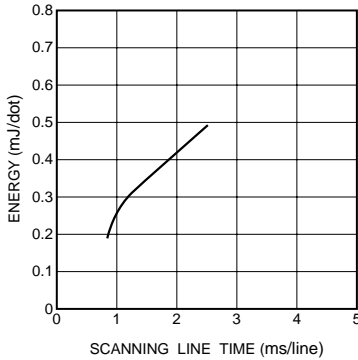

Fig.5 Maximum energy curve

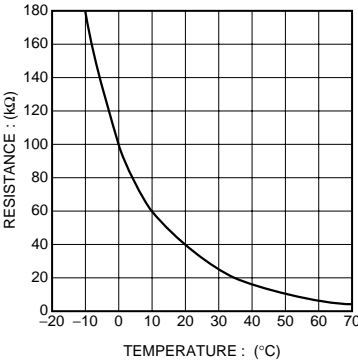

Fig.6 Thermistor curve

Notes

- No technical content pages of this document may be reproduced in any form or transmitted by any means without prior permission of ROHM CO.,LTD.
- The contents described herein are subject to change without notice. The specifications for the product described in this document are for reference only. Upon actual use, therefore, please request that specifications to be separately delivered.
- Application circuit diagrams and circuit constants contained herein are shown as examples of standard use and operation. Please pay careful attention to the peripheral conditions when designing circuits and deciding upon circuit constants in the set.
- Any data, including, but not limited to application circuit diagrams information, described herein are intended only as illustrations of such devices and not as the specifications for such devices. ROHM CO.,LTD. disclaims any warranty that any use of such devices shall be free from infringement of any third party's intellectual property rights or other proprietary rights, and further, assumes no liability of whatsoever nature in the event of any such infringement, or arising from or connected with or related to the use of such devices.
- Upon the sale of any such devices, other than for buyer's right to use such devices itself, resell or otherwise dispose of the same, no express or implied right or license to practice or commercially exploit any intellectual property rights or other proprietary rights owned or controlled by
- ROHM CO., LTD. is granted to any such buyer.
- Products listed in this document are no antiradiation design.

The products listed in this document are designed to be used with ordinary electronic equipment or devices (such as audio visual equipment, office-automation equipment, communications devices, electrical appliances and electronic toys).

Should you intend to use these products with equipment or devices which require an extremely high level of reliability and the malfunction of which would directly endanger human life (such as medical instruments, transportation equipment, aerospace machinery, nuclear-reactor controllers, fuel controllers and other safety devices), please be sure to consult with our sales representative in advance.

About Export Control Order in Japan

Products described herein are the objects of controlled goods in Annex 1 (Item 16) of Export Trade Control Order in Japan.

In case of export from Japan, please confirm if it applies to "objective" criteria or an "informed" (by MITI clause) on the basis of "catch all controls for Non-Proliferation of Weapons of Mass Destruction.