

Conductive polymer chip capacitors (Bottom surface electrode type : Large capacitance)

TCTO Series A Case

●Features (A)

- 1) Conductive polymer used for the cathode material.
- 2) Ultra low ESR
- 3) Small package, but big capacitance
- 4) Screening by thermal shock

●Dimensions (Unit : mm)

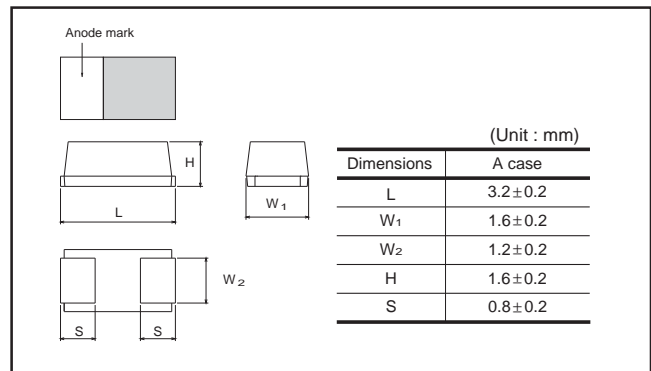

●Part No. Explanation

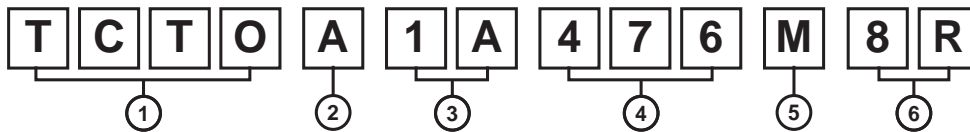

① Series name
TCTO

② Case style
A

③ Rated voltage

| | | | | | | | |
|-------------------|-----|----|-----|----|----|----|----|
| Rated voltage (V) | 2.5 | 4 | 6.3 | 10 | 16 | 20 | 25 |
| CODE | 0E | 0G | 0J | 1A | 1C | 1D | 1E |

④ Nominal capacitance
Nominal capacitance in pF in 3 digits:
2 significant figures followed by the figure
representing the number of 0's.

⑤ Capacitance tolerance
M : ±20%

⑥ Taping
8 : Tape width
R : Positive electrode on the side opposite to sprocket hole

* This specification has possibility of charge, due to underdevelopment product.
Please ask for latest specification to our sales.

● **Rated table**

(ESR : mΩ)

| (μF) | Rated voltage (V.DC) | | | | | | |
|-----------|----------------------|------------|-----------|---------|------|------|------|
| | 2.5 | 4 | 6.3 | 10 | 16 | 20 | 25 |
| 4.7 (475) | | | | | | | *100 |
| 6.8 (685) | | | | | | *100 | |
| 10 (106) | | | | | *100 | | |
| 15 (156) | | | | | | | |
| 22 (226) | | | | | | | |
| 33 (336) | | | | 70/100 | | | |
| 47 (476) | | | | *70/100 | | | |
| 68 (686) | | | 35/70/100 | | | | |
| 100 (107) | | 35/70/100 | 35/70/100 | | | | |
| 150 (157) | | *35/70/100 | | | | | |
| 220 (227) | 35/70/100 | | | | | | |
| 330 (337) | *35/70/100 | | | | | | |

*Under development

● **Marking**

The indications listed below should be given on the surface of a capacitor.

- (1) Polarity : The polarity should be shown by □ bar. (on the anode side)
- (2) Rated DC voltage : A voltage code is shown as below table.
- (3) Capacitance value : A capacitance code is shown as below table.

| Voltage Code | Rated DC Voltage (V) |
|--------------|----------------------|
| e | 2.5 |
| g | 4 |
| j | 6.3 |
| A | 10 |
| C | 16 |
| D | 20 |
| E | 25 |

| Capacitance Code | Capacitance Value (μF) |
|------------------|------------------------|
| S | 4.7 |
| W | 6.8 |
| a | 10 |
| e | 15 |
| j | 22 |
| n | 33 |
| s | 47 |
| w | 68 |
| ā | 100 |
| ē | 150 |
| ī | 220 |
| ñ | 330 |

Visual typical example (1) voltage code (2) capacitance code

[A case] note 1)

A s
(1) (2)

manufacture code

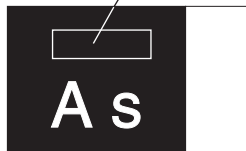

note 2) voltage code and capacitance code are variable with parts number

● Characteristics

| Item | | Performance | Test conditions (based on JIS C 5101-1 and JIS C 5101-3) | | | | | | | | | | | | | | | |
|--|----------------------------------|--|--|---------------|-------|------|---|---------|----------|---|------------|---------------|---|---------|----------|---|------------|---------------|
| Operating Temperature | | -55°C to +105°C | Voltage reduction when temperature exceeds +85°C | | | | | | | | | | | | | | | |
| Maximum operating temperature with no voltage derating | | +85°C | | | | | | | | | | | | | | | | |
| Rated voltage (V.DC) | | 2.5 4 6.3 10 16 20 25 | at 85°C | | | | | | | | | | | | | | | |
| Category voltage (V.DC) | | 2 3.2 5 8 12.8 16 20 | at 105°C | | | | | | | | | | | | | | | |
| Surge voltage (V.DC) | | 3.2 5 8 13 20 23 29 | at 85°C | | | | | | | | | | | | | | | |
| DC leakage current | | Shall be satisfied the value on " Standard list " | As per 4.9 JIS C 5101-1 As per 4.5.1 JIS C 5101-3 Voltage : Rated voltage for 5min | | | | | | | | | | | | | | | |
| Capacitance tolerance | | Shall be satisfied allowance range. ±20% | As per 4.7 JIS C 5101-1 As per 4.5.2 JIS C 5101-3 Measuring frequency : 120±12Hz Measuring voltage : 0.5Vrms +1.5V.DC Measuring circuit : DC Equivalent series circuit | | | | | | | | | | | | | | | |
| Tangent of loss angle (Df, tan δ) | | Shall be satisfied the value on " Standard list " | As per 4.8 JIS C 5101-1 As per 4.5.3 JIS C 5101-3 Measuring frequency : 120±12Hz Measuring voltage : 0.5Vrms +1.5V.DC Measuring circuit : DC Equivalent series circuit | | | | | | | | | | | | | | | |
| ESR | | Shall be satisfied the value on " Standard list " | As per 4.10 JIS C 5101-1 As per 4.5.4 JIS C 5101-3 Measuring frequency : 100±10kHz Measuring voltage : 0.5Vrms or less Measuring circuit : DC Equivalent series circuit | | | | | | | | | | | | | | | |
| Resistance to Soldering heat | Appearance | There should be no significant abnormality. The indications should be clear. | As per 4.14 JIS C 5101-1 As per 4.6 JIS C 5101-3 Dip in the solder bath Solder temp : 240±5°C Duration : 10±0.5s Repetition : 1 After the specimens, leave it at room temperature for over 24h and then measure the sample. | | | | | | | | | | | | | | | |
| | L.C. | Less than 300% of initial limit | | | | | | | | | | | | | | | | |
| | ΔC / C | Within ±20% of initial value | | | | | | | | | | | | | | | | |
| | Df (tan δ) | Less than 300% of initial limit | | | | | | | | | | | | | | | | |
| Temperature cycle | Appearance | There should be no significant abnormality. The indications should be clear. | As per 4.16 JIS C 5101-1 As per 4.10 JIS C 5101-3 Repetition : 5 cycles (1 cycle : steps 1 to 4) without discontinuation. <table border="1" style="margin: 10px auto;"> <thead> <tr> <th></th> <th>Temp.</th> <th>Time</th> </tr> </thead> <tbody> <tr> <td>1</td> <td>-55±3°C</td> <td>30±3min.</td> </tr> <tr> <td>2</td> <td>Room temp.</td> <td>3min. or less</td> </tr> <tr> <td>3</td> <td>105±2°C</td> <td>30±3min.</td> </tr> <tr> <td>4</td> <td>Room temp.</td> <td>3min. or less</td> </tr> </tbody> </table> After the specimens, leave it at room temperature for over 24h and then measure the sample. | | Temp. | Time | 1 | -55±3°C | 30±3min. | 2 | Room temp. | 3min. or less | 3 | 105±2°C | 30±3min. | 4 | Room temp. | 3min. or less |
| | | Temp. | | Time | | | | | | | | | | | | | | |
| | 1 | -55±3°C | | 30±3min. | | | | | | | | | | | | | | |
| | 2 | Room temp. | | 3min. or less | | | | | | | | | | | | | | |
| 3 | 105±2°C | 30±3min. | | | | | | | | | | | | | | | | |
| 4 | Room temp. | 3min. or less | | | | | | | | | | | | | | | | |
| L.C. | Less than 1000% of initial limit | | | | | | | | | | | | | | | | | |
| ΔC / C | Within ±20% of initial value | | | | | | | | | | | | | | | | | |
| Df (tan δ) | Less than 300% of initial limit | | | | | | | | | | | | | | | | | |
| Moisture resistance | Appearance | There should be no significant abnormality. The indications should be clear. | As per 4.22 JIS C 5101-1 As per 4.12 JIS C 5101-3 After leaving the sample under such atmospheric condition that the temperature and humidity are 40±2°C and 90 to 95% RH, respectively, for 500±12h leave it at room temperature for over 24h and then measure the sample. | | | | | | | | | | | | | | | |
| | L.C. | Less than 300% of initial limit | | | | | | | | | | | | | | | | |
| | ΔC / C | Within +30/-20% of initial value | | | | | | | | | | | | | | | | |
| | Df (tan δ) | Less than 300% of initial limit | | | | | | | | | | | | | | | | |

| Item | | Performance | Test conditions (based on JIS C 5101-1 and JIS C 5101-3) |
|-----------------------------|-------------|--|--|
| Temperature Stability | Temp. | -55°C | As per 4.29 JIS C 5101-1 As per 4.13 JIS C 5101-3 |
| | ΔC / C | Within 0/-20% of initial value | |
| | Df (tan δ) | Shall be satisfied the value on " Standard list " | |
| | L.C. | - | |
| | Temp. | +105°C | |
| | ΔC / C | Within +50/0% of initial value | |
| | Df (tan δ) | Shall be satisfied the value on " Standard list " | |
| | L.C. | Less than 1,000% of initial limit | |
| Surge voltage | Appearance | There should be no significant abnormality. | As per 4.26 JIS C 5101-1 As per 4.14 JIS C 5101-3 Apply the specified surge voltage via the serial resistance of 1kΩ ever 5±0.5 min. for 30±5 s. each time in the atmospheric condition of 85±2°C. Repeat this procedure 1,000 times. After the specimens, leave it at room temperature for over 24h and then measure the sample. |
| | L.C. | Less than 200% of initial limit | |
| | ΔC / C | Within ±20% of initial value | |
| | Df (tan δ) | Less than 200% of initial limit | |
| Loading at High temperature | Appearance | There should be no significant abnormality. The indications should be clear. | As per 4.23 JIS C 5101-1 As per 4.15 JIS C 5101-3 After applying the rated voltage for 1000+72/0 h without discontinuation via the serial resistance of 3Ω or less at a temperature of 85±2°C, leave the sample at room temperature / humidity for over 24h and measure the value. |
| | L.C. | Less than 400% of initial limit | |
| | ΔC / C | Within ±20% of initial value | |
| | Df (tan δ) | Less than 300% of initial limit | |
| Terminal strength | Capacitance | The measured value should be stable. | As per 4.35 JIS C 5101-1 As per 4.9 JIS C 5101-3 A force is applied to the terminal until it bends to 1mm and by a prescribed tool maintain the condition for 5s. (See the figure below) |
| | Appearance | There should be no significant abnormality. | |
| | | | |
| Adhesiveness | | The terminal should not come off. | As per 4.34 JIS C 5101-1 As per 4.8 JIS C 5101-3 Apply force of 5N in the two directions shown in the figure below for 10±1s after mounting the terminal on a circuit board. |
| | | | |
| Dimensions | | Refer to "External dimensions" | Measure using a caliper of JIS B 7507 Class 2 or higher grade. |
| Resistance to solvents | | The indication should be clear. | As per 4.32 JIS C 5101-1 As per 4.18 JIS C 5101-3 Dip in the isopropyl alcohol for 30±5s, at room temperature. |
| Solderability | | 3/4 or more surface area of the solder coated terminal dipped in the soldering bath should be covered with the new solder. | As per 4.15.2 JIS C 5101-1 As per 4.7 JIS C 5101-3 Dip speed=25±2.5mm / s Pre-treatment (accelerated aging): Leave the sample on the boiling distilled water for 1 h. Solder temp. : 245±5°C Duration : 3±0.5s Solder : M705 Flux : Rosin 25% IPA 75% |
| Vibration | Capacitance | Measure value should not fluctuate during the measurement. | As per 4.17 JIS C 5101-1 Frequency : 10 to 55 to 10Hz/min. Amplitude : 1.5mm Time : 2h each in X and Y directions Mounting : The terminal is soldered on a print circuit board. |
| | Appearance | There should be no significant abnormality. | |

● Standard products list, TCTO series A case

| Part No. | Rated voltage 85°C (V) | Category voltage 105°C (V) | Surge voltage 85°C (V) | Cap. 120Hz (μF) | Tolerance (%) | Leakage current 25°C 1WV.5min (μA) | Df 120Hz (%) | | | ESR 100kHz (mΩ) |
|---------------------|------------------------------|-------------------------------------|---------------------------------|-----------------------|------------------|--|--------------------|--------------|-------|-----------------------|
| | | | | | | | -55°C | 25°C 85°C | 105°C | |
| TCTO A 0E 227 M8R | 2.5 | 2.0 | 3.2 | 220 | ± 20 | 55.0 | 15 | 15 | 20 | 200 |
| * TCTO A 0E 337 M8R | 2.5 | 2.0 | 3.2 | 330 | ± 20 | 82.5 | 15 | 15 | 20 | 200 |
| TCTO A 0G 157 M8R | 4 | 3.2 | 5 | 150 | ± 20 | 60.0 | 15 | 15 | 20 | 200 |
| * TCTO A 0G 227 M8R | 4 | 3.2 | 5 | 220 | ± 20 | 88.0 | 15 | 15 | 20 | 200 |
| TCTO A 0J 107 M8R | 6.3 | 5 | 8 | 100 | ± 20 | 63.0 | 15 | 15 | 20 | 200 |
| TCTO A 0J 157 M8R | 6.3 | 5 | 8 | 150 | ± 20 | 94.5 | 15 | 15 | 20 | 200 |
| TCTO A 1A 476 M8R | 10 | 8 | 13 | 47 | ± 20 | 47.0 | 10 | 10 | 15 | 200 |
| * TCTO A 1A 686 M8R | 10 | 8 | 13 | 68 | ± 20 | 68.0 | 15 | 15 | 20 | 200 |
| * TCTO A 1C 106 M8R | 16 | 12.8 | 20 | 10 | ± 20 | 16.0 | 10 | 10 | 15 | 200 |

* = Under development

Please contact us for specification of low ESR products.

● Packaging specifications

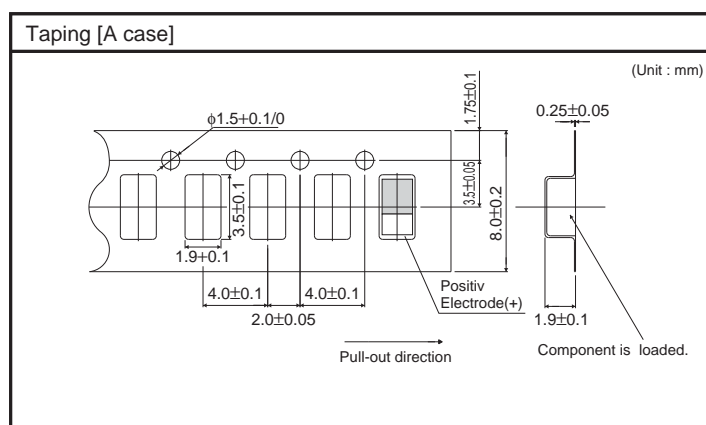

● Packaging style

| Case code | Packaging | Packaging style | | Symbol | Basic ordering units |
|-----------|-----------|-----------------|-------------|--------|----------------------|
| A case | Taping | plastic taping | φ180mm Reel | R | 2,000pcs |

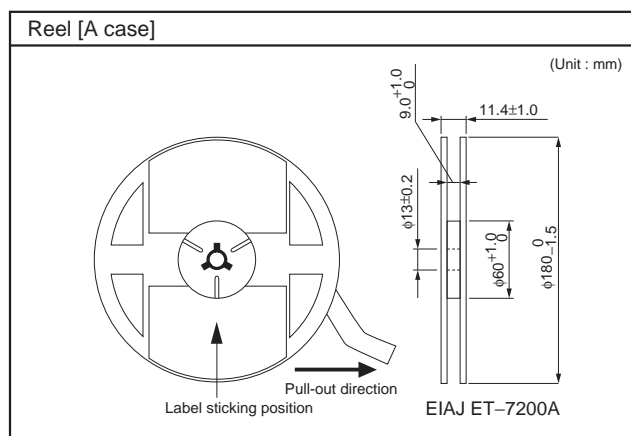

● Damp proof package

- ① One reel is packed in aluminum bag.
The size of aluminum bag is 240(a) x 250(b)mm.
The size up to 230(c)mm is to zipper.
- ② A desiccant is packed with a reel.
- ③ The aluminum bag is heat-sealed.
- ④ The label of the same as the label on the reel is placed on the aluminum bag.

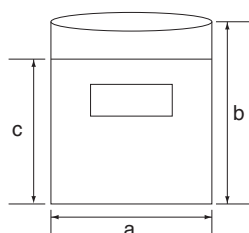

Notes

No copying or reproduction of this document, in part or in whole, is permitted without the consent of ROHM Co.,Ltd.

The content specified herein is subject to change for improvement without notice.

The content specified herein is for the purpose of introducing ROHM's products (hereinafter "Products"). If you wish to use any such Product, please be sure to refer to the specifications, which can be obtained from ROHM upon request.

Examples of application circuits, circuit constants and any other information contained herein illustrate the standard usage and operations of the Products. The peripheral conditions must be taken into account when designing circuits for mass production.

Great care was taken in ensuring the accuracy of the information specified in this document. However, should you incur any damage arising from any inaccuracy or misprint of such information, ROHM shall bear no responsibility for such damage.

The technical information specified herein is intended only to show the typical functions of and examples of application circuits for the Products. ROHM does not grant you, explicitly or implicitly, any license to use or exercise intellectual property or other rights held by ROHM and other parties. ROHM shall bear no responsibility whatsoever for any dispute arising from the use of such technical information.

The Products specified in this document are intended to be used with general-use electronic equipment or devices (such as audio visual equipment, office-automation equipment, communication devices, electronic appliances and amusement devices).

The Products specified in this document are not designed to be radiation tolerant.

While ROHM always makes efforts to enhance the quality and reliability of its Products, a Product may fail or malfunction for a variety of reasons.

Please be sure to implement in your equipment using the Products safety measures to guard against the possibility of physical injury, fire or any other damage caused in the event of the failure of any Product, such as derating, redundancy, fire control and fail-safe designs. ROHM shall bear no responsibility whatsoever for your use of any Product outside of the prescribed scope or not in accordance with the instruction manual.

The Products are not designed or manufactured to be used with any equipment, device or system which requires an extremely high level of reliability the failure or malfunction of which may result in a direct threat to human life or create a risk of human injury (such as a medical instrument, transportation equipment, aerospace machinery, nuclear-reactor controller, fuel-controller or other safety device). ROHM shall bear no responsibility in any way for use of any of the Products for the above special purposes. If a Product is intended to be used for any such special purpose, please contact a ROHM sales representative before purchasing.

If you intend to export or ship overseas any Product or technology specified herein that may be controlled under the Foreign Exchange and the Foreign Trade Law, you will be required to obtain a license or permit under the Law.



Thank you for your accessing to ROHM product informations.
More detail product informations and catalogs are available, please contact us.

ROHM Customer Support System

<http://www.rohm.com/contact/>