

IrDA Infrared Communication Module

RPM971-H14

RPM971-H14 is an infrared communication module for IrDA Ver. 1.4 (Low Power). The infrared LED, PIN photo diode, and waveform shaping LSI are all integrated into one single package. This module is designed for low power consumption. The very small package makes it a perfect fit for mobile devices.

●Features

- 1) Infrared LED, PIN photo diode, LED driver and receiver frequency formation circuit built in.
Improvement of EMI noise protection by Shield Case.
- 2) Applied to SIR (9.6k to 115.2kbps), MIR (0.576M, 1.152Mbps) and FIR(4Mbps).
- 3) Surface mount type.
- 4) Power down function built in.
- 5) Adjustable communication distance by LED load resistance value.

●Applications

Cellular phone, PDA, DVC, Digital still camera, Printer, Handy terminal etc.

●Absolute maximum ratings (Ta=25°C)

Parameter	Symbol	Limits	Units
Supply voltage	V _{CC} /V _{LEDA} /V _{IO}	6.5 *1	V
Input voltage	V _{in} (3,4,5pin)	-0.3 to V _{IO} +0.3	V
Operation temperature	T _{opr}	-25 to 85	°C
Storage temperature	T _{stg}	-30 to 100	°C
LED peak current	I _{fp}	400 *2	mA
Power dissipation	P _d	300 *3	mW

*1) This applies to all pins basis ground pin (8pin).

*2) LED Peak Current : < 90 μs, On duty < 25%

*3) When glass-epoxy board (70x70x1.6mm) mounted. In case of operating environment is over 25°C, 4mW would be reduced per each 1°C stepping up.

●Recommended operating conditions

Parameter	Symbol	Min.	Typ.	Max.	Units
Supply voltage	V _{CC}	2.4	3.0	3.6	V
	V _{LEDA}	2.7	3.0	5.5	V
	V _{IO}	1.7	3.0	V _{CC}	V

Photo Link Module

●Terminal description

Pin No	Terminal	Circuit	Function
1	LEDA		LED Anode Terminal Other power source can be used difference between LEDV _{CC} and V _{CC} . LED current depends on LED load resistance value. Include internal current limiter (max.400mA).
2	NC		NC This terminal must be left open.
3	TXD		Transmitting Data Input Terminal H:LED radiant (PWDOWN=L) CMOS Logic Level Input. Holding TXD="H" status, LED will be turn off approximately 48 μs.
4	RXD		Receiving Data Output Terminal When PWDOWN(5pin)="H", the RXD output will be pulled up to V _{IO} at approximately 300 kΩ.
5	PWDOWN /Mode		Power-down Control and Mode Setting Terminal H: POWERDOWN L : OPERATION CMOS Logic Level Input. When input is "H", it will stop the receiving circuit, Pin-PD current and transmitting LED operation.
6	V _{CC}		V_{CC} Supply voltage for Transceiver circuits. For preventing from infection, connect a capacitor between GND(8pin).
7	V _{IO}		V_{IO} Supply voltage for I / O pins (PWDOWN,RXD,TXD).
8	GND		GROUND
-	Shield Case		Connect to Ground.

Photo Link Module

●Electrical characteristics (Unless otherwise noted, $V_{CC}=3V$, $V_{LEDV_{CC}}=3V$, $V_{IO}=3V$, $T_a=25^{\circ}C$)

Parameter	Symbol	Min.	Typ.	Max.	Unit	Conditions
Consumption current 1(SMIR mode)	I _{cc1}	400	800	1600	μA	PWDOWN=0V, At no input light
Consumption current 2(FIR mode)	I _{cc2}	400	1000	1600	μA	PWDOWN=0V, At no input light
Consumption current 3(at PWDOWN)	I _{cc3}	–	0.01	0.2	μA	PWDOWN=V _{IO} , At no input light
Transmission rate		0.0096	–	4	Mbps	
PWDOWN input high voltage	V _{PDH}	2/3*V _{IO}	–	V _{IO}	V	V _{IO} =1.7 to 3.6 V (V _{IO} ≤ V _{CC})
PWDOWN input low voltage	V _{PDL}	0	–	1/3*V _{IO}	V	
PWDOWN input high current	I _{PDH}	–1.0	0	1.0	μA	PWDOWN=V _{IO}
PWDOWN input low current	I _{PDL}	–1.0	0	1.0	μA	PWDOWN=0V

< Transmitter >

TXD input high voltage	V _{TXH}	2/3*V _{IO}	–	V _{IO}	V	V _{IO} =1.7 to 3.6 V (V _{IO} ≤ V _{CC})
TXD input low voltage	V _{TXL}	0	–	1/3*V _{IO}	V	
TXD input high current	I _{TXH}	2.5	5	10	μA	TXD=V _{IO}
TXD input low current	I _{TXL}	–1.0	0	1.0	μA	TXD=0V
LED anode current	I _{LED1}	–	170	–	mA	R1=5.6Ω

< Receiver >

RXD output high voltage	V _{RXH}	V _{IO} –0.4	–	V _{IO}	V	IRXH= –200μA
RXD output low voltage	V _{RXL}	0	–	0.4	V	IRXL=200μA
RXD output rise time	t _{RR}	–	20	–	ns	C _L =15pF
RXD output fall time	t _{FR}	–	20	–	ns	C _L =15pF
RXD output pulse width(SIR)	t _{wRXDS}	1.0	2.3	4.0	μs	C _L =15pF, 9.6k to 115.2 kbps, duty19%
RXD output pulse width(MIR1)	t _{wRXDM1}	200	434	800	ns	C _L =15pF, 0.576 Mbps, duty25%
RXD output pulse width(MIR2)	t _{wRXDM2}	100	217	500	ns	C _L =15pF, 1.152 Mbps, duty25%
RXD output pulse width(FIR1)	t _{wRXDF1}	85	125	165	ns	C _L =15pF, 4 Mbps(125ns pulse)
RXD output pulse width(FIR2)	t _{wRXDF2}	195	250	290	ns	C _L =15pF, 4 Mbps(250ns pulse)
Receiver latency time	t _{RT}	–	100	200	μs	

●Optical characteristics (Unless otherwise noted, $V_{CC}=3V$, $V_{LEDV_{CC}}=3V$, $V_{IO}=3V$, $T_a=25^{\circ}C$)

Parameter	Symbol	Min.	Typ.	Max.	Unit	Conditions
Peak wave length	λ _P	850	870	900	nm	
Intensity	IE	25	63	–	mW/sr	–15 deg ≤ θ _L ≤ 15 deg R1=5.6Ω
Half-angle	θ _L / 2	–	±18	–	deg	
Rise time / Fall time	T _r / T _f	–	–	40	ns	10% to 90%
Optical over shoot		–	–	25	%	
Edge jitter	T _j	–25	–	25	ns	
Optical pulse width(MIR)	T _{wE} M	172	217	256	ns	t _{TXD} =217ns
Optical pulse width(FIR)	T _{wE} F	115	125	135	ns	t _{TXD} =125ns
Minimum irradiance in angular1	E _{emin1}	–	–	8	μW/cm ²	–15 deg ≤ θ _L ≤ 15 deg, ≤ 115.2kbps
Minimum irradiance in augular2	E _{emin2}	–	–	20	μW/cm ²	–15 deg ≤ θ _L ≤ 15 deg, > 115.2kbps
Maximum irradiance in augular	E _{emax}	500	–	–	mW/cm ²	–15 deg ≤ θ _L ≤ 15 deg
Input half-angle	θ _D / 2	±15	–	–	deg	
Maximum emitting time	T _{LED} max	16	48	120	μs	TXD=V _{IO}

1. This product is not designed for protection against radioactive rays.
2. This product dose not include laser transmitter.
3. This product includes one PIN photo diode.
4. This product dose not include optical load.

Photo Link Module

●Timing chart

1. Mode Setting (SIR / MIR / FIR)

With RPM971-H14 there is a need for mode switch according to communication rate. For the mode setting, there are "PWDOWN/Mode" and "TXD". Please see below diagram for the set up of mode.

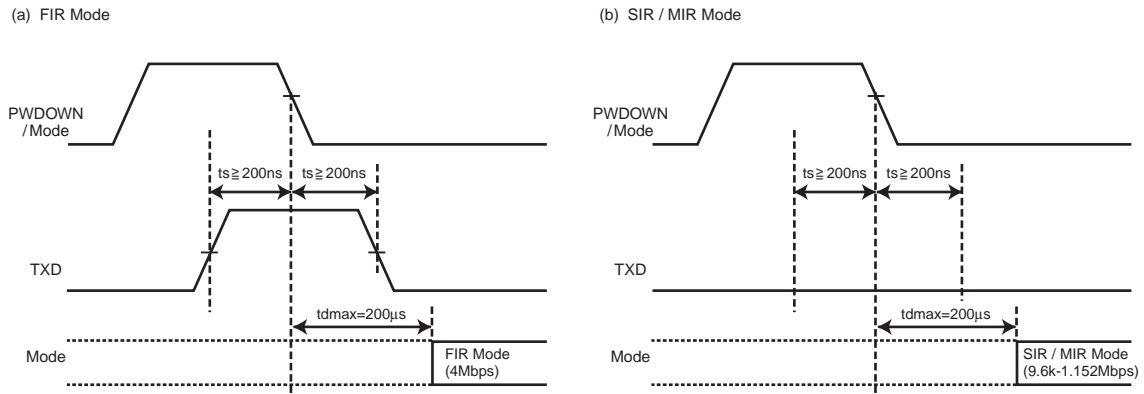

Fig. 1

2. Timing chart (use example)

(a) Emitting

When a pulse is inputted to TXD terminal, LED is emitting, and a signal is transmitted.

But, when "H" condition follows TXD terminal, LED turns off the lights in the range of TLEDmax.

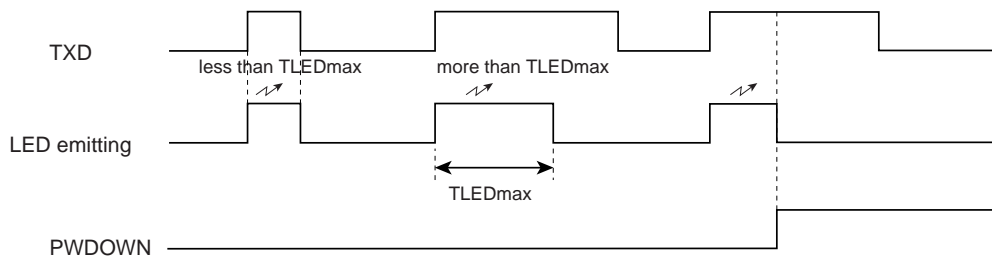

Photo Link Module

(b) Detecting

When it is received an optical signal, a signal outputs from RXD terminal at the following timing.

It is outputted in the pulse width fixed at the time of SIR mode (9.6k to 115.2kbps).

It is outputted in the pulse width which is the same as the input signal at the time of MIR mode (0.576M, 1.152Mbps) and FIR mode (4Mbps).

But, as for the pulse width of the input signal, it is based on IrDA Physical Layer Specification.

① SIR mode (output example)

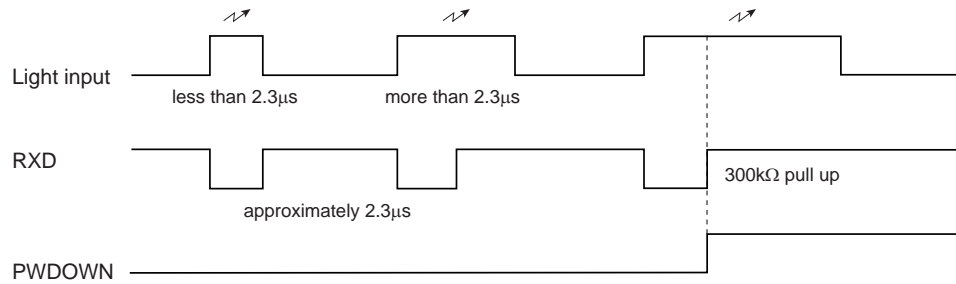

② MIR mode (output example)

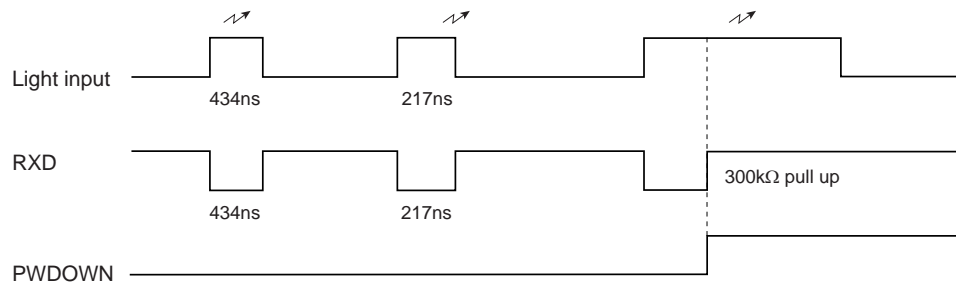

③ FIR mode (output example)

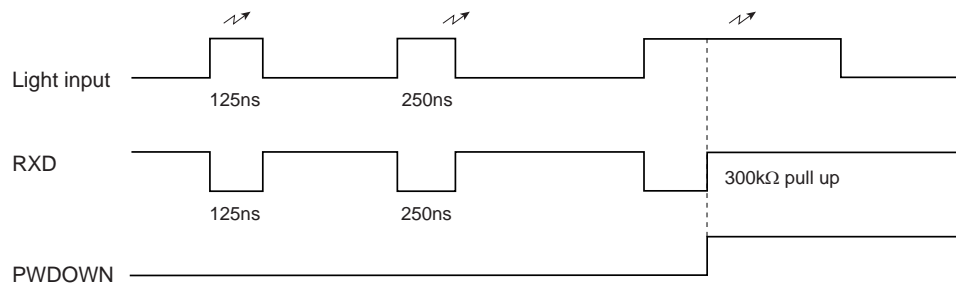

Photo Link Module

●External dimensions (Unit : mm)

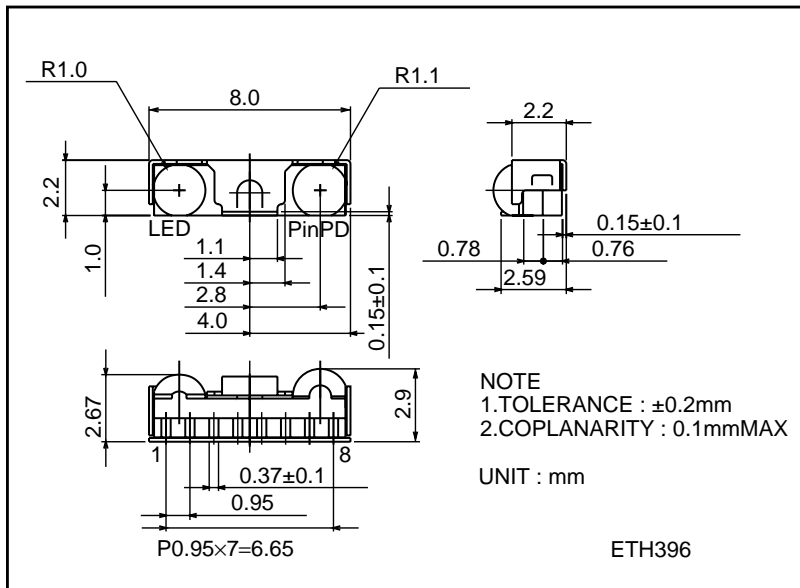
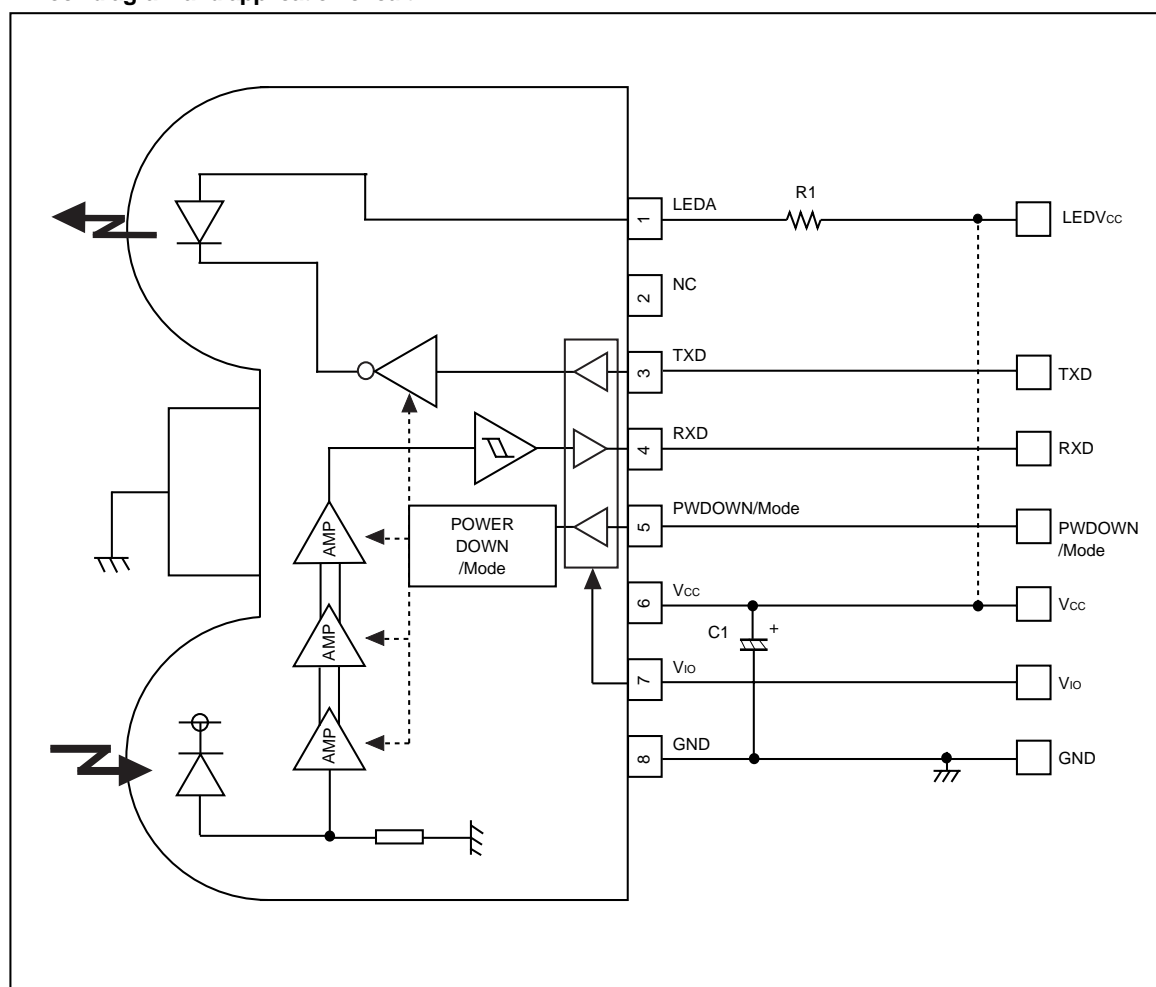

Photo Link Module

●Block diagram and application circuit



●Attached components

Part symbol	Recommended value	Notice
C1	6.8μF, Ceramic or tantalum Ex.)TCFGA1A685M8R(ROHM)	Bigger capacitance is recommended with much noise from power supply.
R1	5.6Ω ±5%, 1/4W (LEDV _{cc} =3.0V) 10Ω ±5%, 1/4W (LEDV _{cc} =3.7V) 18Ω ±5%, 1/4W (LEDV _{cc} =5.0V)	Including LED's distribution within ±15deg.

In case of using R1 with different condition from the above, formula is as follows :

LED resistance value : R1 [Ω], LED average consumption current : I_{LED} [mA], Supply voltage : V_{LEDV_{cc}} [V], minimum necessary of irradiant intensity I_{e1} [mW / sr]

$$R1 = 170 \times (V_{LEDV_{cc}} - 1.45) / I_{e1} - 5 \text{ [}\Omega\text{]}$$

$$I_{LED} = \text{Duty} \times (V_{LEDV_{cc}} - 1.36) / (R1 + 4) \text{ [A]}$$

Duty : LED duty at emitting

* Please set up to be I_{LED} < 180[mA] (Duty ≤ 25%).

Photo Link Module

●Notes

1) VLEDV_{CC} (1pin), V_{CC} (6pin) and V_{IO} (7pin)

- There is no problem even if it is supplied separately from each power supply such as a fix voltage power supply and a battery power supply.

But, use it in the recommendation power supply voltage range.

2) Caution in designing board lay-out

To get maximum potential from RPM971-H14, please keep in mind following instruction.

- The line of RXD (4pin) should be connected at backside via through hole close to RPM971-H14 pin lead. Better not to be close to photo diode side (8pin side).

⇒This is to minimize feedback supplied to photo diode from RXD.

- The parts which generate noise such as DC / DC converter should be one's placed at more than a radius of 1.0cm away from photo diode (8pin side).
- As for C1 between 6 - 8 pins, it should be one's placed close to RPM971-H14.

3) Notes

- Please be sure to set up the TXD (3pin) input to be "L" (under 0.6V) except transmitting data.
(For < 90μ sec. ON duty < 25%).
- Powerdown current might increase if exposed by strong light (ex. direct sunlight) at powerdown mode.
- Please use by the signal format which is specified by IrDA Ver1.3 (Low Power).
There might be on error if used by different signal format.

<Communication rate and pulse continuous time>

Signaling Rate	Modulation	Rate Tolerance % of Rate	Pulse Duration Minimum	Pulse Duration Nominal	Pulse Duration Maximum	
2.4kbit/s	RZI	+/- 0.87	1.41μs	78.13μs	88.55μs	
9.6kbit/s	RZI	+/- 0.87	1.41μs	19.53μs	22.13μs	
19.2kbit/s	RZI	+/- 0.87	1.41μs	9.77μs	11.07μs	
38.4kbit/s	RZI	+/- 0.87	1.41μs	4.88μs	5.96μs	
57.6kbit/s	RZI	+/- 0.87	1.41μs	3.26μs	4.34μs	
115.2kbit/s	RZI	+/- 0.87	1.41μs	1.63μs	2.23μs	
0.576Mbit/s	RZI	+/- 0.1	295.2ns	434.0ns	520.8ns	
1.152Mbit/s	RZI	+/- 0.1	147.6ns	217.0ns	260.4ns	
4.0Mbit/s	single pulse	4PPM	+/- 0.01	115.0ns	125.0ns	135.0ns
	double pulse	4PPM	+/- 0.01	240.0ns	250.0ns	260.0ns

- Please pay attention to the lens carefully.
Dusts or scratch on the lens may effect the characteristics of product, please handle it with care.

4) Eye safe

- Eye safe is based on EN60825-1(IEC60825-1 amendment 2), Class1 Eye safe.

Notes

- No technical content pages of this document may be reproduced in any form or transmitted by any means without prior permission of ROHM CO.,LTD.
- The contents described herein are subject to change without notice. The specifications for the product described in this document are for reference only. Upon actual use, therefore, please request that specifications to be separately delivered.
- Application circuit diagrams and circuit constants contained herein are shown as examples of standard use and operation. Please pay careful attention to the peripheral conditions when designing circuits and deciding upon circuit constants in the set.
- Any data, including, but not limited to application circuit diagrams information, described herein are intended only as illustrations of such devices and not as the specifications for such devices. ROHM CO.,LTD. disclaims any warranty that any use of such devices shall be free from infringement of any third party's intellectual property rights or other proprietary rights, and further, assumes no liability of whatsoever nature in the event of any such infringement, or arising from or connected with or related to the use of such devices.
- Upon the sale of any such devices, other than for buyer's right to use such devices itself, resell or otherwise dispose of the same, no express or implied right or license to practice or commercially exploit any intellectual property rights or other proprietary rights owned or controlled by
- ROHM CO., LTD. is granted to any such buyer.
- Products listed in this document are no antiradiation design.

The products listed in this document are designed to be used with ordinary electronic equipment or devices (such as audio visual equipment, office-automation equipment, communications devices, electrical appliances and electronic toys).

Should you intend to use these products with equipment or devices which require an extremely high level of reliability and the malfunction of which would directly endanger human life (such as medical instruments, transportation equipment, aerospace machinery, nuclear-reactor controllers, fuel controllers and other safety devices), please be sure to consult with our sales representative in advance.

About Export Control Order in Japan

Products described herein are the objects of controlled goods in Annex 1 (Item 16) of Export Trade Control Order in Japan.

In case of export from Japan, please confirm if it applies to "objective" criteria or an "informed" (by MITI clause) on the basis of "catch all controls for Non-Proliferation of Weapons of Mass Destruction.