

# IrDA wireless communication transceiver IC (supports Ver. 1.2 Low Power)

## RPM870-H14

The RPM870-H14 is an Module that supports IrDA Ver. 1.2 (Low Power), and is ideal for wireless communications. An infrared LED, a pin-photo diode, and LSI are all contained in a very small single package. It is also equipped with low power consumption and power down functions making this IC perfect for mobile sets.

### ●Features

- 1) Applied to IrDA Ver. 1.2. (Low Power)
- 2) Low power consumption while waiting mode. (90 $\mu$ A Typ.)
- 3) A power-down function is perfect for battery applications.
- 4) Supports a board power supply voltage range from 2.6V to 3.6V.
- 5) Only 1 external capacitor required.

### ●Applications

Mobile phones, PDAs, and others

### ●Absolute maximum ratings (Ta = 25°C)

Parameter	Symbol	Limits	Unit
Supply voltage	V <sub>CC</sub>	7.0	V
Input voltage	V <sub>IN</sub>	-0.3 to V <sub>CC</sub> +0.3	V
Operating temperature	T <sub>opr</sub>	-20 to +85	°C
Storage temperature	T <sub>stg</sub>	-30 to +100	°C
Power dissipation	P <sub>d</sub>	100	mW

### ●Recommended operating conditions (Ta = 25°C)

Parameter	Symbol	Min.	Typ.	Max.	Unit
Supply voltage	V <sub>CC</sub>	2.6	3.0	3.6	V
	V <sub>LEDA</sub>	2.6	3.0	5.5	V

Photo Link Module

●Block diagram and application circuit

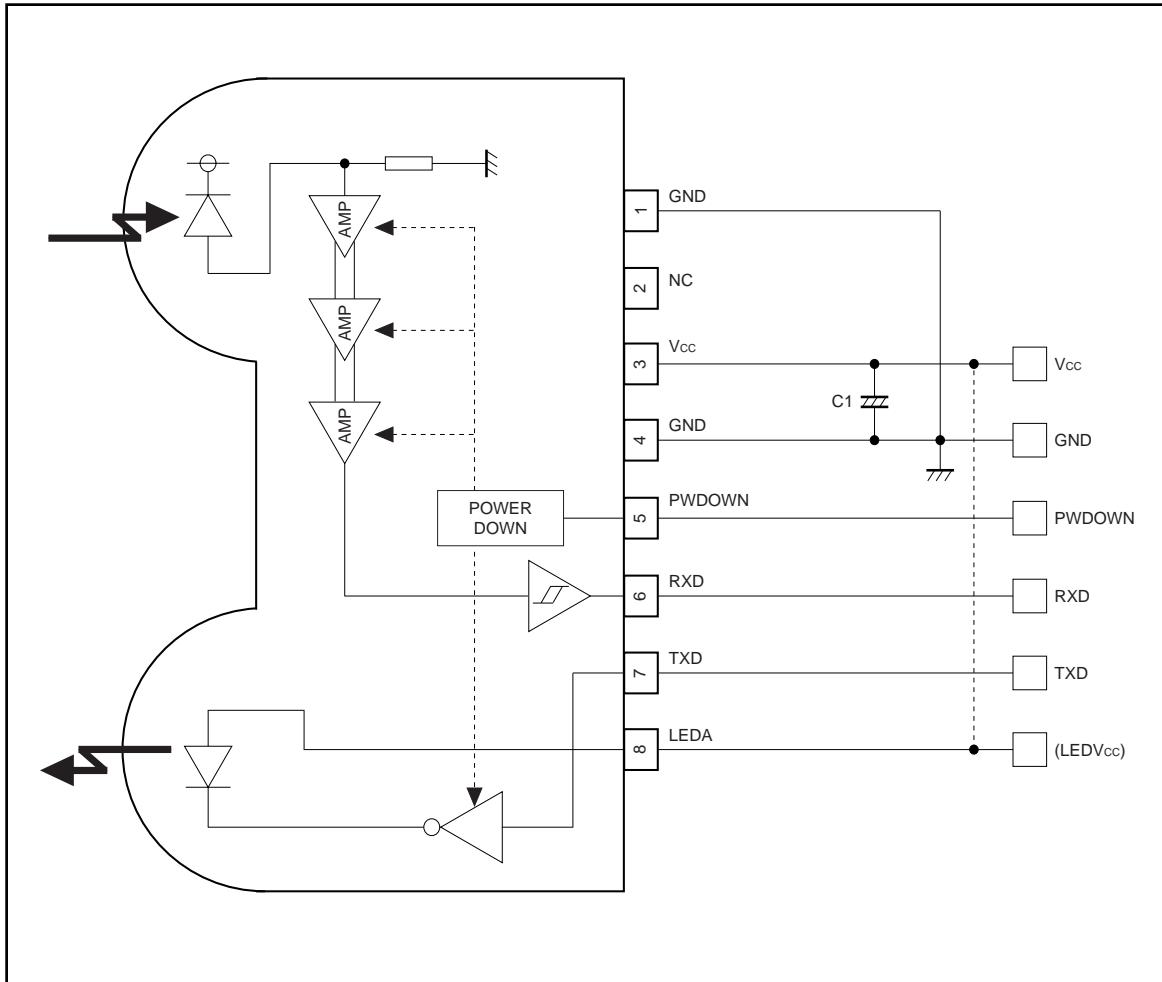

Recommended values

Part symbol	Recommended value	Notice
C1	1 $\mu$ F, tantalum Ex.) TCFG1A105M8R (ROHM)	Bigger capacitance is recommended with much noise from power supply

## Photo Link Module

## ●Terminal description

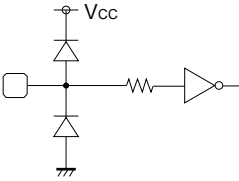
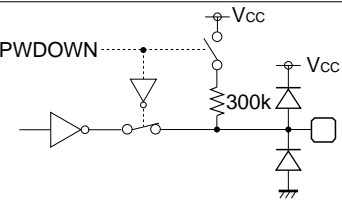
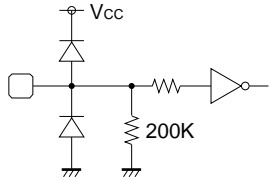
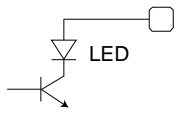
Pin No	Terminal	Circuit	Function
1, 4	GND		GND
2	NC		This terminal must be left open.
3	Vcc		Vcc For preventing from ripple noise. connect a capacitor between Vcc (3pin) and GND (4pin).
5	PWDOWN		Power-down control terminal H : POWERDOWN L : OPERATION CMOS logic level input When input is H, it will stop the receiving circuit, Pin-PD current and transmitting LED operation.
6	RXD		Receiving data output terminal CMOS logic level input When PWDOWN (5pin) = H, the RXD output will be pulled up to Vcc at approximately 300kΩ.
7	TXD		Transmitting data input terminal H : LED Drive (PWDOWN = L) CMOS logic level output Holding TXD = "H" status, LED will be turn off approximately 48μsec.
8	LEDA		LED ANODE terminal Other power source can be used difference between LEDVcc and Vcc.

## Photo Link Module

●Electrical characteristics (Unless otherwise noted,  $V_{CC}=3V$ ,  $V_{LEDV_{CC}}=3V$ ,  $T_a=25^{\circ}C$ )

Parameter	Symbol	Min.	Typ.	Max.	Unit	Conditions
Consumption Current 1	I <sub>cc1</sub>	–	90	120	μA	Waiting mode, no input light.
Consumption Current 2	I <sub>cc2</sub>	–	0.01	0.2	μA	PWDOWN= $V_{CC}$ [V], no input light.
Transmission rate		2.4	–	115.2	kbps	
PWDOWN INPUT High Voltage	VPDH	$V_{CC}-0.5$	–	–	V	
PWDOWN INPUT Low Voltage	VPDL	–	–	0.55	V	
PWDOWN INPUT High Current	IPDH	–1.0	0	1.0	μA	PWDOWN= $V_{CC}$ [V]
PWDOWN INPUT Low Current	IPDL	–1.0	0	1.0	μA	PWDOWN=0 [V]
<b>&lt;Transmitter&gt;</b>						
TXD INPUT High Voltage	V <sub>TXH</sub>	$V_{CC}-0.55$	–	–	V	
TXD INPUT Low Voltage	V <sub>TXL</sub>	–	–	0.55	V	
TXD INPUT High Current	I <sub>TXH</sub>	7.5	15	30	μA	TXD= $V_{CC}$ [V]
TXD INPUT Low Current	I <sub>TXL</sub>	–1.0	0	1.0	μA	TXD=0 [V]
LED ANODE Current	I <sub>LEDA</sub>	–	50	–	mA	
<b>&lt;Receiver&gt;</b>						
RXD OUTPUT High Voltage	V <sub>RXH</sub>	$V_{CC}-0.5$	–	–	V	I <sub>RXH</sub> =–50μA
RXD OUTPUT Low Voltage	V <sub>RXL</sub>	–	–	0.4	V	I <sub>RXL</sub> =200μA
RXD OUTPUT Rise Time	t <sub>RR</sub>	–	70	–	nsec	C <sub>L</sub> =15pF
RXD OUTPUT Fall Time	t <sub>FR</sub>	–	30	–	nsec	C <sub>L</sub> =15pF
RXD OUTPUT Pulse Width	t <sub>WRXD</sub>	1.5	2.3	3.6	μsec	C <sub>L</sub> =15pF, 2.4 to 115.2Kbps
Receiver Latency Time	t <sub>RT</sub>	–	100	200	μsec	

●Optical characteristics (Unless otherwise noted,  $V_{CC}=3V$ ,  $V_{LEDV_{CC}}=3V$ ,  $T_a=25^{\circ}C$ )

Parameter	Symbol	Min.	Typ.	Max.	Unit	Conditions
Peak wave length	$\lambda_P$	850	870	900	nm	
Intensity	I <sub>E1</sub>	4.0	10	26	mW / sr	$-15^{\circ} \leq \theta_L \leq 15^{\circ}$
Half-Angle	$\theta_L / 2$	$\pm 15$	–	–	deg	
Rise time / Fall time	T <sub>r</sub> / T <sub>f</sub>	–	–	100	nsec	10% to 90%
Optical over shoot		–	–	25	%	
Edge jitter	T <sub>j</sub>	–40	–	40	nsec	
Irradiance in angular	E <sub>e</sub>	0.0068	–	500	mW / cm <sup>2</sup>	$-15^{\circ} \leq \theta_L \leq 15^{\circ}$
INPUT Half-Angular	$\theta_D / 2$	$\pm 15$	–	–	deg	
Maximum Emitting Time	T <sub>LEDmax</sub>	16	48	96	μsec	TXD= $V_{CC}$

1.This product is not designed for protection against radioactive rays.

2.This product dose not include laser transmitter.

3.This product includes one pin photo diode.

4.This product dose not include optical load.

## Photo Link Module

## ●Timing chart

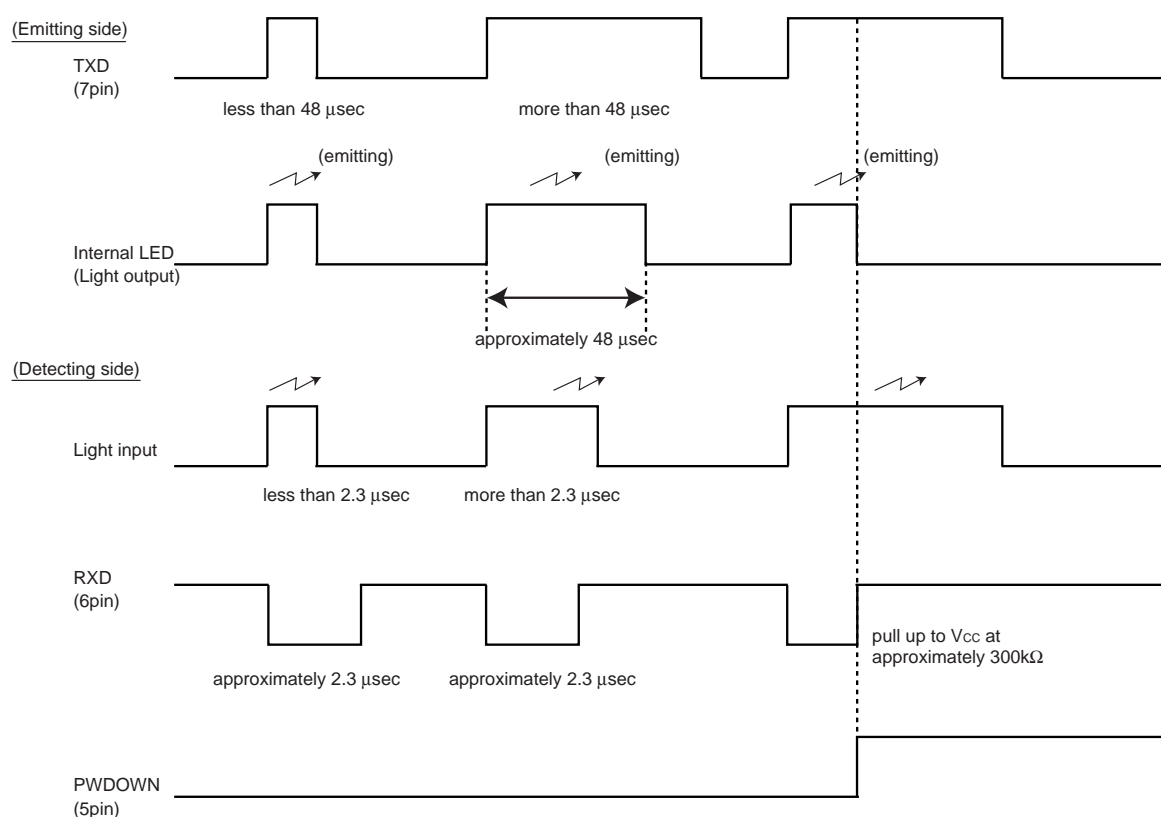

## ●Notes

- 1) LEDV<sub>CC</sub> (8pin) and V<sub>CC</sub> (3pin)
  - Other power source can be used difference between LEDV<sub>CC</sub> and V<sub>CC</sub>.
- 2) Caution in designing board lay-out
 

To get maximum potential from RPM870-H14, please keep in mind following instruction.

  - The line of RXD (6pin) should be connected at backside via through hole close to RPM870-H14 pin lead. Better not to be close to photo diode side (1pin).
  - ⇒ This is to minimize feedback supplied to photo diode from RXD.
  - As for C1 between 3-4 pin should be placed close to RPM870-H14.
  - Better to be placed more than 1.0cm in radius from photo diode (pin1 side) and also away from the parts which generates noise, such as DC / DC converter.
- 3) Others
  - Please be sure to set up the TXD (7pin) input to be "L" (under 0.5V) except transmitting data (for < 90μsec. on duty < 20%).
  - Powerdown current might increase if exposed by strong light (ex. direct sunlight) at powerdown mode.
  - Please use by the signal format which is specified by IrDA Ver1.2 (Low Power). There might be on error if used by different signal format.
  - Please pay attention to the lens carefully. Dusts of scratch on the lens may effect the characteristics of product. Please handle it with care.
- 4) Eye Safe
  - IEC825-1 (EN60825-1) Class 1 Eye Safe.

Photo Link Module

●Dimensions (Unit : mm)

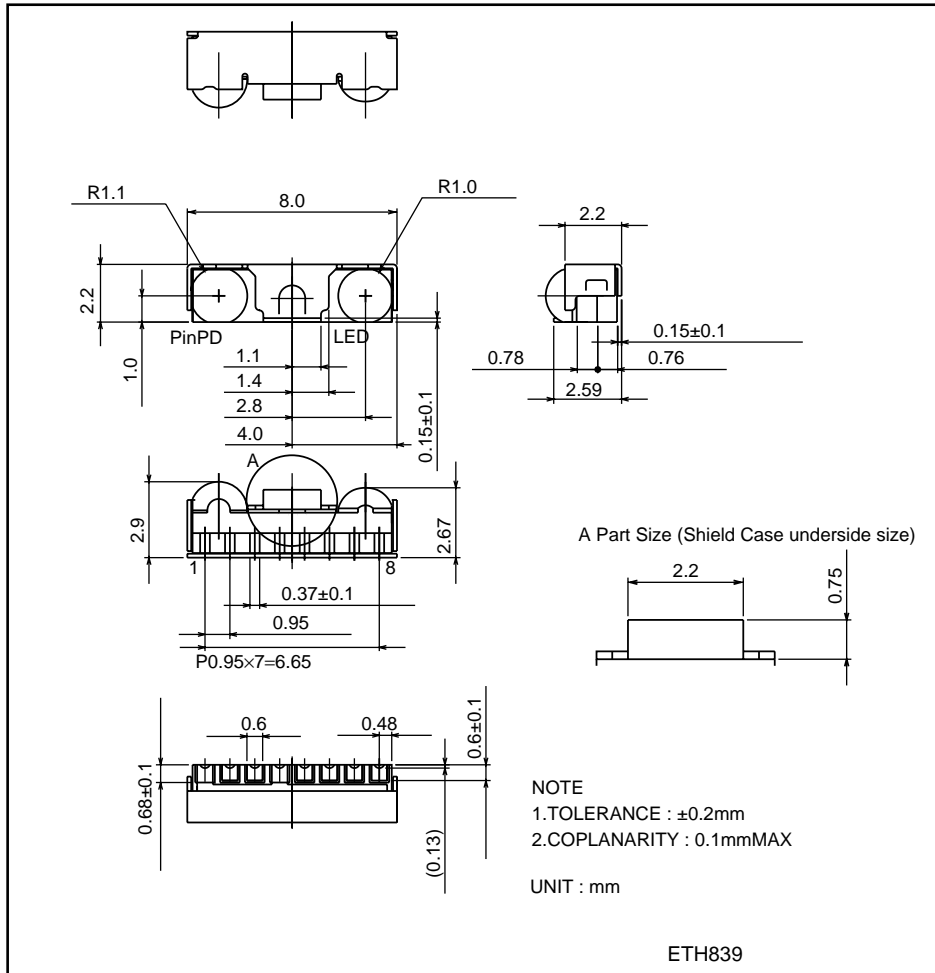

### Notes

- No technical content pages of this document may be reproduced in any form or transmitted by any means without prior permission of ROHM CO.,LTD.
- The contents described herein are subject to change without notice. The specifications for the product described in this document are for reference only. Upon actual use, therefore, please request that specifications to be separately delivered.
- Application circuit diagrams and circuit constants contained herein are shown as examples of standard use and operation. Please pay careful attention to the peripheral conditions when designing circuits and deciding upon circuit constants in the set.
- Any data, including, but not limited to application circuit diagrams information, described herein are intended only as illustrations of such devices and not as the specifications for such devices. ROHM CO.,LTD. disclaims any warranty that any use of such devices shall be free from infringement of any third party's intellectual property rights or other proprietary rights, and further, assumes no liability of whatsoever nature in the event of any such infringement, or arising from or connected with or related to the use of such devices.
- Upon the sale of any such devices, other than for buyer's right to use such devices itself, resell or otherwise dispose of the same, no express or implied right or license to practice or commercially exploit any intellectual property rights or other proprietary rights owned or controlled by
- ROHM CO., LTD. is granted to any such buyer.
- Products listed in this document are no antiradiation design.

The products listed in this document are designed to be used with ordinary electronic equipment or devices (such as audio visual equipment, office-automation equipment, communications devices, electrical appliances and electronic toys).

Should you intend to use these products with equipment or devices which require an extremely high level of reliability and the malfunction of which would directly endanger human life (such as medical instruments, transportation equipment, aerospace machinery, nuclear-reactor controllers, fuel controllers and other safety devices), please be sure to consult with our sales representative in advance.

#### About Export Control Order in Japan

Products described herein are the objects of controlled goods in Annex 1 (Item 16) of Export Trade Control Order in Japan.

In case of export from Japan, please confirm if it applies to "objective" criteria or an "informed" (by MITI clause) on the basis of "catch all controls for Non-Proliferation of Weapons of Mass Destruction.