

NON-ISOLATED DC/DC CONVERTERS

8.3 Vdc - 14 Vdc Input

0.75 Vdc - 5.0 Vdc/10 A Output

bel
POWER PRODUCTS

SRBC-10A2Ax

RoHS Compliant

Rev.A

- Non-Isolated
- High Efficiency
- High Power Density
- Excellent Thermal Performance
- Low Cost
- Flexible Output Voltage Sequencing
- Remote Sense
- Able to Sink/Source Current
- Under-voltage Lockout (UVLO)
- Over Temperature Protection
- OCP/SCP
- Wide Input
- Wide Trim
- Remote On/Off
- Active Low/High (option)
- Industrial Temperature Range



Description

The Bel SRBC-10A2Ax modules are a series of non-isolated dc/dc converters that deliver up to 10 A of output current with full load efficiency of 93% at 3.3 Vdc output. These modules provide precisely regulated voltage programmable via external resistor from 0.75 Vdc to 5.0 Vdc over a wide range of input voltage (8.3 Vdc - 14 Vdc). These modules have a sequencing feature that enables designers to implement various types of output voltage sequencing when powering multiple voltages on a board. The open-frame construction and small footprint enable designers to develop cost and space-efficient solutions. Standard features include remote On/Off, over current protection, short current protection, wide input, and programmable output voltage.

Part Selection

| Output Voltage | Input Voltage | Max. Output Current | Max. Output Power | Typical Efficiency | Model Number Active Low | Model Number Active High |
|----------------|---------------|---------------------|-------------------|--------------------|-------------------------|--------------------------|
| 0.75 V - 5.0 V | 8.3 V - 14 V | 10 A | 50.0 W | 95% | SRBC-10A2AL | SRBC-10A2A0 |

- Notes:** 1. Add "G" suffix at the end of the model number to indicate Tray Packaging.
2. All part numbers above indicate RoHS 6. Change the second letter "R" to "7" for RoHS 5 part numbers.

Absolute Maximum Ratings

| Parameter | Min | Typ | Max | Notes |
|---------------------------------|--------|-----|-----------------|-------|
| Input Voltage (continuous) | -0.3 V | - | 15 V | |
| Output Enable Terminal Voltage | -0.3 V | - | 15 V | |
| Sequencing Voltage ¹ | -0.3 V | - | V _{in} | |
| Ambient Temperature | -40 °C | - | 85 °C | |
| Storage Temperature | -55 °C | - | 125 °C | |

- Notes:** All specifications are typical at 25 °C unless otherwise stated.
1. SRBC-10A2Ax series of modules include a sequencing feature that enables users to implement various types of output voltage sequencing in their applications. This is accomplished via an additional sequencing pin. When the sequencing feature is not used, tie the SEQ pin to V_{in} or leave it unconnected.

NON-ISOLATED DC/DC CONVERTERS

8.3 Vdc - 14 Vdc Input

0.75 Vdc - 5.0 Vdc/10 A Output



Input Specifications

| Parameter | Min | Typ | Max | Notes |
|---|-------|-----------------------|-----------------------|---|
| Input Voltage | | | | |
| Vo, set ≤ 3.63 V | 8.3 V | 12 V | 14 V | |
| Vo, set > 3.63 V | 8.3 V | 12 V | 13.2 V | |
| Input Current (full load) | - | - | 6.5 A | An input line fuse must always be used. |
| Input Current (no load) | - | 50 mA | - | |
| Remote Off Input Current | - | 2 mA | - | |
| Input Reflected Ripple Current (pk-pk) | - | - | 400 mA | Tested with one 1000 uF/25 V AL input capacitor with ESR=0.03 ohm max and 4 × 47 uF/16 V tan capacitors with ESR=0.013 ohm max at 100 kHz, & simulated source impedance of 1000 nH, 5 Hz to 20 MHz. |
| Input Reflected Ripple Current (rms) | - | - | 150 mA | |
| I ² t Inrush Current Transient | - | 0.04 A ² s | 0.08 A ² s | |
| Turn-on Voltage Threshold | - | 8.2 V | | |
| Turn-off Voltage Threshold | - | 7.9 V | | |

Note: All specifications are typical at 25 °C unless otherwise stated.

Output Specifications

| Parameter | Min | Typ | Max | Notes | |
|--|-------------------|--------------------|--------------------|--|--|
| Output Voltage Set Point | -2% Vo,set | - | 2% Vo,set | Vin=12 V, full load | |
| Load Regulation | - | 0.1% Vo,set | - | | |
| Line Regulation | - | 0.1% Vo,set | - | | |
| Regulation Over Temperature (-40 °C to +85 °C) | - | 0.3% Vo,set | - | Tref=Tamin to Tamax | |
| Output Current | 0 A | - | 10 A | | |
| Current Limit Threshold | - | 200% Io | - | | |
| Short Circuit Surge Transient | - | 1 A ² s | 3 A ² s | | |
| Ripple and Noise (pk-pk) | - | 50 mV | 100 mV | Tested with 0-20 MHz, with 10 uF tantalum capacitor & 1 uF ceramic capacitor | |
| Ripple and Noise (rms) | - | 20 mV | 40 mV | | |
| Turn on Time | - | 6 mS | 10 mS | | |
| Overshoot at Turn on | - | - | 1% Vo,set | | |
| Output Capacitance | - | - | 5000 uF | | |
| Transient Response | | | | | |
| 50% ~ 100% Max Load | Vo = 0.75 V - 5 V | - | 100 mV | - | di/dt=2.5 A/uS; Vin=12 V; and with 2 × 150 uF polymer capacitors at the output |
| Settling Time | | - | 50 uS | - | |
| 100% ~ 50% Max Load | | - | 100 mV | - | |
| Settling Time | | - | 50 uS | - | |

Note: All specifications are typical at nominal input, full load at 25 °C unless otherwise stated.

NON-ISOLATED DC/DC CONVERTERS

8.3 Vdc - 14 Vdc Input

0.75 Vdc - 5.0 Vdc/10 A Output

bel
POWER PRODUCTS

General Specifications

| Parameter | Min | Typ | Max | Notes |
|--|----------------------|---------|---------|--|
| Efficiency | | | | Measured at Vin=12 V, full load |
| Vo=5.0 V | - | 95% | - | |
| Vo=3.3 V | - | 93% | - | |
| Vo=2.5 V | - | 92% | - | |
| Vo=1.8 V | - | 90% | - | |
| Vo=1.5 V | - | 89% | - | |
| Vo=1.2 V | - | 87.5% | - | |
| Vo=0.75 V | - | 81% | - | |
| Switching Frequency | 265 kHz | 300 kHz | 335 kHz | |
| Over Temperature Shutdown ¹ | - | 130 °C | - | |
| Output Voltage Trim Range | 0.7525 V | - | 5.0 V | |
| Remote Sense Compensation | - | - | 0.5 V | |
| MTBF | 4,982,651 hours | | | Calculated Per Bell Core SR-332 (Io = 80% load; Vo=5 V; Vin=12 V; Ta = 25°C) |
| Dimensions | | | | |
| Inches (L x W x H) | 1.3 x 0.53 x 0.315 | | | |
| Millimeters (L x W x H) | 33.02 x 13.46 x 8.00 | | | |
| Weight | - | 8 g | - | |

Notes: All specifications are typical at 25 °C unless otherwise stated.

1. The Tref temperature measurement location:

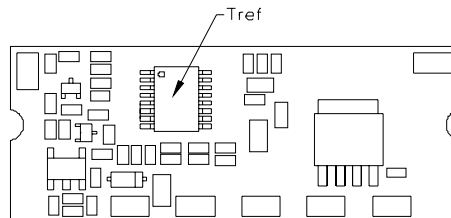

Control Specifications

| Parameter | Min | Typ | Max | Notes |
|---------------------------------|--------|--------|----------|--|
| Remote On/Off | | | | |
| Signal Low (Unit Off) | -0.2 V | - | 0.3 V | SRBC-10A2A0; Remote On/Off pin open, Unit on. |
| Signal High (Unit On) | - | - | Vin, max | |
| Signal Low (Unit On) | -0.2 V | - | 0.3 V | SRBC-10A2AL; Remote On/Off pin open, Unit on. |
| Signal High (Unit Off) | 2.5 V | - | Vin, max | |
| Voltage Sequencing | | | | |
| Sequencing Delay Time | 10 mS | - | - | Delay from Vin, min to application of voltage on SEQ pin |
| Sequencing Slew Rate Capability | - | - | 2 V/mS | Vinmin to Vinmax; Iomin to Iomax; Vseq<Vo |
| Tracking Accuracy | | | | |
| Power-Up | - | 100 mV | 200 mV | |
| Power-Down | - | 300 mV | 500 mV | |

NON-ISOLATED DC/DC CONVERTERS

8.3 Vdc - 14 Vdc Input

0.75 Vdc - 5.0 Vdc/10 A Output



Output Trim Equations

Equation for calculating the trim resistor (in Ω) given the desired adjusted voltage (V_{adj}) is shown below. The Trim Up resistor should be connected between the Trim pin and Ground.

$$R_{trimup} = \frac{10500}{V_{adj} - 0.7525} - 1000$$

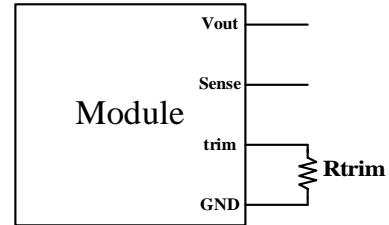

Equation for calculating the trim voltage (in V) given the desired adjusted voltage (V_{adj}) is shown below. The Trim Up voltage should be connected between the Trim pin and Ground.

$$V_{trimup} = 0.7 - 0.0667 \times (V_{adj} - 0.7525)$$

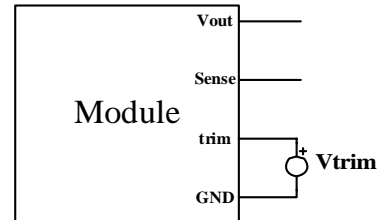

Thermal Derating Curves

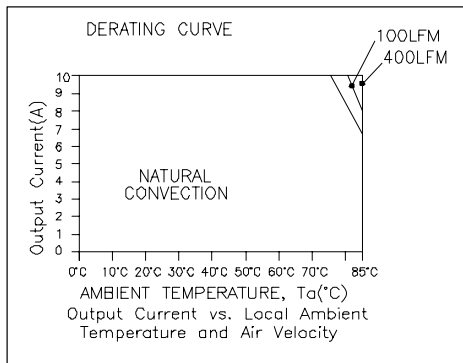

$V_o=0.75$ V

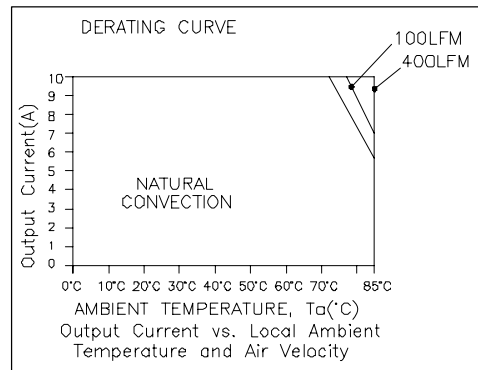

$V_o=1.8$ V

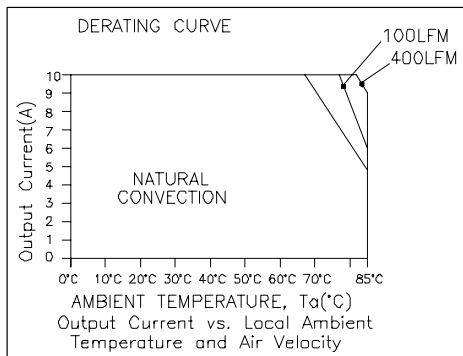

$V_o=3.3$ V

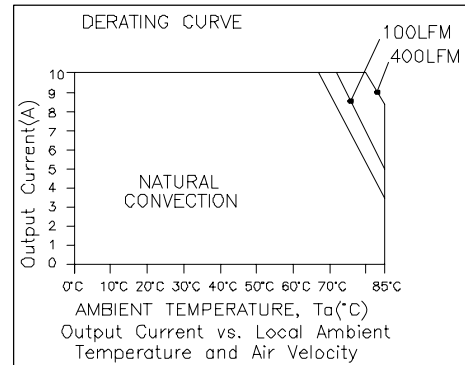

$V_o=5.0$ V

NON-ISOLATED DC/DC CONVERTERS

8.3 Vdc - 14 Vdc Input

0.75 Vdc - 5.0 Vdc/10 A Output



Efficiency Data

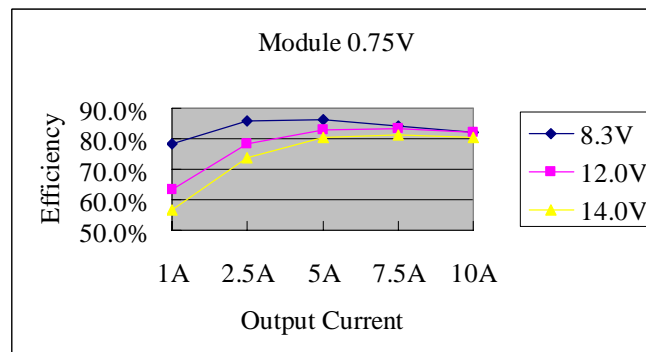
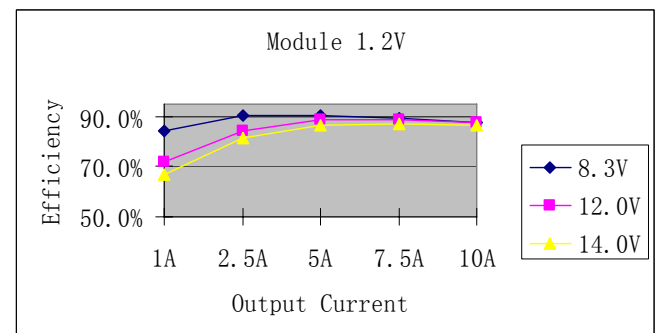
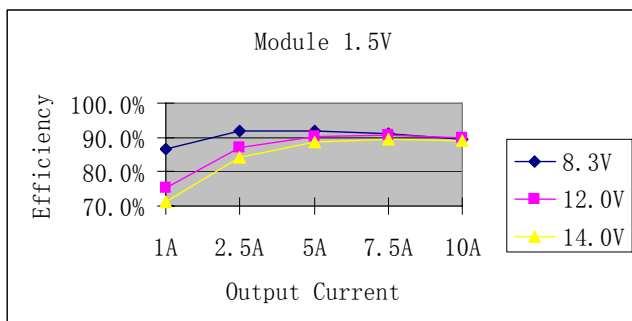
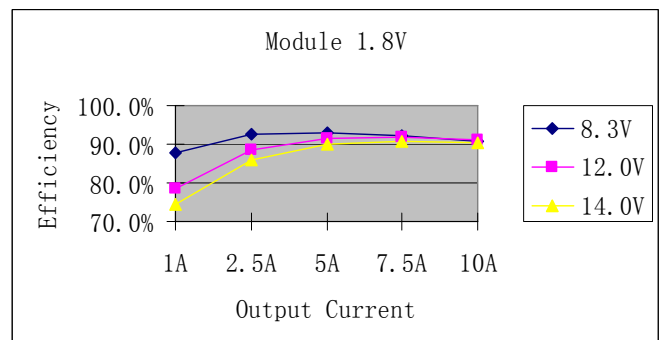
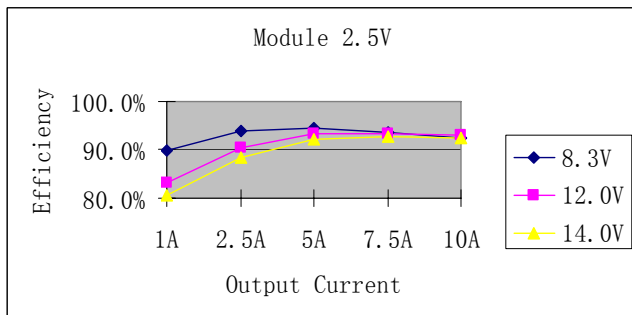
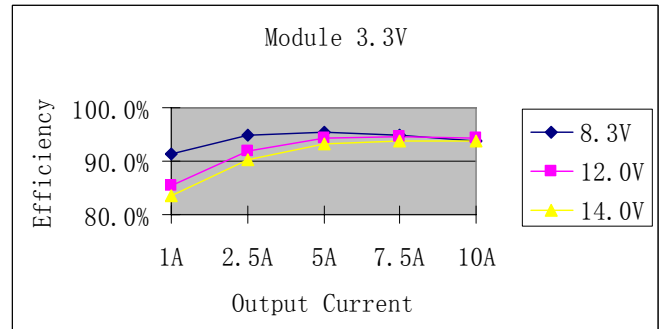
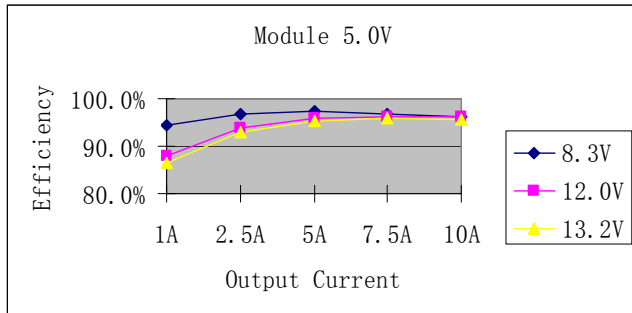

NON-ISOLATED DC/DC CONVERTERS

8.3 Vdc - 14 Vdc Input

0.75 Vdc - 5.0 Vdc/10 A Output



Ripple and Noise Waveforms

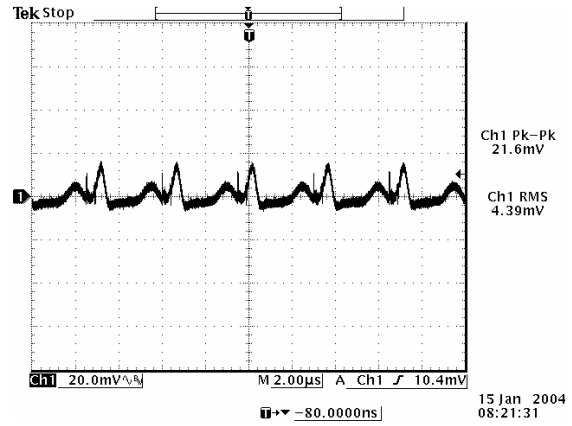
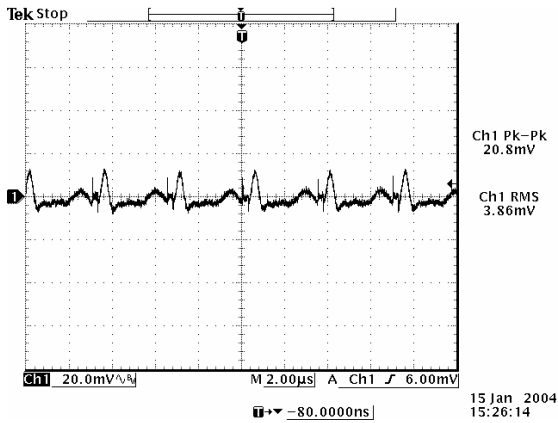

Ripple and noise at max load 0.75 Vdc output

Ripple and noise at max load 1.2 Vdc output

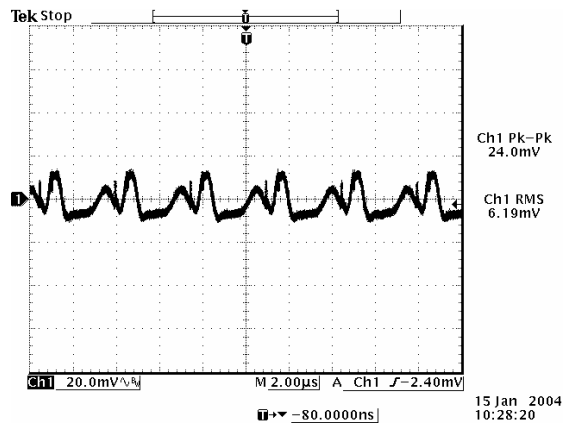
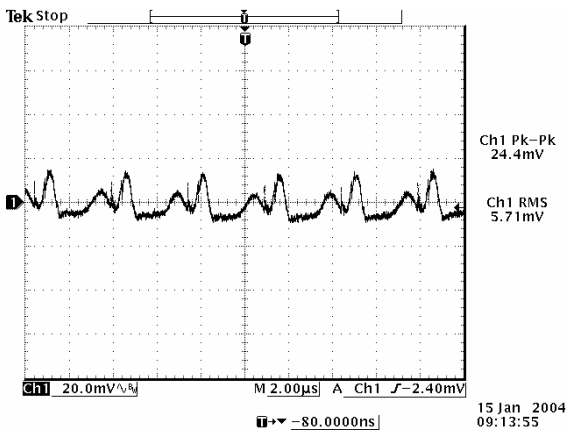

Ripple and noise at max load 1.5 Vdc output

Ripple and noise at max load 1.8 Vdc output

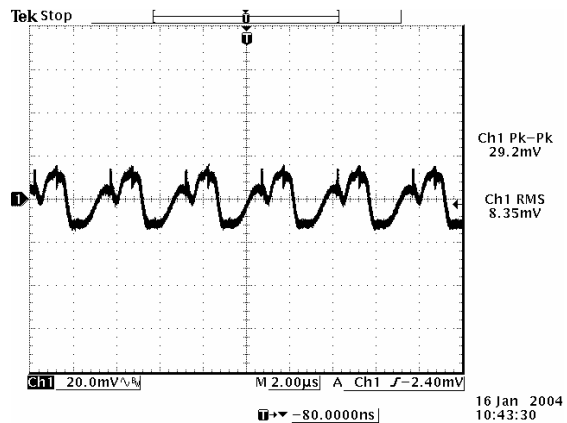
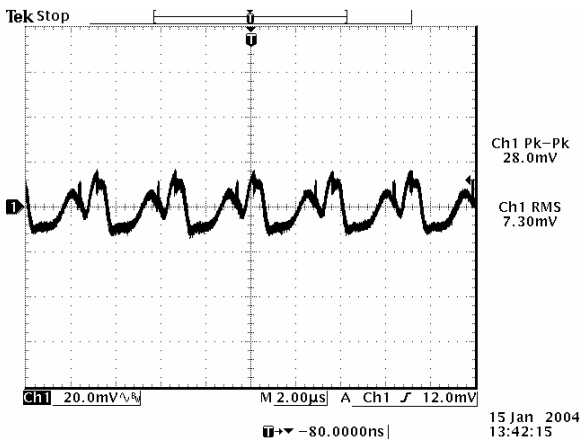

Ripple and noise at max load 2.5 Vdc output

Ripple and noise at max load 3.3 Vdc output

NON-ISOLATED DC/DC CONVERTERS

8.3 Vdc - 14 Vdc Input

0.75 Vdc - 5.0 Vdc/10 A Output



Ripple and Noise Waveforms (continued)

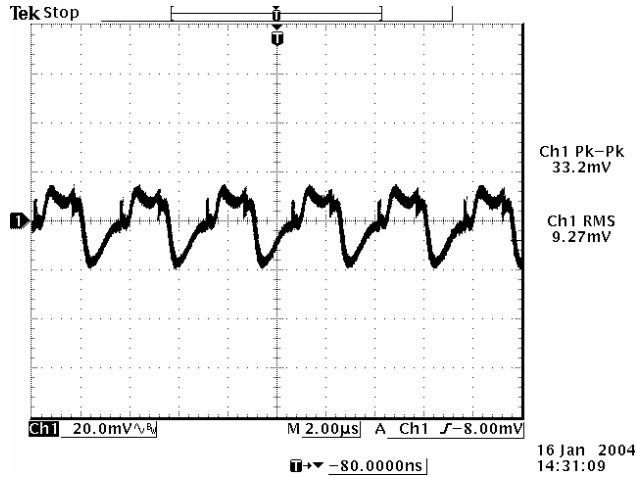

Ripple and noise at max load 5.0 Vdc output

Note: Ripple and Noise at 12 V input, with 10 µF tantalum capacitor and 1 µF ceramic capacitor at the output, and Ta=25 deg C.

Transient Response Waveforms

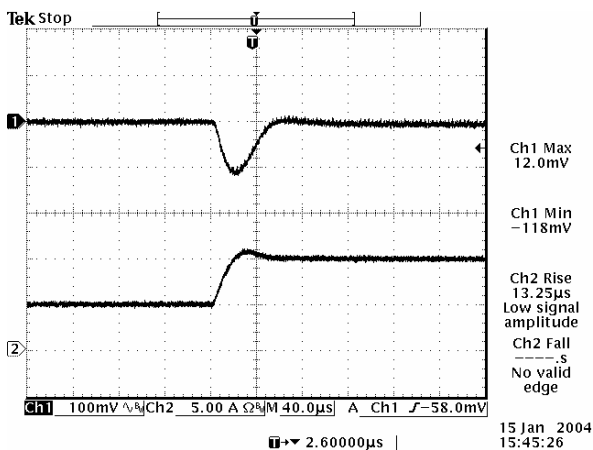

Transients 50% to 100% load 0.75 Vdc output

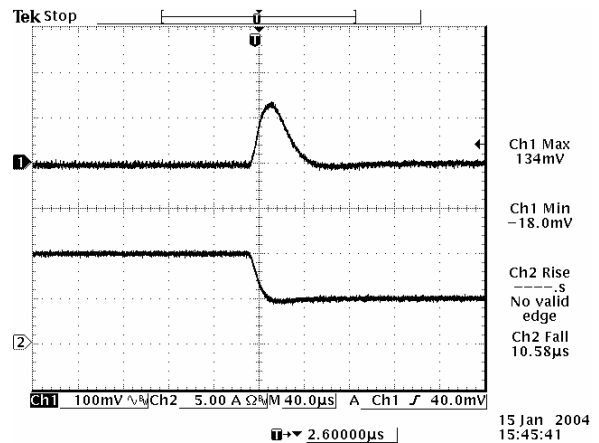

Transients 100% to 50% load 0.75 Vdc output

NON-ISOLATED DC/DC CONVERTERS

8.3 Vdc - 14 Vdc Input

0.75 Vdc - 5.0 Vdc/10 A Output



Transient Response Waveforms (continued)

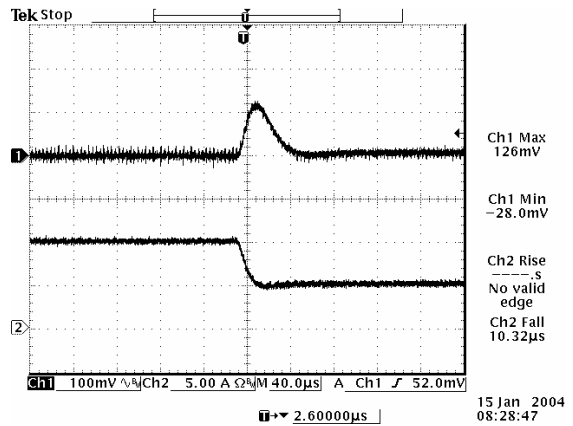
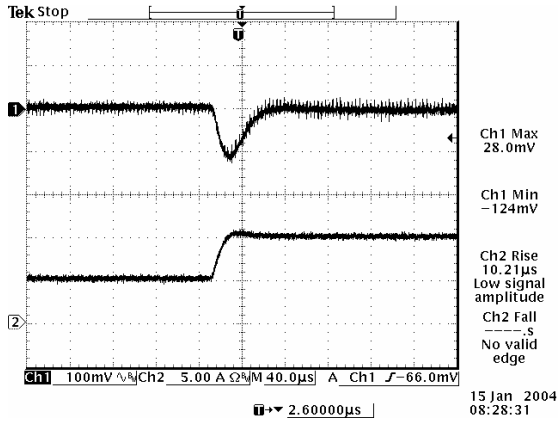

Transients 50% to 100% load 1.2 Vdc output

Transients 100% to 50% load 1.2 Vdc output

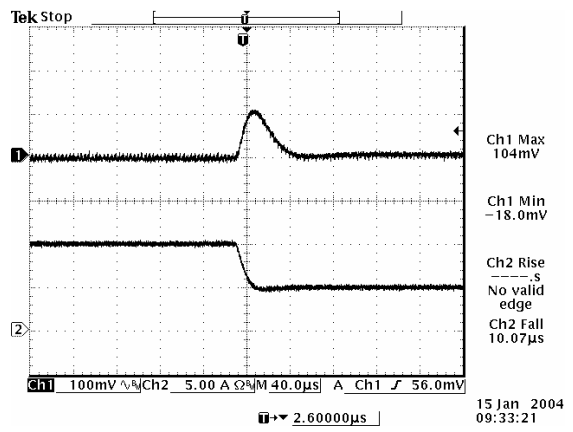
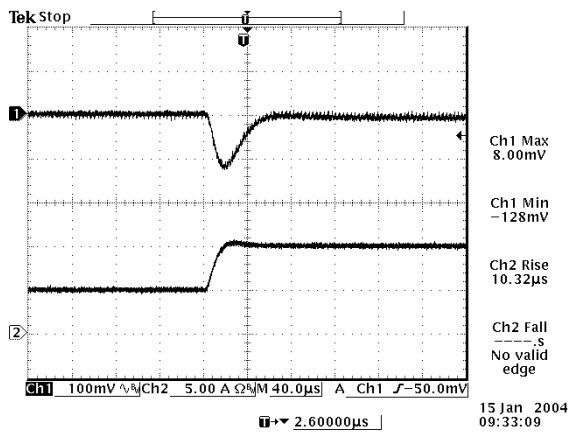

Transients 50% to 100% load 1.5 Vdc output

Transients 100% to 50% load 1.5 Vdc output

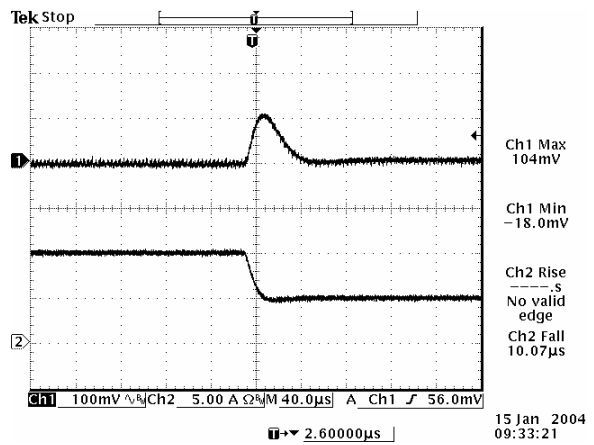
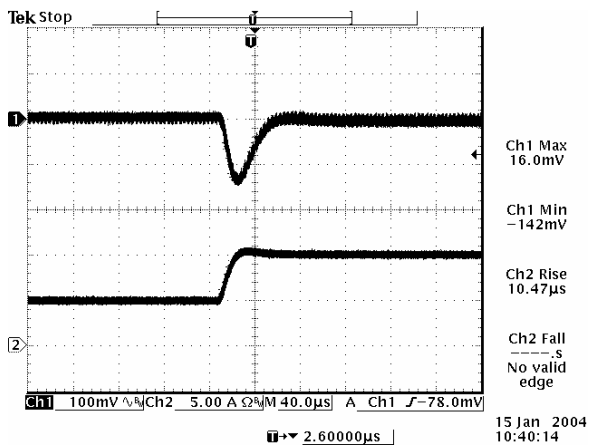

Transients 50% to 100% load 1.8 Vdc output

Transients 100% to 50% load 1.8 Vdc output

NON-ISOLATED DC/DC CONVERTERS

8.3 Vdc - 14 Vdc Input

0.75 Vdc - 5.0 Vdc/10 A Output



Transient Response Waveforms (continued)

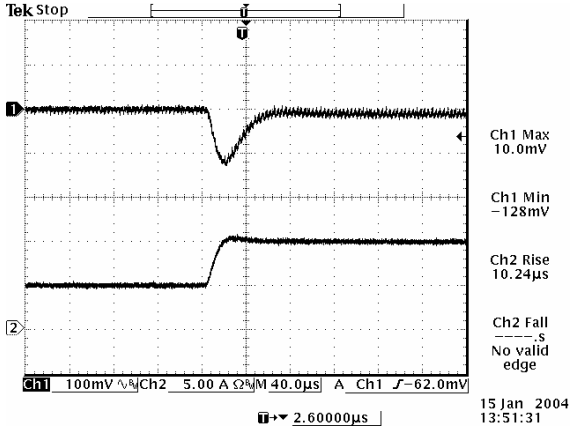

Transients 50% to 100% load 1.5 Vdc output

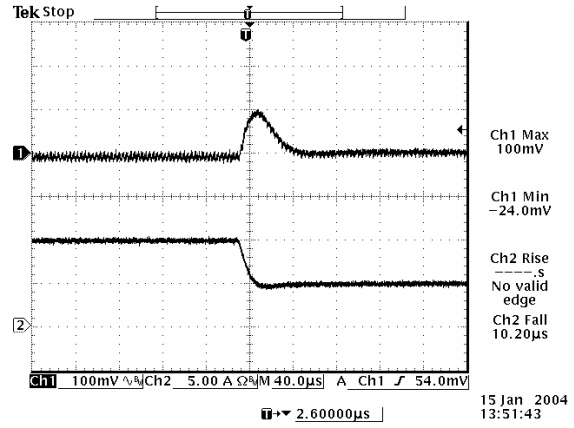

Transients 100% to 50% load 2.5 Vdc output

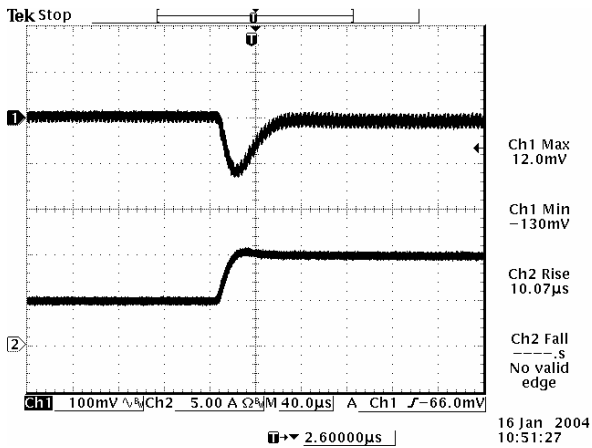

Transients 50% to 100% load 3.3 Vdc output

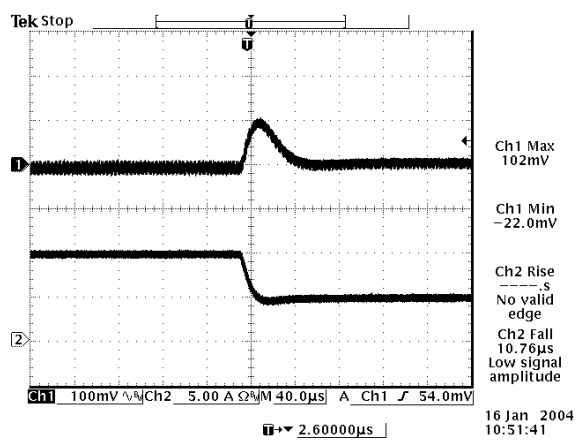

Transients 100% to 50% load 3.3 Vdc output

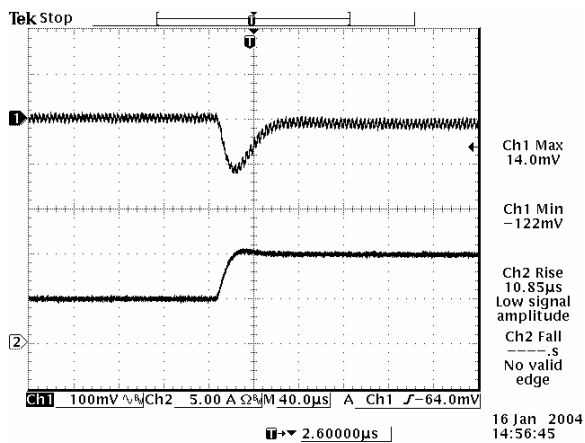

Transients 50% to 100% load 5.0 Vdc output

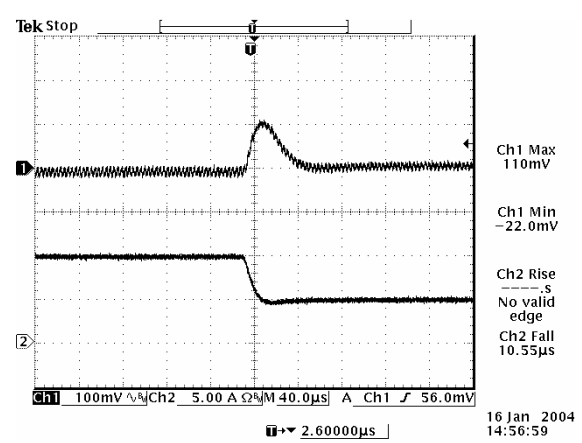

Transients 100% to 50% load 5.0 Vdc output

Note: Transient response at 12 V input, $di/dt=2.5 A/\mu S$, with external 2 x 150 μF polymer capacitor at the output, $T_a=25$ deg C.

NON-ISOLATED DC/DC CONVERTERS

8.3 Vdc - 14 Vdc Input

0.75 Vdc - 5.0 Vdc/10 A Output



Mechanical Outline

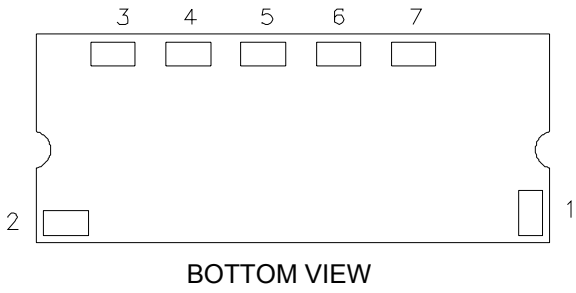
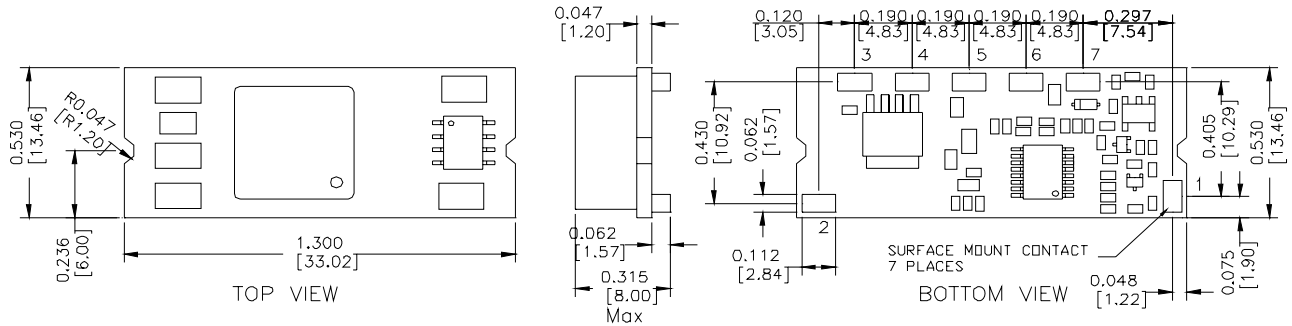

Pin Connections

| Pin | Function |
|-----|---------------|
| 1 | Remote On/Off |
| 2 | Vin+ |
| 3 | SEQ |
| 4 | Ground |
| 5 | Vout+ |
| 6 | Trim |
| 7 | Remote Sense |

RECOMMENDED PAD LAYOUT

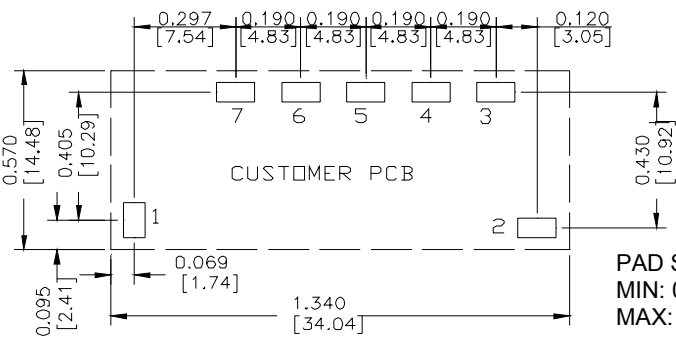

PAD SIZE:
 MIN: 0.14" * 0.095" (3.56mm * 2.41mm)
 MAX: 0.165" * 0.11" (4.19mm * 2.79mm)

RoHS Compliance

Complies with the European Directive 2002/95/EC, calling for the elimination of lead and other hazardous substances from electronic products.



©2007 Bel Fuse Inc. Specifications subject to change without notice. 011607

CORPORATE
 Bel Fuse Inc.
 206 Van Vorst Street
 Jersey City, NJ 07302
 Tel 201-432-0463
 Fax 201-432-9542
www.belfuse.com

FAR EAST
 Bel Fuse Ltd.
 8F/ 8 Luk Hop Street
 San Po Kong
 Kowloon, Hong Kong
 Tel 852-2328-5515
 Fax 852-2352-3706
www.belfuse.com

EUROPE
 Bel Fuse Europe Ltd.
 Preston Technology Management Centre
 Marsh Lane, Suite G7, Preston
 Lancashire, PR1 8UD, U.K.
 Tel 44-1772-556601
 Fax 44-1772-888366
www.belfuse.com