

## ISOLATED DC/DC CONVERTERS

48 Vdc Input      3.3 Vdc/50 A, 5.0 Vdc/30 A Output

**bel**  
POWER PRODUCTS

0RHB-C5T Series

RoHS Compliant

Rev.A

- Isolated
- High Efficiency
- High Power Density
- Low Cost
- Fixed Frequency (330 kHz)
- Input Under/Over Voltage Lockout
- UL60950-1 Recognized (UL/cUL)
- Output Over Voltage Shutdown
- OCP/SCP
- Over Temperature Protection
- Remote On/Off
- Output Voltage Trim
- Positive/Negative Remote Sense



### Description

The 0RHB-C5T Series are isolated dc/dc converters that operate from a nominal 48 Vdc source. This unit will provide up to 165 W of output power from a nominal 48 Vdc input. This unit is designed to be highly efficient and low cost. It is provided in an industry standard half-brick package.

### Part Selection

Output Voltage	Input Voltage	Max. Output Current	Max. Output Power	Typical Efficiency	Model Number Active High	Model Number Active Low
5.0 V	48 V	30 A	150 W	93.0%	0RHB-C5T050	0RHB-C5T05L
3.3 V	48 V	50 A	165 W	92.5%	0RHB-C5T033	0RHB-C5T03L

- Notes:** 1. Add "G" suffix at the end of the model number to indicate Tray Packaging.  
2. All part numbers above indicate RoHS 6. Change the second letter "R" to "7" for RoHS 5 part numbers.

### Absolute Maximum Ratings

Parameter	Min	Typ	Max	Notes
Input Voltage (continuous)	-0.3 V	-	80 V	
Remote On/Off	-0.3 V	-	18 V	
I/O Isolation Voltage	-	-	2000 V	
Ambient Temperature	-40 °C	-	85 °C	
Storage Temperature	-55 °C	-	125 °C	

### Input Specifications

Parameter	Min	Typ	Max	Notes
Input Voltage	36V	48 V	75 V	
Input Current (full load)				
Vo=5.0 V	-	-	5.0 A	
Vo=3.3 V	-	-	5.2 A	
Input Current (no load)	-	120 mA	180 mA	
Remote Off Input Current		5 mA	20 mA	
Input Reflected Ripple Current (pk-pk)	-	20 mA	40 mA	Tested with simulated source impedance of 10 uH, 5 Hz to 20 MHz; use a 100 uF /100 V electrolytic capacitor with ESR = 1 ohm max. at 200 kHz at 25 °C.
Input Reflected Ripple Current (rms)	-	5 mA	10 mA	
I <sup>2</sup> t Inrush Current Transient	-	0.05 A <sup>2</sup> s	0.1 A <sup>2</sup> s	
Turn-on Voltage Threshold	31 V	-	35 V	
Turn-off Voltage Threshold	29 V	-	33 V	
Input Over Voltage Threshold	76 V	-	80 V	

**Note:** All specifications are typical at 25 °C unless otherwise stated.

# ISOLATED DC/DC CONVERTERS

48 Vdc Input      3.3 Vdc/50 A, 5.0 Vdc/30 A Output



## Output Specifications

Parameter		Min	Typ	Max	Notes		
Output Voltage Set Point	Vo=5.0 V	4.925 V	5.000 V	5.075 V	Vin=48 V, Io=50% load		
	Vo=3.3 V	3.250 V	3.300 V	3.350 V			
Line Regulation	Vo=5.0 V	-	±5 mV	±10 mV			
	Vo=3.3 V	-	±3 mV	±7 mV			
Load Regulation	Vo=5.0 V	-	±10 mV	±20 mV			
	Vo=3.3 V	-	±7 mV	±15 mV			
Regulation Over Temperature (-40 °C to +85 °C)	Vo=5.0 V	-	±45 mV	±75 mV			
	Vo=3.3 V	-	±30 mV	±50 mV			
Output Current	Vo=5.0 V	0 A	-	30 A			
	Vo=3.3 V	0 A	-	50 A			
Current Limit Threshold	Vo=5.0 V	32 A	38 A	45 A			
	Vo=3.3 V	55 A	65 A	75 A			
Short Circuit Surge Transient		-	3 A <sup>2</sup> s	5 A <sup>2</sup> s			
Ripple and Noise (rms)	Vo=5.0 V	-	25 mV	50 mV	Test conditions: 0-20MHz BW, with a 1uF ceramic capacitor and a 10uF Tantalum capacitor at the output.		
	Vo=3.3 V	-	15 mV	30 mV			
Ripple and Noise (pk-pk)	Vo=5.0 V	-	70 mV	140 mV			
	Vo=3.3 V	-	55 mV	100 mV			
Turn on Time		-	15 mS	20 mS			
Overshoot at Turn on		-	0%	5%			
Output Capacitance	Vo=5.0 V	0 uF	-	10000 uF			
	Vo=3.3 V	0 uF	-	20000 uF			
<b>Transient Response</b>							
75% ~ 50% Max Load	Overshoot	Vo=5.0 V	-	250 mV	400 mV	Test conditions: di/dt = 0.1 A/uS, Vin=48 V with a 1 uF ceramic capacitor and a 10 uF Tantalum capacitor at the output.	
	Settling Time		-	250 uS	400 uS		
50% ~ 75% Max Load	Overshoot		-	250 mV	400 mV		
	Settling Time		-	250 uS	400 uS		
75% ~ 50% Max Load	Overshoot		Vo=3.3 V	-	100 mV		200 mV
	Settling Time			-	200 uS		300 uS
50% ~ 75% Max Load	Overshoot	-		100 mV	200 mV		
	Settling Time	-		200 uS	300 uS		

**Note:** All specifications are typical at nominal input, full load at 25 °C unless noted.

# ISOLATED DC/DC CONVERTERS

48 Vdc Input      3.3 Vdc/50 A, 5.0 Vdc/30 A Output



## General Specifications

Parameter	Min	Typ	Max	Notes
Efficiency Vo=5.0 V Vo=3.3 V	90% 90%	93.0% 92.5%	- -	Vin=48V, full load , Ta=25°C
Switching Frequency	300 kHz	330 kHz	360 kHz	
Isolation capacitance	-	1500 pF	-	
Output Voltage Trim Range	80% Vo	-	110% Vo	
Over Temperature Protection	-	120 °C	-	
Over Voltage Protection <sup>1</sup>	-	130% Vo	-	
Input to Output Isolation Voltage <sup>2</sup>	-	-	2000 V	
MTBF	TBD			Calculated Per Bell Core SR-332 (Io = Nominal; Ta = 25 °C)
Dimensions Inches millimeters	2.28 x 2.4 x 0.42 57.51 x 60.98 x 10.67			
Weight	-	76 g	-	

**Notes:** All specifications are typical at 25 °C unless otherwise stated.

- OVP is tested under 48 Vin and full load with photo coupler short. The output will be latched off if the output voltage exceeds over voltage specification. To turn the converter on requires either cycling the ON/OFF pin or power to the converter.
- Isolation between input and output is basic isolation, test duration is 60 seconds.

## Control Specifications

Parameter	Min	Typ	Max	Notes	
<b>Remote On/Off</b>					
Signal Low (Unit On)	Active Low	-0.3 V	-	0.8 V	The remote on/off pin open, Unit off.
Signal High (Unit Off)		2.4 V	-		
Signal Low (Unit Off)	Active High	-0.3 V	-	0.8 V	The remote on/off pin open, Unit on.
Signal High (Unit On)		2.4 V	-		

## Output Trim Equations

Equations for calculating the trim resistor (in kΩ) are shown below. The Trim Down resistor should be connected between the Trim pin and Ground pin. The Trim Up resistor should be connected between the Trim pin and the Vout. Only one of the resistors should be used for any given application.

$$R_{trimdown} = \frac{100}{|\delta|} - 2 [k\Omega]$$

$$R_{trimup} = \frac{(100 + \delta) \cdot V_o - 122.5}{1.225 \cdot \delta} - 2 [k\Omega]$$

**Notes:**

$$\delta = \frac{(V_o_{req} - V_o)}{V_o} \times 100 [\%]$$

V<sub>o\_req</sub>=Desired(trimmed) output voltage[V]

Output voltage V<sub>o</sub>=3.304 V for 3.3 V; V<sub>o</sub>=5.008 V for 5 V.

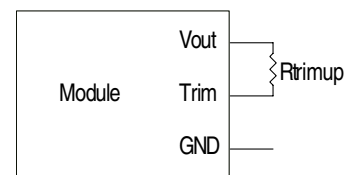
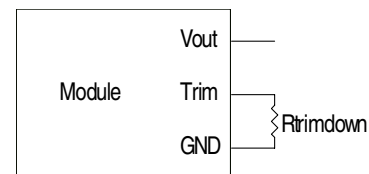

# ISOLATED DC/DC CONVERTERS

48 Vdc Input    3.3 Vdc/50 A, 5.0 Vdc/30 A Output



## Efficiency Data

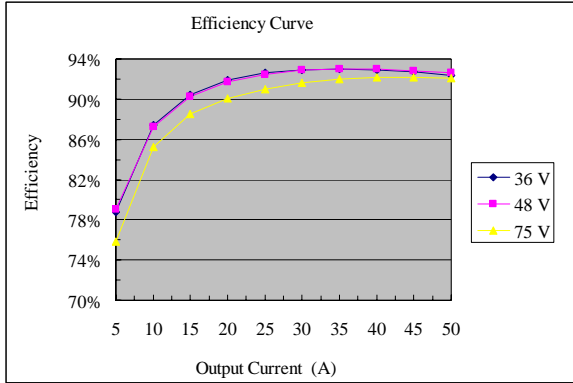

ORHB-C5T03x

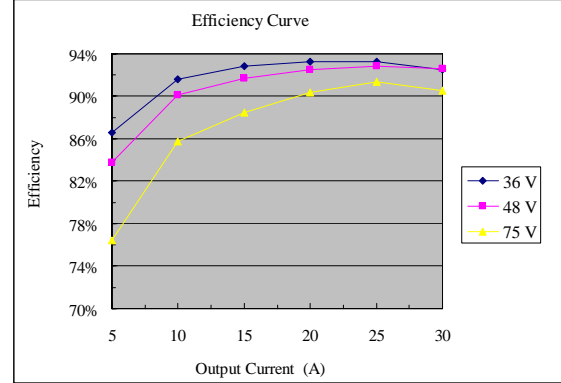

ORHB-C5T05x

## Thermal Derating Curves

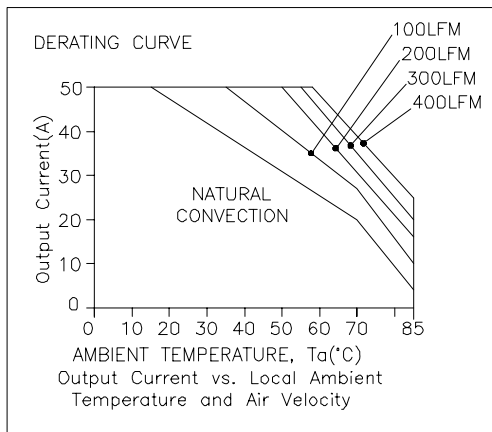

ORHB-C5T03x

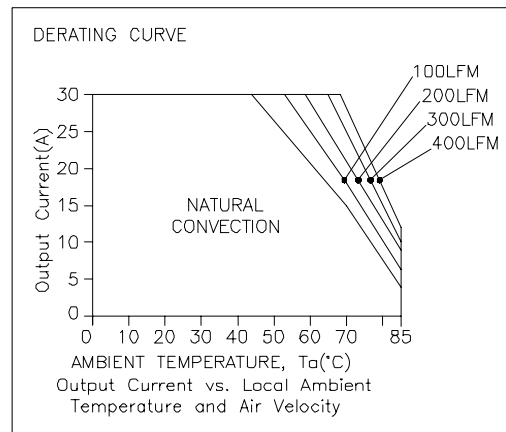

ORHB-C5T05x

FORCED AIRFLOW DIRECTION

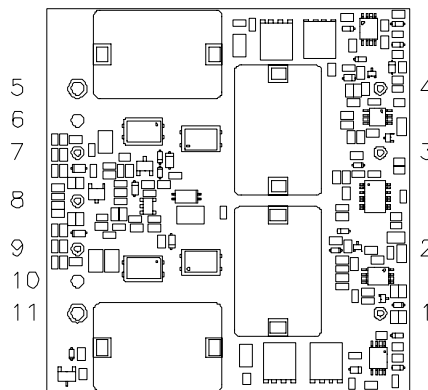

# ISOLATED DC/DC CONVERTERS

48 Vdc Input

3.3 Vdc/50 A, 5.0 Vdc/30 A Output



## Ripple and Noise Waveforms

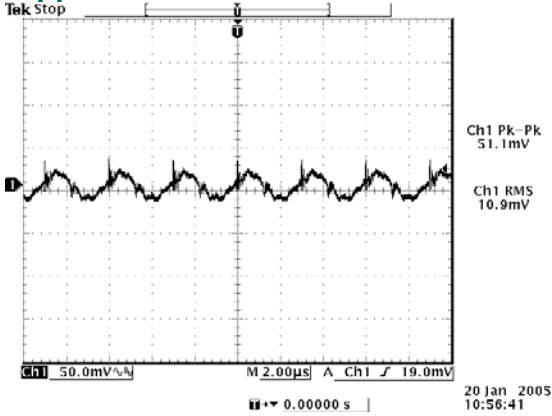

Ripple and noise at full load 3.3 V/50 A output

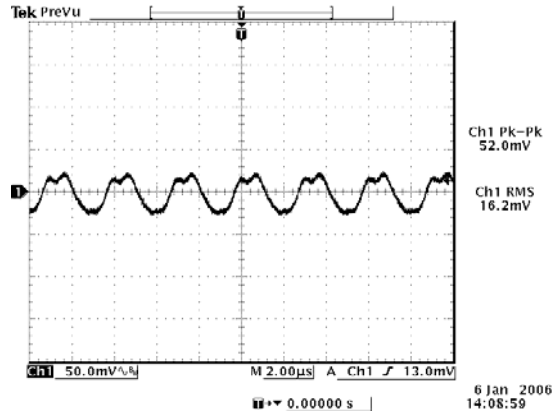

Ripple and noise at full load 5.0 V/30 A output

**Note:** Ripple and noise at 48 V input, with a 1  $\mu$ F ceramic capacitor and a 10  $\mu$ F tantalum capacitor at the output and  $T_a=25$  deg C.

## Transient Response Waveforms

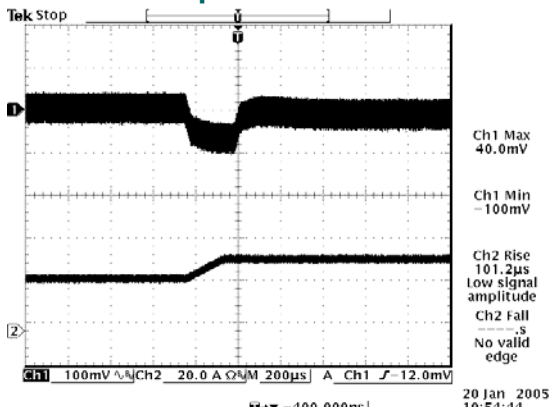

Vout=3.3 V, 50% to 75% Load Transients

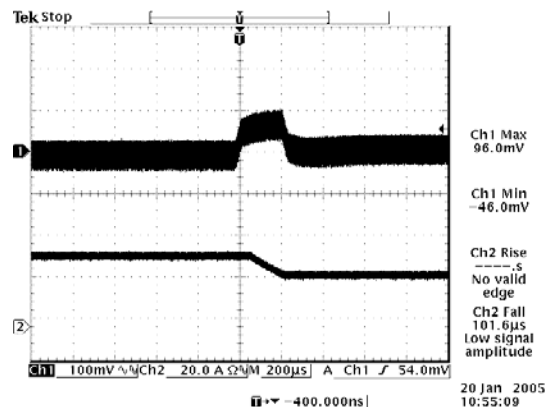

Vout=3.3 V, 75% to 50% Load Transients

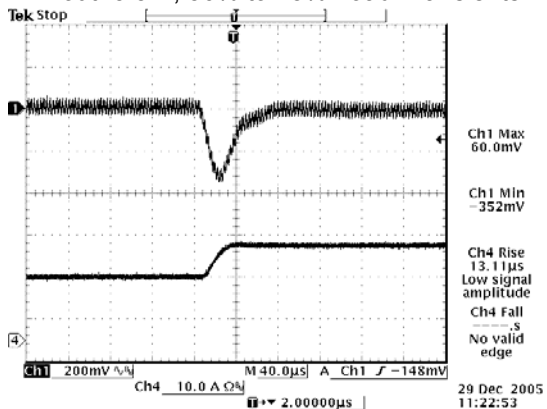

Vout=5.0 V, 50% to 75% Load Transients

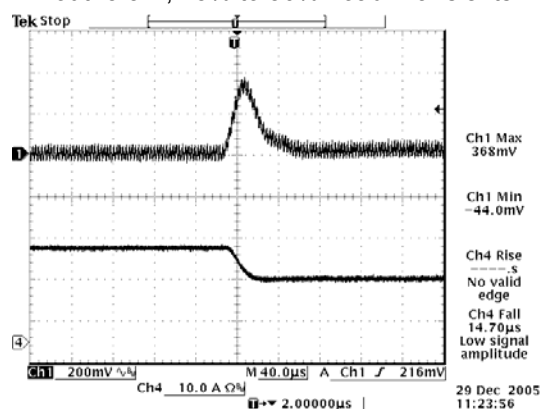

Vout=5.0 V, 75% to 50% Load Transients

**Note:** Transient Response is tested at  $di/dt=0.1$  A/ $\mu$ s ( $V_o=3.3$  V),  $di/dt=0.5$  A/ $\mu$ s ( $V_o=5.0$  V),  $V_{in}=48$  V,  $T_a=25^\circ$  C, with a 1  $\mu$ F ceramic capacitor and a 10  $\mu$ F tantalum capacitor at the output.

# ISOLATED DC/DC CONVERTERS

48 Vdc Input      3.3 Vdc/50 A, 5.0 Vdc/30 A Output



## Mechanical Outline

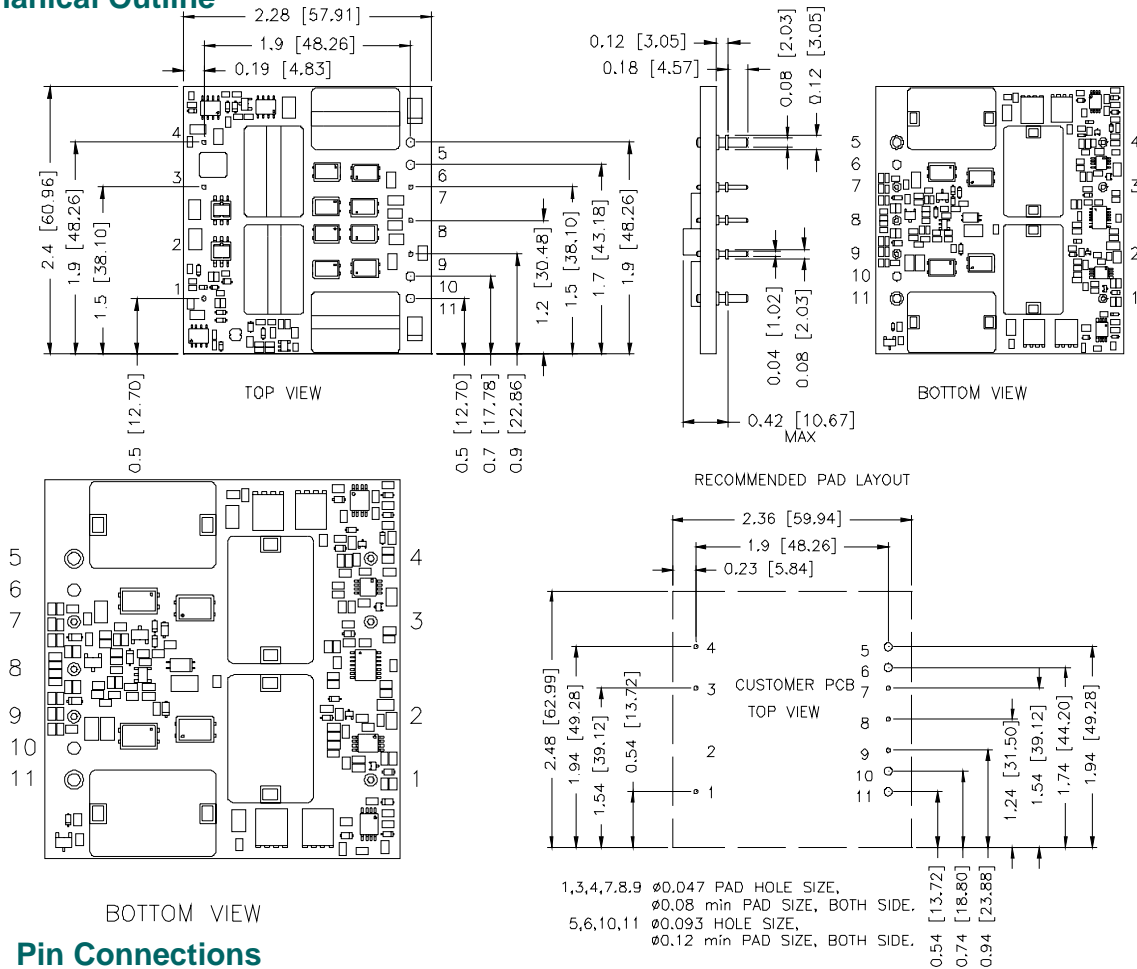

## Pin Connections

pin#	function	pin size	pin#	function	pin size
1	-Input	0.04"	6	N/A	
2	N/A		7	+Sense	0.04"
3	On/Off	0.04"	8	Trim	0.04"
4	+Input	0.04"	9	-Sense	0.04"
5	+Output	0.08"	10	N/A	
			11	-Output	0.08"

## RoHS Compliance

Complies with the European Directive 2002/95/EC, calling for the elimination of lead and other hazardous substances from electronic products.



©2007 Bel Fuse Inc. Specifications subject to change without notice. 030307

### CORPORATE

Bel Fuse Inc.  
206 Van Vorst Street  
Jersey City, NJ 07302  
Tel 201-432-0463  
Fax 201-432-9542  
[www.belfuse.com](http://www.belfuse.com)

### FAR EAST

Bel Fuse Ltd.  
8F/ 8 Luk Hop Street  
San Po Kong  
Kowloon, Hong Kong  
Tel 852-2328-5515  
Fax 852-2352-3706  
[www.belfuse.com](http://www.belfuse.com)

### EUROPE

Bel Fuse Europe Ltd.  
Preston Technology Management Centre  
Marsh Lane, Suite G7, Preston  
Lancashire, PR1 8UD, U.K.  
Tel 44-1772-556601  
Fax 44-1772-888366  
[www.belfuse.com](http://www.belfuse.com)