

## ISOLATED DC/DC CONVERTERS

24 Vdc Input 15 Vdc /6.67 A Output

**bel**  
POWER PRODUCTS

**0RHB-C0Q15x RoHS Compliant Rev.E**

- Isolated
- Fixed Frequency
- High Efficiency
- Output Voltage Trim
- Input Under Voltage Lockout
- Input Reverse Voltage Protection
- Basic Insulation
- Output Over Voltage Clamp
- Over Temperature Protection
- SCP/OCP
- Low Cost
- Remote On/Off
- Excellent Thermal Performance
- Heatsink for Extended Operation



### Description

The 0RHB-C0Q15x is an isolated dc/dc converter that operates from a nominal 24 Vdc source. This unit provides up to 100 W of output power from a nominal 24 Vdc input. This unit is designed to be highly efficient and low cost. The converter is provided in an industry standard half brick package.

### Part Selection

Output Voltage	Input Voltage	Max. Output Current	Max. Output Power	Typical Efficiency	Model Number Active High	Model Number Active Low
15 Vdc	24 Vdc	6.67 A	100 W	86%	0RHB-C0Q150	0RHB-C0Q15L

- Notes:** 1. Add "G" suffix at the end of the model number to indicate "Tray Packaging".  
2. All part numbers above indicate RoHS 6. Change the second letter "R" to "7" for RoHS 5 part numbers.

### Absolute Maximum Ratings

Parameter	Min	Typ	Max	Notes
Input Voltage (continuous)	-0.3 V	-	36 V	
Remote On/Off	-0.3 V	-	18 V	
I/O Isolation Voltage	-	-	1500 V	
Ambient Temperature	-40 °C	-	85 °C	
Storage Temperature	-55 °C	-	125 °C	

**Note:** All specifications are typical at 25 °C unless otherwise stated.

### Input Specifications

Parameter	Min	Typ	Max	Notes
Input Voltage	9 V	24 V	36 V	
Input Current (no load)	-	40 mA	60 mA	
Input Current (full load)	-	-	14 A	
Remote Off Input Current	-	2 mA	5 mA	
Input Reflected Ripple Current (pk-pk)	-	30 mA	50 mA	With simulated source impedance of 12 uH, 5 Hz to 20 MHz; use a 100uF/100 V electrolytic capacitor with ESR = 1 ohm max at 200 kHz.
Input Reflected Ripple Current (rms)	-	10 mA	18 mA	
I <sup>2</sup> t Inrush Current Transient	-	0.5 A <sup>2</sup> s	-	
Turn-on Voltage Threshold	8 V	8.5 V	9 V	
Under Voltage Threshold	7 V	8 V	9 V	

**Note:** All specifications are typical at nominal input, full load at 25 °C unless otherwise stated

# ISOLATED DC/DC CONVERTERS

24 Vdc Input 15 Vdc /6.67 A Output



## Output Specifications

Parameter	Min	Typ	Max	Notes		
Output Voltage Set Point	14.7 V	15.0 V	15.3 V	V <sub>in</sub> =24 V, I <sub>o</sub> =80%Load		
Line Regulation	-	0.01%V <sub>o</sub>	0.1%V <sub>o</sub>			
Load Regulation	-	0.02%V <sub>o</sub>	0.2%V <sub>o</sub>			
Regulation Over Temperature (-40 °C to 85 °C)	-	0.003%V <sub>o</sub> /C	0.005%V <sub>o</sub> /C			
Output Current <sup>1</sup>	0.667 A	-	6.67 A			
Current Limit Threshold (V <sub>o</sub> = 90% V <sub>o, nom</sub> )	7 A	12 A	15 A			
Ripple and Noise (rms)	-	60 mV	-	0-20MHz BW, with a 1µF ceramic capacitor and a 10uF Tantalum capacitor at output.		
Ripple and Noise (pk-pk)	-	150 mV	-			
Turn on Time	10 mS	20 mS	40 mS			
Rise Time	-	5 mS	-			
Overshoot at Turn on	-	0%	3%			
Output Capacitance	0 uF	-	1000 uF			
<b>Transient Response</b>						
50% ~ 75% Max Load	Overshoot	V <sub>o</sub> =15 V	-	500 mV	800 mV	di/dt=0.1 A/us, V <sub>in</sub> =24 Vdc, T <sub>a</sub> =25 °C, and 1 uF ceramic capacitor and a 10 uF Aluminum capacitor at output.
	Settling Time		-	200 uS	300 uS	
75% ~ 50% Max Load	Overshoot		-	500 mV	800 mV	
	Settling Time		-	200 uS	300 uS	

**Notes:** 1. No damage to the module will occur when the output is operated at less than minimum load. However the output voltage may contain a low frequency component that may exceed output noise specifications.  
2. All specifications are typical at nominal input, full load at 25 °C unless otherwise stated.

## General Specifications

Parameter	Min	Typ	Max	Notes
Efficiency	83%	86%	-	V <sub>in</sub> =24 V, full load
Switching Frequency	-	325 kHz	-	
Isolation Capacitance	-	3900 pF	-	
Output Voltage Trim Range	7.5 V	-	16.5 V	The voltage regulated by trim and remote sense should be between 7.5 V to 16.5 V.
Remote Sense	-	-	10%	
Over Temperature Protection	-	120 °C	-	
Over Voltage Protection	115 %	-	135 %	V <sub>in</sub> =24 V, I <sub>o</sub> =full load
MTBF	2,254,824 hours			Calculated Per Bell Core SR-332 (V <sub>in</sub> =24 V, V <sub>o</sub> =15 V, I <sub>o</sub> =80%, T <sub>a</sub> = 25 °C)
Dimensions Inches (L × W × H) Millimeters (L × W × H)	2.4 x 2.28 x 0.55 60.96 x 57.91 x 13.96			
Weight	-	83 g	-	

**Note:** All specifications are typical at 25 °C unless otherwise stated.

# ISOLATED DC/DC CONVERTERS

24 Vdc Input 15 Vdc /6.67 A Output



## Control Specifications

Parameter	Min	Typ	Max	Notes
<b>Remote On/Off</b>				
Signal Low (Unit On)	-0.3 V	-	1 V	The remote on/off pin open, Unit Off.
Signal High (Unit Off)				
Signal Low (Unit Off)	3 V	-	18 V	The remote on/off pin open, Unit On.
Signal High (Unit On)				
Current Source/Sink	0 mA	-	0.5 mA	

## Output Trim Equations

1. Output Voltage Adjustment by applying external voltage. The  $V_{trim}$  must add at Trim and Sense(-), the output voltage measure must between at Sense(+) and Sense(-).

Trim test circuit

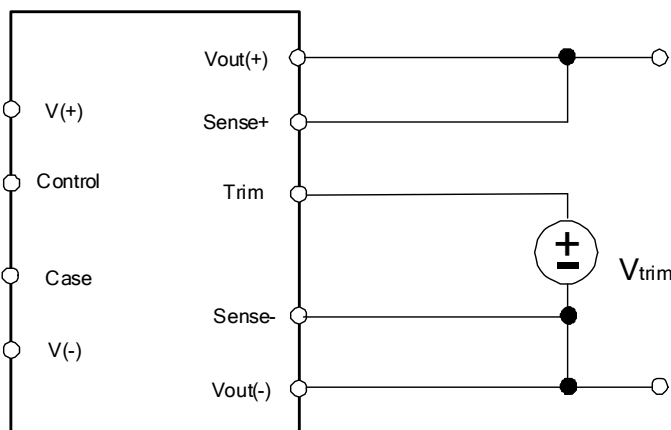

Trim curve

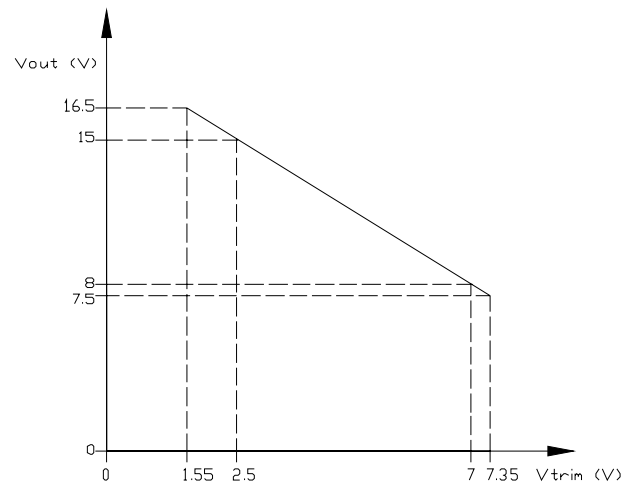

## 2. Output Voltage Adjustment by applying external resistor

The Trim down resistor should be connected between the Trim pin and Sense(+) pin. The Trim up resistor should be connected between the Trim pin and the Sense(-). Only one of the resistors should be used for any given application. The output voltage measure must between at Sense(+) and Sense(-).

# ISOLATED DC/DC CONVERTERS

24 Vdc Input 15 Vdc /6.67 A Output



## Output Trim Equations (continued)

### Trim down test circuit

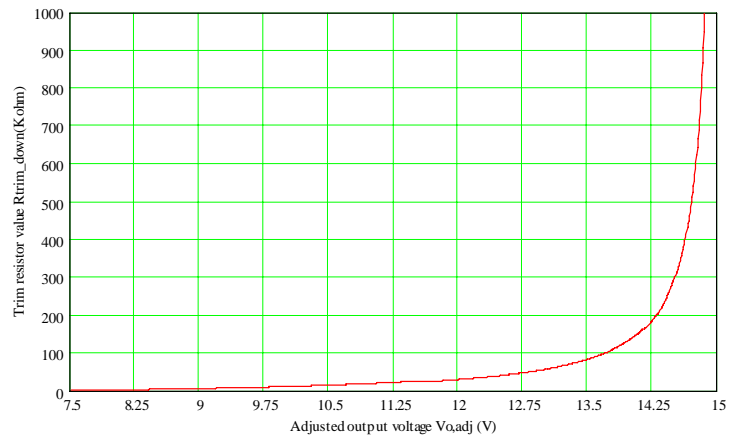
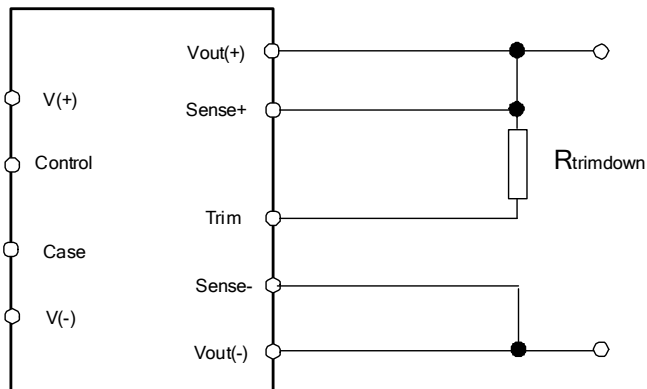

$$R_{trimdown} = \frac{12.7 \cdot (V_{o\_req} - 2.5)}{V_o - V_{o\_req}} - 8.2 [k\Omega]$$

### Trim up test circuit

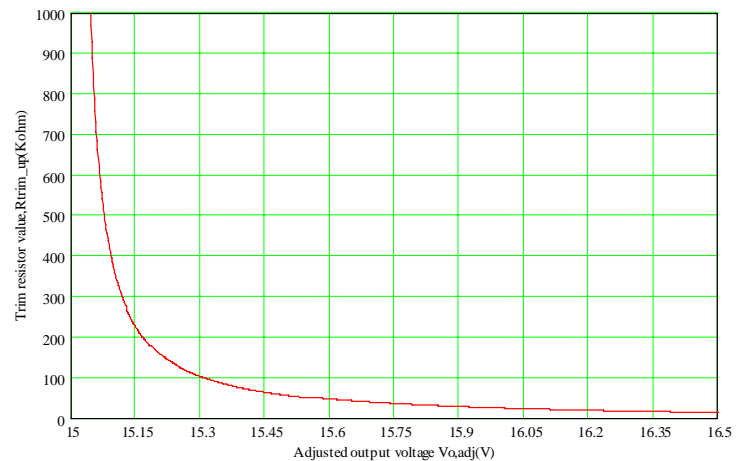
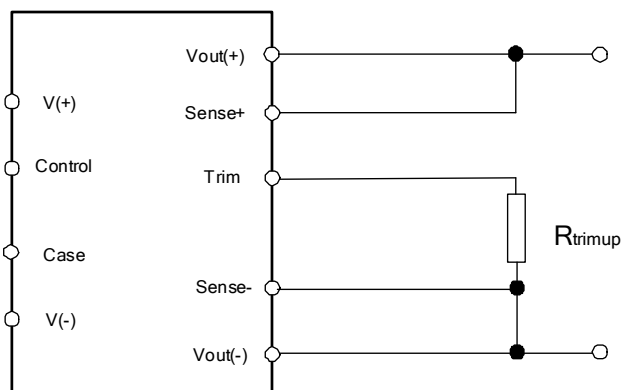

$$R_{trimup} = \frac{31.75}{V_{o\_req} - V_o} - 8.2 [k\Omega]$$

**Note:**  $V_{o\_req}$  = Desired(trimmed) output voltage[V]

Output voltage  $V_o$  = 15.014 V

# ISOLATED DC/DC CONVERTERS

24 Vdc Input 15 Vdc /6.67 A Output



## Efficiency Data

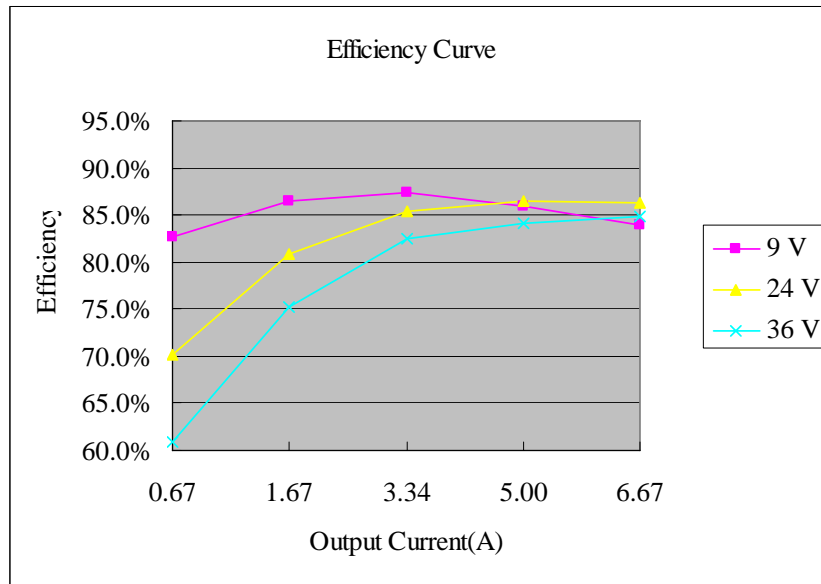

## Thermal Derating Curve

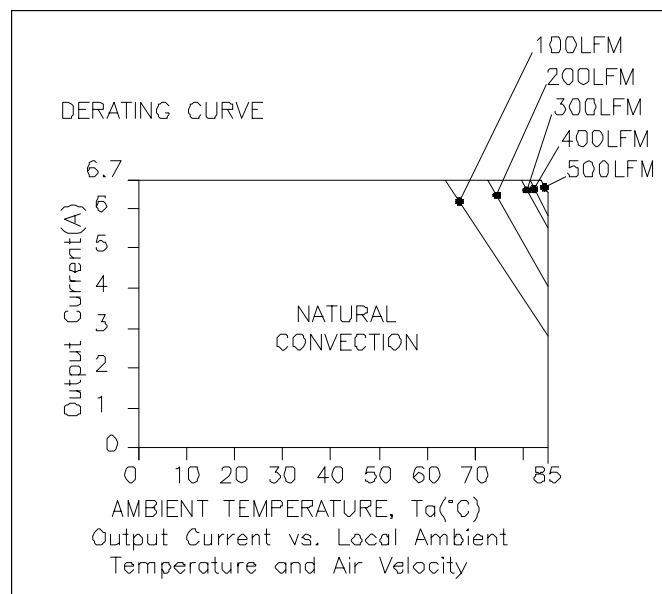

# ISOLATED DC/DC CONVERTERS

24 Vdc Input 15 Vdc /6.67 A Output



## Ripple and Noise Waveforms

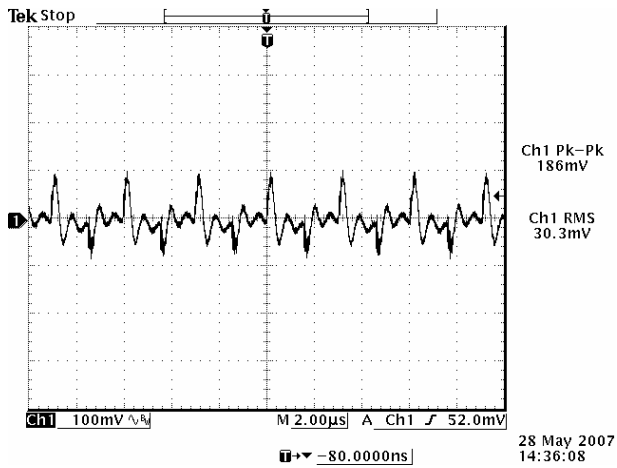

9 Vdc input, 15 Vdc/6.67 A output

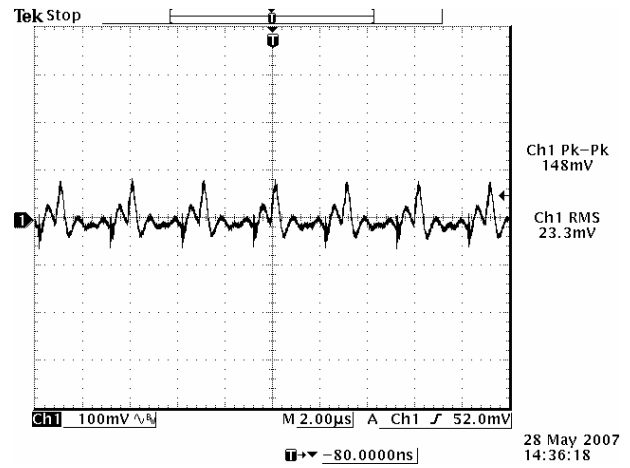

24 Vdc input, 15 Vdc/6.67 A output

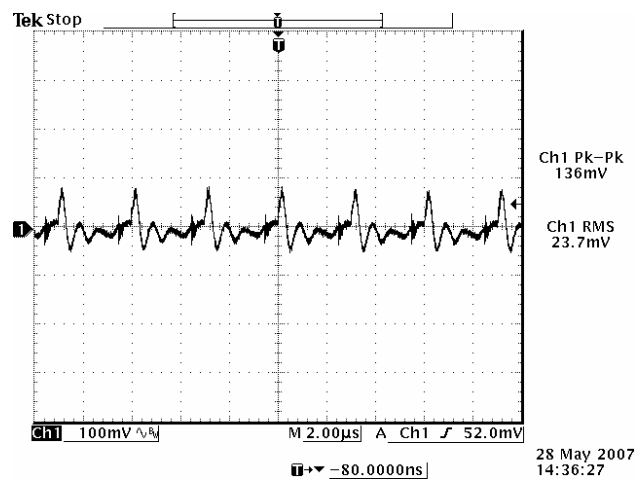

36 Vdc input, 15 Vdc/6.67 A output

**Note:** Ripple and noise at full load, with a 1µF ceramic capacitor at output, and  $T_a=25$  deg C.

# ISOLATED DC/DC CONVERTERS

24 Vdc Input 15 Vdc /6.67 A Output



## Transient Response Waveforms

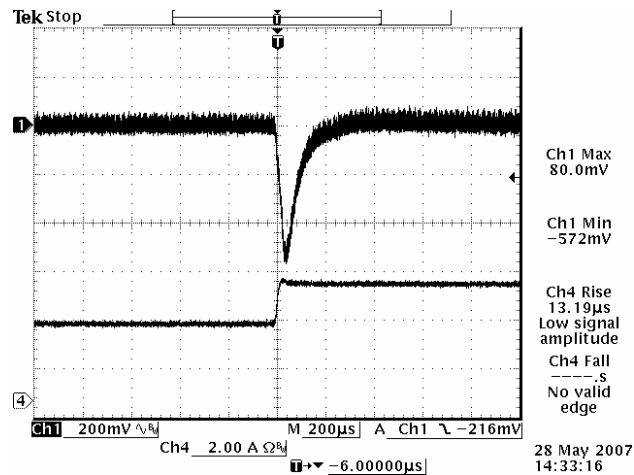

Vout=15 V, 50% to 75% Load Transients

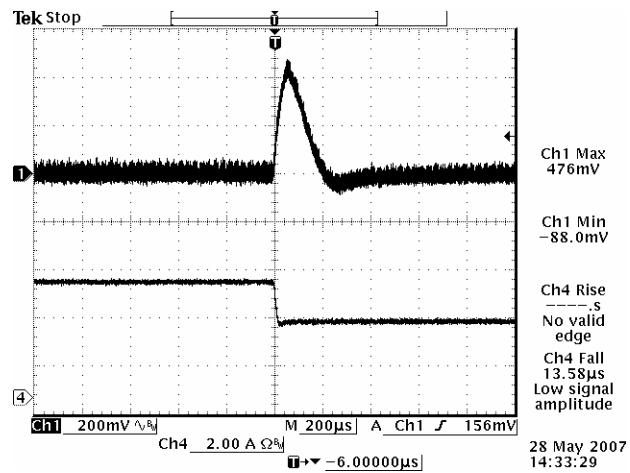

Vout=15 V, 75% to 50% Load Transients

**Note:** Transient Response at  $di/dt=0.1$  A/ $\mu$ s,  $V_{in}=24$  Vdc,  $T_a=25^\circ\text{C}$ , with a  $1\mu\text{F}$  ceramic capacitor at output.

# ISOLATED DC/DC CONVERTERS

24 Vdc Input 15 Vdc /6.67 A Output



## Mechanical Outline

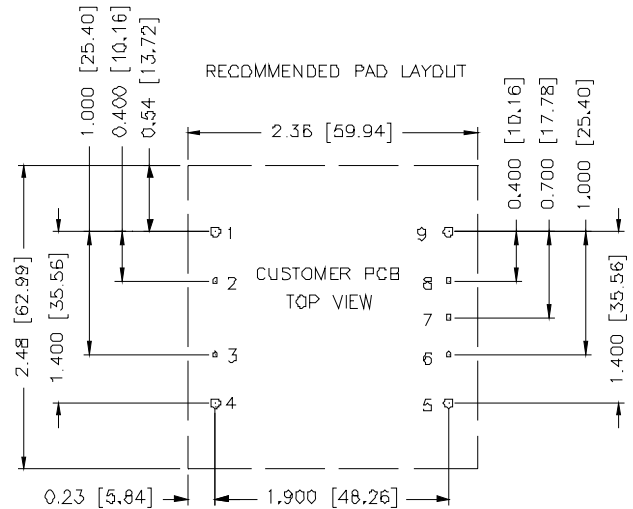
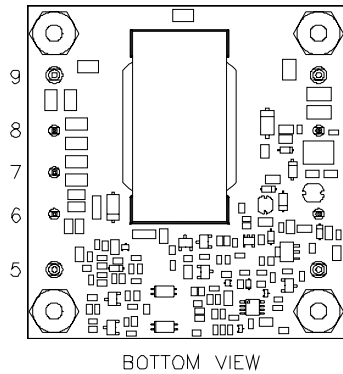
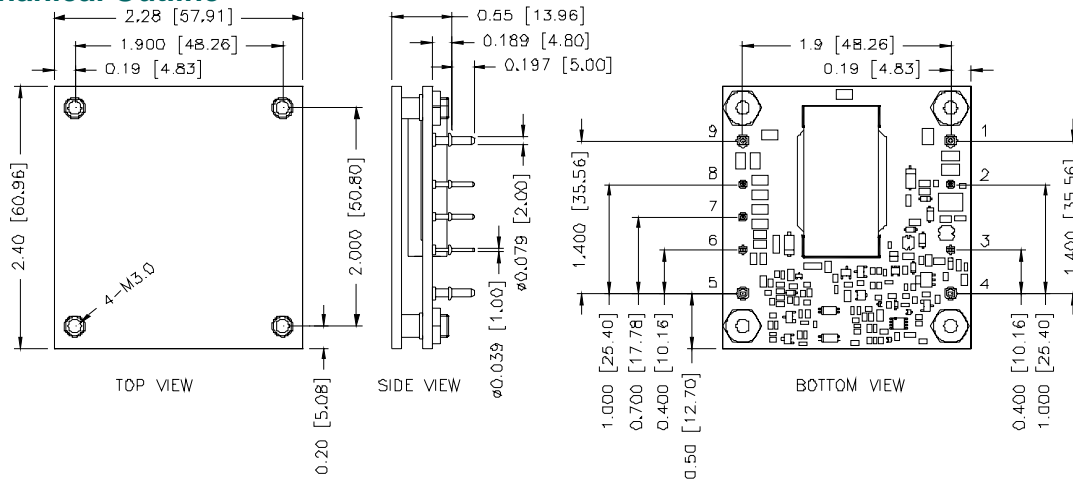

## Pin Connections

Pin	Function	Pin Size	Pin	Function	Pin Size
1	Vin(+)	0.079"	5	Vo(-)	0.079"
2	Control	0.039"	6	Sense(-)	0.039"
3	Case	0.039"	7	Trim	0.039"
4	Vin(-)	0.079"	8	Sense(+)	0.039"
-	-	-	9	Vo(+)	0.079"

- Notes:**
1. Pin 3 must be connected to GND.
  2. Pin 6 must be connected to Vo(-).
  3. Leave pin 7 open for normal voltage.
  4. Pin 8 must be connected to Vo(+).

2,3,6,7,8  $\phi 0.047$  PAD HOLE SIZE.  
 $\phi 0.08$  min PAD SIZE, BOTH SIDE.  
 1,4,5,9  $\phi 0.093$  HOLE SIZE,  
 $\phi 0.12$  min PAD SIZE, BOTH SIDE.

## RoHS Compliance

Complies with the European Directive 2002/95/EC, calling for the elimination of lead and other hazardous substances from electronic products.



©2008 Bel Fuse Inc. Specifications subject to change without notice. 052208

### CORPORATE

**Bel Fuse Inc.**  
 206 Van Vorst Street  
 Jersey City, NJ 07302  
 Tel 201-432-0463  
 Fax 201-432-9542  
[www.belfuse.com](http://www.belfuse.com)

### FAR EAST

**Bel Fuse Ltd.**  
 8F/ 8 Luk Hop Street  
 San Po Kong  
 Kowloon, Hong Kong  
 Tel 852-2328-5515  
 Fax 852-2352-3706  
[www.belfuse.com](http://www.belfuse.com)

### EUROPE

**Bel Fuse Europe Ltd.**  
 Preston Technology Management Centre  
 Marsh Lane, Suite G7, Preston  
 Lancashire, PR1 8UD, U.K.  
 Tel 44-1772-556601  
 Fax 44-1772-888366  
[www.belfuse.com](http://www.belfuse.com)