

ISOLATED DC/DC CONVERTERS

36 Vdc - 75 Vdc Input, 1.2 Vdc /60 A Output



Dec. 18, 2009

Bel Power Inc., a subsidiary of Bel Fuse Inc.

0RQB-72TV2x

RoHS Compliant

Rev.D

- Fixed Frequency (310 kHz)
- Isolated
- High Efficiency
- High Power Density
- Input Under Voltage Protection
- Output Over Voltage Protection
- Over Temperature Protection
- SCP/OCP
- Low Cost
- Remote On/Off
- Class 1, Category 2, Isolated DC/DC Converter (refer to IPC-9592)
- UL60950-1 Recognized (UL/cUL) (Pending)

Applications

- Networking
- Computers and peripherals
- Telecommunications

Description

The 0RQB-72TV2x is an isolated dc/dc converter that operates from a nominal 48 Vdc source. This converter provides up to 72 W of output power. Features include remote on/off, short circuit protection, over current protection, over-temperature protection, output over-voltage protection, input under-voltage protection. This converter is provided in a compact, through-hole package that is easy to use and provides good thermal performance.

Part Selection

Output Voltage	Input Voltage	Max. Output Current	Max. Output Power	Typical Efficiency	Model Number Active High	Model Number Active Low
1.2 V	36 V - 75 V	60 A	72 W	86%	0RQB-72TV20	0RQB-72TV2L

Notes: Add "G" suffix at the end of the model number to indicate "Tray Packaging".

Part Number Explanation

0 R QB - 72 I V2 x
 1 2 3 4 5 6 7

1---Through hole

2---RoHS 6, change "R" to "7" means RoHS 5

3---Series name, 1/4 Brick

4---Series code

5---Input range

6---Output voltage, 1.2Vout

7---Option, "x" of the model part number to be 0-9, A-Z, which will represent the special request of customer.

ISOLATED DC/DC CONVERTERS

36 Vdc - 75 Vdc Input, 1.2 Vdc /60 A Output



Dec. 18, 2009

Bel Power Inc., a subsidiary of Bel Fuse Inc.

Absolute Maximum Ratings

Parameter	Min	Typ	Max	Notes
Input Voltage (continuous)	-0.3 V	-	75 V	
Input Transient Voltage	-	-	100 V	100 mS maximum
Remote On/Off	-0.3 V	-	18 V	
Ambient Temperature	-40 °C	-	85 °C	
Storage Temperature	-55 °C	-	125 °C	

Note: All specifications are typical at 25 °C unless otherwise stated.

Input Specifications

Parameter	Min	Typ	Max	Notes
Input Voltage	36 V	48 V	75 V	
Input Current (no load)	-	60 mA	120 mA	
Input Current (full load)	-	-	2.7 A	
Remote Off Input Current	-	2 mA	5 mA	
Input Reflected Ripple Current (rms)		2 mA	5 mA	With simulated source impedance of 10uH, 5Hz to 20MHz. Use a 100uF/100V electrolytic capacitor with ESR=1 ohm max, at 200KHz @25°C.
Input Reflected Ripple Current (pk-pk)	-	10 mA	20 mA	
I ² t Inrush Current Transient	-	-	1 A ² s	
Turn-on Voltage Threshold	32 V	34 V	35 V	
Turn-off Voltage Threshold	30 V	32 V	34 V	

CAUTION: This converter is not internally fused. An input line fuse must be used in application.

Recommend a fast-acting fuse with maximum rating of 4A on system board. Refer to the fuse manufacture's datasheet for further information.

- Notes:** 1. This converter has internal C-L-C (0.47uF-2.2uH-4.4uF) filter.
2. All specifications are typical at 25 °C unless otherwise stated.

Output Specifications

Parameter	Min	Typ	Max	Notes
Output Voltage Set Point	1.176 V	1.200 V	1.224 V	V _{in} =48 V, I _o =50%Load
Line Regulation	-	5 mV	10 mV	V _{in} =36-75 V, full load
Load Regulation	-	5 mV	10 mV	V _{in} =48 V, I _{out} =0-60 A
Temperature Regulation (-40C~85C)	-	-	±20 mV	
Output Current	0 A	-	60 A	
Current Limit Threshold	65 A	75 A	85 A	
Short Circuit Surge Transient	-	-	80 A ² s	
Ripple and Noise (pk-pk)	-	50 mV	80 mV	0-20MHz BW, with a 1µF ceramic capacitor and a 10uF Tantalum cap at output.
Ripple and Noise (rms)	-	12 mV	18 mV	
Ripple and Noise	-	-	150 mV	over all operating input voltage, load and ambient temperature condition
Rise time	5 mS	-	10 mS	
Turn on Time	-	70 mS	100 mS	

ISOLATED DC/DC CONVERTERS

36 Vdc - 75 Vdc Input, 1.2 Vdc /60 A Output



Dec. 18, 2009

Bel Power Inc., a subsidiary of Bel Fuse Inc.

Output Specifications (continued)

Parameter		Min	Typ	Max	Notes	
Overshoot at Turn on		-	0%	3%		
External load Capacitance		0	-	30000 uF		
Transient Response						
50% ~ 75% Max Load	Overshoot	Vo=1.2 V	-	60 mV	100 mV	di/dt=0.1A/us, Vin=48Vdc, Ta=25°C, with a 1µF ceramic capacitor and a 10uF Tantalum cap at output.
	Settling Time		-	150 uS	200 uS	
75% ~ 50% Max Load	Overshoot		-	60 mV	100 mV	
	Settling Time		-	150 uS	200 uS	

Note: All specifications are typical at nominal input, full load at 25 °C unless otherwise stated.

General Specifications

Parameter	Min	Typ	Max	Notes
Efficiency	84%	86%	-	Vin=48 V, full load
Switching Frequency	290 kHz	310 kHz	330 kHz	
Output Voltage Trim Range	80%	-	110%	
Remote Sense Compensation	-	-	10%	
Over Temperature Protection	-	120 °C	130 °C	
Over Voltage Protection (Static)	1.35 V		1.55 V	
Over Voltage Protection (Dynamic)	-	-	1.8 V	The transient over voltage must be measured at Rtrim-up ≥ 1K
MTBF	-	490	-	Calculated Per Bell Core SR-332 (Vin=48 V, Vo=1.2 V, Io=80%, Ta = 25 °C, FIT=10 ⁹ /MTBF)
Dimensions Inches (L x W x H) Millimeters (L x W x H)	2.30 x 1.45 x 0.45 58.42 x 36.83 x 11.42			
Weight	-	35 g	-	
Isolation characteristics				
Input to Output	-	-	1500 V	
Input to Case	-	-	1500 V	
Output to Case	-	-	500 V	
Isolation Resistance	10M ohm	-		
Isolation Capacitance	-	1500 pF	-	

Note: All specifications are typical at 25 °C unless otherwise stated.

Control Specifications

Parameter	Min	Typ	Max	Notes
Remote On/Off				
Signal Low (Unit On)	-0.3 V	-	0.8 V	The Remote On/Off pin is open, Unit on.
Signal High (Unit Off)				
Signal Low (Unit Off)	-0.3 V	-	0.8 V	The Remote On/Off pin is open, Unit off.
Signal High (Unit On)				
Current Sink	0 mA	-	1 mA	

ISOLATED DC/DC CONVERTERS

36 Vdc - 75 Vdc Input, 1.2 Vdc /60 A Output



Dec. 18, 2009

Bel Power Inc., a subsidiary of Bel Fuse Inc.

Output Trim Equations

Equations for calculating the trim resistor are shown below. The Trim Down resistor should be connected between the Trim pin and Sense(-) pin. The Trim Up resistor should be connected between the Trim pin and the Sense(+) pin. Only one of the resistors should be used for any given application.

$$R_{trim_down} = \frac{1299.1}{\Delta\%} - 33.49 [k\Omega]$$

$$R_{trim_up} = \frac{9.769 \times V_o \times (100 + \Delta\%)}{0.6 \times \Delta\%} - \frac{1299.1}{\Delta\%} - 33.49 [k\Omega]$$

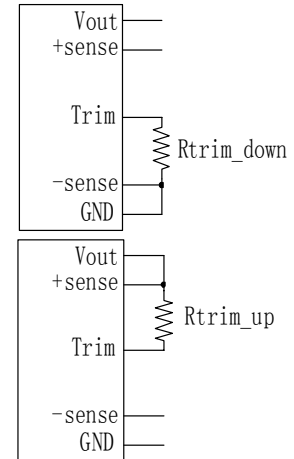

Note:

$$\Delta\% = \left| \frac{V_{DES} - V_o}{V_o} \right| \times 100$$

V_{DES} is the desired output voltage; V_o is the nominal output voltage (1.2V)

Efficiency Data

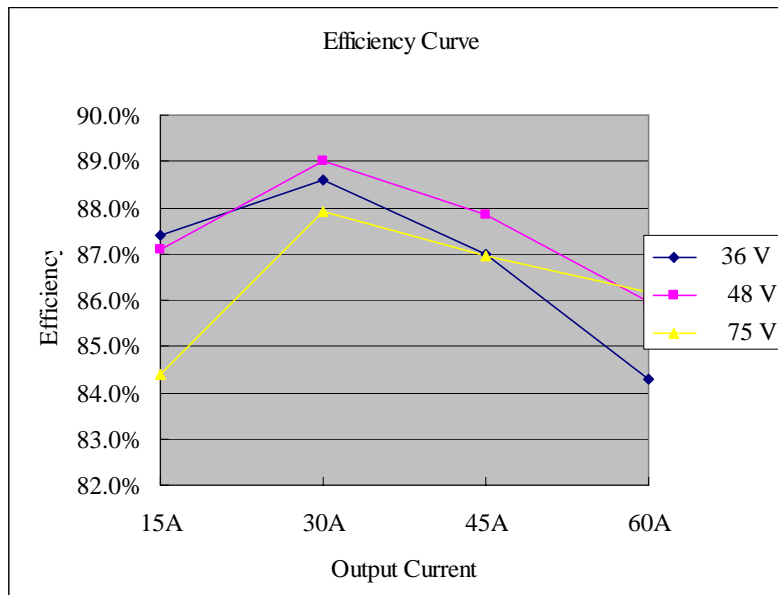

ISOLATED DC/DC CONVERTERS

36 Vdc - 75 Vdc Input, 1.2 Vdc /60 A Output



Dec. 18, 2009

Bel Power Inc., a subsidiary of Bel Fuse Inc.

Thermal Derating Curve

Vin=48 V, with maximum junction temperature of semiconductors derated to 120 degree C.

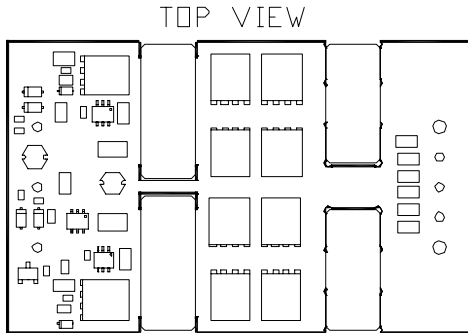

↑
Forced Airflow Direction

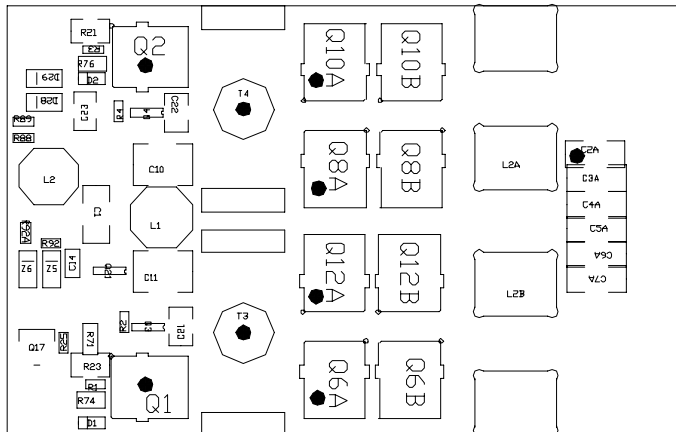
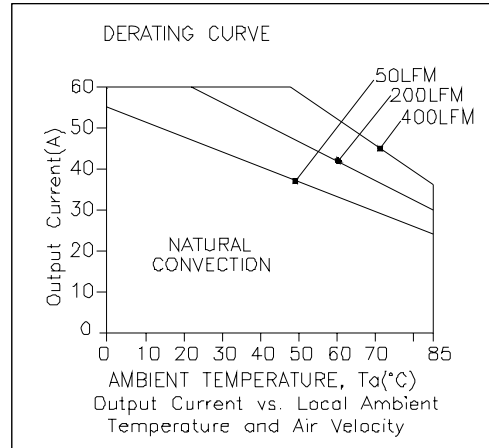

Temperature reference points on top side

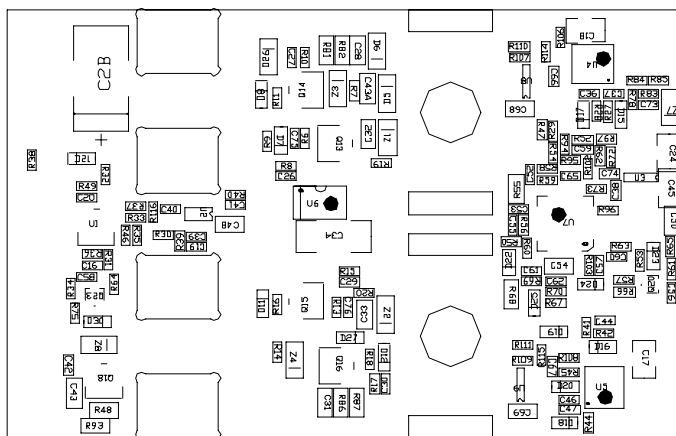

Temperature reference points on bottom side

ISOLATED DC/DC CONVERTERS

36 Vdc - 75 Vdc Input, 1.2 Vdc /60 A Output



Dec. 18, 2009

Bel Power Inc., a subsidiary of Bel Fuse Inc.

Ripple and Noise Waveforms

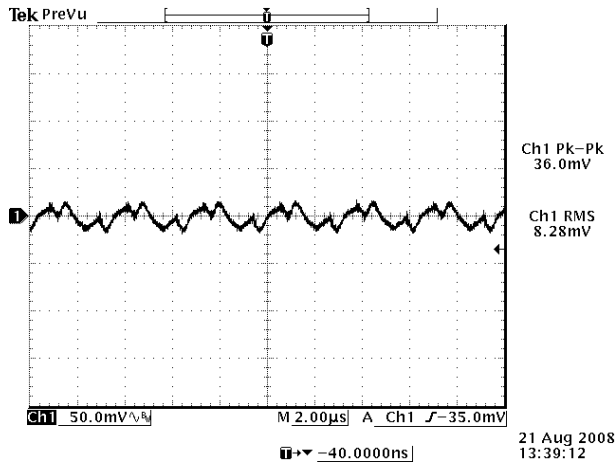

Vin =36 V and Vout = 1.2 V

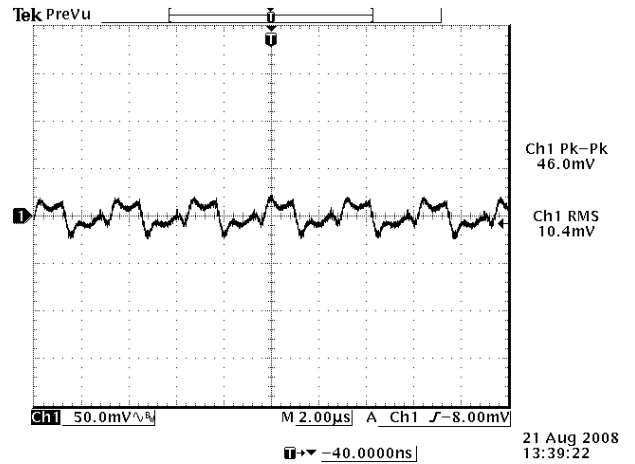

Vin =48 V and Vout = 1.2 V

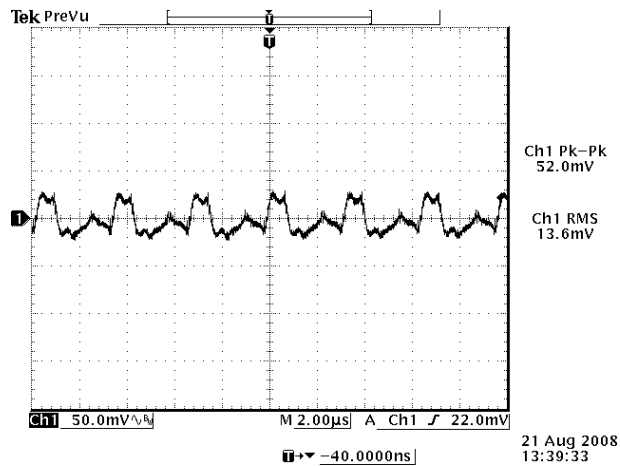

Vin =75 V and Vout = 1.2 V

Note: Ripple and Noise at full load, 0-20 MHz BW, with 10 uF/10 V tantalum and 1uF/50 V ceramic capacitor at the output, and Ta=25 deg C.

ISOLATED DC/DC CONVERTERS

36 Vdc - 75 Vdc Input, 1.2 Vdc /60 A Output



Dec. 18, 2009

Bel Power Inc., a subsidiary of Bel Fuse Inc.

Transient Response Waveforms

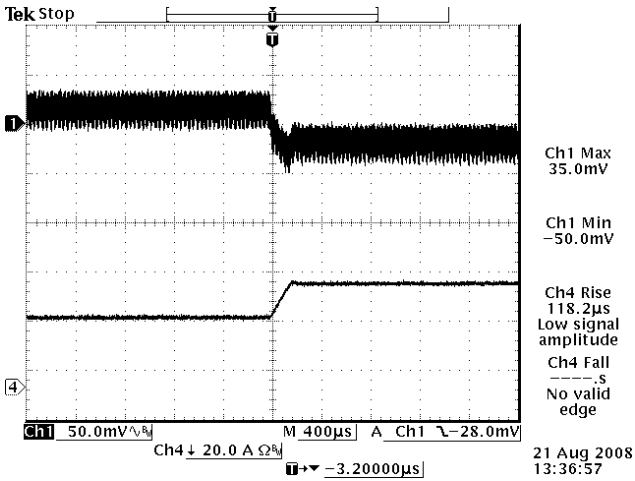

50%-75% Load Transients

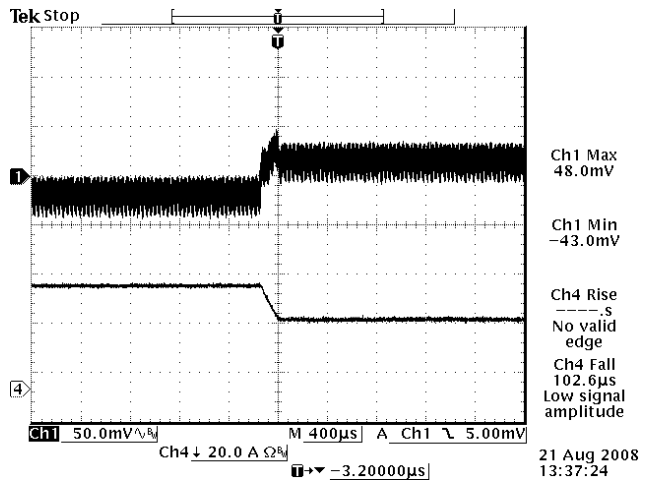

75%-50% Load Transients

Note: Transient response at $V_{in}=48V$, $di/dt=0.1A/\mu s$, with a $10\ \mu F/10\ V$ Tan cap and a $1\ \mu F/50\ V$ ceramic cap at the output, $T_a=25\ deg\ C$.

Startup and Shutdown

Rise time

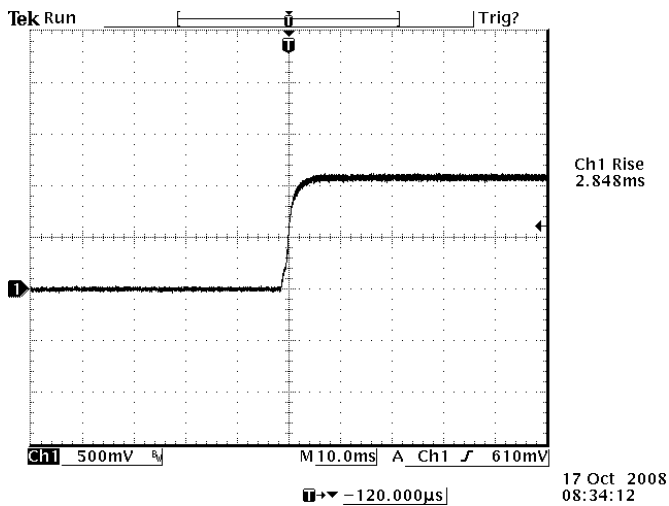

$V_{in}=48V$, $V_o=1.2V$, $I_o=60A$

ISOLATED DC/DC CONVERTERS

36 Vdc - 75 Vdc Input, 1.2 Vdc /60 A Output



Dec. 18, 2009

Bel Power Inc., a subsidiary of Bel Fuse Inc.

Startup and Shutdown (continued)

Startup time

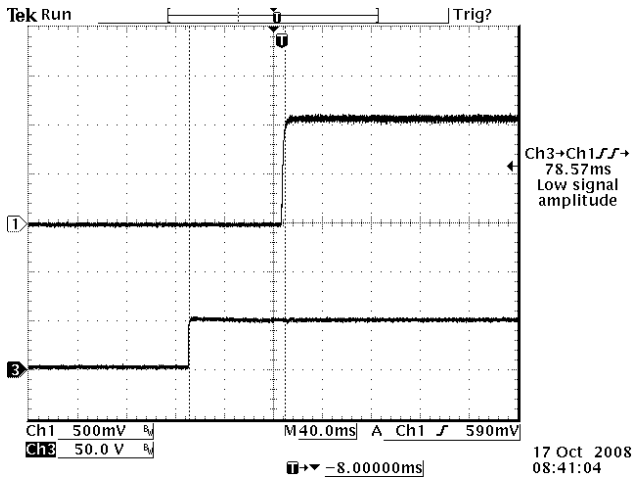

Startup from Vin
Ch1: Vo, Ch3: Vin
Vin=48V, Vo=1.2V, Io=60A

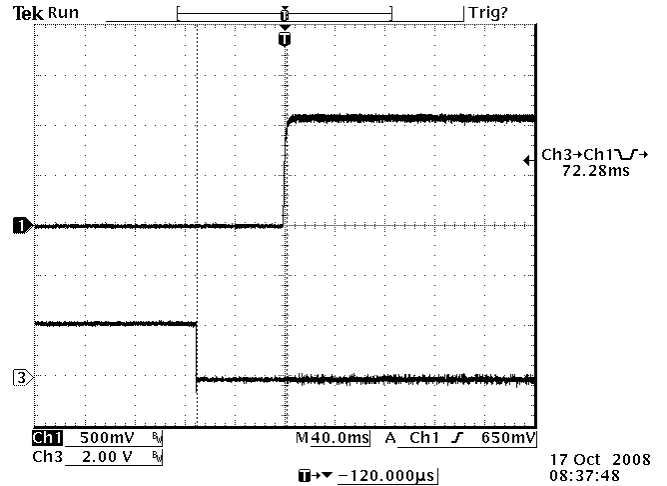

Startup from on/off
Ch1: Vo, Ch3: on/off
Vin=48V, Vo=1.2V, Io=60A

Shutdown

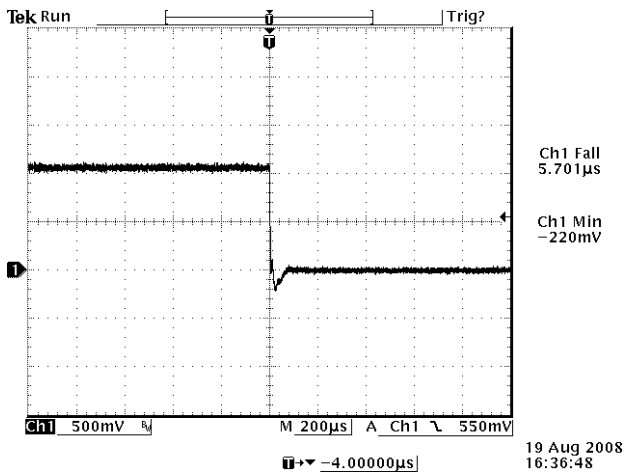

Vin=48V, Vo=1.2V, Io=60A

ISOLATED DC/DC CONVERTERS

36 Vdc - 75 Vdc Input, 1.2 Vdc /60 A Output



Dec. 18, 2009

Bel Power Inc., a subsidiary of Bel Fuse Inc.

Safety & EMC

Safety

1. Material flammability UL94V-0
2. UL Certification UL60950-1

EMC

1. Surge IEC61000-4-5
2. DC-DIP IEC61000-4-29
3. Conductive EMI EN55022 class A

Compliance to EN55022 class A (both q.peak and average) with the following inductive and capacitive filter

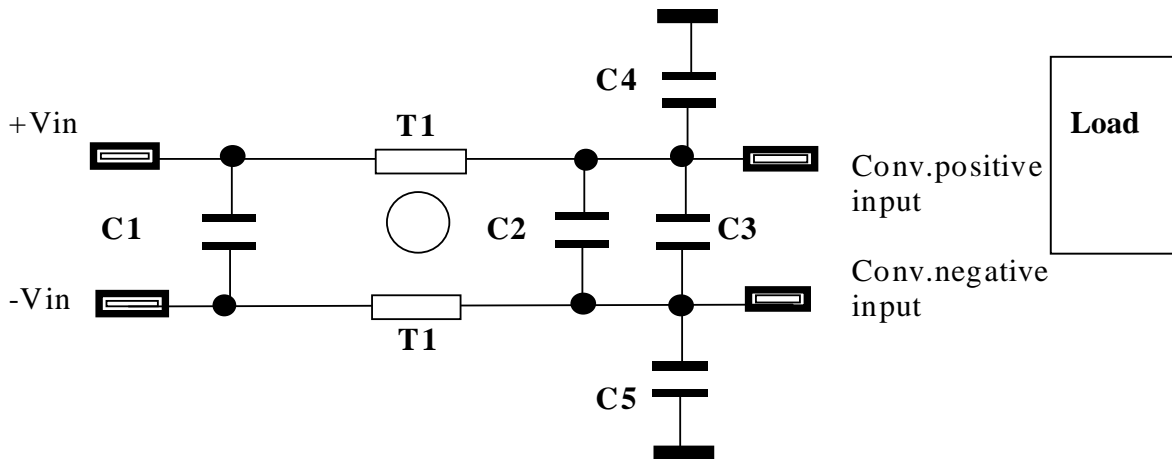

Item	Designator	Parameter	Vendor	Vendor P/N
1	C1	1uF/100V,ceramic	Murata	GRM32ER72A105KA01L
2	C2	0.1uF/100V, ceramic	TDK	C3216X7R2A104K
3	C3	100uF/100V, AL cap	Nichicon	UVZ2A101MPD
4	C4	2200pF/2000V,ceramic	Johanson	631R15W222KV4TE
5	C5	2200pF/2000V,ceramic	Johanson	631R15W222KV4TE
6	T1	1.3mH, common mode	Pulse	P0402NL

ISOLATED DC/DC CONVERTERS

36 Vdc - 75 Vdc Input, 1.2 Vdc /60 A Output



Dec. 18, 2009

Bel Power Inc., a subsidiary of Bel Fuse Inc.

Safety & EMC (continued)

Positive:

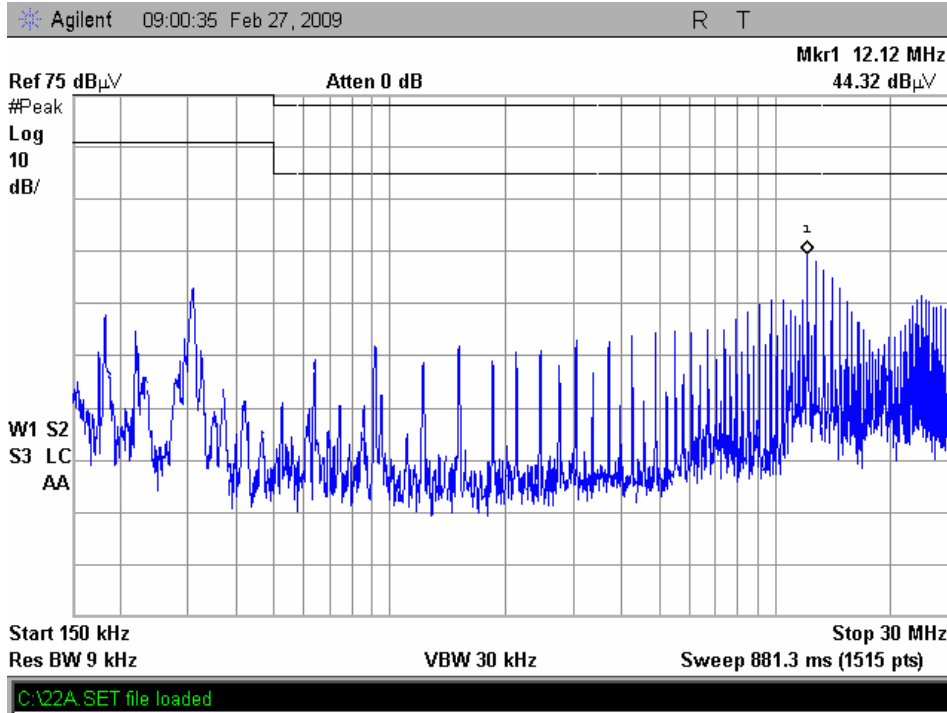

Negative:

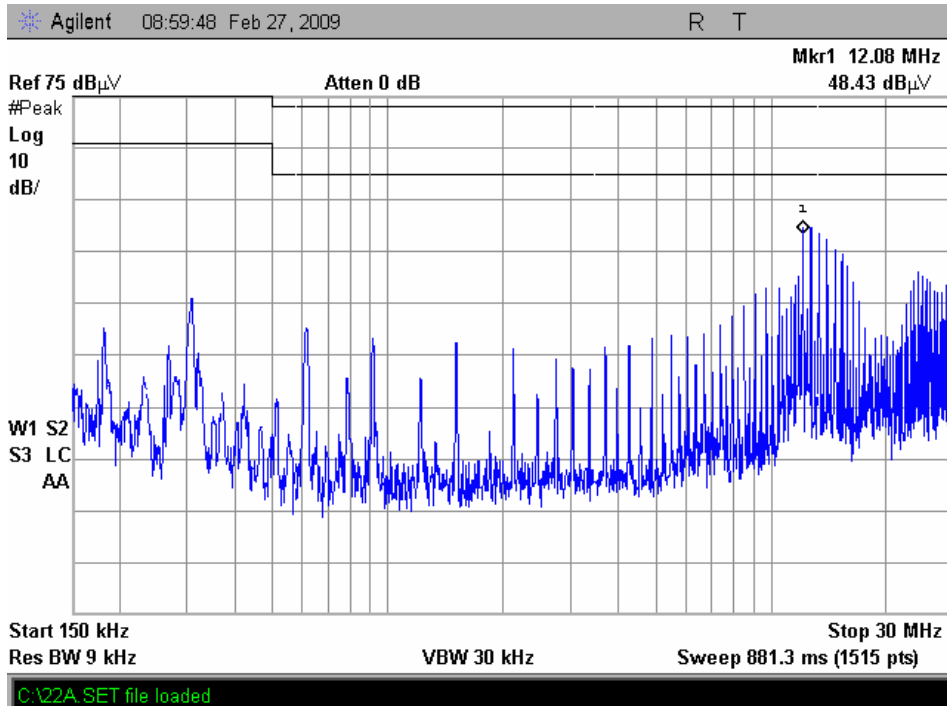

ISOLATED DC/DC CONVERTERS

36 Vdc - 75 Vdc Input, 1.2 Vdc /60 A Output



Dec. 18, 2009

Bel Power Inc., a subsidiary of Bel Fuse Inc.

Mechanical Outline

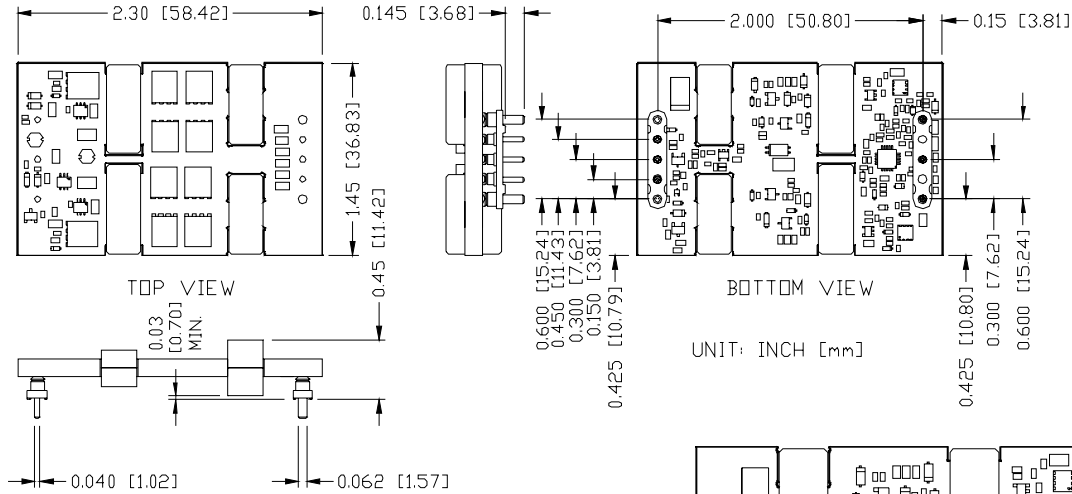

RECOMMENDED PAD LAYOUT

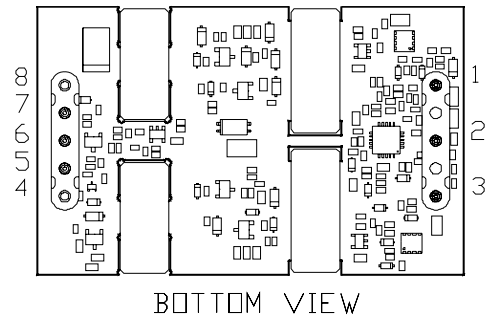
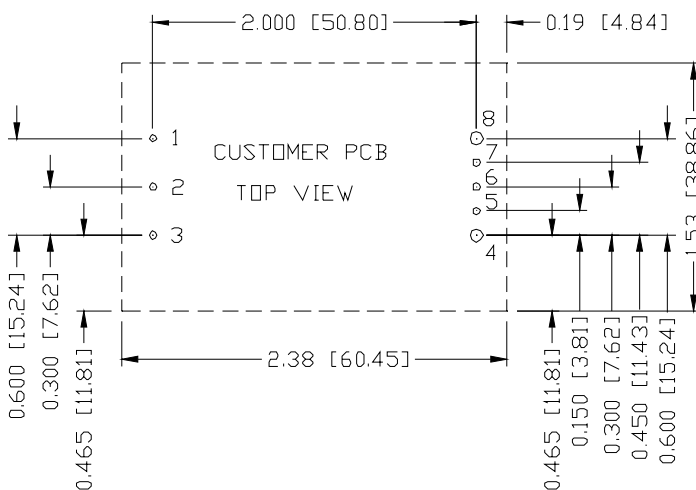

Pin Connections

Pin	Name	Pin Dia
1	Vin+	0.040"
2	On/Off	0.040"
3	Vin-	0.040"
4	Vout-	0.060"
5	Sense-	0.040"
6	Trim	0.040"
7	Sense+	0.040"
8	Vout+	0.060"

1,2,3,5,6,7 ϕ 0.047 HOLE SIZE, ϕ 0.08 min PAD SIZE
4,8 ϕ 0.07 HOLE SIZE, ϕ 0.10 min PAD SIZE

Notes: 1. Pin 5 must be connected to Vout-.
2. Pin 7 must be connected to Vout+.

RoHS Compliance

Complies with the European Directive 2002/95/EC, calling for the elimination of lead and other hazardous substances from electronic products.



©2009 Bel Fuse Inc. Specifications subject to change without notice. 121809

CORPORATE

Bel Fuse Inc.
206 Van Vorst Street
Jersey City, NJ 07302
Tel 201-432-0463
Fax 201-432-9542
www.belfuse.com

FAR EAST

Bel Fuse Ltd.
8F/ 8 Luk Hop Street
San Po Kong
Kowloon, Hong Kong
Tel 852-2328-5515
Fax 852-2352-3706
www.belfuse.com

EUROPE

Bel Fuse Europe Ltd.
Preston Technology Management Centre
Marsh Lane, Suite G7, Preston
Lancashire, PR1 8UD, U.K.
Tel 44-1772-556601
Fax 44-1772-888366
www.belfuse.com