

## ISOLATED DC/DC CONVERTERS

36 Vdc - 75 Vdc Input 3.3 Vdc /15 A Output, 1/8 Brick Converter

**bel**  
POWER PRODUCTS

**0RCB-60T03B Rev.B RoHS Compliant File Rev.A**

- Isolated
- High Efficiency
- High Power Density
- Fixed Frequency (300 kHz)
- Low Cost
- Input Under-Voltage Lockout
- UL60950-1 Recognized
- Pre-Bias Start Up
- Output Over-Voltage Shutdown
- OCP/SCP
- Over Temperature Protection
- Remote On/Off
- Output Voltage Trim
- Positive/Negative Remote Sense
- Basic Insulation

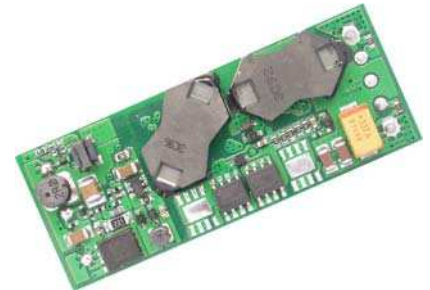

### Description

The 0RCB-60T03B is isolated dc/dc converter that operates from a nominal 48 Vdc source. This unit will provide up to 49.5 W of output power from a nominal 48 Vdc input. This unit is designed to be highly efficient and low cost. Features include remote on/off, over current protection and under-voltage lockout. This converter is provided in an industry standard eighth brick package.

### Part Selection

Output Voltage	Input Voltage	Max. Output Current	Max. Output Power	Typical Efficiency	Model Number Active Low
3.3 Vdc	36 Vdc - 75 Vdc	15 A	49.5 W	90%	0RCB-60T03B

**Notes:** 1. Add "G" suffix at the end of the model number to indicate Tray Packaging.

2. All part numbers above indicate RoHS 6. Change the second letter "R" to "7" for RoHS 5 part numbers.

### Absolute Maximum Ratings

Parameter	Min	Typ	Max	Notes
Input Voltage (continuous)	-0.3 V	-	80 V	
Input Voltage Transient Protection	-	-	100 V	Operating for 100mS
Remote On/Off	-0.3 V	-	18 V	
I/O Isolation Voltage	-	-	1500 V	
Input to Each Output Resistance	10M ohm	-	-	
Ambient Temperature	-40 °C	-	85 °C	
Storage Temperature	-55 °C	-	125 °C	

### Input Specifications

Parameter	Min	Typ	Max	Notes
Input Voltage	36 V	48 V	75 V	
Input Current (full load)	-	-	1.8 A	
Input Current (no load)	-	-	80 mA	
Input Reflected Ripple Current (pk-pk)	-	-	15 mA	Tested with simulated source impedance of 10 uH, 5 Hz to 20 MHz; use a 47 uF/100 V electrolytic capacitor with ESR = 1 ohm max. at 200 kHz at 25 °C.
Input Fuse (not internally)	-	-	5.0 A	
I <sup>2</sup> t Inrush Current Transient	-	-	0.1 A <sup>2</sup> s	
Turn-on Voltage Threshold	32 V	-	35 V	
Turn-off Voltage Threshold	28.5 V	-	31.7 V	

## ISOLATED DC/DC CONVERTERS

36 Vdc - 75 Vdc Input 3.3 Vdc /15 A Output, 1/8 Brick Converter



### Output Specifications

Parameter	Min	Typ	Max	Notes	
Output Voltage Range	3.201 V	3.3 V	3.399 V	Over all line, load & temperature conditions.	
Output Voltage Trim Range	2.97 V	-	3.63 V		
Output Over-Voltage Clamp Non-Latching	3.69 V	-	4.62 V		
Output Current	-	-	15 A		
Current Limit Threshold	15.2 A	-	26 A		
External Admissible Capacitive Load	0 uF	-	10000 uF		
Ripple and Noise (pk-pk)	-	-	130 mV	Vin=72 V, max load on output, 20 MHz BW, 10uF tantalum and 1uF ceramic capacitor.	
Turn on Time	-	-	220 mS		
Rise Time	-	-	15 mS		
<b>Transient Response</b>					
50% ~ 75% ~ 50% Max Load	Vpk-pk	-	-	230 mV	di/dt=0.1A/us, Vin=48Vdc, Ta=25°C, with a 1uF ceramic capacitor and a 10uF Tantalum cap at the output.
	Settling Time	-	-	200 uS	

**Note:** All specifications are typical at 25 °C unless otherwise stated.

### General Specifications

Parameter	Min	Typ	Max	Notes
Efficiency	87%	90%	-	Measured with full load at all conditions.
Switching Frequency	270 kHz	300 kHz	330 kHz	
Isolation capacitance	-	3900 pF	-	
Remote Sense Compensation	-	-	10%	The total voltage increased by trim and remote sense should not exceed 10%Vo.
Over Temperature Protection	-	125 °C	-	
MTBF	2,370,000 hours			Calculated Per Bell Core SR-332 (Vin=48 V, Vo=3.3 V, Io=12 A, Ta = 25 °C)
Dimensions Inches (L x W x H) Millimeters (L x W x H)	2.30 x 0.896 x 0.374 58.42 x 22.76 x 9.50			
Weight	-	26 g	-	

**Note:** All specifications are typical at 25 °C unless otherwise stated.

### Control Specifications

Parameter	Min	Typ	Max	Notes
<b>Remote On/Off</b>				
Signal Low (Unit On)	Active Low	-0.3 V	-	0RCB-60T03B. The remote on/off pin open, Unit off.
Signal High (Unit Off)		2.4 V	-	
Current Sink	0 mA	-	1 mA	

# ISOLATED DC/DC CONVERTERS

36 Vdc - 75 Vdc Input 3.3 Vdc /15 A Output, 1/8 Brick Converter



## Output Trim Equations

Equations for calculating the trim resistor are shown below. The Trim Down resistor should be connected between the Trim pin and Sense (-) pin. The Trim Up resistor should be connected between the Trim pin and the Sense (+) pin. Only one of the resistors should be used for any given application.

$$R_{trimdown} = \frac{511}{|\delta|} - 10.22 [k\Omega]$$

$$R_{trimup} = \left( \frac{(100 + \delta) \cdot V_o \cdot 5.11}{1.225 \cdot \delta} - \frac{511}{\delta} - 10.22 \right) [k\Omega]$$

Note:

$$\delta = \frac{(V_{o\_req} - V_o)}{V_o} \times 100 [\%]$$

$V_{o\_req}$  = Desired (trimmed) output voltage [V]  
 Output voltage  $V_o$  = 3.305 V

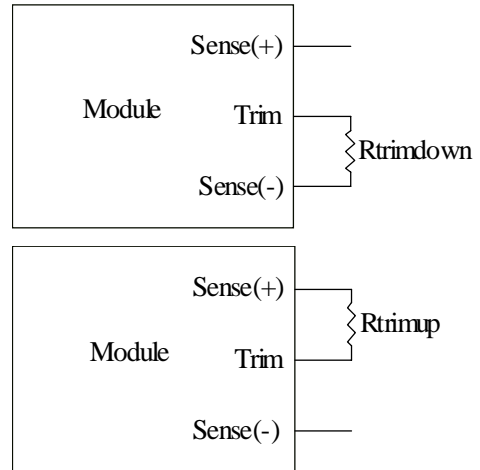

## Efficiency Data

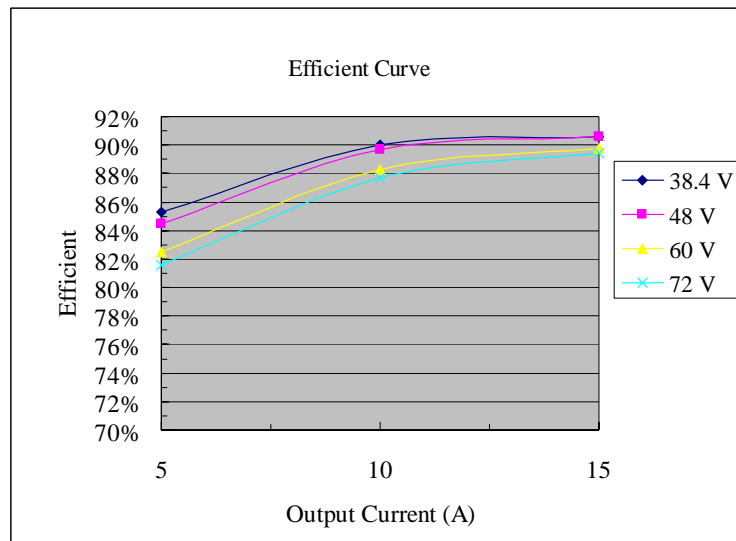

ORCB-60T03B

## ISOLATED DC/DC CONVERTERS

36 Vdc - 75 Vdc Input 3.3 Vdc /15 A Output, 1/8 Brick Converter

**bel**  
POWER PRODUCTS

### Thermal Derating Curves

Vin=48V, with maximum junction temperature of semiconductors derated to 120 degree C.

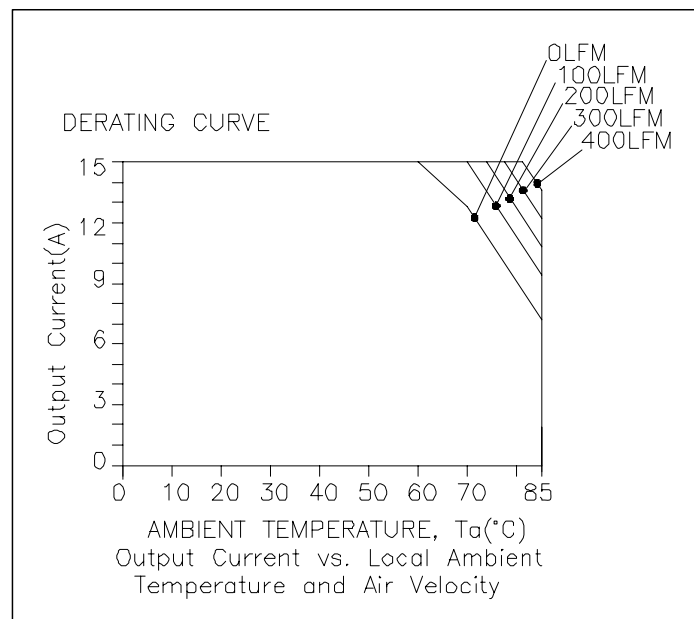
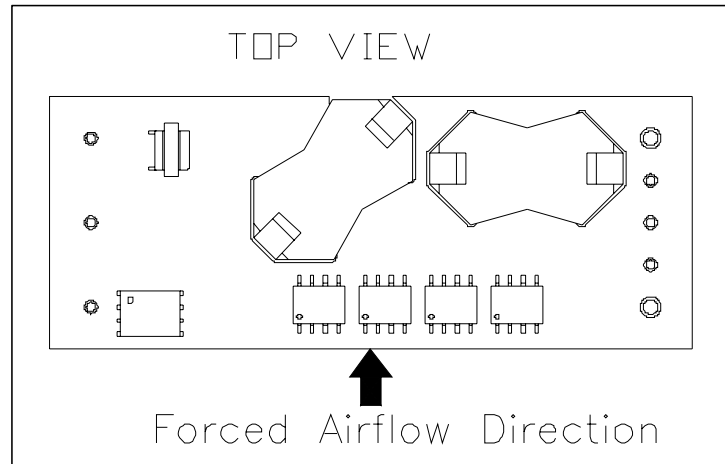

ORCB-60T03B

# ISOLATED DC/DC CONVERTERS

36 Vdc - 75 Vdc Input 3.3 Vdc /15 A Output, 1/8 Brick Converter



## Thermal Derating Curves (continued)

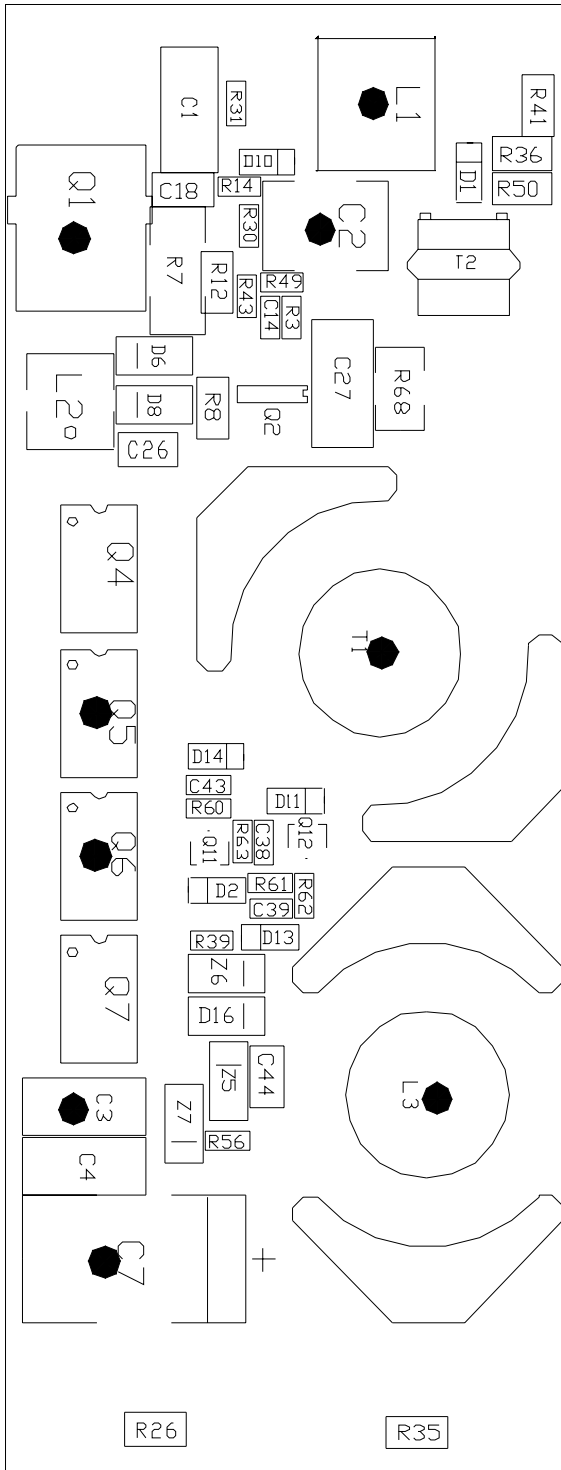

Temperature reference points on top side

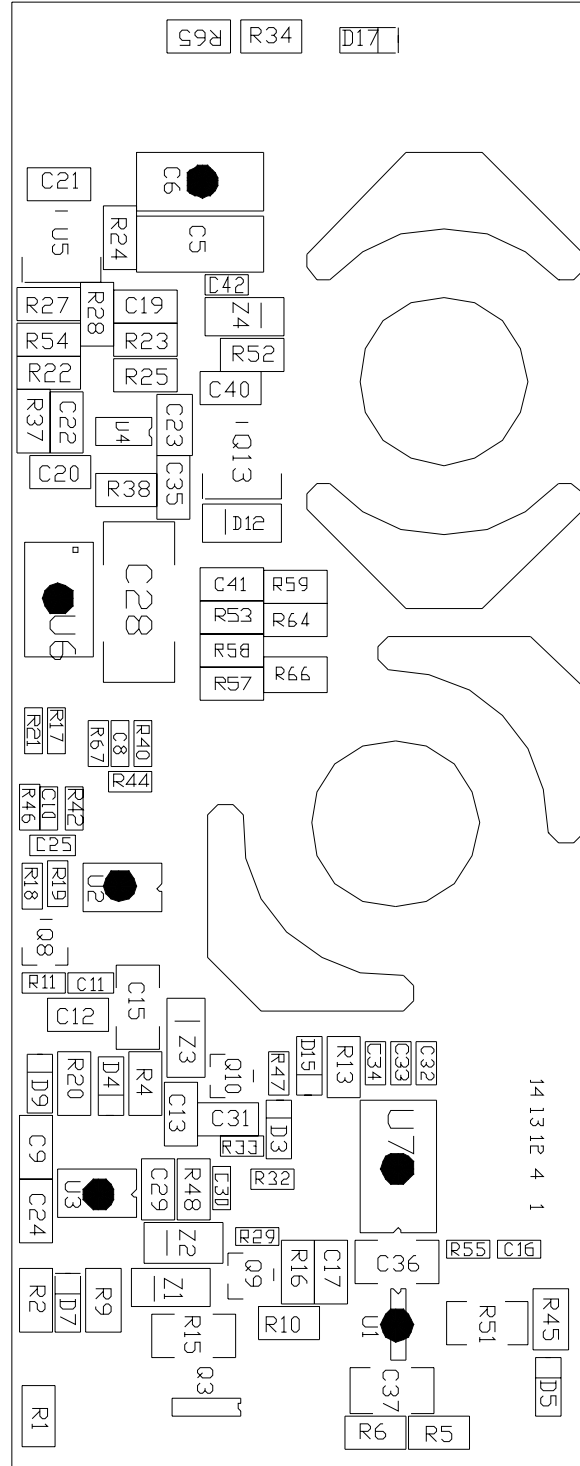

Temperature reference points on bottom side

# ISOLATED DC/DC CONVERTERS

36 Vdc - 75 Vdc Input 3.3 Vdc /15 A Output, 1/8 Brick Converter



## Safety

Material flammability: UL94V-0

Electromagnetic Compatibility EMC

1. Electric field IEC801-3(1984), IEC1000-4-3
2. Fast transient/burst IEC801-4(1988), IEC1000-4-4

Input RFI level conducted and radiated (subject to test by customer)

Compliance to EN55022 class A (both q.peak and average) with the following inductive and capacitive filter

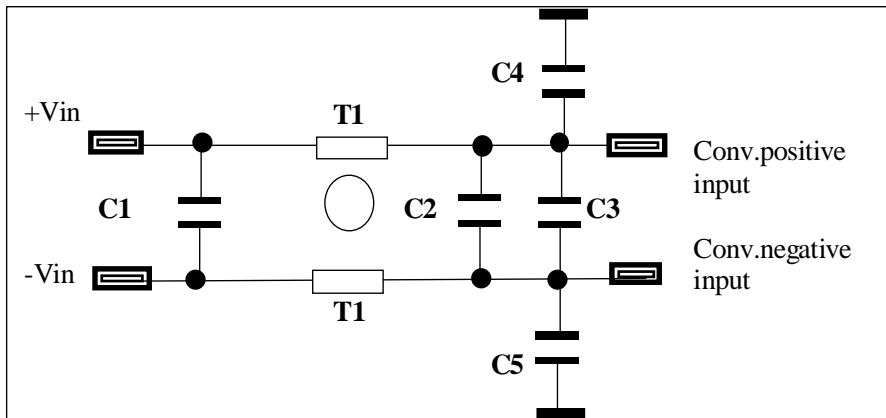

C1=3.3 uF /100 V;  
C2=C3= 47 uF/100 V;  
C4=C5=1000 pF/250 Volt;  
T1=3 mH.

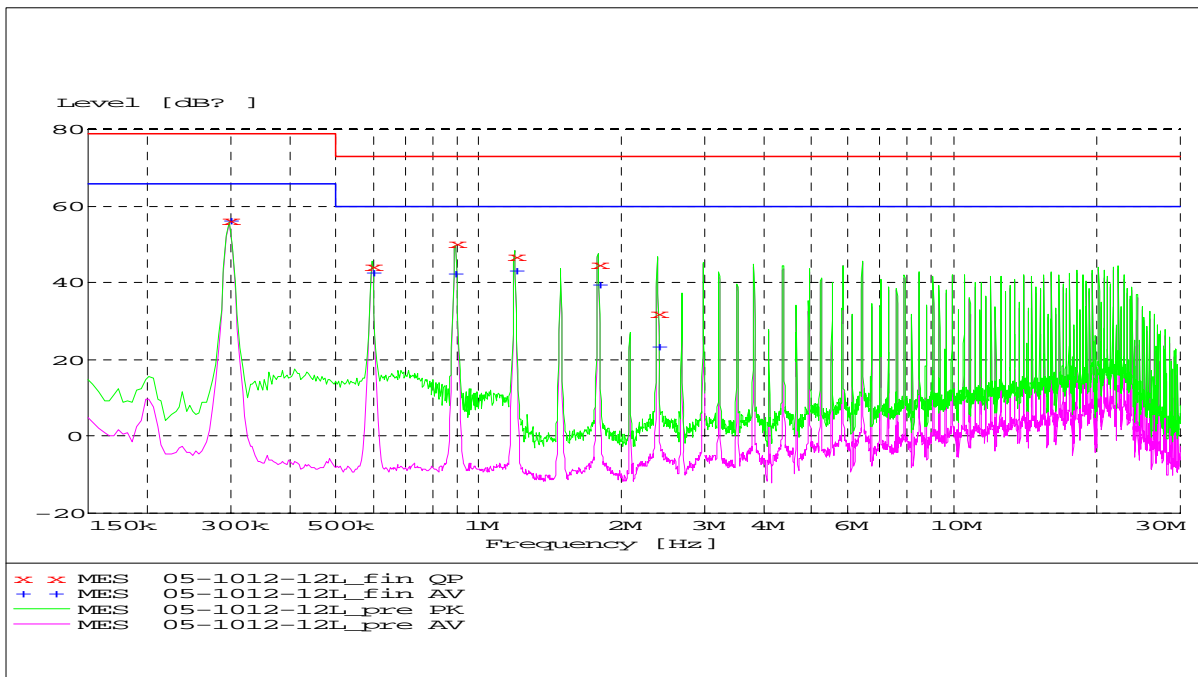

# ISOLATED DC/DC CONVERTERS

36 Vdc - 75 Vdc Input 3.3 Vdc /15 A Output, 1/8 Brick Converter



## Transient Response Waveforms

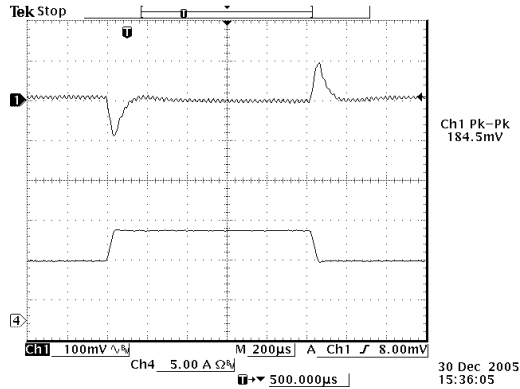

**Note:** Dynamic load transient at  $V_{in} = 48\text{ V}$ ,  $T_a = 25\text{ }^\circ\text{C}$ ,  $I_o = (50\% \sim 75\% \sim 50\%) I_{onom}$ ,  $di/dt = 0.1\text{ A}/\mu\text{s}$ .

## Ripple and Noise Waveforms

$C_1 = 10\text{ }\mu\text{F}$  tantalum,  $C_2 = 1\text{ }\mu\text{F}$  ceramic;  
 $R = 50\text{ ohm}$ ;  
 $C = 220\text{ nF}$

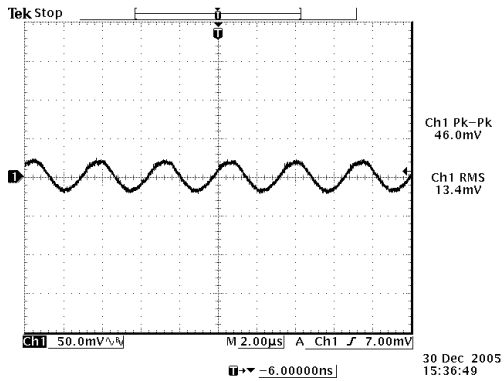
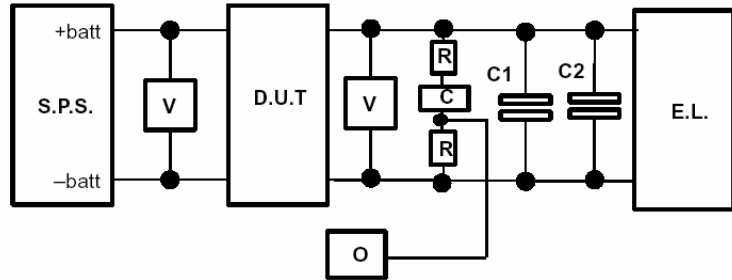

$V_{in} = 38.4\text{ V}$  and  $I_{out} = 15\text{ A}$

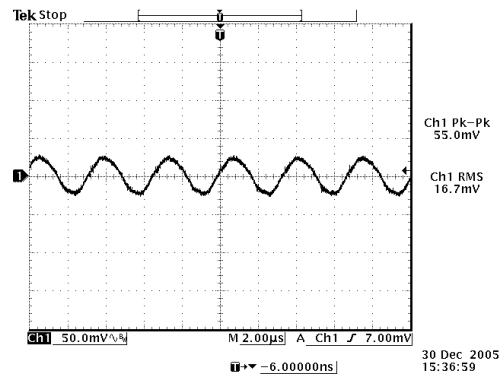

$V_{in} = 48\text{ V}$  and  $I_{out} = 15\text{ A}$

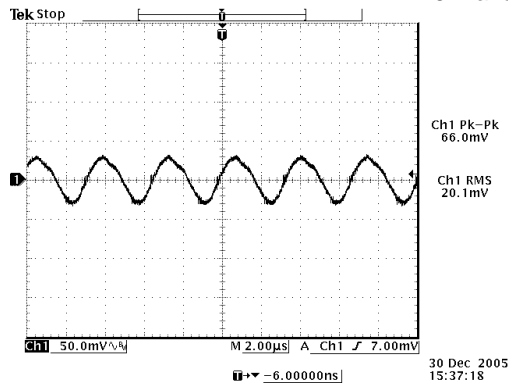

$V_{in} = 72\text{ V}$  and  $I_{out} = 15\text{ A}$

# ISOLATED DC/DC CONVERTERS

36 Vdc - 75 Vdc Input 3.3 Vdc /15 A Output, 1/8 Brick Converter



## Mechanical Outline

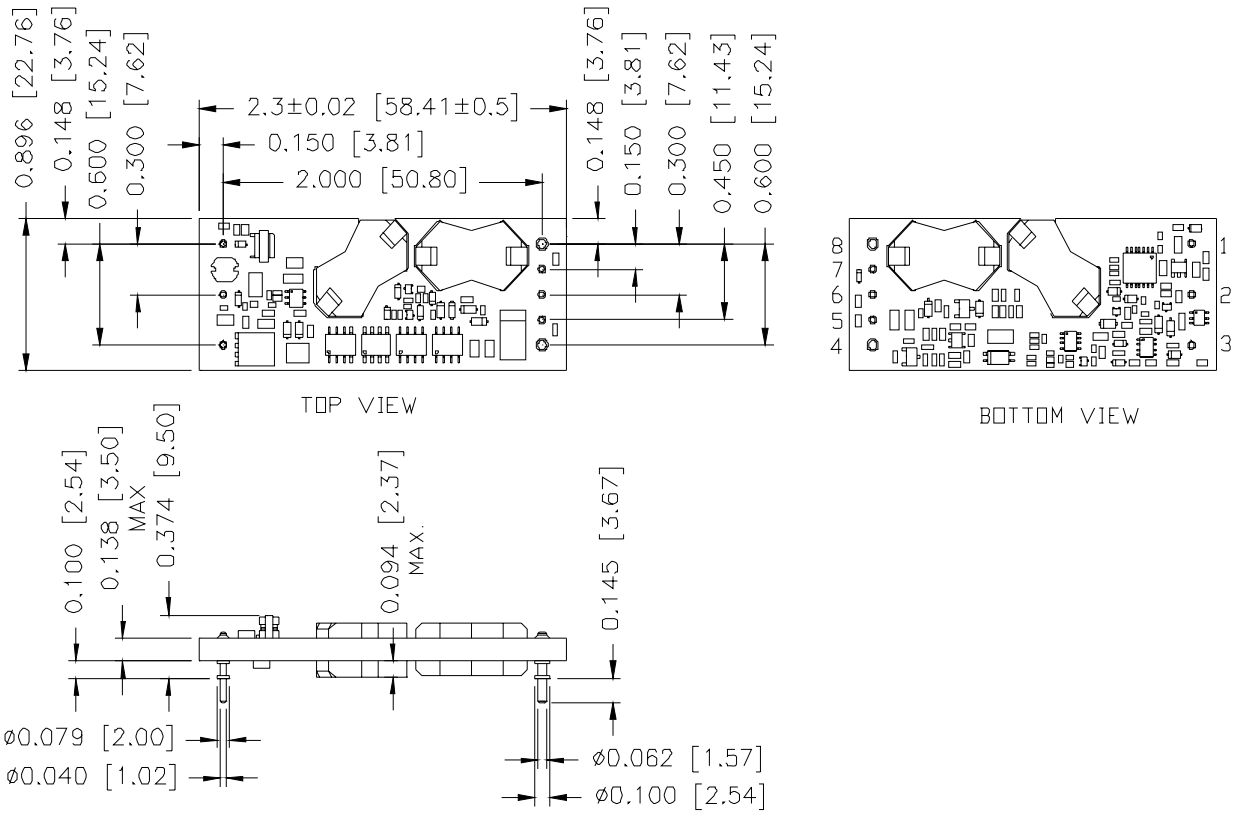

**Note:** The module doesn't guarantee at least 0.7mm as clearance distance on bottom side. This issue should be considered if any copper traces are on the top side of the user's board.

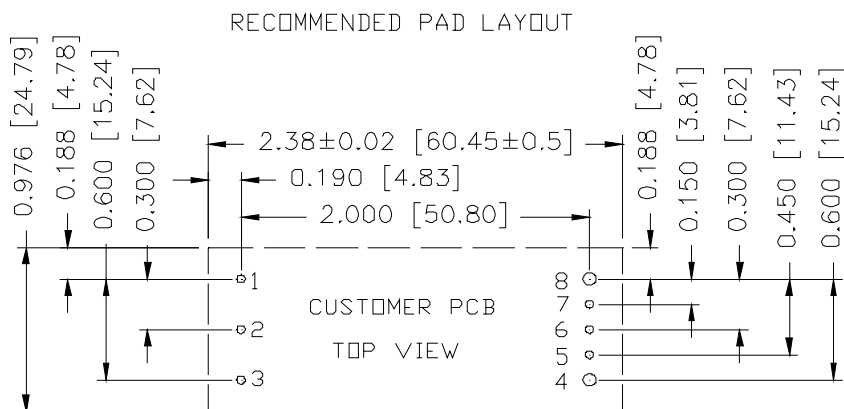

1,2,3,5,6,7 Ø0.047 HOLE SIZE, Ø0.08 min PAD SIZE  
 4,8 Ø0.07 HOLE SIZE, Ø0.10 min PAD SIZE



# ISOLATED DC/DC CONVERTERS

36 Vdc - 75 Vdc Input 3.3 Vdc /15 A Output, 1/8 Brick Converter



## Pin Connections

Pin	Name	Function	Pin Dia
1	Vin+	Positive input voltage	0.040"
2	On/Off	Input to turn converter on and off, referenced to Vin-	0.040"
3	Vin-	Negative input voltage	0.040"
4	Vout-	Negative output voltage	0.062"
5	Sense-	Negative remote sense	0.040"
6	Trim	Output voltage trim	0.040"
7	Sense+	Positive output voltage	0.040"
8	Vout+	Positive output voltage	0.062"

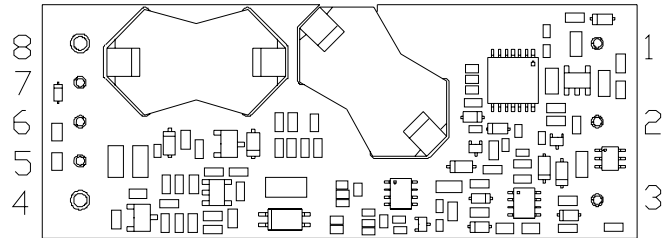

BOTTOM VIEW

- Notes:**
1. Pin 5 must be connected to Vout-.
  2. Leave Pin 6 open for nominal voltage.
  3. Pin 7 must be connected to Vout+.

## Fundamental Circuit Diagram

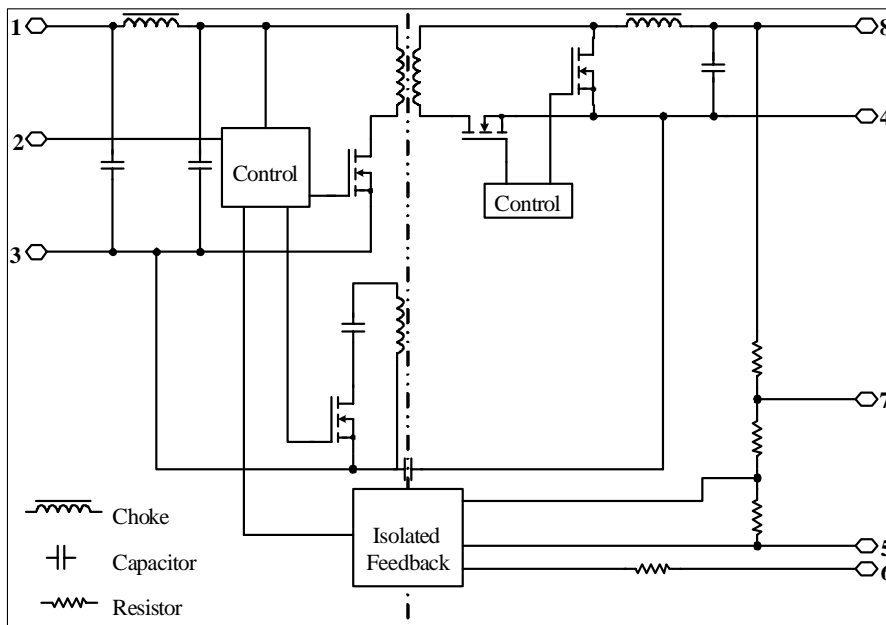

## RoHS Compliance

Complies with the European Directive 2002/95/EC, calling for the elimination of lead and other hazardous substances from electronic products.



©2010 Bel Fuse Inc. Specifications subject to change without notice. 041910

### CORPORATE

**Bel Fuse Inc.**  
206 Van Vorst Street  
Jersey City, NJ 07302  
Tel 201-432-0463  
Fax 201-432-9542  
[www.belfuse.com](http://www.belfuse.com)

### FAR EAST

**Bel Fuse Ltd.**  
8F/ 8 Luk Hop Street  
San Po Kong  
Kowloon, Hong Kong  
Tel 852-2328-5515  
Fax 852-2352-3706  
[www.belfuse.com](http://www.belfuse.com)

### EUROPE

**Bel Fuse Europe Ltd.**  
Preston Technology Management Centre  
Marsh Lane, Suite G7, Preston  
Lancashire, PR1 8UD, U.K.  
Tel 44-1772-556601  
Fax 44-1772-888366  
[www.belfuse.com](http://www.belfuse.com)