

System Lens Drivers

Microstep system Lens Driver for Digital Still Cameras



BU24035GW

●General Description

BU24035GW is the system Lens Driver corresponding to the Microstep driving, making it possible to configure the sophisticated, high precision and low noise lens driver system. Microstep controller is incorporated into IC, making it possible to cut down CPU power. In addition, drivers for DC motor and voice coil motor are built in. Multifunctional lens can be applied.

●Key Specifications

- Digital power supply voltage: 2.7V to 3.6V
- Driver power supply voltage: 2.7V to 5.5V
- Output current (1-4,6ch): ±500mA(Max.)
- Output current (5ch): ±600mA(Max.)
- Input clock frequency: 1MHz to 28MHz
- FET ON resistance (1-4ch): 1.5Ω(Typ.)
- FET ON resistance (5,6ch): 1.0Ω(Typ.)
- Operating temperature range: -20°C to +85°C

●Features

- Built-in 6 channels Driver block.
 - 1-4ch: Voltage control type H-bridge (Adaptable to STM 2systems)
 - 5ch: Voltage / Current control type H-bridge
 - 6ch: Current control type H-bridge
- Built-in 2 channels PI driving circuit
- Built-in 1 channels Waveforming circuit
- Built-in FLL digital servo circuit
- Built-in PLL circuit
- Built-in STM control circuit : Autonomous control(cache/updown mode), Clock IN control

●Package

UCSP75M3 3.10mm x 3.10mm x 0.85mm

●Applications

- Digital still cameras

●Typical Application Circuit

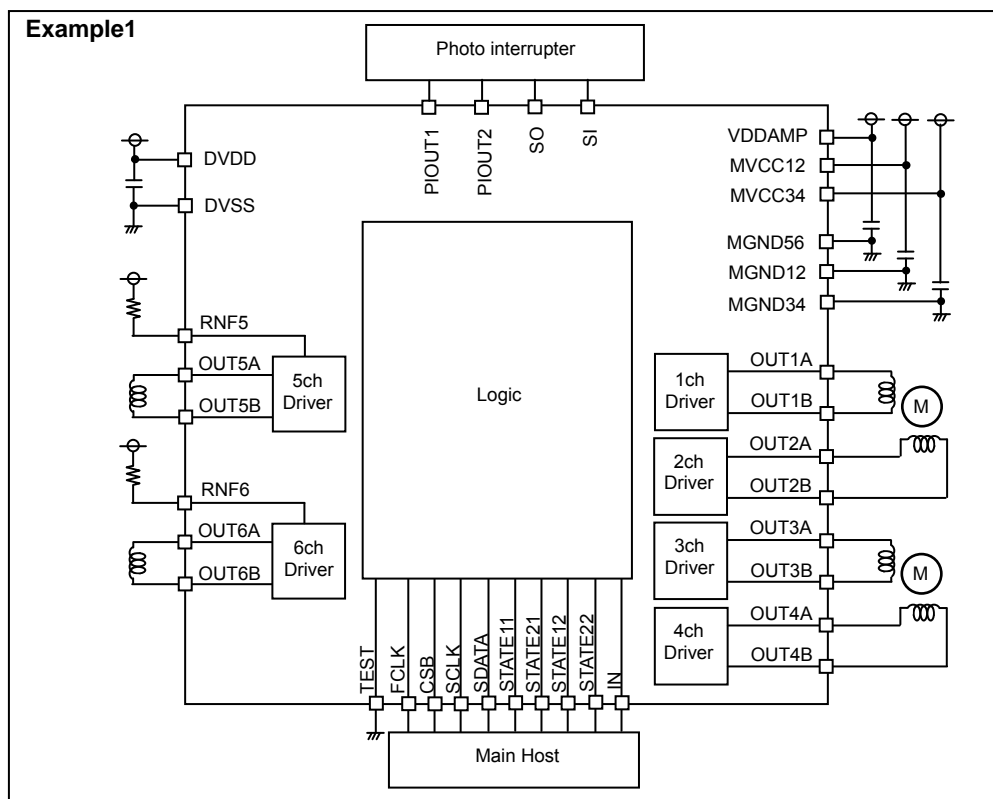

○Product structure : Silicon monolithic integrated circuit ○This product is not designed protection against radioactive rays

● Pin Configuration

(Bottom view)

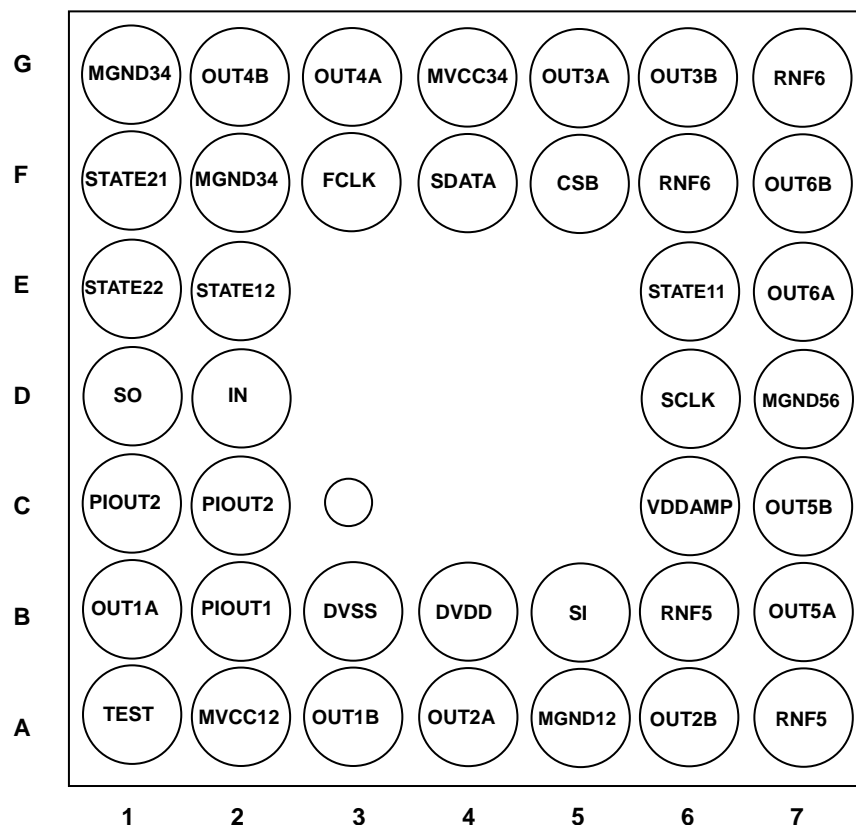

● Pin Description

Land Matrix No.	Pin name	Power supply	Function	Land Matrix No.	Pin name	Power supply	Function
B4	DVDD	-	Digital power supply	B1	OUT1A	MVCC12	1ch Driver A output
B3	DVSS	-	ground	A3	OUT1B	MVCC12	1ch Driver B output
F3	FCLK	DVDD	FCLK logic input	A4	OUT2A	MVCC12	2ch Driver A output
F5	CSB	DVDD	CSB logic input	A6	OUT2B	MVCC12	2ch Driver B output
D6	SCLK	DVDD	SCLK logic input	G4	MVCC34	-	3ch, 4ch Driver power supply
F4	SDATA	DVDD	SDATA logic input	G1,F2(*)	MGND34	-	3ch, 4ch Driver ground
D2	IN	DVDD	IN logic input	G5	OUT3A	MVCC34	3ch Driver A output
E6	STATE11	DVDD	STATE11 logic input/output	G6	OUT3B	MVCC34	3ch Driver B output
F1	STATE21	DVDD	STATE21 logic input/output	G3	OUT4A	MVCC34	4ch Driver A output
E2	STATE12	DVDD	STATE12 logic output	G2	OUT4B	MVCC34	4ch Driver B output
E1	STATE22	DVDD	STATE22 logic output	C6	VDDAMP	-	5ch, 6ch Power supply of current driver control
A1	TEST	DVDD	TEST logic input	D7	MGND56	-	5ch,6ch Driver ground
B2	PIOUT1	DVDD	PI driving output 1	A7,B6(*)	RNF5	-	5ch Driver power supply
C1,C2	PIOUT2	VDDAMP	PI driving output 2	B7	OUT5A	RNF5	5ch Driver A output
B5	SI	DVDD	Waveforming input	C7	OUT5B	RNF5	5ch Driver B output
D1	SO	DVDD	Waveforming output	F6,G7(*)	RNF6	-	6ch Driver power supply
A2	MVCC12	-	1ch, 2ch Driver power supply	E7	OUT6A	RNF6	6ch Driver A output
A5	MGND12	-	1ch, 2ch Driver ground	F7	OUT6B	RNF6	6ch Driver B output

(*) It is not possible to use corner pin only.(Corner pins are A7, G1, and G7.)

Please short A7-B6, F2-G1, F6-G7 and use it at the same time

●Block Diagram

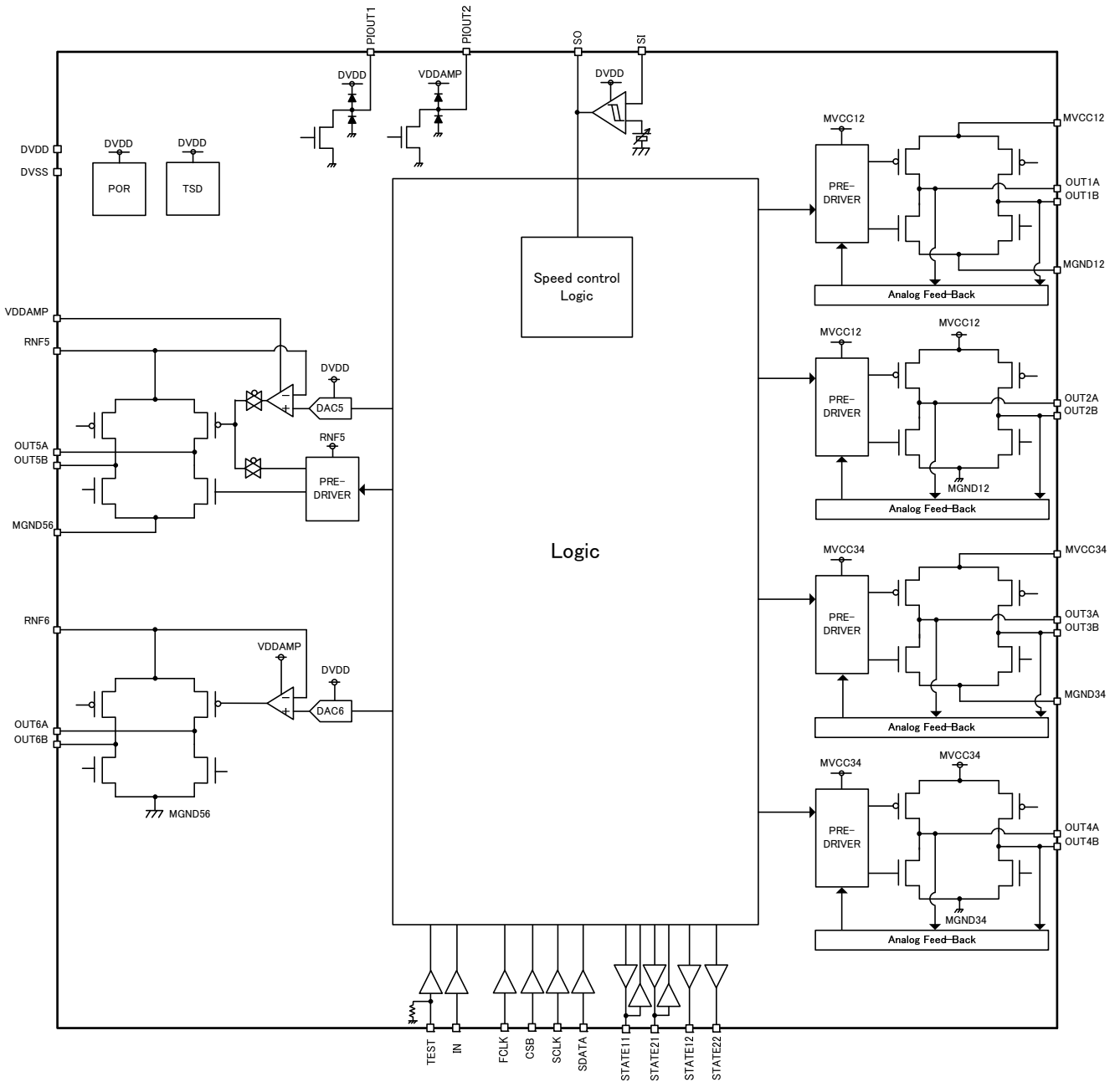

●Description of Blocks

Stepping motor driver (1-4ch Driver)

Built-in the stepping motor driver of PWM driving type.
1 stepping motor can be driven.
Built-in the voltage feedback circuit of D-class type

(1) Control

It corresponds both the Clock IN and the Autonomous control.

(i)Clock IN control

Set the registers for the stepping motor control.

The stepping motor is rotated at synchronized with the input clock to STATE pin.

It is possible to select the mode of stepping motor control from Micro-step, 1-2 phase excitation, 2 phase excitation and the number of edge for the electrical angle cycle from 4, 8, 32, 64, 128, 256, 512, 1024.



(ii)Autonomous control

The stepping motor is rotated by the setting of registers for the stepping motor control.

It is possible to select the mode of stepping motor control from Micro-step(1024 portion), 1-2 phase excitation, 2 phase excitation.

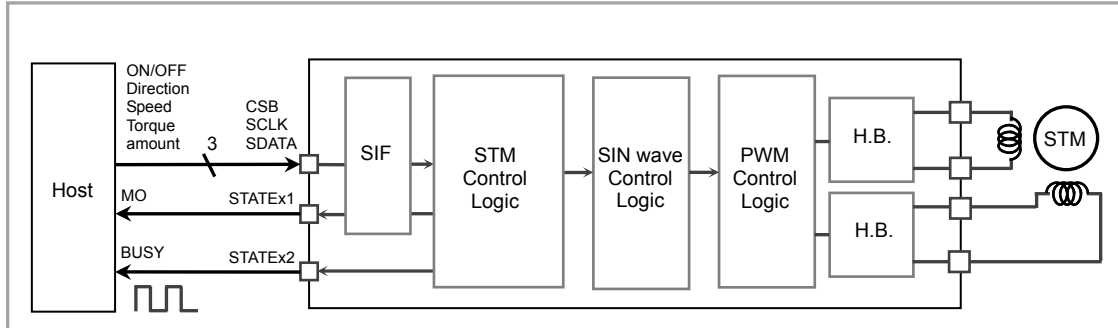

Cache method

Built-in Cache registers.

As Cache registers enable to set the subsequent process while the motor is in operation, it is possible to set the continuous operation.

Up down method

It is possible to set Up, Constant and Down operation before the motor is in operation.

●Description of Blocks

Voltage / Current driver (5ch Driver)

Built-in the voltage driver of PWM driving type / constant current driver.
 Built-in the digital FLL speed control logic for voltage driver.

(1) Control

(i)Register control

■Voltage driver(at the speed control = OFF)

The PWM driving is executed by the setting of register for the PWM duty ratio, direction and ON/OFF.

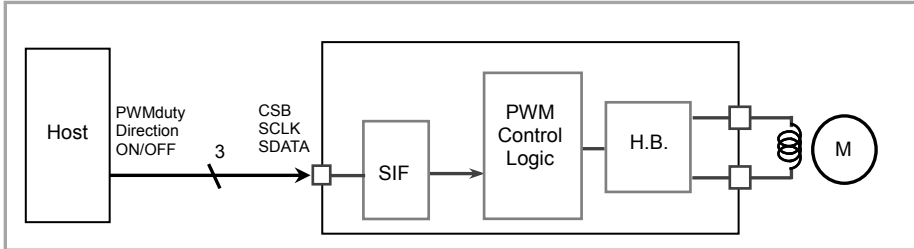

■Voltage driver(at the speed control = ON)

The speed control driving is executed by the setting of register for the target speed value, the direction, the coefficient value of PI filter and ON/OFF.

The motor speed is adjusted by the comparison of the target speed with the motor speed that detected from the signal of photo-interrupter

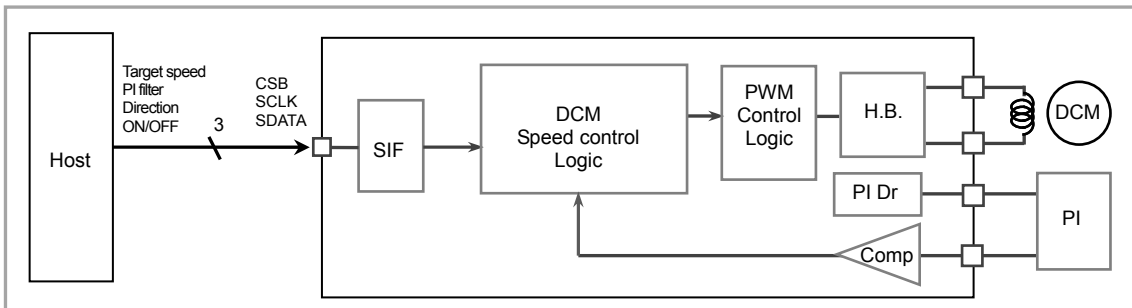

■Current driver

The constant current driving is executed by the setting of register for the output current value, the direction and ON/OFF.

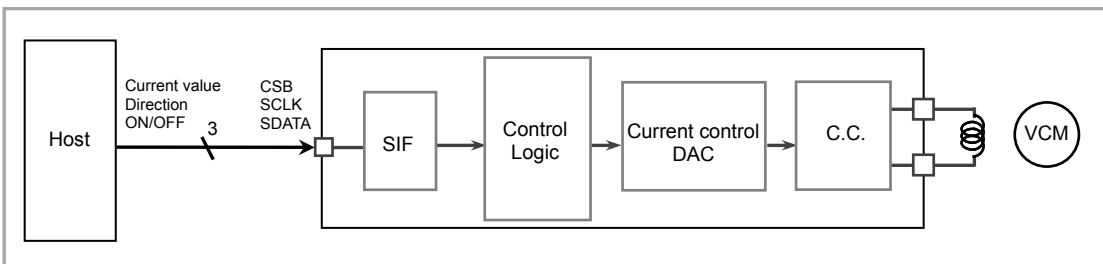

●Description of Blocks

(ii)External pin control

■Voltage driver(only at the speed control = OFF)

The PWM driving is executed by the setting of register for the PWM duty ratio and direction and the control of IN pin for the ON/OFF.

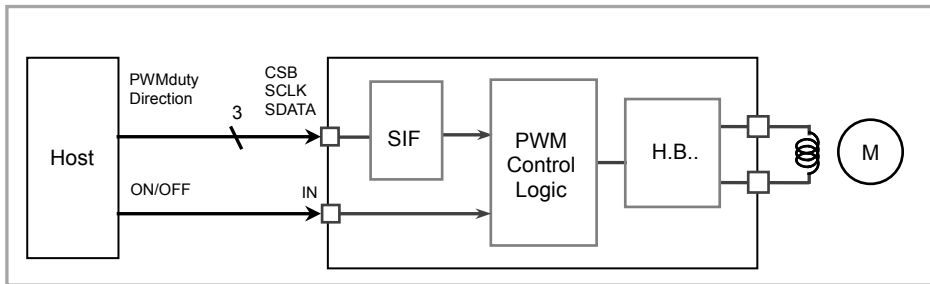

■Current driver

The constant current driving is executed by the setting of register for the output current value and the direction and the control of IN pin for ON/OFF.

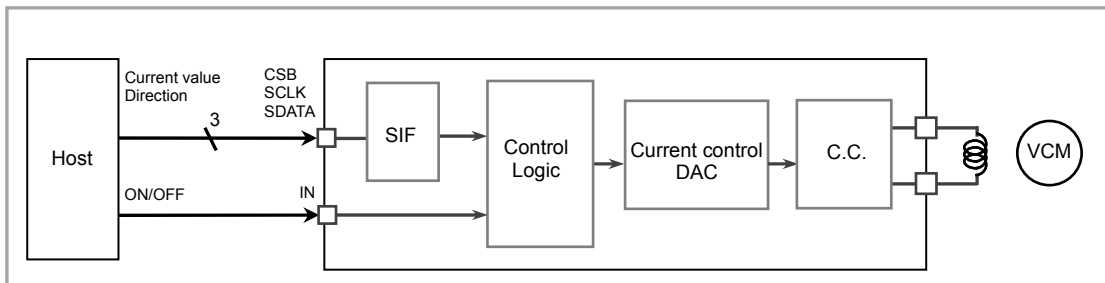

●Description of Blocks

Current driver (6ch driver)

Built-in the constant current driver.

The voltage of RNF pin and the external resistor(RRNF)are determined to the output current, and the internal high-precision amplifier(CMOS gate input)is exerted on the constant current control.

If any resistance component exists in the wirings of RNF pin and the external resistor(RRNF), the precision can be degraded.

To avoid that, pay utmost attention to the wirings.

(1) Control

(i)Register control

The constant current driving is executed by the setting of register for the output current value, the direction and ON/OFF.

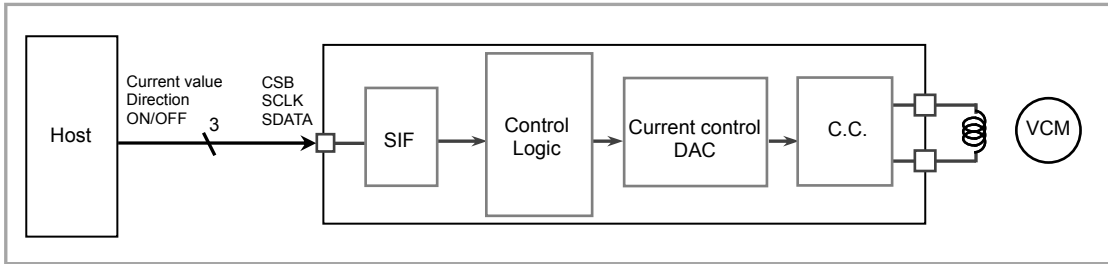

(ii)External pin control

The constant current driving is executed by the setting of register for the output current value and the direction and the control of IN pin for ON/OFF.

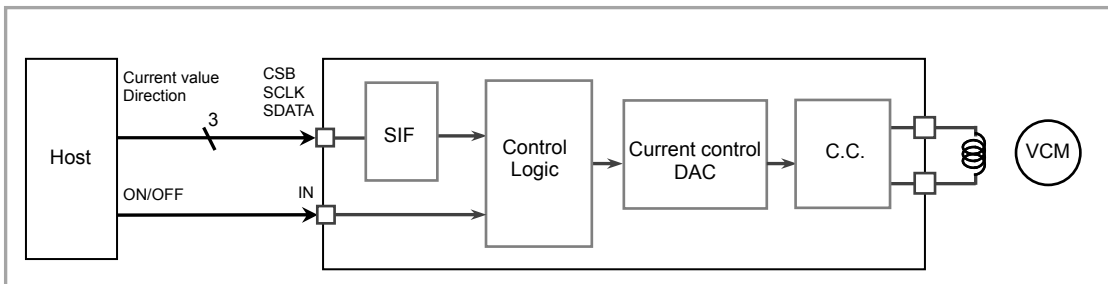

● Absolute Maximum Ratings (Ta=25°C)

Parameter	Symbol	Limits	Unit	Remark
Power supply voltage	DVDD	-0.3 to 4.5	V	
	MVCC	-0.3 to 7.0	V	MVCC12, MVCC34, VDDAMP
Input voltage	VIN	-0.3 to supply voltage+0.3	V	
Input/output current *1	IIN	±500	mA	MVCC12, MVCC34, RNF6
		±600	mA	RNF5
		+50	mA	PIOUT1
		+150	mA	PIOUT2
Storage temperature range	TSTG	-55 to 125	°C	
Operating temperature range	TOPE	-20 to 85	°C	
Permissible dissipation *2	PD	1050	mW	

*1 Must not exceed PD.

*2 To use at a temperature higher than Ta=25 °C, derate 10.5mW per 1 °C
(At mounting 50mm x 58mm x 1.75mm glass epoxy board.)

● Recommended Operating Rating (Ta=25°C)

Parameter	Symbol	Limits	Unit	Remark
Digital power supply voltage	DVDD	2.7 to 3.6	V	DVDD ≤ MVCC
Driver power supply voltage	MVCC	2.7 to 5.5	V	MVCC12, MVCC34, RNF5 RNF6, VDDAMP
Clock operating frequency	FCLK	1 to 28	MHz	Reference clock

●Electrical Characteristics

(Unless otherwise specified, Ta=25°C, DVDD=3.0V, MVCC=5.0V, DVSS=MGND=0.0V)

Parameter	Symbol	Limits			Unit	Condition
		MIN.	TYP.	MAX.		
<Current consumption>						
Quiescence (DVDD)	ISSD	-	20	50	uA	CMD_RS=0
(MVCC)	ISSM	-	0	10	uA	
Operation (DVDD)	IDDD	-	6	10	mA	CMD_RS=STB=CLK_EN=1 FCLK=24MHz (CLK_DIVx1.0mode) No load
<Logic block>						
Low-level input voltage	VIL	DVSS	-	0.3DVDD	V	
High-level input voltage	VIH	0.7DVDD	-	DVDD	V	
Low-level input current	IIL	0	-	10	uA	VIL=DVSS
High-level input current	IIH	0	-	10	uA	VIH=DVDD
Low-level output voltage	VOL	DVSS	-	0.2DVDD	V	IOL=1.0mA
High-level output voltage	VOH	0.8DVDD	-	DVDD	V	IOH=1.0mA
<PI driving circuit>						
Output voltage	PIVO	-	0.15	0.5	V	IIH=30mA
<Waveforming circuit>						
Detective voltage error	Vth	1.4	1.5	1.6	V	Vth setting : 10_0000
<Voltage driver block 1-4ch>						
ON-resistance	Ron	-	1.5	2.0	Ω	IO=±100mA (the sum of high and low sides)
OFF-leak current	IOZ	-10	0	10	uA	Output Hiz setting
Average voltage accuracy between different output pins	Vdiff	-5	-	+5	%	STM driver(1, 2ch) Vdiff setting : 010_1011
<Voltage/Current driver block 5ch>						
ON-resistance	Ron	-	1.0	1.5	Ω	IO=±100mA (the sum of high and low sides)
OFF-leak current	IOZ	-10	0	10	uA	Output Hiz setting
Output current	IO	190	200	210	mA	At the current driver mode DAC setting : 1000_0010 RRNF=1Ω
<Current driver block 6ch>						
ON-resistance	Ron	-	1.0	1.5	Ω	IO=±100mA (the sum of high and low sides)
OFF-leak current	IOZ	-10	0	10	uA	Output Hiz setting
Output current	IO	190	200	210	mA	DAC setting : 1000_0000 RRNF=1Ω

● Typical Performance Curves

(Unless otherwise specified, $T_a=25^{\circ}\text{C}$, $\text{DVDD}=3.0\text{V}$, $\text{MVCC}=5.0\text{V}$, $\text{DVSS}=\text{MGND}=0.0\text{V}$)

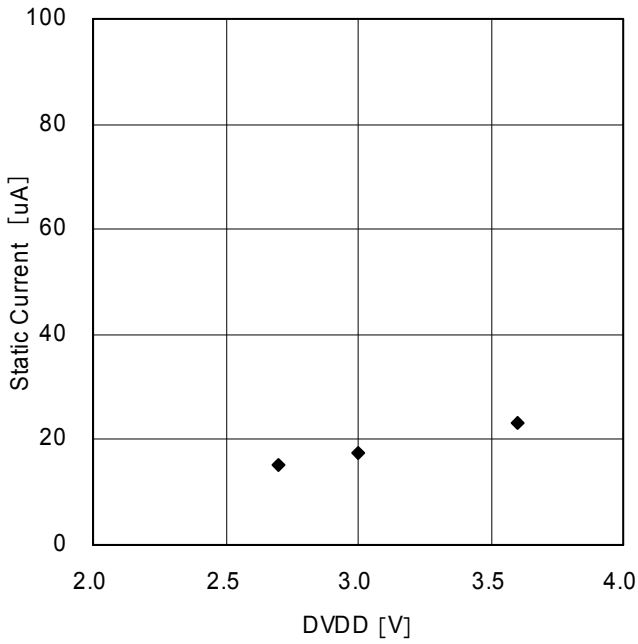

Figure 1. DVDD Static Current Voltage Dependency

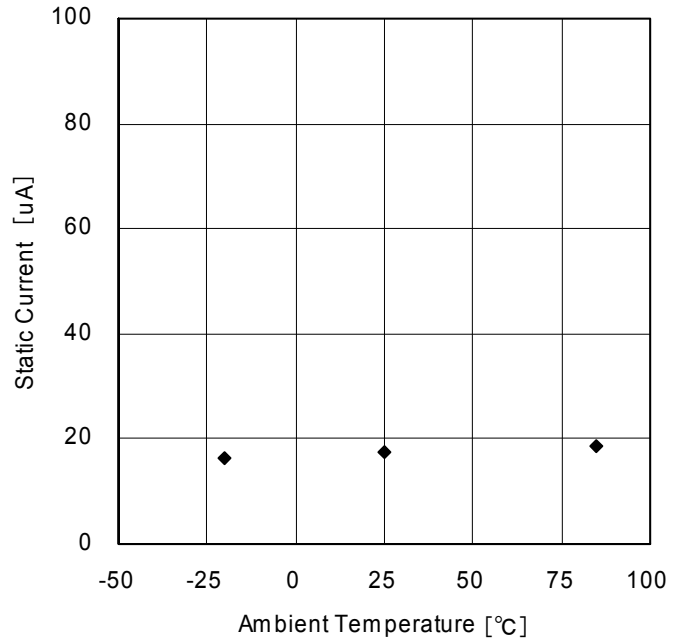

Figure 2. DVDD Static Current Temperature Dependency

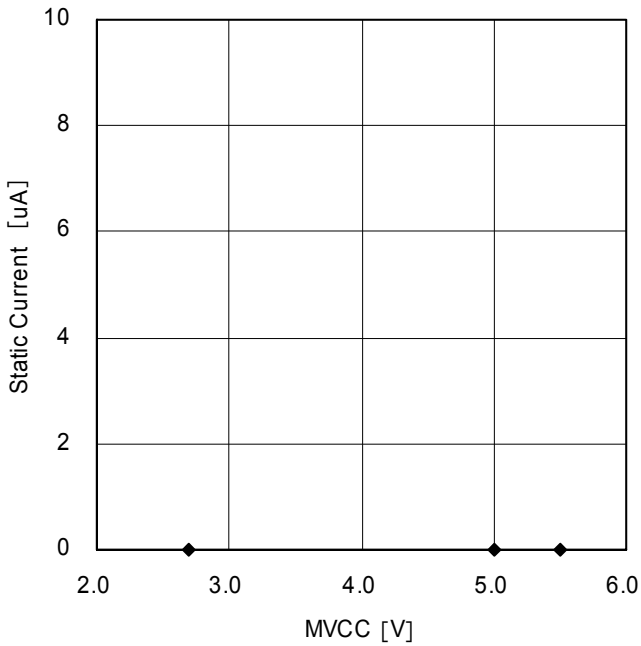

Figure 3. MVCC Static Current Voltage Dependency

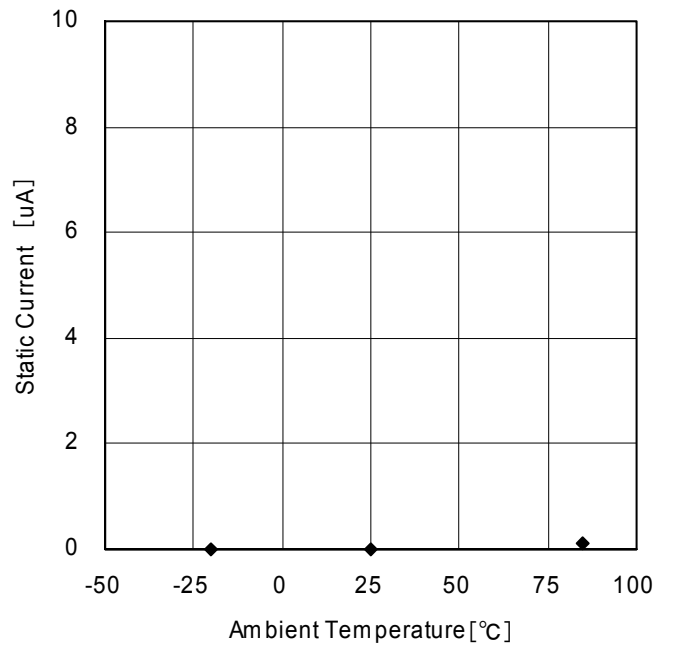

Figure 4. MVCC Static Current Temperature Dependency

● Typical Performance Curves

(Unless otherwise specified, $T_a=25^\circ\text{C}$, $DVDD=3.0\text{V}$, $MVCC=5.0\text{V}$, $DVSS=MGND=0.0\text{V}$)

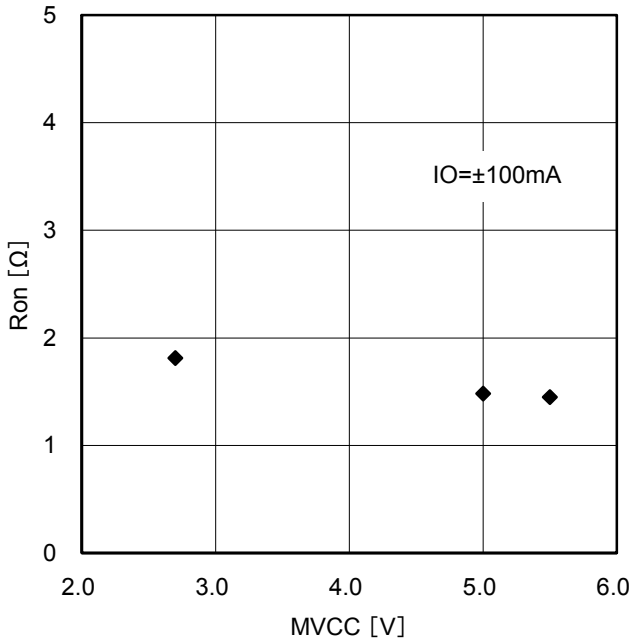

Figure 5. Output ON-Resistance
MVCC Dependency
(Voltage driver block)

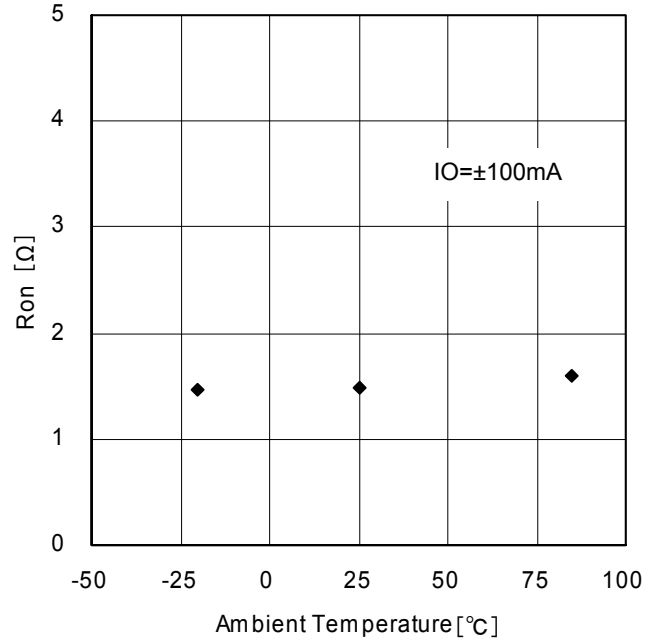

Figure 6. Output ON-Resistance
Temperature Dependency
(Voltage driver block)

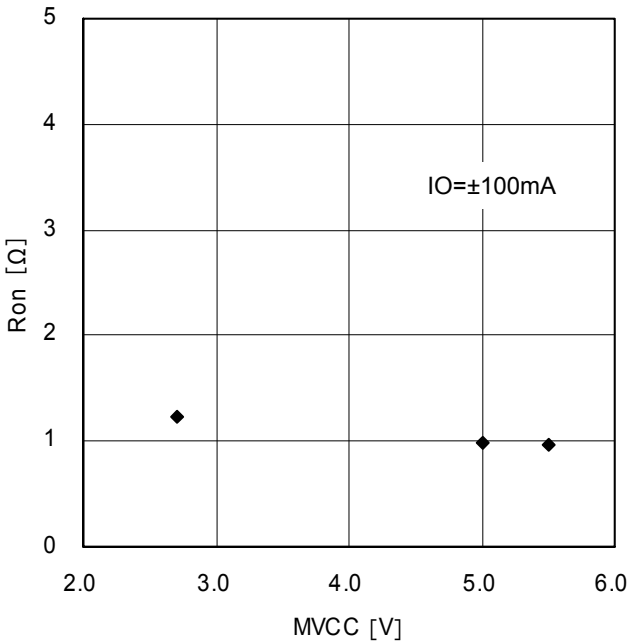

Figure 7. Output ON-Resistance
MVCC Dependency
(Current driver block)

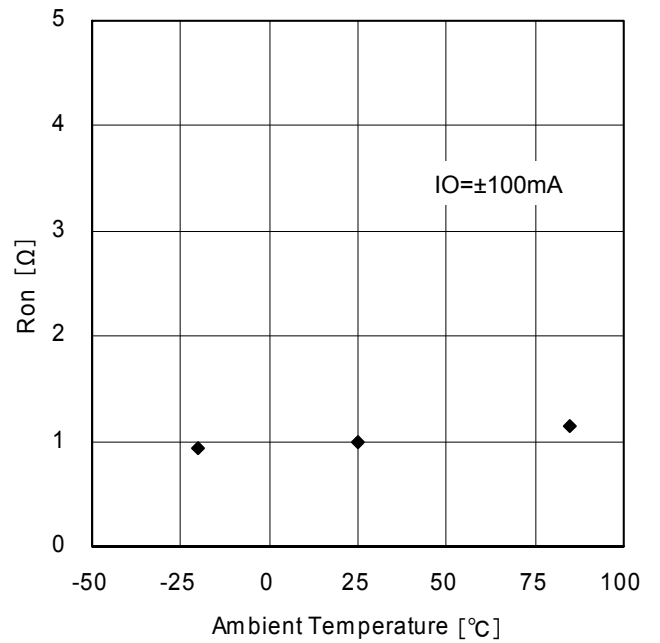

Figure 8. Output ON-Resistance
Temperature Dependency
(Current driver block)

● Typical Performance Curves

(Unless otherwise specified, $T_a=25^{\circ}\text{C}$, $\text{DVDD}=3.0\text{V}$, $\text{MVCC}=5.0\text{V}$, $\text{DVSS}=\text{MGND}=0.0\text{V}$)

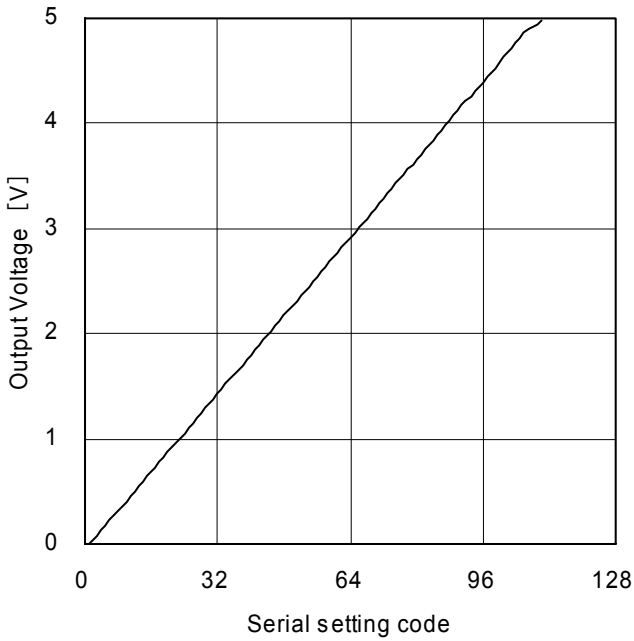

Figure 9. Average Voltage Accuracy between different output pins (Voltage driver block)

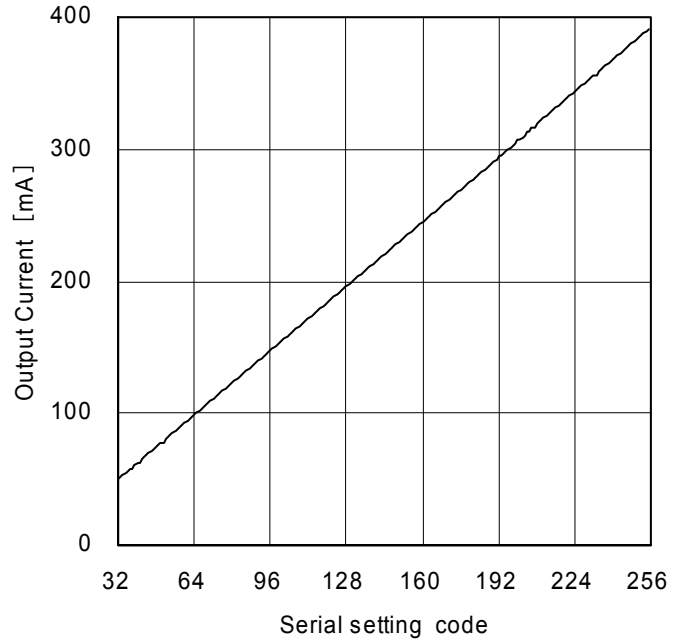

Figure 10. Output Current (Current driver block, $\text{RRNF} = 1.0\Omega$, $\text{RL} = 5.0\Omega$)

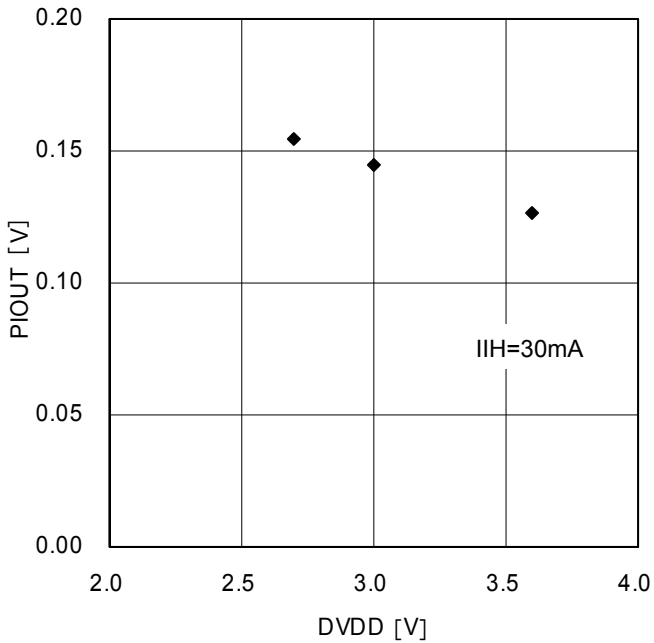

Figure 11. Output Voltage DVDD Dependency (PI driving circuit)

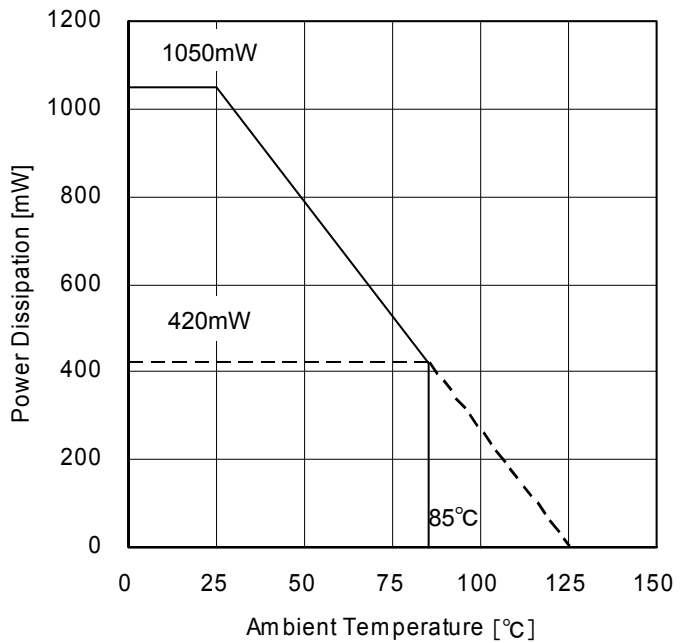
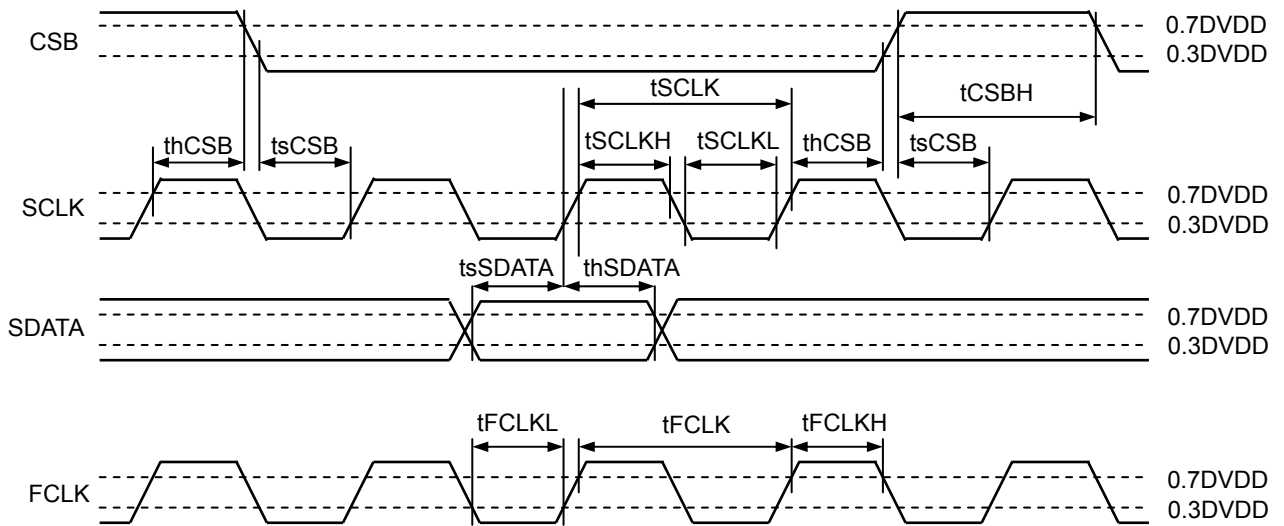

Figure 12. Power Dissipation Curve

●Timing Chart

(Unless otherwise specified, Ta=25°C, DVDD=3.0V)

Parameter	Symbol	Specification
SCLK input cycle	tSCLK	More than 100 nsec
SCLK L-level input time	tSCLKL	More than 50 nsec
SCLK H-level input time	tSCLKH	More than 50 nsec
SDATA setup time	tsSDATA	More than 50 nsec
SDATA hold time	thSDATA	More than 50 nsec
CSB H-level input time	tCSBH	More than 380 nsec
CSB setup time	tsCSB	More than 50 nsec
CSB hold time	thCSB	More than 50 nsec
FCLK input cycle	tFCLK	More than 36 nsec
FCLK L-level input time	tFCLKL	More than 18 nsec
FCLK H-level input time	tFCLKH	More than 18 nsec



(note1) FCLK is asynchronous with SCLK.
 (note2) Duty of FCLK, SCLK are free.

●Serial interface

Control commands are framed by 16-bit serial input (MSB first) and input through CSB, SCLK, and SDATA pins. 4 higher-order bits specify addresses, while the remaining 12 bits specify data. Data of every bit is input through SDATA pin, retrieved on the rising edges of SCLK, and written into registers on the rising edges of CSB.

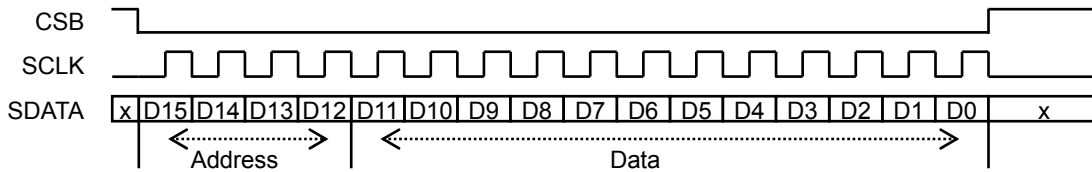

<Register map>

Address[3:0]				Data[11:0]												
15	14	13	12	11	10	9	8	7	6	5	4	3	2	1	0	
0	0	0	0	A_Mode[1:0]		A_SEL[2:0]		A_different_output_voltage[6:0]								
0	0	0	1	0	0	0	0	A_Cycle[5:0]						0	0	
				0	0	1	0	A_Cycle[13:6]								
				0	1	0	0	0	0	0	0	A_Start_POS[3:0]				
				0	1	1	0	A_BEXC	0	0	A_BSL	A_AEXC	0	0	A_AS_L	
1	1	1	0	0	0	0	A_POS[1:0]		0	A_UPDW_Stop	A_PS	A_Stop				
0	0	1	0	A_EN	A_RT	A_Pulse[9:0] / A_UPDW_Cycle[9:0]										
0	1	0	0	B_Mode[1:0]		B_SEL[2:0]		B_different_output_voltage[6:0]								
0	1	0	1	0	0	0	0	B_Cycle[5:0]						0	0	
				0	0	1	0	B_Cycle[13:6]								
				0	1	0	0	0	0	0	0	B_Start_POS[3:0]				
				0	1	1	0	B_BEXC	0	0	B_BSL	B_AEXC	0	0	B_AS_L	
				1	0	0	0	0	0	3_CHOP[1:0]		0	0	4_CHOP[1:0]		
				1	0	1	3_State_CTL[1:0]		3_PWM_Duty[6:0]							
				1	1	0	4_State_CTL[1:0]		4_PWM_Duty[6:0]							
1	1	1	0	0	0	0	B_POS[1:0]		0	B_UPDW_Stop	B_PS	B_Stop				
0	1	1	0	B_EN	B_RT	B_Pulse[9:0]/B_UPDW_Cycle[9:0]										
1	0	1	1	0	0	0	0	B_ANSEL	A_ANSEL	Edge	0	0	0	B_CTL	A_CTL	
				0	0	1	0	0	0	0	0	EXT_CTL[1:0]				
1	1	0	0	0	0	Chopping[1:0]		CacheM	0	5_Mode	CLK_EN	CLK_DIV[3:0]				
1	1	0	1	0	0	0	0	0	0	0	0	0	0	PI_CTL2	PI_CTL1	
				0	0	1	0	DET_SEL	0	SPEN[1:0]		0	0	0	0	
				0	1	1	0	TARSP[7:0]								
				0	1	1	1	0	PSP[2:0]			0	ISP[2:0]			
				1	0	0	0	0	0	0	0	SPC_Limit[3:0]				
1	1	1	0	0	0	0	0	5_IOUT[7:0]								
				0	0	1	0	0	5_PWM_Duty[6:0]							
				0	1	0	0	0	0	5_CHOP[1:0]		0	0	5_State_CTL[1:0]		
				0	1	1	0	0	0	0	0	6_State_CTL[2:0]				
				1	0	0	0	6_IOUT[7:0]								
				1	0	1	0	0	0	Waveform_Vth[5:0]						
				1	0	1	1	0	0	Waveform_Vth[5:0]						
1	1	0	0	0	0	0	0	STB	0	0	STM_RS	CMD_RS				
Addresses other than those above				Setting prohibited												

(Note 1) The notations A and B in the register map are corresponding to Ach and Bch respectively. Ach and Bch are defined by Ach:1.2ch driver output and the Bch:3.4ch driver output.
 (Note 2) After resetting (Power ON reset), the initial condition is saved in all registers.
 (Note 3) For Mode, different output voltage, Cycle, EN, and RT registers, data that are written immediately before gaining access to the Pulse register are enabled, and determined at the startup of CSB after the completion of gaining access to each Pulse register.(The Mode, different output voltage, Cycle, EN, RT, and Pulse registers contain Cache registers, but any registers other than those above do not contain with such registers.)

●Application Example

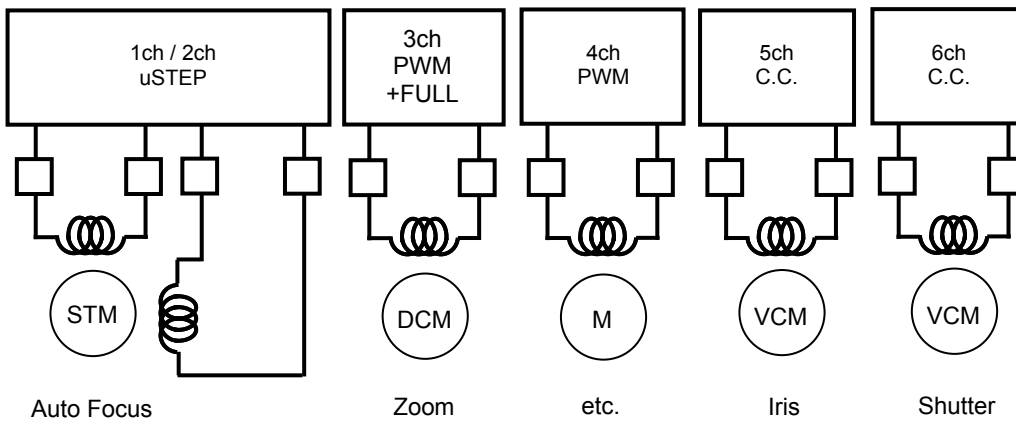
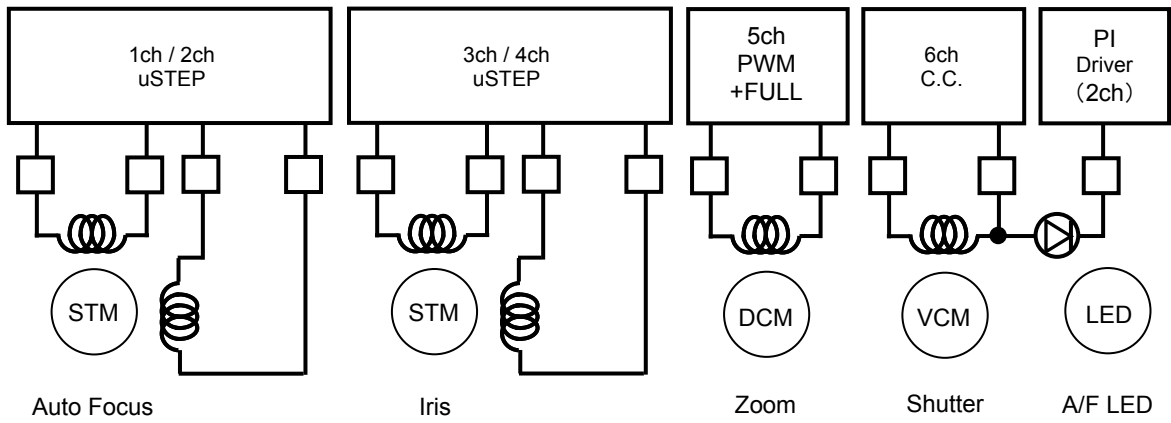
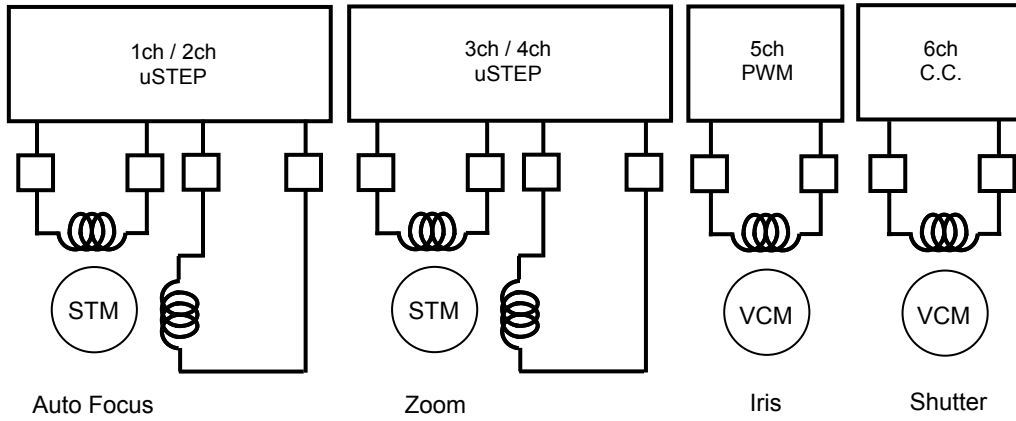

● I/O equivalence circuit

Pin	Equivalent circuit	Pin	Equivalent circuit
FCLK CSB SCLK SDATA IN		SI	
STATE11 STATE21		STATE12 STATE22 SO	
PIOUT1		PIOUT2	
OUT1A OUT1B OUT2A OUT2B		OUT3A OUT3B OUT4A OUT4B	
OUT5A OUT5B		OUT6A OUT6B	

● I/O equivalence circuit

Pin	Equivalent circuit
TEST (note1)	

(note1) Short TEST pin to DVSS.

●Operational Notes

- 1) Absolute maximum ratings
If applied voltage, operating temperature range, or other absolute maximum ratings are exceeded, the LSI may be damaged. Do not apply voltages or temperatures that exceed the absolute maximum ratings. If you expect that any voltage or temperature could be exceeding the absolute maximum ratings, take physical safety measures such as fuses to prevent any conditions exceeding the absolute maximum ratings from being applied to the LSI.
- 2) GND potential
Maintain the GND pin at the minimum voltage even under any operating conditions.
Actually check to be sure that none of the pins have voltage lower than that of GND pin, including transient phenomena.
- 3) Thermal design
With consideration given to the permissible dissipation under actual use conditions, perform thermal design so that adequate margins will be provided.
- 4) Short circuit between pins and malfunctions
To mount the LSI on a board, pay utmost attention to the orientation and displacement of the LSI. Faulty mounting to apply a voltage to the LSI may cause damage to the LSI. Furthermore, the LSI may also be damaged if any foreign matters enter between pins, between pin and power supply, or between pin and GND of the LSI.
- 5) Operation in strong magnetic field
Make a thorough evaluation on use of the LSI in a strong magnetic field. Not doing so may malfunction the LSI.
- 6) Power ON sequence
To turn ON the DVDD, be sure to reset at CMD_RS register.
- 7) Thermal shutdown
The temperature protection circuit (TSD circuit) is a circuit absolutely intended to shut down this IC from thermal runaway, not intended to protect or warrant the IC. Consequently, do not use the IC on the assumption that it will continuously use or operate after operating this circuit.
- 8) PI drive circuit
The output voltage of output PIOUT1 will not exceed the voltage of the power supply voltage DVDD.
The output voltage of output PIOUT2 will not exceed the voltage of the power supply voltage VDDAMP.

status of this document

The Japanese version of this document is formal specification. A customer may use this translation version only for a reference to help reading the formal version.

If there are any differences in translation version of this document formal version takes priority

●Ordering Information

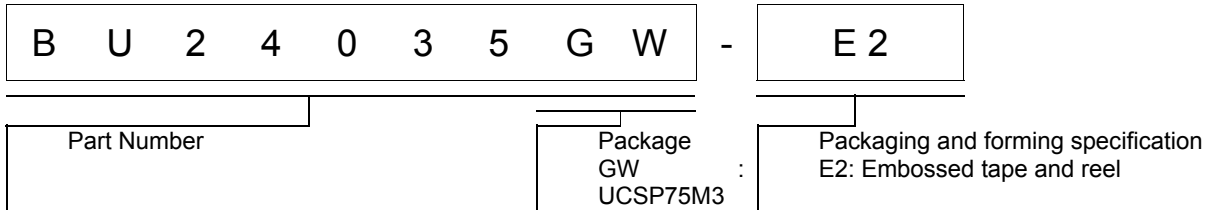

●Marking Diagram

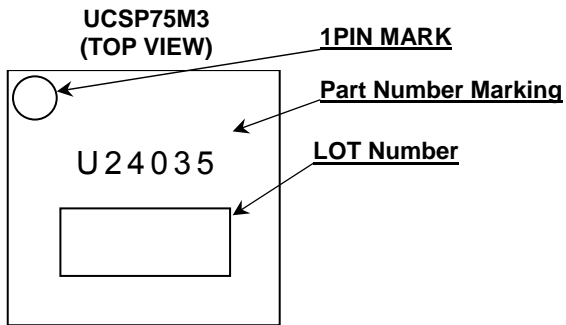

●Physical Dimension Tape and Reel Information

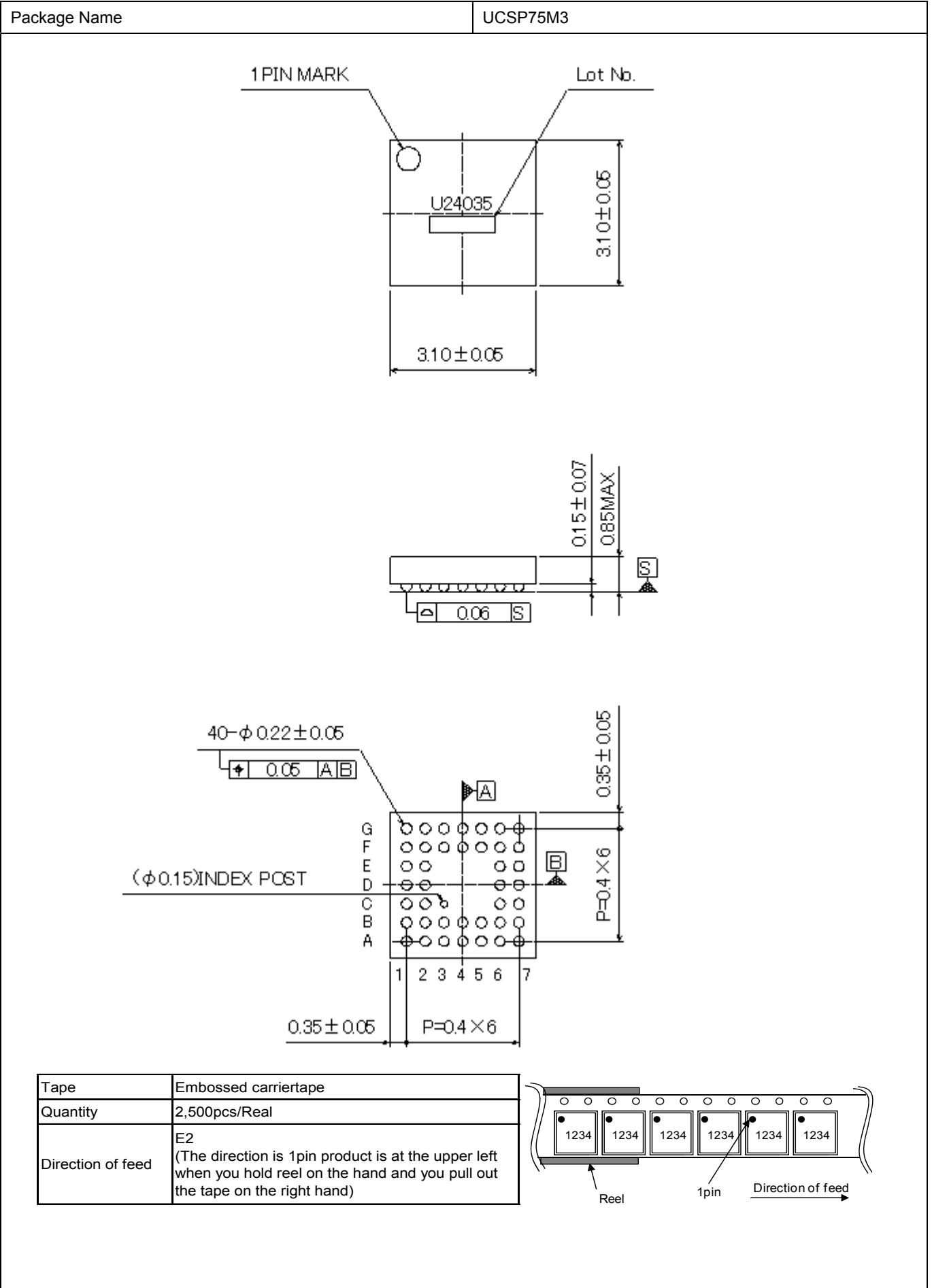

●Revision History

Date	Revision	Changes
26.Sep.2012	001	New Release

Notice

●General Precaution

- 1) Before you use our Products, you are requested to carefully read this document and fully understand its contents. ROHM shall not be in any way responsible or liable for failure, malfunction or accident arising from the use of any ROHM's Products against warning, caution or note contained in this document.
- 2) All information contained in this document is current as of the issuing date and subject to change without any prior notice. Before purchasing or using ROHM's Products, please confirm the latest information with a ROHM sales representative.

●Precaution on using ROHM Products

- 1) Our Products are designed and manufactured for application in ordinary electronic equipments (such as AV equipment, OA equipment, telecommunication equipment, home electronic appliances, amusement equipment, etc.). If you intend to use our Products in devices requiring extremely high reliability (such as medical equipment, transport equipment, traffic equipment, aircraft/spacecraft, nuclear power controllers, fuel controllers, car equipment including car accessories, safety devices, etc.) and whose malfunction or failure may cause loss of human life, bodily injury or serious damage to property ("Specific Applications"), please consult with the ROHM sales representative in advance. Unless otherwise agreed in writing by ROHM in advance, ROHM shall not be in any way responsible or liable for any damages, expenses or losses incurred by you or third parties arising from the use of any ROHM's Products for Specific Applications.
- 2) ROHM designs and manufactures its Products subject to strict quality control system. However, semiconductor products can fail or malfunction at a certain rate. Please be sure to implement, at your own responsibilities, adequate safety measures including but not limited to fail-safe design against the physical injury, damage to any property, which a failure or malfunction of our Products may cause. The following are examples of safety measures:
 - [a] Installation of protection circuits or other protective devices to improve system safety
 - [b] Installation of redundant circuits to reduce the impact of single or multiple circuit failure
- 3) Our Products are designed and manufactured for use under standard conditions and not under any special or extraordinary environments or conditions, as exemplified below. Accordingly, ROHM shall not be in any way responsible or liable for any damages, expenses or losses arising from the use of any ROHM's Products under any special or extraordinary environments or conditions. If you intend to use our Products under any special or extraordinary environments or conditions (as exemplified below), your independent verification and confirmation of product performance, reliability, etc. prior to use, must be necessary:
 - [a] Use of our Products in any types of liquid, including water, oils, chemicals, and organic solvents
 - [b] Use of our Products outdoors or in places where the Products are exposed to direct sunlight or dust
 - [c] Use of our Products in places where the Products are exposed to sea wind or corrosive gases, including Cl₂, H₂S, NH₃, SO₂, and NO₂
 - [d] Use of our Products in places where the Products are exposed to static electricity or electromagnetic waves
 - [e] Use of our Products in proximity to heat-producing components, plastic cords, or other flammable items
 - [f] Sealing or coating our Products with resin or other coating materials
 - [g] Use of our Products without cleaning residue of flux (even if you use no-clean type fluxes, cleaning residue of flux is recommended); or Washing our Products by using water or water-soluble cleaning agents for cleaning residue after soldering
 - [h] Use of the Products in places subject to dew condensation
- 4) The Products are not subject to radiation-proof design.
- 5) Please verify and confirm characteristics of the final or mounted products in using the Products.
- 6) In particular, if a transient load (a large amount of load applied in a short period of time, such as pulse) is applied, confirmation of performance characteristics after on-board mounting is strongly recommended. Avoid applying power exceeding normal rated power; exceeding the power rating under steady-state loading condition may negatively affect product performance and reliability.
- 7) De-rate Power Dissipation (Pd) depending on Ambient temperature (Ta). When used in sealed area, confirm the actual ambient temperature.
- 8) Confirm that operation temperature is within the specified range described in the product specification.
- 9) ROHM shall not be in any way responsible or liable for failure induced under deviant condition from what is defined in this document.

●Precaution for Mounting / Circuit board design

- 1) When a highly active halogenous (chlorine, bromine, etc.) flux is used, the residue of flux may negatively affect product performance and reliability.
- 2) In principle, the reflow soldering method must be used; if flow soldering method is preferred, please consult with the ROHM representative in advance.

For details, please refer to ROHM Mounting specification

●Precautions Regarding Application Examples and External Circuits

- 1) If change is made to the constant of an external circuit, please allow a sufficient margin considering variations of the characteristics of the Products and external components, including transient characteristics, as well as static characteristics.
- 2) You agree that application notes, reference designs, and associated data and information contained in this document are presented only as guidance for Products use. Therefore, in case you use such information, you are solely responsible for it and you must exercise your own independent verification and judgment in the use of such information contained in this document. ROHM shall not be in any way responsible or liable for any damages, expenses or losses incurred by you or third parties arising from the use of such information.

●Precaution for Electrostatic

This Product is electrostatic sensitive product, which may be damaged due to electrostatic discharge. Please take proper caution in your manufacturing process and storage so that voltage exceeding the Products maximum rating will not be applied to Products. Please take special care under dry condition (e.g. Grounding of human body / equipment / solder iron, isolation from charged objects, setting of Ionizer, friction prevention and temperature / humidity control).

●Precaution for Storage / Transportation

- 1) Product performance and soldered connections may deteriorate if the Products are stored in the places where:
 - [a] the Products are exposed to sea winds or corrosive gases, including Cl₂, H₂S, NH₃, SO₂, and NO₂
 - [b] the temperature or humidity exceeds those recommended by ROHM
 - [c] the Products are exposed to direct sunshine or condensation
 - [d] the Products are exposed to high Electrostatic
- 2) Even under ROHM recommended storage condition, solderability of products out of recommended storage time period may be degraded. It is strongly recommended to confirm solderability before using Products of which storage time is exceeding the recommended storage time period.
- 3) Store / transport cartons in the correct direction, which is indicated on a carton with a symbol. Otherwise bent leads may occur due to excessive stress applied when dropping of a carton.
- 4) Use Products within the specified time after opening a humidity barrier bag. Baking is required before using Products of which storage time is exceeding the recommended storage time period.

●Precaution for Product Label

QR code printed on ROHM Products label is for ROHM's internal use only.

●Precaution for Disposition

When disposing Products please dispose them properly using an authorized industry waste company.

●Precaution for Foreign Exchange and Foreign Trade act

Since our Products might fall under controlled goods prescribed by the applicable foreign exchange and foreign trade act, please consult with ROHM representative in case of export.

●Precaution Regarding Intellectual Property Rights

- 1) All information and data including but not limited to application example contained in this document is for reference only. ROHM does not warrant that foregoing information or data will not infringe any intellectual property rights or any other rights of any third party regarding such information or data. ROHM shall not be in any way responsible or liable for infringement of any intellectual property rights or other damages arising from use of such information or data.:
- 2) No license, expressly or implied, is granted hereby under any intellectual property rights or other rights of ROHM or any third parties with respect to the information contained in this document.

●Other Precaution

- 1) The information contained in this document is provided on an "as is" basis and ROHM does not warrant that all information contained in this document is accurate and/or error-free. ROHM shall not be in any way responsible or liable for any damages, expenses or losses incurred by you or third parties resulting from inaccuracy or errors of or concerning such information.
- 2) This document may not be reprinted or reproduced, in whole or in part, without prior written consent of ROHM.
- 3) The Products may not be disassembled, converted, modified, reproduced or otherwise changed without prior written consent of ROHM.
- 4) In no event shall you use in any way whatsoever the Products and the related technical information contained in the Products or this document for any military purposes, including but not limited to, the development of mass-destruction weapons.
- 5) The proper names of companies or products described in this document are trademarks or registered trademarks of ROHM, its affiliated companies or third parties.