

DC Brushless Fan Motor Driver

Standard Single-phase Full wave Fan motor driver

BD6961F
●Description

This is the summary of application for BD6961F. BD6961F can drive FAN motor silently by BTL soft switching, and it can control rotational speed by PWM signal.

●Features

- BTL soft switching drive
- PWM speed control
- Quick start function
- Lock protection and auto restart (without external capacitor)
- Rotating speed pulse signal (FG) output

●Application

- PC, PC peripheral component (Power supply, VGA card, case FAN etc.)
- BD player, Projector etc.

●Package(s)
 SOP8

 W(Typ.) x D(Typ.) x H(Max.)
 5.00mm x 6.20mm x 1.71mm

SOP8

●Absolute maximum ratings

Parameter	Symbol	Limit	Unit
Supply voltage	Vcc	15	V
Power dissipation	Pd	780*	mW
Operating temperature	Topr	-40 to +105	°C
Storage temperature	Tstg	-55 to +150	°C
Output voltage	Vomax	15	V
Output current	Iomax	1000**	mA
FG signal output voltage	Vfg	15	V
FG signal output current	Ifg	10	mA
Junction temperature	Tjmax	150	°C

* Reduce by 6.24mW/°C over Ta=25°C(70.0mm×70.0mm×1.6mm glass epoxy board)

** This value is not to exceed Pd

●Operating conditions

Parameter	Symbol	Limit	Unit
Operating supply voltage range	Vcc	3.3 to 14	V
Hall input voltage range	Vh	0 to Vcc/3	V

○Product structure : Silicon monolithic integrated circuit ○This product is not designed protection against radioactive rays

www.rohm.com

© 2012 ROHM Co., Ltd. All rights reserved.

TSZ22111 · 14 · 001

●Electrical characteristics (Unless otherwise specified Ta=25°C,Vcc=12V)

Parameter	Symbol	Limits			Unit	Conditions	Characteristics
		Min.	Typ.	Max.			
Circuit current 1	Icc1	1	3	5	mA	PWM=GND	Fig.1
Circuit current 2	Icc2	2	5	8	mA	PWM=OPEN	Fig.2
Input offset voltage	Vhofs	-	-	±6	mV		-
FG hysteresis voltage	Vhys	±5	±10	±15	mV		Fig.3
PWM input H level	Vpwmh	2.5	-	Vcc+0.3	V		-
PWM input L level	Vpwml	-0.3	-	0.8	V		-
PWM input current	Ipwmh	11	22	33	μA	PWM=5.0V	Fig.4
	Ipwml	-42	-28	-14	μA	PWM=GND	Fig.4
Input frequency	Fpwm	0.02	-	50	kHz		-
Output voltage	Vo	-	0.4	0.6	V	I _o =300mA Upper and Lower total	Fig.5 to 8
Input-output Gain	Gio	45	48	51	dB		-
FG low voltage	Vfgl	-	-	0.4	V	I _{fg} =5mA	Fig.9
FG leak current	I _{fgl}	-	-	20	μA	V _{fg} =15V	Fig.10
Lock detection ON time	Ton	0.35	0.50	0.65	s		Fig.11
Lock detection OFF time	Toff	3.5	5.0	6.5	s		Fig.12

●Truth table

H+	H-	PWM	OUT1	OUT2	FG
H	L	H(OPEN)	H	L	L(Output Tr : ON)
L	H	H(OPEN)	L	H	H(Output Tr : OFF)
H	L	L	L	L	L(Output Tr : ON)
L	H	L	L	L	H(Output Tr : OFF)

●Reference Data

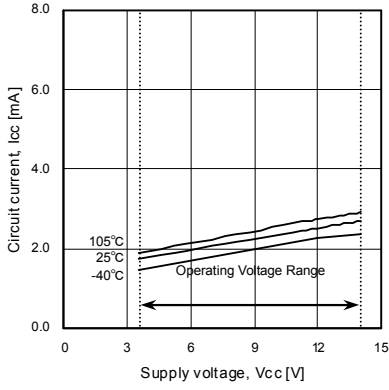

Fig.1 Circuit current 1

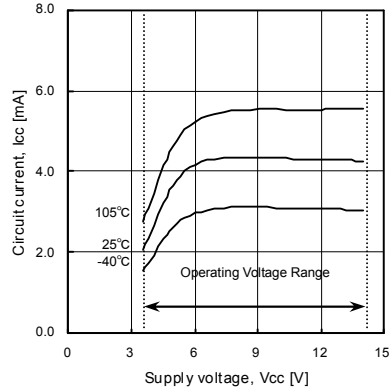

Fig.2 Circuit current 2

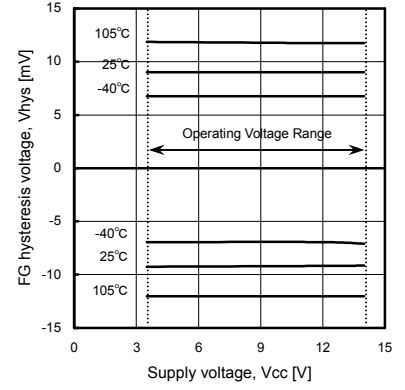

Fig.3 FG hysteresis voltage

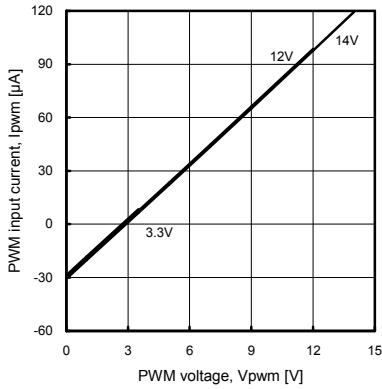

Fig.4 PWM input current

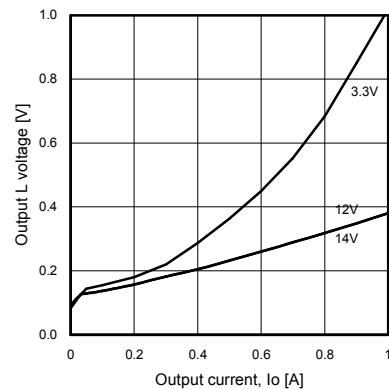

Fig.5 Output L voltage (Voltage characteristics)

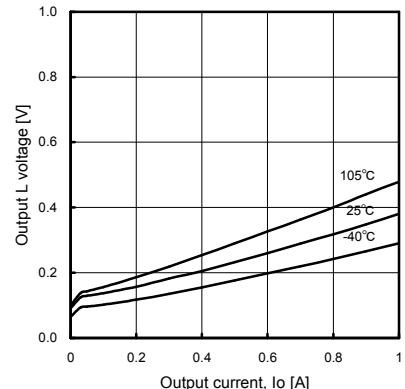

Fig.6 Output L voltage (Temperature characteristics)

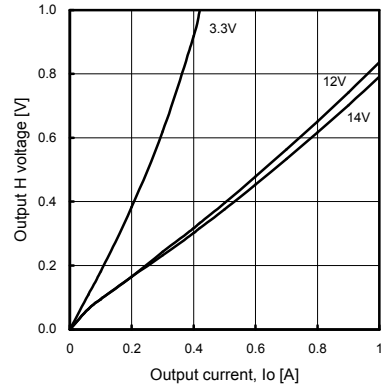

Fig.7 Output H voltage (Voltage characteristics)

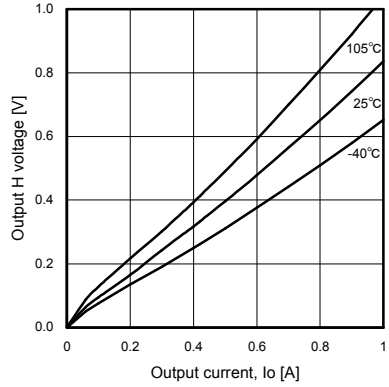

Fig.8 Output H voltage (Temperature characteristics)

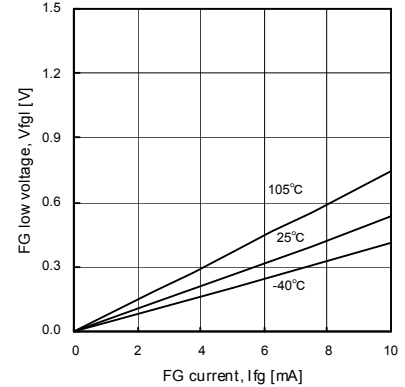

Fig.9 FG L voltage

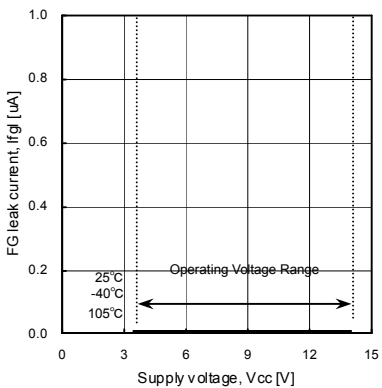

Fig.10 FG leak current

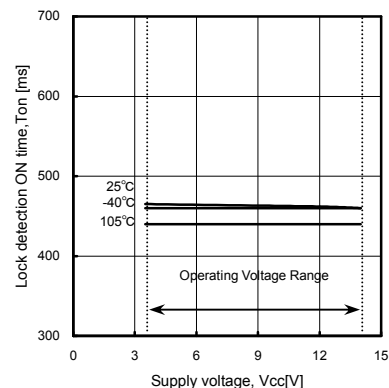

Fig.11 Lock detection ON time

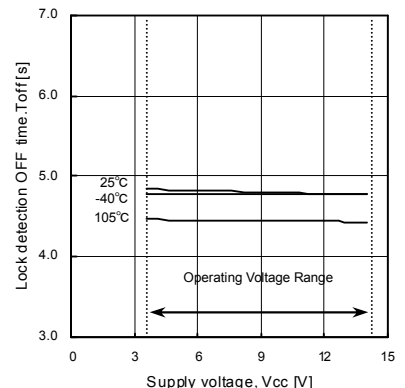
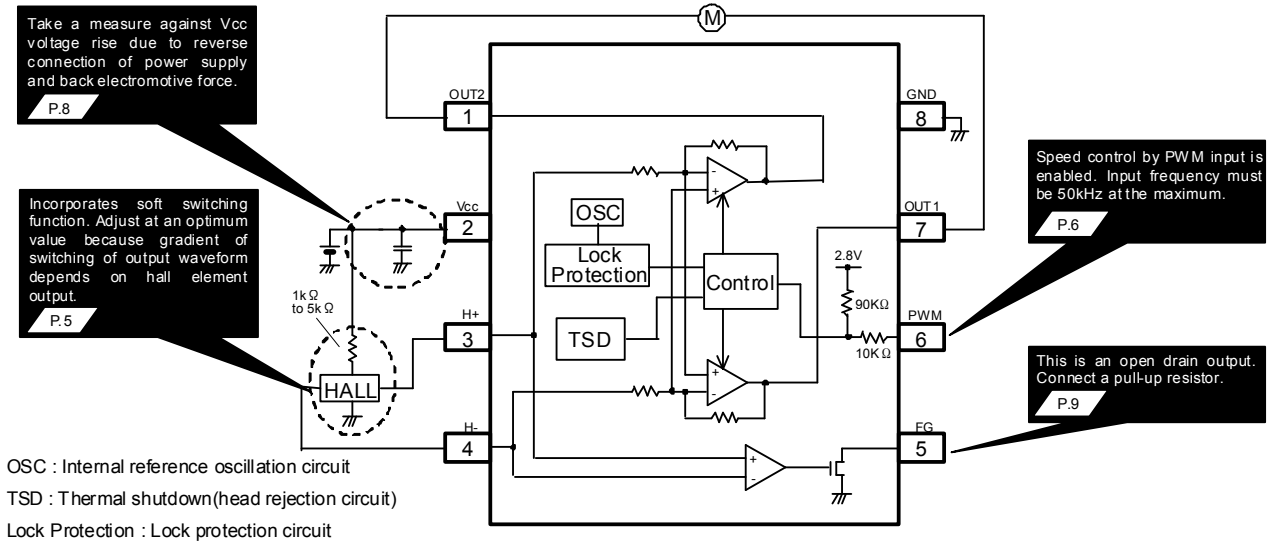

Fig.12 Lock detection OFF time

●Block diagram, application circuit, and pin assignment (Constant etc are for reference)



PIN No.	Terminal name	Function
1	OUT2	Motor output terminal 2
2	Vcc	Power supply terminal
3	H+	Hall input terminal+
4	H-	Hall input terminal-
5	FG	Rotating speed pulse signal output terminal
6	PWM	PWM signal input terminal
7	OUT1	Motor output terminal 1
8	GND	GND terminal

●Description of operations

1) Lock protection and automatic restart circuit

Motor rotation is detected by hall signal, and lock detection ON time (Ton) and lock detection OFF time (Toff) are set by IC internal counter. External part (C or R) is not required. Timing chart is shown in Fig.13.

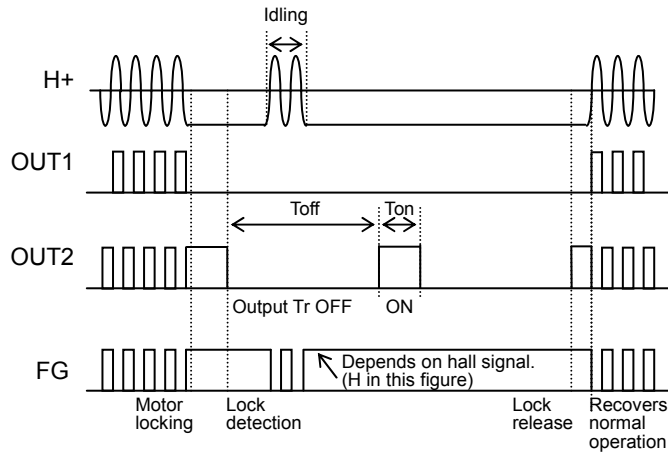

Fig.13 Lock protection timing chart

2) Soft switching function (silent drive setting)

Input signal to hall amplifier is amplified to produce an output signal. When the hall element output signal is small, the gradient of switching of output waveform is gentle; When it is large, the gradient of switching of output waveform is steep. Enter an appropriate hall element output to IC where output waveform swings sufficiently.

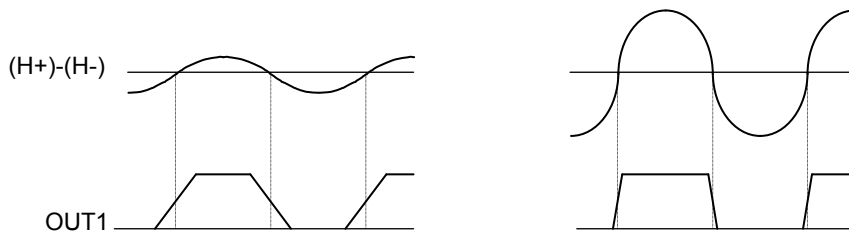

Fig.14 Relation between hall element output amplitude and output waveform

3) Hall input setting

Hall input voltage range is shown in operating conditions.

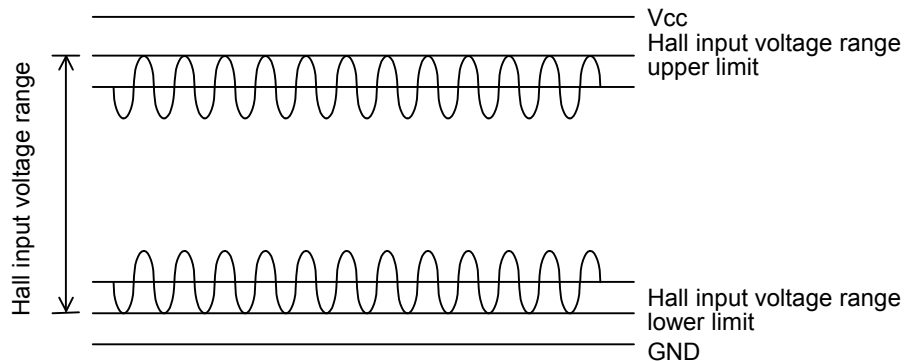

Fig.15 Hall input voltage range

Adjust the value of hall element bias resistor R1 in Fig.16 so that the input voltage of a hall amplifier is input in "hall input voltage range" including signal amplitude.

○Reducing the noise of hall signal

Hall element may be affected by Vcc noise depending on the wiring pattern of board. In this case, place a capacitor like C1 in Fig.16. In addition, when wiring from the hall element output to IC hall input is long, noise may be loaded on wiring. In this case, place a capacitor like C2 in Fig.16.

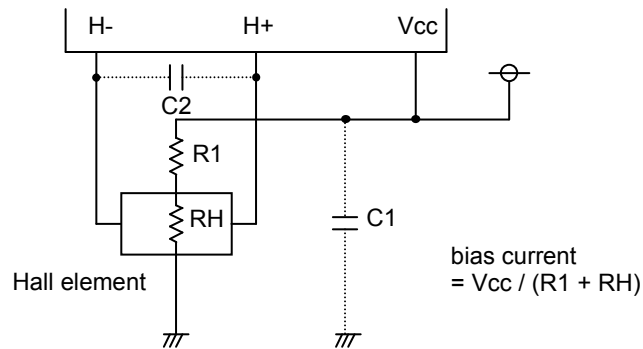

Fig.16 Application near of hall signal

4) PWM input

Rotation speed of motor can be changed by controlling ON/OFF of the upper output depending on duty of the signal input to PWM terminal.

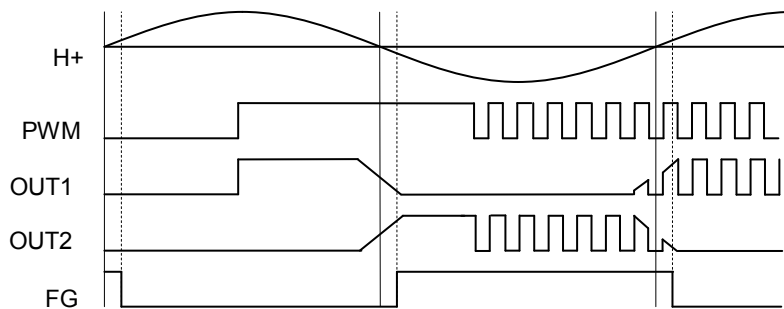

Fig.17 Timing chart in PWM control

When the voltage input to PWM terminal applies H logic : normal operation
L logic : H side output is off

When PWM terminal is open, H logic is applied. PWM terminal has hysteresis of 100mV (Typ.).

*If H logic is applied to PWM terminal before Vcc voltage is applied to IC, current flows to Vcc terminal through ESD protection diode inside PWM terminal, resulting in malfunction may possibly occur. When Vcc voltage is not apply to IC, do not apply voltage to PWM terminal.

5) Quick start, stand-by function

The function can start motor at once regardless of the detection time of lock protection function when the PWM signal is input. Lock protection function is turned off when the time of PWM = L has elapsed more than 66.5 ms in order to disable lock protection function when the motor is stopped by PWM signal.

When H level duty of PWM input signal is close to 0%, lock protection function does not work at an input frequency slower than 15Hz, therefore enter a frequency faster than 20Hz.

●Equivalent circuit

1) Hall input terminal

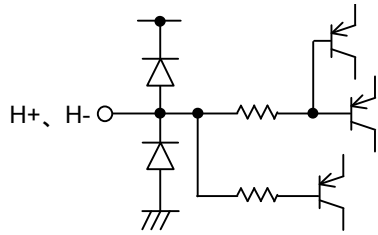

2) Motor output terminal

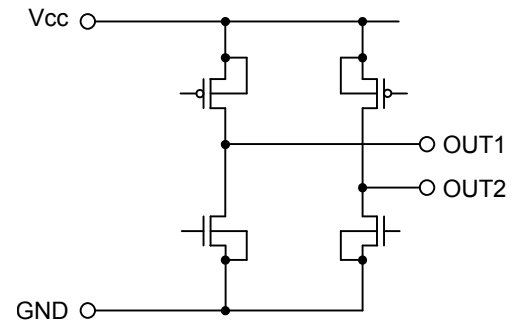

3) PWM signal input terminal

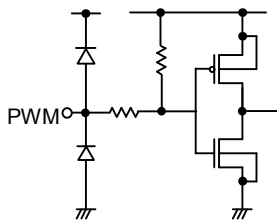

4) FG output terminal

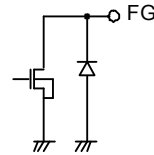

● Safety measure

1) Reverse connection protection diode

Reverse connection of power results in IC destruction as shown in Fig.18. When reverse connection is possible, reverse connection destruction preventive diode must be added between power supply and Vcc.

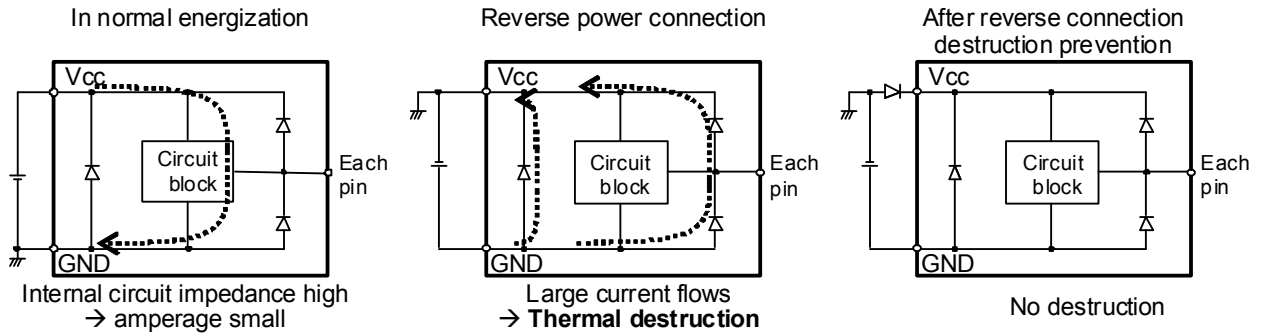

Fig.18 Flow of current when power is connected reversely

2) Measure against Vcc voltage rise by back electromotive force

Back electromotive force (Back EMF) generates regenerative current to power supply. However, when reverse connection protection diode is connected, Vcc voltage rises because the diode prevents current flow to power supply.

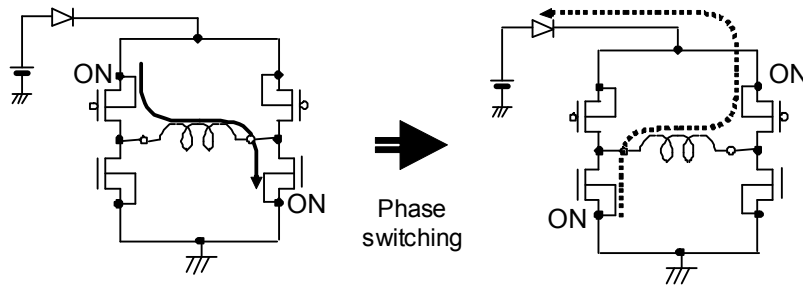

Fig.19 Vcc voltage rise by back electromotive force

When the absolute maximum rated voltage may be exceeded due to voltage rise by back electromotive force, place (A) Capacitor or (B) Zener diode between Vcc and GND. If necessary, add both (C).

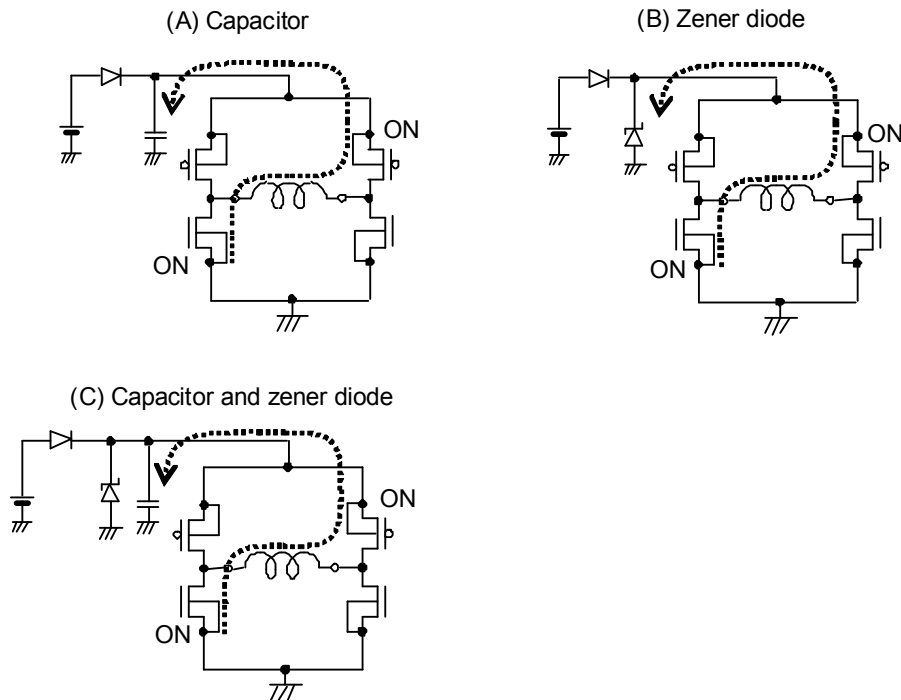

Fig.20 Measure against Vcc voltage rise

3) Problem of GND line PWM switching

Do not perform PWM switching of GND line because the potential of GND terminal cannot be kept at the minimum.

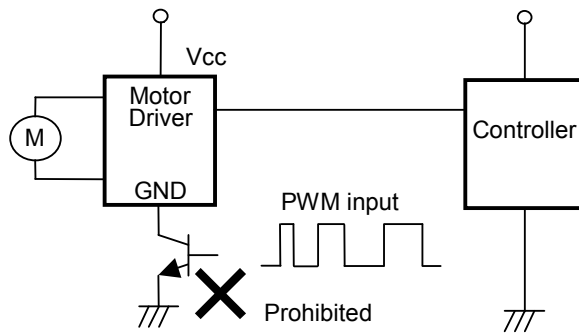

Fig.21 GND Line PWM switching prohibited

4) FG output

FG output is an open drain and requires pull-up resistor.

The IC can be protected by adding resistor R1. An excess of absolute maximum rating, when FG output terminal is directly connected to power supply, could damage the IC.

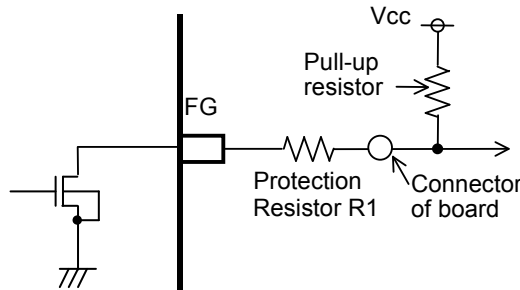
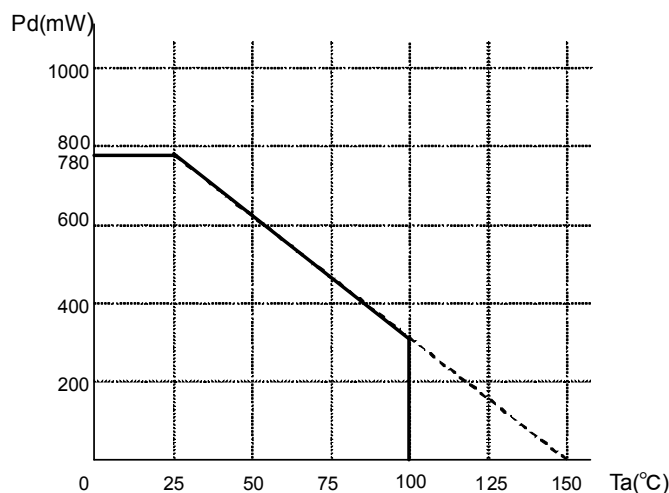

Fig.22 Protection of FG terminal

● Thermal derating curve

Thermal derating curve indicates power that can be consumed by IC with reference to ambient temperature. Power that can be consumed by IC begins to attenuate at certain ambient temperature. This gradient is determined by thermal resistance θ_{ja} .

Thermal resistance θ_{ja} depends on chip size, power consumption, package ambient temperature, packaging condition, wind velocity, etc., even when the same package is used. Thermal derating curve indicates a reference value measured at a specified condition. Fig.23 shows a thermal derating curve (Value when mounting FR4 glass epoxy board 70 [mm] x 70 [mm] x 1.6 [mm] (copper foil area below 3 [%]))



* Reduce by 6.24 mW/°C over 25°C.
(70.0mm×70.0mm×1.6mm glass epoxy board)

Fig.23 Thermal derating curve

●Notes for use

- 1) Absolute maximum ratings
Devices may be destroyed when supply voltage or operating temperature exceeds the absolute maximum ratings. Because the cause of this damage cannot be identified as a short circuit or an open circuit, if any over rated values will expect to exceed the absolute maximum ratings, consider adding circuit protection devices, such as fuses.
- 2) Connecting the power supply connector backward
Connecting of the power supply in reverse polarity can damage IC. Take precautions when connecting the power supply lines. An external direction diode can be added.
- 3) Power supply line
Back electromotive force causes regenerated current to power supply line, therefore take a measure such as placing a capacitor between power supply and GND for routing regenerated current. And fully ensure that the capacitor characteristics have no problem before determine a capacitor value. (when applying electrolytic capacitors, capacitance characteristic values are reduced at low temperatures)
- 4) GND potential
It is possible that the motor output terminal may deflect below GND terminal because of influence by back electromotive force of motor. The potential of GND terminal must be minimum potential in all operating conditions, except that the levels of the motor outputs terminals are under GND level by the back electromotive force of the motor coil. Also ensure that all terminals except GND and motor output terminals do not fall below GND voltage including transient characteristics. Malfunction may possibly occur depending on use condition, environment, and property of individual motor. Please make fully confirmation that no problem is found on operation of IC.
- 5) Thermal design
Use a thermal design that allows for a sufficient margin in light of the power dissipation(Pd) in actual operating conditions.
- 6) Inter-pin shorts and mounting errors
Use caution when positioning the IC for mounting on printed circuit boards. The IC may be damaged if there is any connection error or if pins are shorted together.
- 7) Actions in strong electromagnetic field
Use caution when using the IC in the presence of a strong electromagnetic field as doing so may cause the IC to malfunction.
- 8) ASO
When using the IC, set the output transistor so that it does not exceed absolute maximum ratings or ASO.
- 9) Thermal shut down circuit
The IC incorporates a built-in thermal shutdown circuit (TSD circuit). Operation temperature is 175°C (typ.) and has a hysteresis width of 25°C (typ.). When IC chip temperature rises and TSD circuit works, the output terminal becomes an open state. TSD circuit is designed only to shut the IC off to prevent thermal runaway. It is not designed to protect the IC or guarantee its operation. Do not continue to use the IC after operation this circuit or use the IC in an environment where the operation of this circuit is assumed.
- 10) Testing on application boards
When testing the IC on an application board, connecting a capacitor to a pin with low impedance subjects the IC to stress. Always discharge capacitors after each process or step. Always turn the IC's power supply off before connecting it to or removing it from a jig or fixture during the inspection process. Ground the IC during assembly steps as an antistatic measure. Use similar precaution when transporting or storing the IC.
- 11) GND wiring pattern
When using both small signal and large current GND patterns, it is recommended to isolate the two ground patterns, placing a single ground point at the ground potential of application so that the pattern wiring resistance and voltage variations caused by large currents do not cause variations in the small signal ground voltage. Be careful not to change the GND wiring pattern of any external components, either.
- 12) Capacitor between output and GND
When a large capacitor is connected between output and GND, if Vcc is shorted with 0V or GND for some cause, it is possible that the current charged in the capacitor may flow into the output resulting in destruction. Keep the capacitor between output and GND below 100uF.
- 13) IC terminal input
When Vcc voltage is not applied to IC, do not apply voltage to each input terminal. When voltage above Vcc or below GND is applied to the input terminal, parasitic element is actuated due to the structure of IC. Operation of parasitic element causes mutual interference between circuits, resulting in malfunction as well as destruction in the last. Do not use in a manner where parasitic element is actuated.
- 14) In use
We are sure that the example of application circuit is preferable, but please check the character further more in application to a part which requires high precision. In using the unit with external circuit constant changed, consider the variation of externally equipped parts and our IC including not only static character but also transient character and allow sufficient margin in determining.

Status of this document

The Japanese version of this document is formal specification. A customer may use this translation version only for a reference to help reading the formal version.

If there are any differences in translation version of this document formal version takes priority

●Physical Dimension

SOP8

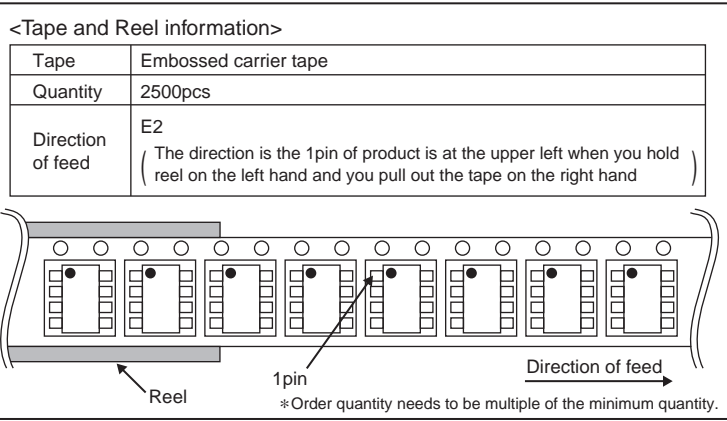
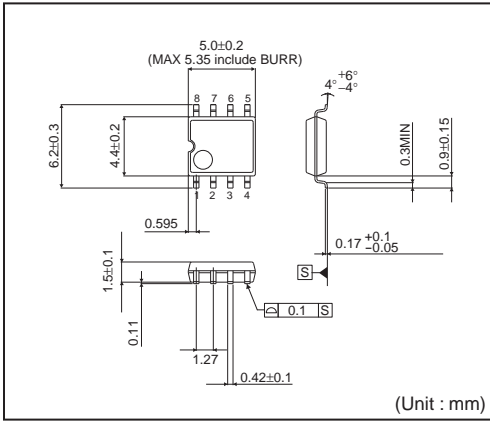

●Marking Diagram

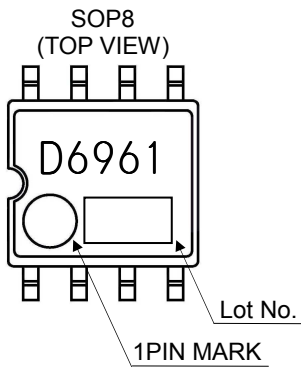

Notice

●General Precaution

- 1) Before you use our Products, you are requested to carefully read this document and fully understand its contents. ROHM shall not be in any way responsible or liable for failure, malfunction or accident arising from the use of any ROHM's Products against warning, caution or note contained in this document.
- 2) All information contained in this document is current as of the issuing date and subject to change without any prior notice. Before purchasing or using ROHM's Products, please confirm the latest information with a ROHM sales representative.

●Precaution on using ROHM Products

- 1) Our Products are designed and manufactured for application in ordinary electronic equipments (such as AV equipment, OA equipment, telecommunication equipment, home electronic appliances, amusement equipment, etc.). If you intend to use our Products in devices requiring extremely high reliability (such as medical equipment, transport equipment, traffic equipment, aircraft/spacecraft, nuclear power controllers, fuel controllers, car equipment including car accessories, safety devices, etc.) and whose malfunction or failure may cause loss of human life, bodily injury or serious damage to property ("Specific Applications"), please consult with the ROHM sales representative in advance. Unless otherwise agreed in writing by ROHM in advance, ROHM shall not be in any way responsible or liable for any damages, expenses or losses incurred by you or third parties arising from the use of any ROHM's Products for Specific Applications.
- 2) ROHM designs and manufactures its Products subject to strict quality control system. However, semiconductor products can fail or malfunction at a certain rate. Please be sure to implement, at your own responsibilities, adequate safety measures including but not limited to fail-safe design against the physical injury, damage to any property, which a failure or malfunction of our Products may cause. The following are examples of safety measures:
 - [a] Installation of protection circuits or other protective devices to improve system safety
 - [b] Installation of redundant circuits to reduce the impact of single or multiple circuit failure
- 3) Our Products are designed and manufactured for use under standard conditions and not under any special or extraordinary environments or conditions, as exemplified below. Accordingly, ROHM shall not be in any way responsible or liable for any damages, expenses or losses arising from the use of any ROHM's Products under any special or extraordinary environments or conditions. If you intend to use our Products under any special or extraordinary environments or conditions (as exemplified below), your independent verification and confirmation of product performance, reliability, etc. prior to use, must be necessary:
 - [a] Use of our Products in any types of liquid, including water, oils, chemicals, and organic solvents
 - [b] Use of our Products outdoors or in places where the Products are exposed to direct sunlight or dust
 - [c] Use of our Products in places where the Products are exposed to sea wind or corrosive gases, including Cl₂, H₂S, NH₃, SO₂, and NO₂
 - [d] Use of our Products in places where the Products are exposed to static electricity or electromagnetic waves
 - [e] Use of our Products in proximity to heat-producing components, plastic cords, or other flammable items
 - [f] Sealing or coating our Products with resin or other coating materials
 - [g] Use of our Products without cleaning residue of flux (even if you use no-clean type fluxes, cleaning residue of flux is recommended); or Washing our Products by using water or water-soluble cleaning agents for cleaning residue after soldering
 - [h] Use of the Products in places subject to dew condensation
- 4) The Products are not subject to radiation-proof design.
- 5) Please verify and confirm characteristics of the final or mounted products in using the Products.
- 6) In particular, if a transient load (a large amount of load applied in a short period of time, such as pulse) is applied, confirmation of performance characteristics after on-board mounting is strongly recommended. Avoid applying power exceeding normal rated power; exceeding the power rating under steady-state loading condition may negatively affect product performance and reliability.
- 7) De-rate Power Dissipation (Pd) depending on Ambient temperature (Ta). When used in sealed area, confirm the actual ambient temperature.
- 8) Confirm that operation temperature is within the specified range described in the product specification.
- 9) ROHM shall not be in any way responsible or liable for failure induced under deviant condition from what is defined in this document.

● **Precaution for Mounting / Circuit board design**

- 1) When a highly active halogenous (chlorine, bromine, etc.) flux is used, the residue of flux may negatively affect product performance and reliability.
- 2) In principle, the reflow soldering method must be used; if flow soldering method is preferred, please consult with the ROHM representative in advance.

For details, please refer to ROHM Mounting specification

● **Precautions Regarding Application Examples and External Circuits**

- 1) If change is made to the constant of an external circuit, please allow a sufficient margin considering variations of the characteristics of the Products and external components, including transient characteristics, as well as static characteristics.
- 2) You agree that application notes, reference designs, and associated data and information contained in this document are presented only as guidance for Products use. Therefore, in case you use such information, you are solely responsible for it and you must exercise your own independent verification and judgment in the use of such information contained in this document. ROHM shall not be in any way responsible or liable for any damages, expenses or losses incurred by you or third parties arising from the use of such information.

● **Precaution for Electrostatic**

This Product is electrostatic sensitive product, which may be damaged due to electrostatic discharge. Please take proper caution in your manufacturing process and storage so that voltage exceeding the Products maximum rating will not be applied to Products. Please take special care under dry condition (e.g. Grounding of human body / equipment / solder iron, isolation from charged objects, setting of Ionizer, friction prevention and temperature / humidity control).

● **Precaution for Storage / Transportation**

- 1) Product performance and soldered connections may deteriorate if the Products are stored in the places where:
 - [a] the Products are exposed to sea winds or corrosive gases, including Cl₂, H₂S, NH₃, SO₂, and NO₂
 - [b] the temperature or humidity exceeds those recommended by ROHM
 - [c] the Products are exposed to direct sunshine or condensation
 - [d] the Products are exposed to high Electrostatic
- 2) Even under ROHM recommended storage condition, solderability of products out of recommended storage time period may be degraded. It is strongly recommended to confirm solderability before using Products of which storage time is exceeding the recommended storage time period.
- 3) Store / transport cartons in the correct direction, which is indicated on a carton with a symbol. Otherwise bent leads may occur due to excessive stress applied when dropping of a carton.
- 4) Use Products within the specified time after opening a humidity barrier bag. Baking is required before using Products of which storage time is exceeding the recommended storage time period.

● **Precaution for Product Label**

QR code printed on ROHM Products label is for ROHM's internal use only.

● **Precaution for Disposition**

When disposing Products please dispose them properly using an authorized industry waste company.

● **Precaution for Foreign Exchange and Foreign Trade act**

Since our Products might fall under controlled goods prescribed by the applicable foreign exchange and foreign trade act, please consult with ROHM representative in case of export.

● **Precaution Regarding Intellectual Property Rights**

- 1) All information and data including but not limited to application example contained in this document is for reference only. ROHM does not warrant that foregoing information or data will not infringe any intellectual property rights or any other rights of any third party regarding such information or data. ROHM shall not be in any way responsible or liable for infringement of any intellectual property rights or other damages arising from use of such information or data.:
- 2) No license, expressly or implied, is granted hereby under any intellectual property rights or other rights of ROHM or any third parties with respect to the information contained in this document.

●Other Precaution

- 1) The information contained in this document is provided on an "as is" basis and ROHM does not warrant that all information contained in this document is accurate and/or error-free. ROHM shall not be in any way responsible or liable for any damages, expenses or losses incurred by you or third parties resulting from inaccuracy or errors of or concerning such information.
- 2) This document may not be reprinted or reproduced, in whole or in part, without prior written consent of ROHM.
- 3) The Products may not be disassembled, converted, modified, reproduced or otherwise changed without prior written consent of ROHM.
- 4) In no event shall you use in any way whatsoever the Products and the related technical information contained in the Products or this document for any military purposes, including but not limited to, the development of mass-destruction weapons.
- 5) The proper names of companies or products described in this document are trademarks or registered trademarks of ROHM, its affiliated companies or third parties.