

Motor/Actuator Drivers for DC Brush Motor series

Automotive 1ch

60V Max, H-bridge Drivers



BD16910EFV-M

●Description

The acceptable reversal motor driver for output 1.0A automotive 1 motor is a motor driver that can set to four modes (normal rotation, reverse rotation, the stop (idling), and the brake) according to two input logic.

It is possible to contribute to high reliability, energy-saving, and the lowering the cost of the set because a high resisting pressure (maximum ratings 60V) and the low ON resistance and small packages have been achieved.

●Feature

- 1 Built-in 1.0A DMOS H bridge output 1 circuit
- 2 input control (stand by, normal rotation, reverse rotation, brake)
- Low stand by current
- Built-in output reversely electromotive pressure absorption diode
- Built-in overcurrent protection circuit (detection and timer)
- Built-in overpower-supply voltage output OFF function
- Built-in thermal shutdown (TSD)
- Built-in protection state output (PO) terminal

●Key Specifications

- Power supply voltage 8 to 16V
- Operating temperature range -40 to 110°C
- Output current 1.0A
- Output ON resistance1 2.25Ω(TYP)

●Package(s)

HTSSOP-B20

6.5mm×6.4mm×1.0mm



●Applications

For automotive (Body equipment, air conditioner, and door mirror, etc)

●Typical Application Circuits

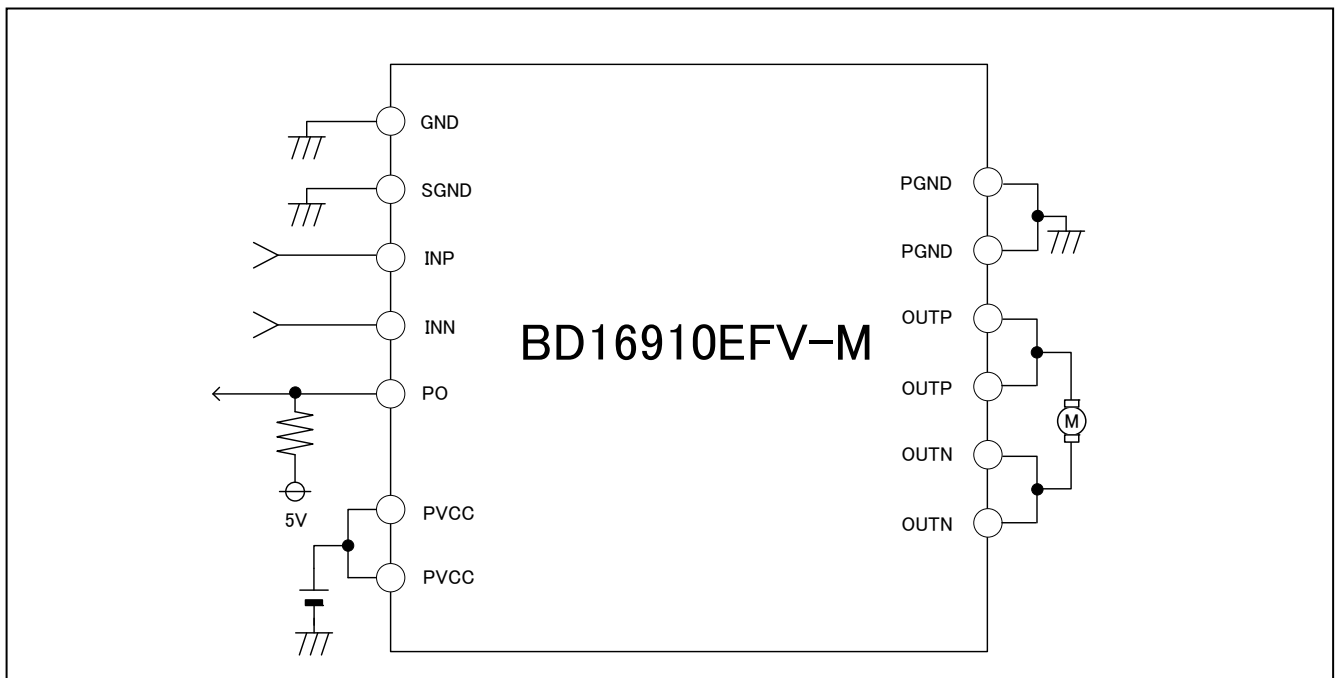

Figure1:Typical Application Circuits

○Product structure : Silicon monolithic integrated circuit
○This product is not designed protection against radioactive rays.

●Pin Configuration

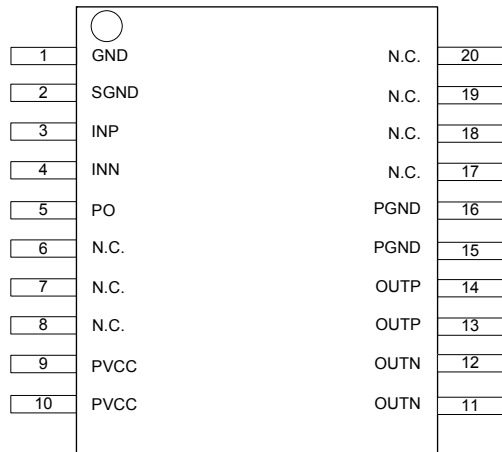

Figure2: Pin Configuration

●Pin description

HTSSOP -B20	Symbol	Description
1	GND	GND terminal
2	SGND	Small signal GND terminal
3	INP	Output state control input terminal
4	INN	Output state control input terminal
5	PO	Output state output terminal (Open drain)
6	N.C.	-
7	N.C.	-
8	N.C.	-
9	PVCC	Power supply terminal
10	PVCC	Power supply terminal
11	OUTN	Motor output terminal
12	OUTN	Motor output terminal
13	OUTP	Motor output terminal
14	OUTP	Motor output terminal
15	PGND	Output part GND terminal
16	PGND	Output part GND terminal
17	N.C.	-
18	N.C.	-
19	N.C.	-
20	N.C.	-

●Block Diagram(s)

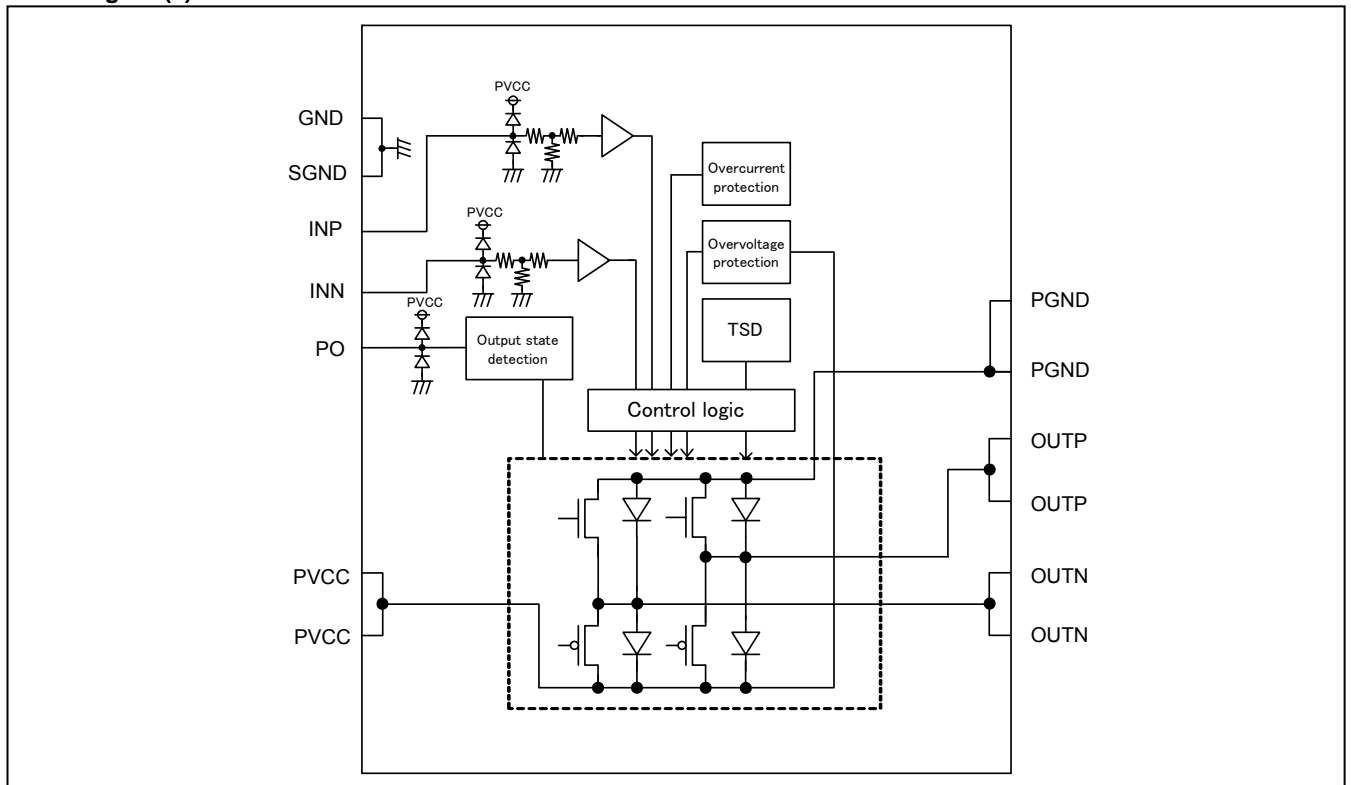

Figure3: Block Diagram

● **Absolute maximum ratings** (Ta=25°C)

Parameter	Symbol	Limits	Unit
Power supply voltage	PVCC	60	V
Output voltage	OUTP/OUTN	60	V
Input voltage	INP/INN	-0.3 to 20 *1	V
Output current	Io	1.0 *2	A
Power dissipation	Pd	3.19 *3	W
Operating temperature range	Topr	-40 to 110	°C
Storage temperature range	Tstg	-55 to 150	°C
Junction temperature	Tjmax	150	°C

● **Operating conditions** (Ta=25°C)

Parameter	Symbol	Limits	Unit
Range of Power-supply voltage operation	PVCC	8 to 16	V

*1 However, PVCC>INP/INN.

*2 However, exceed neither Pd nor ASO.

*3 IC mounted on ROHM standard board (70mm×70mm×1.6mm, glass epoxy 4 layers board)
Reduce power by 25.5mW for each degree above 25°C.

●Electrical characteristics

(Unless otherwise noted, PVCC= 8V to 16V, Ta = -40°C to 110°C)

Parameter	Symbol	Standard value			Unit	Condition
		MIN.	TYP.	MAX.		
Circuit current 1	Icc1	-	0	10	μA	Stand-by
Circuit current 2	Icc2	-	4	8	mA	Forward or reverse rotation
Circuit current 3	Icc3	-	4	8	mA	Brake
Input H voltage	VIH	3.0	-	-	V	
Input L voltage	VIL	-	-	1.0	V	
Input H current	IiH	-	50	100	μA	NP/INN = 5.0V, Inflow current
Input L current	IiL	-	0	10	μA	NP/INN = 0.0V, Outflow current
Output ON resistance1	RON1	-	2.25	3.50	Ω	PVCC = 12V to 16V, Io = 0.1A · 0.8A Ta = -40°C to 25°C, Upper and lower total
Output ON resistance 2	RON2	-	3.00	4.13	Ω	PVCC = 8V to 12V, Io = 0.1A · 0.8A Ta = -40°C to 25°C, Upper and lower total
Output ON resistance 3	RON3	-	3.50	4.50	Ω	PVCC = 12V to 16V, Io = 0.1A · 0.8A Ta = 25°C to 110°C, Upper and lower total
Output ON resistance 4	RON4	-	4.75	5.75	Ω	PVCC = 8V to 12V, Io = 0.1A · 0.8A Ta = 25°C to 110°C, Upper and lower total
Output leak H	ILH	-	0	10	μA	OUTP/OUTN = 0V
Output leak L	ILL	-	0	10	μA	OUTP/OUTN = PVCC
Output diode voltage H	VFH	0.2	0.8	1.4	V	IF = 0.6A
Output diode voltage L	VFL	0.2	0.8	1.4	V	IF = 0.6A
Protection output voltage	VLPO	-	0.3	0.6	V	I = 3mA
Protection output leak current	ILPO	-	0	10	μA	PO = PVCC
Overcurrent detect current	IOCP	1.1	1.9	2.8	A	
TSD operation temperature	TTSD	150	175	-	°C	
Overvoltage detect voltage	VOVP	25	30	35	V	

◎A radiation is not designed.

●Truth table

Input		Output		Operation mode
INP	INN	OUTP	OUTN	
H	H	L	L	Brake
H	L	H	L	Forward rotation
L	H	L	H	Reverse rotation
L	L	Open	Open	Stand-by

● Timing chart

PO timing chart (INP=H, INN=L At Normal rotation, Ta=25°C)

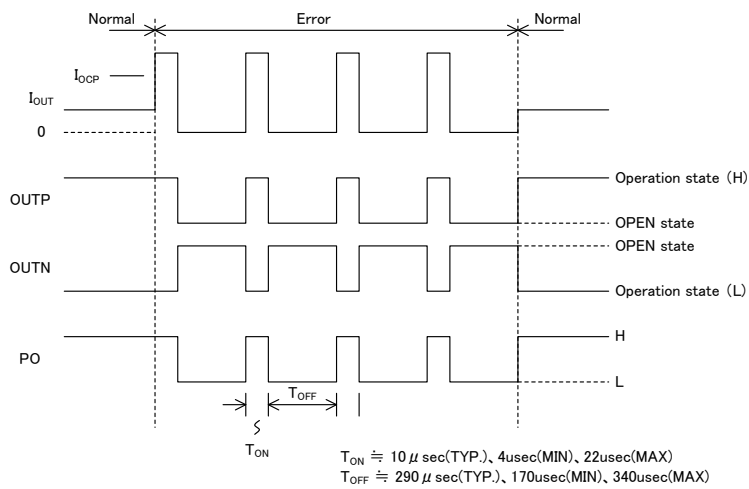

Figure4: PO timing chart (INP=H, INN=L at normal rotation)

Overvoltage protection timing chart

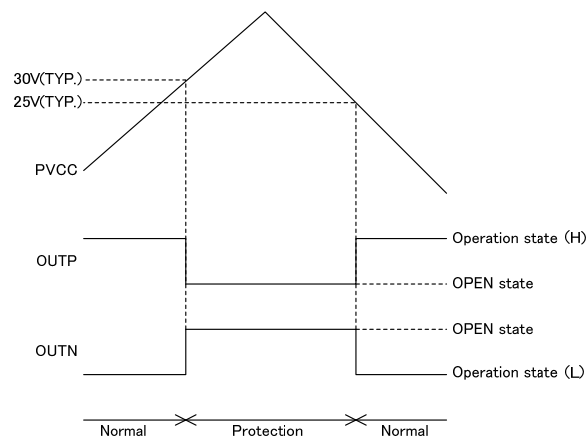

Figure5: Overvoltage protection timing chart

TSD timing chart

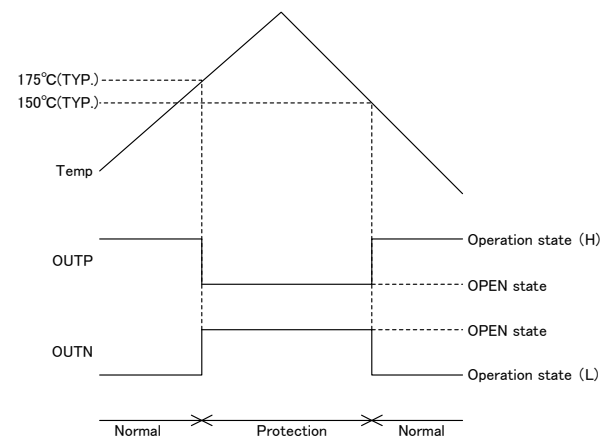

Figure6: TSD timing chart

●Example of recommended circuit

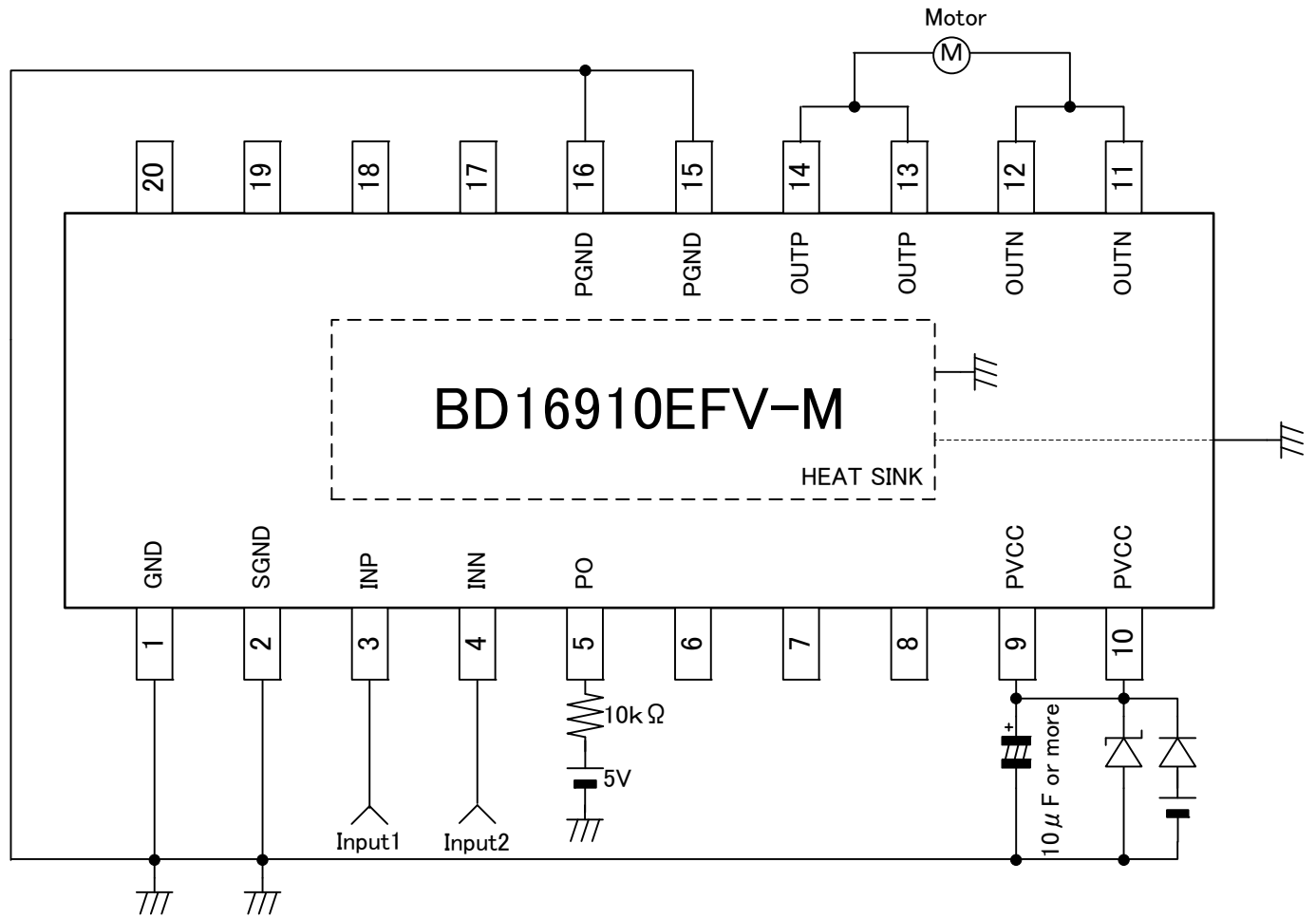

Figure7: BD16910EFV-M Recommended circuit diagram

- ※The external circuit constant in figure is a recommended value.
- ※External resistance of PO is a pull-up resistor.
- ※Please wire the vicinity of the pin of IC for the power supply decoupling capacitor.

●Power dissipation

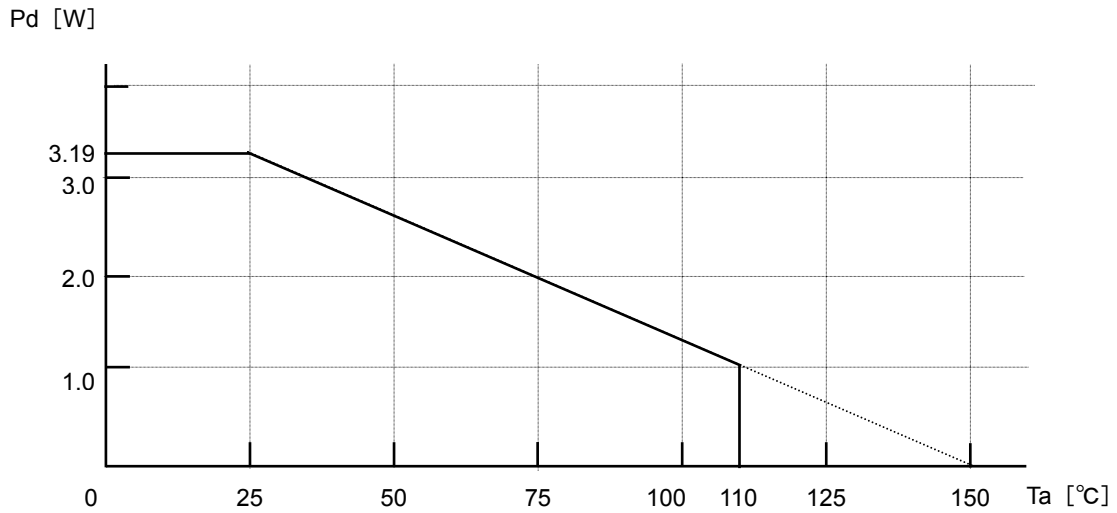

Figure8: BD16910EFV-M Power dissipation

IC mounted on ROHM standard board (70mm×70mm×1.6mm, glass epoxy 4 layers board)
Reduce power by 25.5mW for each degree above 25°C.

●ASO(Area of Safety Operation)

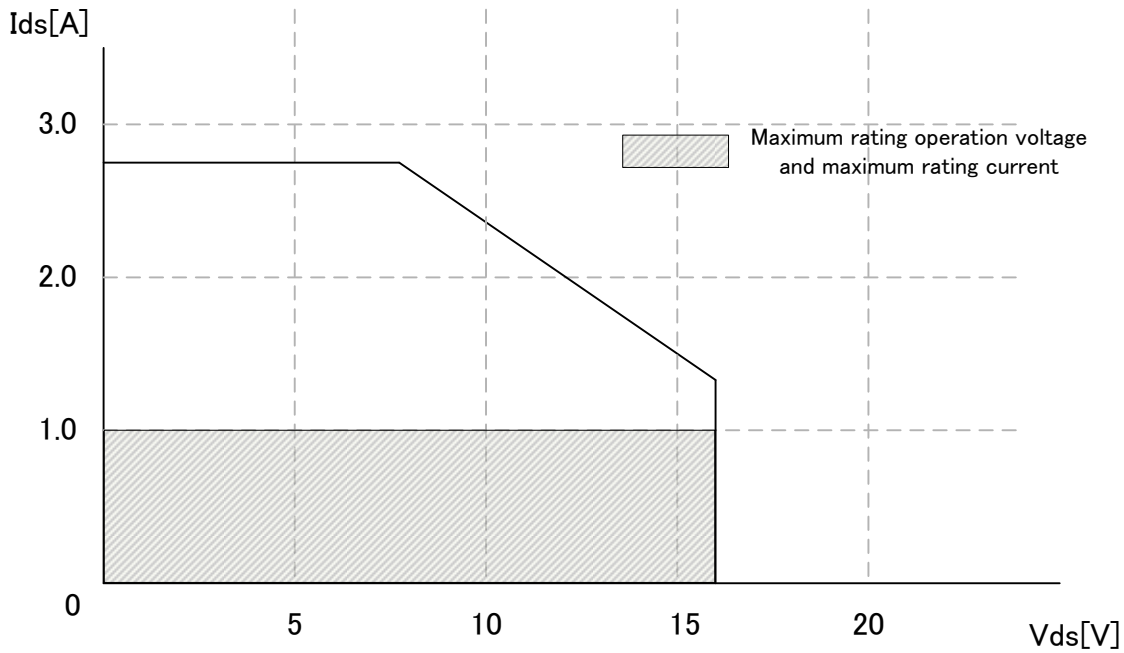

Figure9: BD16910EFV-M ASO characteristic

●Input / Output circuit diagram

※Resistance in figure is Typ value.

1) INP / INN

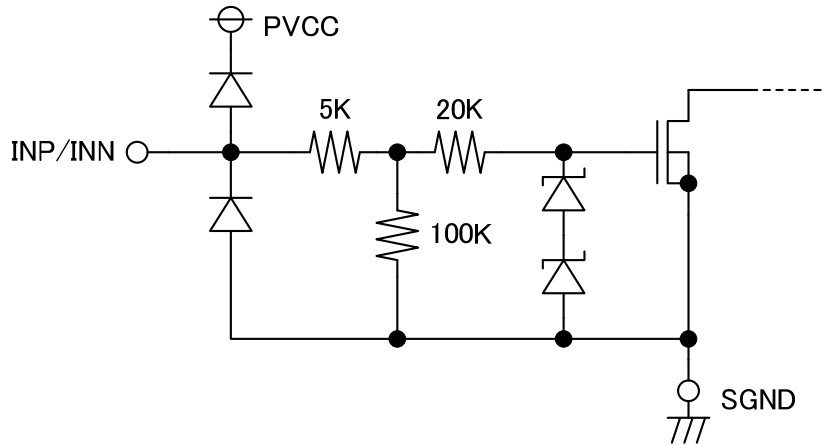

Figure10: Input circuit diagram

2) PO

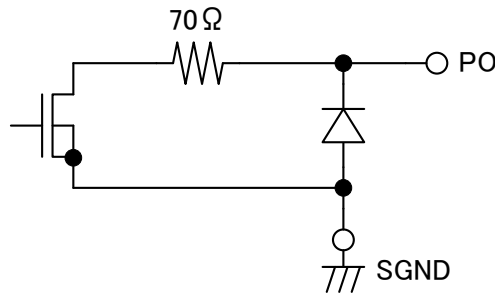

Figure11: PO circuit diagram

3) OUTP / OUTN

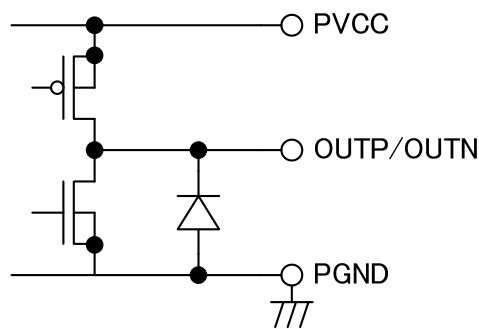

Figure12: Output circuit diagram

●Operational Notes

- 1) Absolute maximum ratings
We are careful enough for quality control about this IC. So, there is no problem under normal operation, excluding that it exceeds the absolute maximum ratings. However, this IC might be destroyed when the absolute maximum ratings, such as impressed voltages or the operating temperature range (Topr) is exceeded, and whether the destruction is short circuit mode or open circuit mode cannot be specified. Please take into consideration the physical countermeasures for safety, such as fusing, if a particular mode that exceeds the absolute maximum rating is assumed.
- 2) GND line
The ground line is where the lowest potential and transient voltages are connected to the IC.
Please keep the lowest potential any state of operation about the potential of 1, 2, 15,16PIN and the heat radiation pad on the back of the package.
- 3) Input terminal
Please do not add the voltage to each input terminal when you do not impress PVCC to IC.
Please set the voltage in each input terminal within the range of the guarantee of an electric characteristic or voltage of PVCC or less when you impress the PVCC voltage.
- 4) Reversely electromotive pressure
Reversely electromotive pressure might change depending on use conditions, the environment and individual characteristic of the motor. Please confirm there is no problem in the operation of IC etc. by reversely electromotive pressure enough.
- 5) Large current line
A large current flows to motor power supply PVCC and motor PGND terminal of IC. Therefore, the return to the input by this large current is caused according to the external circuit constant of the capacity of the capacitor between power supply-GND and board pattern layout. It becomes an undesirable result like the malfunction and the oscillation, etc.
- 6) PVCC
Please put the power supply decoupling capacitor between power supply and GND.
Please confirm there is no problem in various characteristics enough and decide the capacity value.
Recommended value is 10uF as shown in P.6
- 7) Power dissipation
Power dissipation is changed by the state of the board mounting and the mounting environment of IC, and take care enough about the heat design.
- 8) Power consumption
Power consumption changes greatly depending on the power supply voltage and the output current. Please design heat after considering the thermal resistance data and the transition thermal resistance data so as not to exceed ratings in consideration of power dissipation.
- 9) ASO
Please set not to exceed ASO (area of safe operation) the output current and the power supply voltage.
- 10) The circuit that limits the inrush current is not built into this IC. Therefore, please do physical measures such as putting the current limitation resistance.
- 11) There is a possibility that the trouble of the malfunction occurs if the potential of the output terminal widely swings to the potential of GND or less according to the condition of generation of heat, the power-supply voltage, and the use motor in this IC. For that case, please do measures that trouble doesn't occur such as Shottky diode is added between outputs-GND.
- 12) Operation in strong electromagnetic field
This IC doesn't do the design that assumes use in strong electromagnetic field. Please confirm there is no problem in the operation of IC by the board pattern layout and the circuit constant enough
- 13) Heat radiation pad
The heat radiation pad is connected with sub of IC, and connect with the GND potential.
Please do not use the heat radiation pad as GND wiring.

14) Overpower supply voltage output OFF function

Overpower-supply voltage output OFF function is built into as output protection at the overvoltage this IC. When the impressed voltage to the terminal PVCC becomes 30V(typ) or more, the output terminal is opened. However, it becomes only normal rotation · reverse rotation · a brake as an operation condition. Please note that this function doesn't operate at the standby. Please do not exceed the absolute maximum rating so that there is a possibility of destruction when the absolute maximum rating of the power-supply voltage is exceeded though overpower-supply voltage output OFF function is built into.

15) Overcurrent protection

The overcurrent protection circuit is built into as destruction measures of output short in this IC. This circuit opens the output during 290µsec(typ) when the current of 1.9A(typ) flows during 10µsec(typ), and returns to normal operation afterwards. If the overcurrent keeps flowing when returning normally, this state is repeated. Generation of heat and the deterioration of IC occur when the state of the overcurrent continues though the overcurrent protection is a function to prevent IC being destroyed by a short output etc. When the state continues keeping the flow of the overcurrent by using the terminal PO (When operating that the terminal PO shows in P.6), please do measures such as making IC a standby in the application.

16) Thermal shutdown

The thermal shutdown circuit is built into as an overheating protection measures this IC. When the Chip temperature of IC becomes 175°C(typ) or more, the output is opened. When the Chip temperature of IC becomes 150°C(typ) or less, returns to normal operation. The thermal shutdown circuit aims to intercept IC from high temperature. The guarantee and protection of IC are not purpose. Therefore, please do not use this IC after thermal shutdown circuit operates, nor use it for assumption that operates the thermal shutdown circuit.

17) Input terminal

This IC is a monolithic IC, and has P+ isolation and P substrate for the element separation. Therefore, a parasitic PN junction is formed in this P-layer and N-layer of each element. For instance, the resistor or the transistor is connected to the terminal as shown in the figure below. When the GND voltage potential is greater than the voltage potential at Terminals A or B, the PN junction operates as a parasitic diode. In addition, the parasitic NPN transistor is formed in said parasitic diode and the N layer of surrounding elements close to said parasitic diode. These parasitic elements are formed in the IC because of the voltage relation. The parasitic element operating causes the wrong operation and destruction. Therefore, please be careful so as not to operate the parasitic elements by impressing to input terminals lower voltage than GND(P substrate). Please do not apply the voltage to the input terminal when the power-supply voltage is not impressed. Moreover, please impress each input terminal lower than the power-supply voltage or equal to the specified range in the guaranteed voltage when the power-supply voltage is impressing.

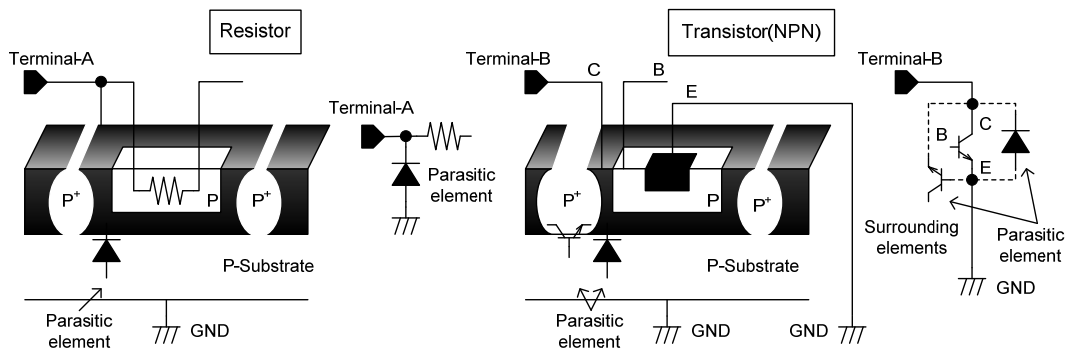
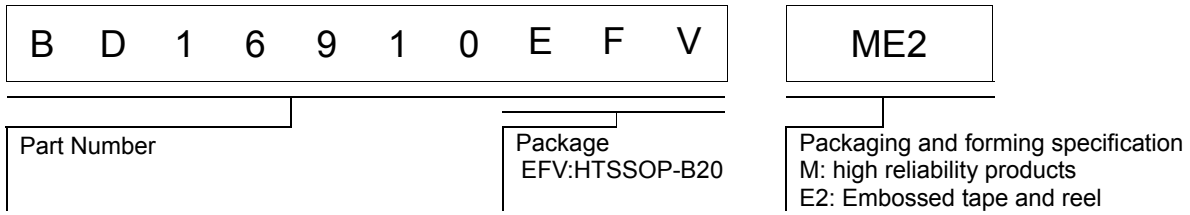

Figure13: Simplified structure of IC

The Japanese version of this document is formal specification. A customer may use this translation version only for a reference to help reading the formal version.

If there are any differences in translation version of this document formal version takes priority

● Ordering Information



● Physical Dimension Tape and Reel Information

HTSSOP-B20

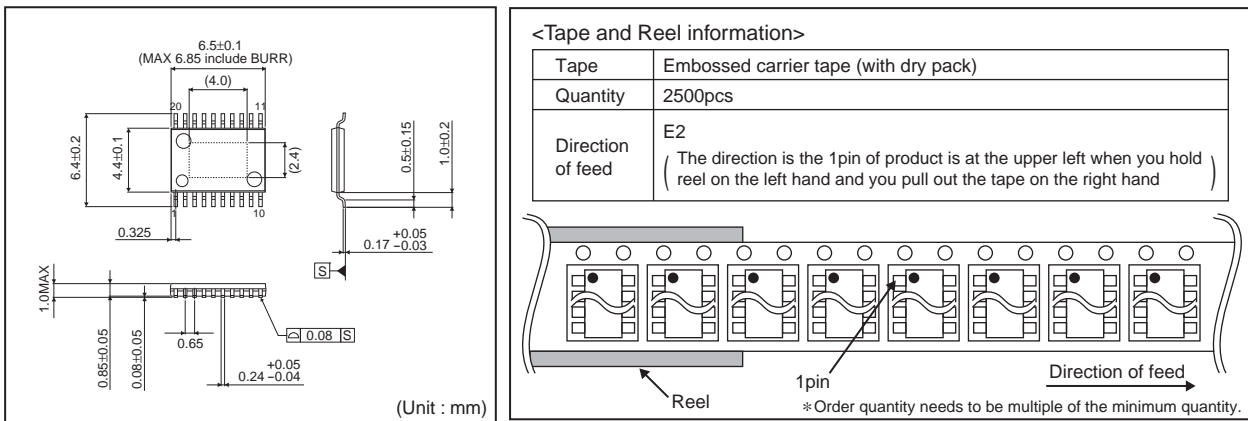

● Marking Diagram(s)(TOP VIEW)

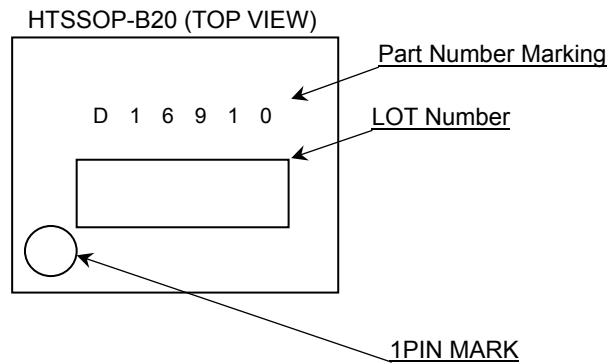

Notice

●General Precaution

- 1) Before you use our Products, you are requested to carefully read this document and fully understand its contents. ROHM shall not be in any way responsible or liable for failure, malfunction or accident arising from the use of any ROHM's Products against warning, caution or note contained in this document.
- 2) All information contained in this document is current as of the issuing date and subject to change without any prior notice. Before purchasing or using ROHM's Products, please confirm the latest information with a ROHM sales representative.

●Precaution on using ROHM Products

- 1) Our Products are designed and manufactured for application in ordinary electronic equipments (such as AV equipment, OA equipment, telecommunication equipment, home electronic appliances, amusement equipment, etc.). If you intend to use our Products in devices requiring extremely high reliability (such as medical equipment, transport equipment, traffic equipment, aircraft/spacecraft, nuclear power controllers, fuel controllers, car equipment including car accessories, safety devices, etc.) and whose malfunction or failure may cause loss of human life, bodily injury or serious damage to property ("Specific Applications"), please consult with the ROHM sales representative in advance. Unless otherwise agreed in writing by ROHM in advance, ROHM shall not be in any way responsible or liable for any damages, expenses or losses incurred by you or third parties arising from the use of any ROHM's Products for Specific Applications.
- 2) ROHM designs and manufactures its Products subject to strict quality control system. However, semiconductor products can fail or malfunction at a certain rate. Please be sure to implement, at your own responsibilities, adequate safety measures including but not limited to fail-safe design against the physical injury, damage to any property, which a failure or malfunction of our Products may cause. The following are examples of safety measures:
 - [a] Installation of protection circuits or other protective devices to improve system safety
 - [b] Installation of redundant circuits to reduce the impact of single or multiple circuit failure
- 3) Our Products are designed and manufactured for use under standard conditions and not under any special or extraordinary environments or conditions, as exemplified below. Accordingly, ROHM shall not be in any way responsible or liable for any damages, expenses or losses arising from the use of any ROHM's Products under any special or extraordinary environments or conditions. If you intend to use our Products under any special or extraordinary environments or conditions (as exemplified below), your independent verification and confirmation of product performance, reliability, etc. prior to use, must be necessary:
 - [a] Use of our Products in any types of liquid, including water, oils, chemicals, and organic solvents
 - [b] Use of our Products outdoors or in places where the Products are exposed to direct sunlight or dust
 - [c] Use of our Products in places where the Products are exposed to sea wind or corrosive gases, including Cl₂, H₂S, NH₃, SO₂, and NO₂
 - [d] Use of our Products in places where the Products are exposed to static electricity or electromagnetic waves
 - [e] Use of our Products in proximity to heat-producing components, plastic cords, or other flammable items
 - [f] Sealing or coating our Products with resin or other coating materials
 - [g] Use of our Products without cleaning residue of flux (even if you use no-clean type fluxes, cleaning residue of flux is recommended); or Washing our Products by using water or water-soluble cleaning agents for cleaning residue after soldering
 - [h] Use of the Products in places subject to dew condensation
- 4) The Products are not subject to radiation-proof design.
- 5) Please verify and confirm characteristics of the final or mounted products in using the Products.
- 6) In particular, if a transient load (a large amount of load applied in a short period of time, such as pulse) is applied, confirmation of performance characteristics after on-board mounting is strongly recommended. Avoid applying power exceeding normal rated power; exceeding the power rating under steady-state loading condition may negatively affect product performance and reliability.
- 7) De-rate Power Dissipation (Pd) depending on Ambient temperature (Ta). When used in sealed area, confirm the actual ambient temperature.
- 8) Confirm that operation temperature is within the specified range described in the product specification.
- 9) ROHM shall not be in any way responsible or liable for failure induced under deviant condition from what is defined in this document.

● **Precaution for Mounting / Circuit board design**

- 1) When a highly active halogenous (chlorine, bromine, etc.) flux is used, the residue of flux may negatively affect product performance and reliability.
- 2) In principle, the reflow soldering method must be used; if flow soldering method is preferred, please consult with the ROHM representative in advance.

For details, please refer to ROHM Mounting specification

● **Precautions Regarding Application Examples and External Circuits**

- 1) If change is made to the constant of an external circuit, please allow a sufficient margin considering variations of the characteristics of the Products and external components, including transient characteristics, as well as static characteristics.
- 2) You agree that application notes, reference designs, and associated data and information contained in this document are presented only as guidance for Products use. Therefore, in case you use such information, you are solely responsible for it and you must exercise your own independent verification and judgment in the use of such information contained in this document. ROHM shall not be in any way responsible or liable for any damages, expenses or losses incurred by you or third parties arising from the use of such information.

● **Precaution for Electrostatic**

This Product is electrostatic sensitive product, which may be damaged due to electrostatic discharge. Please take proper caution in your manufacturing process and storage so that voltage exceeding the Products maximum rating will not be applied to Products. Please take special care under dry condition (e.g. Grounding of human body / equipment / solder iron, isolation from charged objects, setting of Ionizer, friction prevention and temperature / humidity control).

● **Precaution for Storage / Transportation**

- 1) Product performance and soldered connections may deteriorate if the Products are stored in the places where:
 - [a] the Products are exposed to sea winds or corrosive gases, including Cl₂, H₂S, NH₃, SO₂, and NO₂
 - [b] the temperature or humidity exceeds those recommended by ROHM
 - [c] the Products are exposed to direct sunshine or condensation
 - [d] the Products are exposed to high Electrostatic
- 2) Even under ROHM recommended storage condition, solderability of products out of recommended storage time period may be degraded. It is strongly recommended to confirm solderability before using Products of which storage time is exceeding the recommended storage time period.
- 3) Store / transport cartons in the correct direction, which is indicated on a carton with a symbol. Otherwise bent leads may occur due to excessive stress applied when dropping of a carton.
- 4) Use Products within the specified time after opening a humidity barrier bag. Baking is required before using Products of which storage time is exceeding the recommended storage time period.

● **Precaution for Product Label**

QR code printed on ROHM Products label is for ROHM's internal use only.

● **Precaution for Disposition**

When disposing Products please dispose them properly using an authorized industry waste company.

● **Precaution for Foreign Exchange and Foreign Trade act**

Since our Products might fall under controlled goods prescribed by the applicable foreign exchange and foreign trade act, please consult with ROHM representative in case of export.

● **Precaution Regarding Intellectual Property Rights**

- 1) All information and data including but not limited to application example contained in this document is for reference only. ROHM does not warrant that foregoing information or data will not infringe any intellectual property rights or any other rights of any third party regarding such information or data. ROHM shall not be in any way responsible or liable for infringement of any intellectual property rights or other damages arising from use of such information or data.:
- 2) No license, expressly or implied, is granted hereby under any intellectual property rights or other rights of ROHM or any third parties with respect to the information contained in this document.

●Other Precaution

- 1) The information contained in this document is provided on an "as is" basis and ROHM does not warrant that all information contained in this document is accurate and/or error-free. ROHM shall not be in any way responsible or liable for any damages, expenses or losses incurred by you or third parties resulting from inaccuracy or errors of or concerning such information.
- 2) This document may not be reprinted or reproduced, in whole or in part, without prior written consent of ROHM.
- 3) The Products may not be disassembled, converted, modified, reproduced or otherwise changed without prior written consent of ROHM.
- 4) In no event shall you use in any way whatsoever the Products and the related technical information contained in the Products or this document for any military purposes, including but not limited to, the development of mass-destruction weapons.
- 5) The proper names of companies or products described in this document are trademarks or registered trademarks of ROHM, its affiliated companies or third parties.

Notice

●General Precaution

- 1) Before you use our Products, you are requested to carefully read this document and fully understand its contents. ROHM shall not be in any way responsible or liable for failure, malfunction or accident arising from the use of any ROHM's Products against warning, caution or note contained in this document.
- 2) All information contained in this document is current as of the issuing date and subject to change without any prior notice. Before purchasing or using ROHM's Products, please confirm the latest information with a ROHM sales representative.

●Precaution on using ROHM Products

- 1) Our Products are designed and manufactured for application in ordinary electronic equipments (such as AV equipment, OA equipment, telecommunication equipment, home electronic appliances, amusement equipment, etc.). If you intend to use our Products in devices requiring extremely high reliability (such as medical equipment, transport equipment, traffic equipment, aircraft/spacecraft, nuclear power controllers, fuel controllers, car equipment including car accessories, safety devices, etc.) and whose malfunction or failure may cause loss of human life, bodily injury or serious damage to property ("Specific Applications"), please consult with the ROHM sales representative in advance. Unless otherwise agreed in writing by ROHM in advance, ROHM shall not be in any way responsible or liable for any damages, expenses or losses incurred by you or third parties arising from the use of any ROHM's Products for Specific Applications.
- 2) ROHM designs and manufactures its Products subject to strict quality control system. However, semiconductor products can fail or malfunction at a certain rate. Please be sure to implement, at your own responsibilities, adequate safety measures including but not limited to fail-safe design against the physical injury, damage to any property, which a failure or malfunction of our Products may cause. The following are examples of safety measures:
 - [a] Installation of protection circuits or other protective devices to improve system safety
 - [b] Installation of redundant circuits to reduce the impact of single or multiple circuit failure
- 3) Our Products are designed and manufactured for use under standard conditions and not under any special or extraordinary environments or conditions, as exemplified below. Accordingly, ROHM shall not be in any way responsible or liable for any damages, expenses or losses arising from the use of any ROHM's Products under any special or extraordinary environments or conditions. If you intend to use our Products under any special or extraordinary environments or conditions (as exemplified below), your independent verification and confirmation of product performance, reliability, etc. prior to use, must be necessary:
 - [a] Use of our Products in any types of liquid, including water, oils, chemicals, and organic solvents
 - [b] Use of our Products outdoors or in places where the Products are exposed to direct sunlight or dust
 - [c] Use of our Products in places where the Products are exposed to sea wind or corrosive gases, including Cl₂, H₂S, NH₃, SO₂, and NO₂
 - [d] Use of our Products in places where the Products are exposed to static electricity or electromagnetic waves
 - [e] Use of our Products in proximity to heat-producing components, plastic cords, or other flammable items
 - [f] Sealing or coating our Products with resin or other coating materials
 - [g] Use of our Products without cleaning residue of flux (even if you use no-clean type fluxes, cleaning residue of flux is recommended); or Washing our Products by using water or water-soluble cleaning agents for cleaning residue after soldering
 - [h] Use of the Products in places subject to dew condensation
- 4) The Products are not subject to radiation-proof design.
- 5) Please verify and confirm characteristics of the final or mounted products in using the Products.
- 6) In particular, if a transient load (a large amount of load applied in a short period of time, such as pulse) is applied, confirmation of performance characteristics after on-board mounting is strongly recommended. Avoid applying power exceeding normal rated power; exceeding the power rating under steady-state loading condition may negatively affect product performance and reliability.
- 7) De-rate Power Dissipation (Pd) depending on Ambient temperature (Ta). When used in sealed area, confirm the actual ambient temperature.
- 8) Confirm that operation temperature is within the specified range described in the product specification.
- 9) ROHM shall not be in any way responsible or liable for failure induced under deviant condition from what is defined in this document.

● **Precaution for Mounting / Circuit board design**

- 1) When a highly active halogenous (chlorine, bromine, etc.) flux is used, the residue of flux may negatively affect product performance and reliability.
- 2) In principle, the reflow soldering method must be used; if flow soldering method is preferred, please consult with the ROHM representative in advance.

For details, please refer to ROHM Mounting specification

● **Precautions Regarding Application Examples and External Circuits**

- 1) If change is made to the constant of an external circuit, please allow a sufficient margin considering variations of the characteristics of the Products and external components, including transient characteristics, as well as static characteristics.
- 2) You agree that application notes, reference designs, and associated data and information contained in this document are presented only as guidance for Products use. Therefore, in case you use such information, you are solely responsible for it and you must exercise your own independent verification and judgment in the use of such information contained in this document. ROHM shall not be in any way responsible or liable for any damages, expenses or losses incurred by you or third parties arising from the use of such information.

● **Precaution for Electrostatic**

This Product is electrostatic sensitive product, which may be damaged due to electrostatic discharge. Please take proper caution in your manufacturing process and storage so that voltage exceeding the Products maximum rating will not be applied to Products. Please take special care under dry condition (e.g. Grounding of human body / equipment / solder iron, isolation from charged objects, setting of Ionizer, friction prevention and temperature / humidity control).

● **Precaution for Storage / Transportation**

- 1) Product performance and soldered connections may deteriorate if the Products are stored in the places where:
 - [a] the Products are exposed to sea winds or corrosive gases, including Cl₂, H₂S, NH₃, SO₂, and NO₂
 - [b] the temperature or humidity exceeds those recommended by ROHM
 - [c] the Products are exposed to direct sunshine or condensation
 - [d] the Products are exposed to high Electrostatic
- 2) Even under ROHM recommended storage condition, solderability of products out of recommended storage time period may be degraded. It is strongly recommended to confirm solderability before using Products of which storage time is exceeding the recommended storage time period.
- 3) Store / transport cartons in the correct direction, which is indicated on a carton with a symbol. Otherwise bent leads may occur due to excessive stress applied when dropping of a carton.
- 4) Use Products within the specified time after opening a humidity barrier bag. Baking is required before using Products of which storage time is exceeding the recommended storage time period.

● **Precaution for Product Label**

QR code printed on ROHM Products label is for ROHM's internal use only.

● **Precaution for Disposition**

When disposing Products please dispose them properly using an authorized industry waste company.

● **Precaution for Foreign Exchange and Foreign Trade act**

Since our Products might fall under controlled goods prescribed by the applicable foreign exchange and foreign trade act, please consult with ROHM representative in case of export.

● **Precaution Regarding Intellectual Property Rights**

- 1) All information and data including but not limited to application example contained in this document is for reference only. ROHM does not warrant that foregoing information or data will not infringe any intellectual property rights or any other rights of any third party regarding such information or data. ROHM shall not be in any way responsible or liable for infringement of any intellectual property rights or other damages arising from use of such information or data.:
- 2) No license, expressly or implied, is granted hereby under any intellectual property rights or other rights of ROHM or any third parties with respect to the information contained in this document.

●Other Precaution

- 1) The information contained in this document is provided on an "as is" basis and ROHM does not warrant that all information contained in this document is accurate and/or error-free. ROHM shall not be in any way responsible or liable for any damages, expenses or losses incurred by you or third parties resulting from inaccuracy or errors of or concerning such information.
- 2) This document may not be reprinted or reproduced, in whole or in part, without prior written consent of ROHM.
- 3) The Products may not be disassembled, converted, modified, reproduced or otherwise changed without prior written consent of ROHM.
- 4) In no event shall you use in any way whatsoever the Products and the related technical information contained in the Products or this document for any military purposes, including but not limited to, the development of mass-destruction weapons.
- 5) The proper names of companies or products described in this document are trademarks or registered trademarks of ROHM, its affiliated companies or third parties.