

AC/DC Drivers

PWM Control type DC/DC converter IC

BM1P061FJ / BM1P062FJ / BM1P101FJ / BM1P102FJ



●General

The PWM type DC/DC converter (BM1Pxxx) for AC/DC provide an optimum system for all products that include an electrical outlet.
 BM1Pxxx supports both isolated and non-isolated devices, enabling simpler design of various types of low-power electrical converters.
 BM1Pxxx built in a HV starter circuit that tolerates 650V, it contributes to low-power consumption.
 With switching MOSFET and current detection resistors as external devices, a higher degree of design freedom is achieved. Since current mode control is utilized, current is restricted in each cycle and excellent performance is demonstrated in bandwidth and transient response.
 At light load, the switching frequency is reduced and high efficiency is achieved.
 A frequency hopping function is also on chip, which contributes to low EMI.
 BM1Pxxx has rich protection.

●Features

- PWM frequency : 65kHz, 100kHz
- PWM current mode method
- Frequency Hopping function
- Burst operation / Frequency reduction function when load is light
- Built-in 650V start circuit
- VCC pin under voltage protection
- VCC pin over voltage protection
- CS pin Open protection
- CS pin Leading-Edge-Blanking function
- Per-cycle over current protection circuit
- Current protection with AC voltage compensation
- Soft start
- Secondary Over current protection circuit

●Basic specifications

- Operating Power Supply Voltage Range:
 VCC 8.9V to 26.0V
 VH : to 600V
- Operating Current: Normal Mode : 0.60mA (Typ.)
 Burst Mode : 0.35mA(Typ.)
- Oscillation Frequency: BM1P06xFJ : 65kHz(Typ.)
 BM1P10xFJ : 100kHz(Typ.)
- Operating Temperature: - 40deg. to +85deg.

●Package

SOP-J8 4.90mm×3.90mm ×1.65mm Pitch 1.27mm
 (Typ.) (Typ.) (TYP.) (TYP.)



●Applications

AC adapters and household appliances (vacuum cleaners, humidifiers, air cleaners, air conditioners, IH cooking heaters, rice cookers, etc.)

●Application circuit

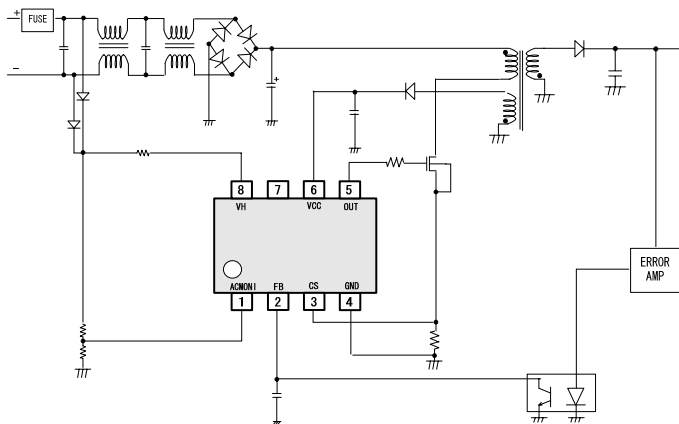

Figure 1. Application circuit

●Line-Up

	Frequency	VCCOVP
BM1P101FJ	100kHz	Auto Restart
BM1P102FJ	100kHz	Latch
BM1P061FJ	65kHz	Auto Restart
BM1P062FJ	65kHz	Latch

●Absolute Maximum Ratings (Ta=25°C)

Parameter	Symbol	Rating	Unit	Conditions
Maximum voltage 1	Vmax1	-0.3~30.0	V	VCC
Maximum voltage 2	Vmax2	-0.3~6.5	V	CS, FB, ACMONI
Maximum voltage 3	Vmax3	-0.3~15.0	V	OUT
Maximum voltage 4	Vmax4	-0.3~650	V	VH
OUT Pin Peak Current	I _{OUT}	±1.0	A	
Allowable dissipation	Pd	674.9 (Note1)	mW	When implemented
Operating temperature range	Topr	-40 ~ +85	°C	
Storage temperature range	Tstr	-55 ~ +150	°C	

(Note1) When mounted (on 70 mm × 70 mm, 1.6 mm thick, glass epoxy on single-layer substrate).
Reduce to 5.40 mW/°C when Ta = 25°C or above.

●Operating Conditions (Ta=25°C)

Parameter	Symbol	Rating	Unit	Conditions
Power supply voltage range 1	VCC	8.9~26.0	V	VCC pin voltage
Power supply voltage range 2	VH	80 ~600	V	VH pin voltage

●Electrical Characteristics (Unless otherwise noted, Ta = 25°C, VCC = 15 V)

Parameter	Symbol	Specifications			Unit	Conditions
		Minimum	Standard	Maximum		
[Circuit current]						
Circuit current (ON) 1	I _{ON1}	-	600	850	μA	FB=2.0V (during pulse operation)
Circuit current (ON) 2	I _{ON2}	-	350	450	μA	FB=0.0V (during burst operation)
[VCC protection function]						
VCC UVLO voltage 1	V _{UVLO1}	12.50	13.50	14.50	V	VCC rise
VCC UVLO voltage 2	V _{UVLO2}	7.50	8.20	8.90	V	VCC drop BM1P061FJ/BM1P101FJ
VCC UVLO hysteresis	V _{UVLO3}	-	5.30	-	V	V _{UVLO3} = V _{UVLO1} - V _{UVLO2}
VCC Recharge start voltage	V _{CHG1}	7.70	8.70	9.70	V	Start up circuit operation voltage
VCC Recharge stop voltage	V _{CHG2}	12.00	13.00	14.00	V	The stop voltage from V _{CHG1}
VCC OVP voltage 1	V _{OVP1}	26.0	27.5	29.0	V	VCC rise
VCC OVP voltage 2	V _{OVP2}	-	23.5	-	V	VCC drop BM1P061FJ/BM1P101FJ
VCC OVP hysteresis	V _{OVP3}	-	4.00	-	V	BM1P061FJ/BM1P101FJ
[OUT pin]						
OUT Pin High voltage	V _{OUTH}	10.5	12.5	14.5	V	IO=-20mA
OUT Pin Low voltage	V _{OUTL}	-	-	1.00	V	IO=+20mA
OUT Pin pull down resistance	R _{PDOUT}	75	100	125	kΩ	
[ACMONI Detector]						
ACMONI detect voltage1	V _{ACMONI1}	0.92	1.00	1.08	V	ACMONI rise
ACMONI detect voltage2	V _{ACMONI2}	0.63	0.70	0.77	V	ACMONI drop
ACMONI hysteresis	V _{ACMONI3}	0.20	0.30	0.40	V	
ACMONI Timer	T _{ACMONI1}	180	256	330	mS	
[Start circuit block]						
Start current 1	I _{START1}	0.400	0.700	1.000	mA	VCC= 0V
Start current 2	I _{START2}	1.000	3.000	5.000	mA	VCC=10V
OFF current	I _{START3}	-	10	20	uA	Inflow current from Drain pin after UVLO released UVLO
Start current changing voltage	V _{SC}	0.400	0.800	1.400	V	

●Electrical Characteristics (Unless otherwise noted, Ta = 25°C, VCC = 15 V)

Parameter	Symbol	Specifications			Unit	Conditions
		Minimum	Standard	Maximum		
[PWM type DCDC driver block]						
Oscillation frequency 1a	F _{SW1a}	60	65	70	kHz	FB=2.00V average frequency BM1P061FJ/BM1P062FJ
Oscillation frequency 1b	F _{SW1b}	90	100	110	kHz	FB=2.00V average frequency BM1P101FJ/BM1P102FJ
Oscillation frequency 2	F _{SW2}	-	25	-	kHz	FB=0.40V average frequency
Hopping fluctuation frequency range 1	F _{DEL1}	-	4.0	-	kHz	FB=2.00V average frequency BM1P061FJ/BM1P062FJ
Hopping fluctuation frequency range 2	F _{DEL2}	-	6.0	-	kHz	FB=2.00V average frequency BM1P101FJ/BM1P102FJ
Hopping fluctuation frequency	F _{CH}	75	125	175	Hz	
Minimum pulse width	T _{min}	-	400	-	ns	
Soft start time 1	T _{SS1}	0.30	0.50	0.70	ms	
Soft start time 2	T _{SS2}	0.60	1.00	1.40	ms	
Soft start time 3	T _{SS3}	1.20	2.00	2.80	ms	
Soft start time 4	T _{SS4}	2.40	4.00	5.60	ms	
Maximum duty	D _{max}	68.0	75.0	82.0	%	
FB pin pull-up resistance	R _{FB}	22	30	38	kΩ	
FB / CS gain	Gain	-	4.00	-	V/V	
FB burst voltage 1	V _{BST1}	0.300	0.400	0.500	V	FB drop
FB burst voltage 2	V _{BST2}	0.350	0.450	0.550	V	FB drop
FB OLP voltage 1a	V _{FOLP1A}	2.60	2.80	3.00	V	When overload is detected (FB rise)
FB OLP voltage 1b	V _{FOLP1B}	-	V _{FOLP2A} -0.2	-	V	When overload is detected (FB drop)
FB OLP ON timer	T _{FOLP}	44	64	84	ms	
FB OLP Start up timer	T _{FOLP2}	26	32	38	ms	
FB OLP OFF timer	T _{OLPST}	358	512	666	ms	
Latch released VCC voltage	V _{LATCH}	-	V _{UVLO2} -0.5	-	V	VCC Pin voltage BM1P062FJ/BM1P102FJ
Latch mask time	T _{LATCH}	50	100	200	us	VCCOVP BM1P062FJ/BM1P102FJ
[Over current detection block]						
Over current detection voltage	V _{CS}	0.380	0.400	0.420	V	Ton=0us
Over current detection voltage SS1	V _{CS_SS1}	-	0.100	-	V	0[ms] ~ Tss1[ms]
Over current detection voltage SS2	V _{CS_SS2}	-	0.150	-	V	TSS1 [ms] ~ TSS2 [ms]
Over current detection voltage SS3	V _{CS_SS3}	-	0.200	-	V	TSS2 [ms] ~ TSS3[ms]
Over current detection voltage SS4	V _{CS_SS4}	-	0.300	-	V	TSS3 [ms] ~ TSS4 [ms]
Leading Edge Blanking Time	T _{LEB}	-	250	-	ns	
Over current detection AC Voltage compensation factor	K _{CS}	12	20	28	mV/us	

●PIN DESCRIPTIONS

Table 1. Pin Description

NO.	Pin Name	I/O	Function	ESD Diode	
				VCC	GND
1	ACMONI	I	Comparator input pin	○	○
2	FB	I	Feedback signal input pin	○	○
3	CS	I	Primary Current sense pin	○	○
4	GND	I/O	GND pin	○	-
5	OUT	O	External MOSFET driver pin	○	○
6	VCC	I/O	Power supply input pin	-	○
7	N.C.	-	Non Connection	-	-
8	VH	I	Starter pin	-	○

●I/O Equivalent Circuit Diagram

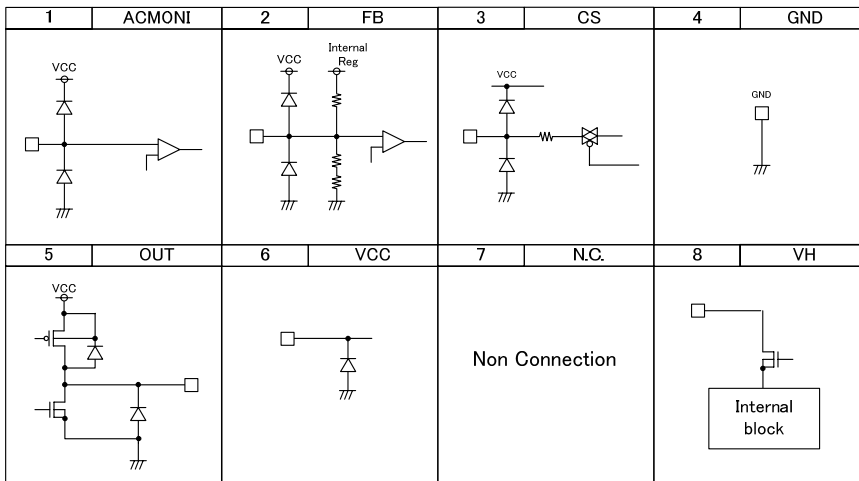

Figure 2. I/O Equivalent Circuit Diagram

●Block Diagram

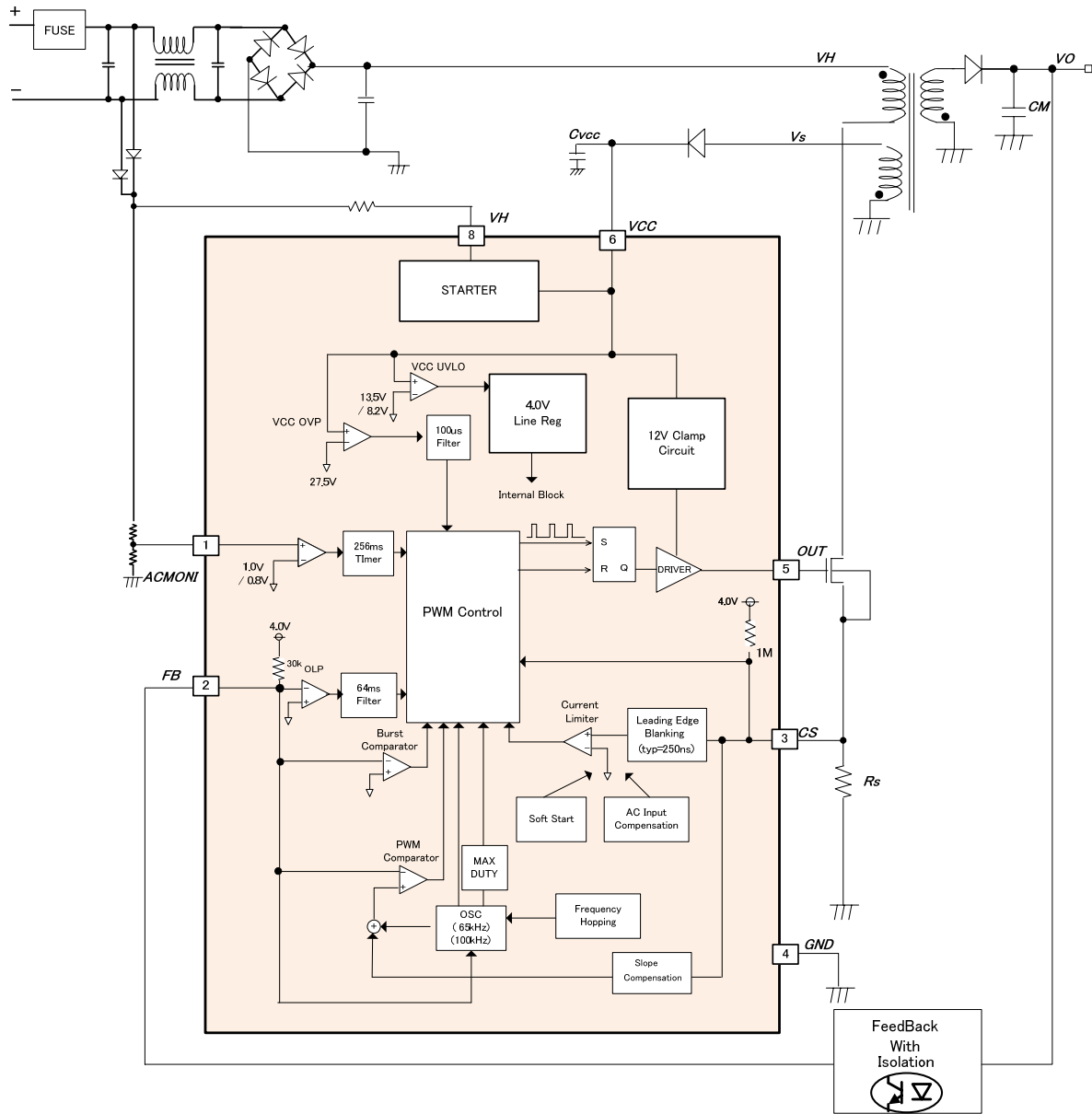

Figure 3. Block Diagram

•Description of Blocks

(1) Start circuit (VH Pin : 8pin)

This IC built in the Start up circuit (tolerates 650V). It enables to be low standby mode electricity and high speed starting. After starting, consumption power is idling current I_{START3} (typ=10uA) only. Reference values of Starting time are shown in Figure-6. When $C_{VCC}=10\mu F$ it can start less than 0.1 sec.

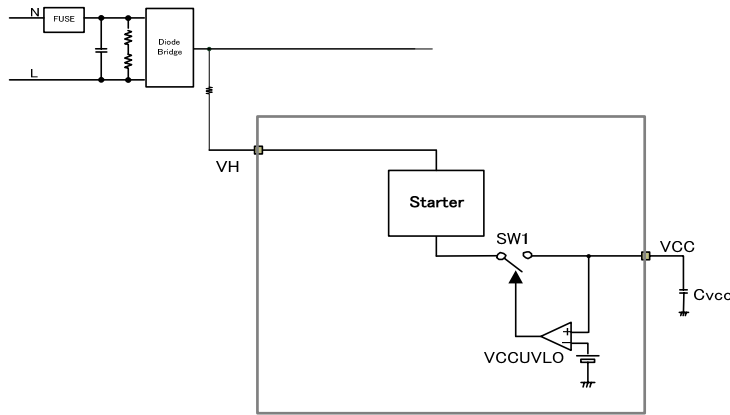

Figure 4. Block diagram of start up circuit

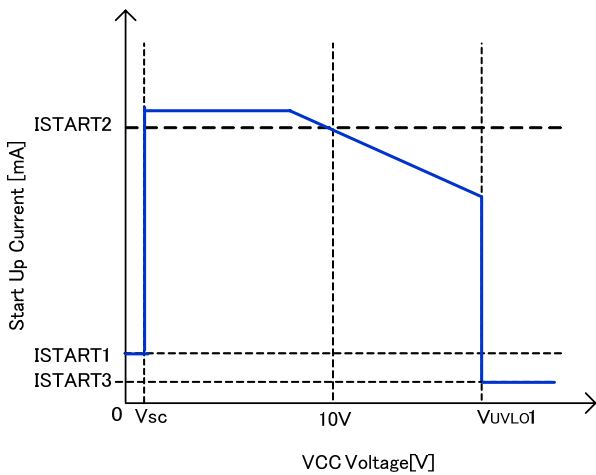

Figure 5. Start current vs VCC voltage

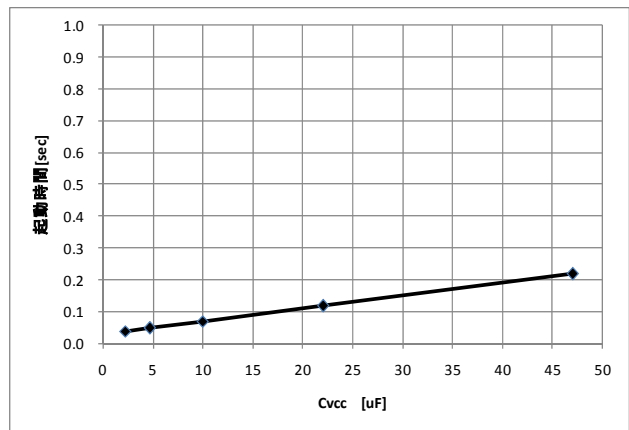

Figure 6. Start time(reference value)

* Start up current flows from the DRAIN pin

ex) Consumption power of start up circuit only when the $V_{ac}=100V$
 $P_{VH}=100V \cdot \sqrt{2} \cdot 10\mu A = 1.41mW$

ex) Consumption power of start up circuit only when the $V_{ac}=240V$
 $P_{VH}=240V \cdot \sqrt{2} \cdot 10\mu A = 3.38mW$

(2) Start sequences

(Soft start operation, light load operation, and auto recovery operation during overload protection)

Start sequences are shown in Figure 7. See the sections below for detailed descriptions.

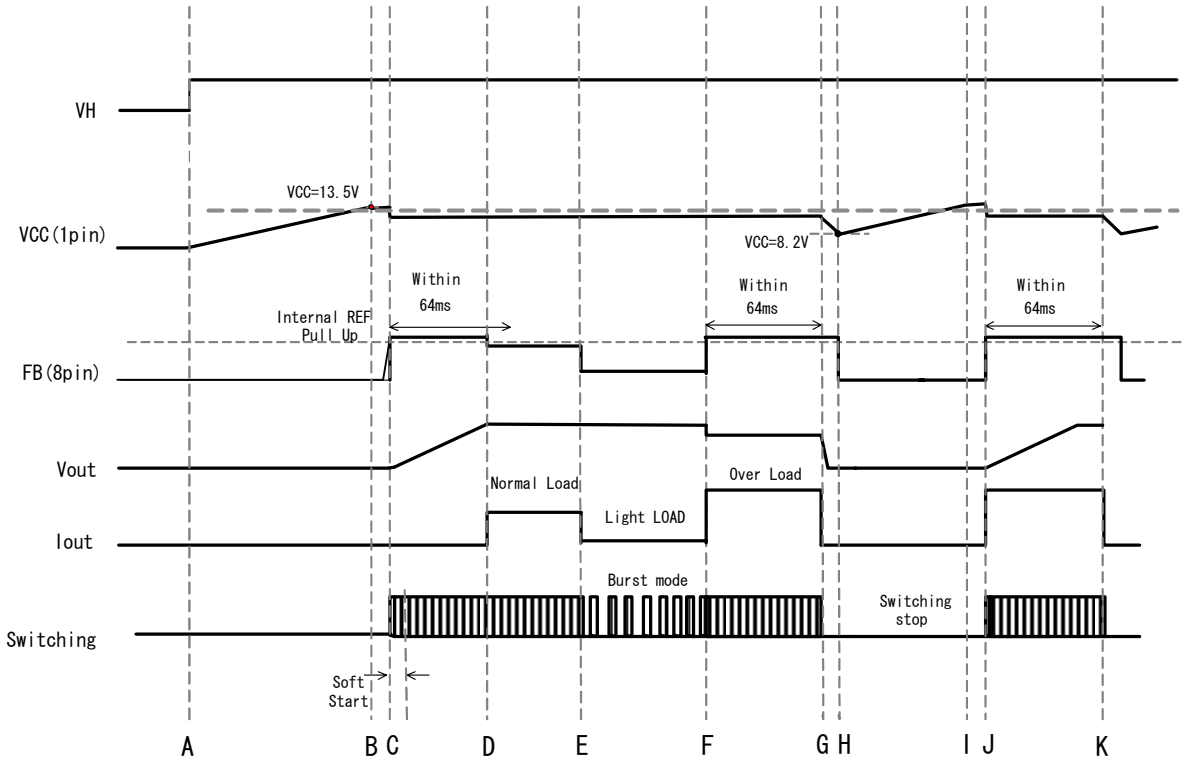

Figure 7. Start sequences Timing Chart

A : Input voltage V_H is applied

B : This IC starts operating , when V_{CC} pin voltage rises $V_{CC} > V_{UVLO1}$ (13.5 V typ).

Switching function starts when other protection functions are judged as normal.

Between the secondary output voltage become constant level, because the V_{CC} pin consumption current causes the V_{CC} value to drop, IC should set to start switching until $V_{CC} < V_{UVLO2}$ (8.2V typ).

C : With the soft start function, over current limit value is restricted to prevent any excessive rise in voltage or current.

D : When the switching operation starts, V_{OUT} rises.

Once the output voltage starts, set the rated voltage within the T_{FOLP2} period (32ms typ).

E : When there is a light load it reaches FB voltage $< V_{BST}$ (= 0.4Vtyp, burst operation is used to keep power consumption down.

During burst operation, it becomes low-power consumption mode.

F : When the FB Voltage $> V_{FOLP1A}$ (=2.8V.typ), it becomes a overload

G: When FB pin voltage keeps V_{FOLP1A} (= 2.8V typ), the overload protection function is triggered and switching stops. During the T_{FOLP} period (32ms typ) if the FB pin voltage becomes $FB < V_{FOLP1B}$ even once, the IC's internal timer is reset.

H : If the V_{CC} voltage drops to $V_{CC} < V_{UVLO2}$ (7.7Vtyp) or below, restart is executed.

I : The IC's circuit current is reduced and the V_{CC} pin value rises. (Same as B)

J : Same as F

K : Same as G

(3) VCC pin protection function

BM1Pxxx built in VCCUVLO (Under Voltage Lock Out), VCC OVP (Over Voltage Protection) and VCC charge function that operates in case of dropping the VCC voltage.
 This function monitors VCC pin and prevent VCC pin from destroying switching MOSFET at abnormal voltage.
 VCC charge function stabilizes the secondary output voltage to be charged from the high voltage line by start circuit when dropping the VCC voltage.

(3-1) VCC UVLO / VCC OVP function

VCCUVLO is auto recovery comparator. BM1Pxx1 series have auto recovery type VCCOVP that has voltage hysteresis. BM1Pxx2 series has latch type VCCOVP.
 Refer to the operation figure-8.
 VCCOVP operates detection in case of continuing VCC pin voltage $> V_{OVP1}$ (typ=27.5V).
 This function built in mask time T_{LATCH} (typ=100us). By this function, this IC masks pin generated surge etc. (please refer to section (7))

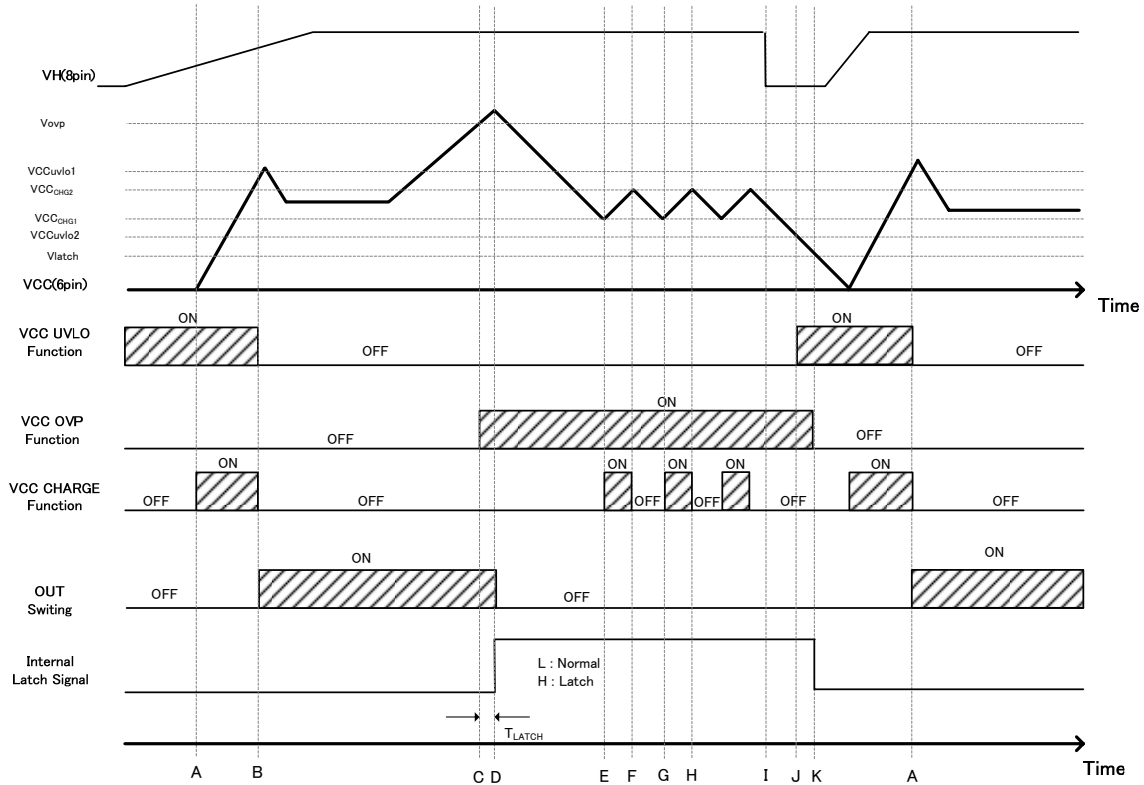

Figure 8. VCC UVLO / OVP Timing Chart

- A: The V_H pin voltage input, the VCC pin voltage starts rising.
- B: $V_{CC} > V_{UVLO1}$, the DC/DC operation starts
- C: $V_{CC} > V_{OVP1}$, the VCCOVP function is detected.
- D: $V_{CC} > V_{OVP1}$ continues T_{LATCH} (typ = 100us), switching is stopped by the VCCOVP function (LATCH MODE).
- E: $V_{CC} < V_{CHG1}$, the VCC charge function operates and the VCC voltage is rise.
- F: $V_{CC} > V_{CHG2}$, the VCC charge function is stopped.
- G: Same as E.
- H: Same as F.
- I: The V_H pin is OPEN. The VCC Voltage is fall.
- J: $V_{CC} < V_{UVLO2}$, the DC/DC operation stops
- K: $V_{CC} < V_{LATCH}$, the LATCH function is reset.

(3-2)VCC Charge function

The VCC charge function operates once the VCC pin $>V_{UVLO1}$ and the DC/DC operation starts then the VCC pin voltage drops to $<V_{CHG1}$. At that time the VCC pin is charged from the VH pin through the start up circuit. By this operation, BM1Pxxx doesn't occur to start failure. The VCC pin voltage is rise, then $VCC >V_{CHG2}$, charge is stopped. The operations are shown in figure 9.

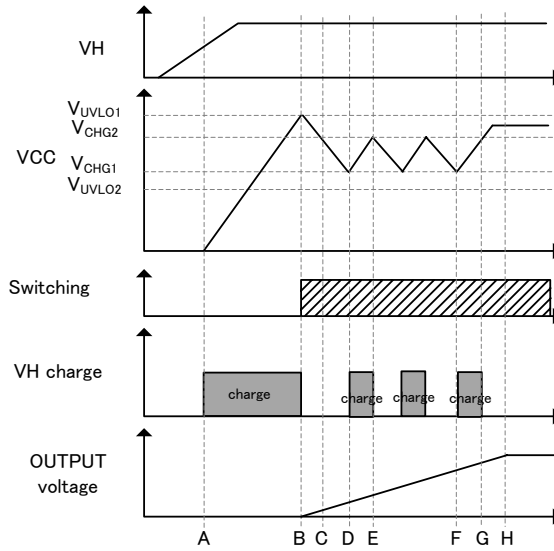

Figure 9. Charge operation VCC pin charge operation

- A: The VH pin voltage rises, the charge starts to the VCC pin by the VCC charge function.
- B: $VCC > V_{UVLO1}$, the VCC UVLO function releases, the VCC charge function stops, the DC/DC operation starts.
- C: When DC/DC operation starts, the VCC voltage drops.
- D: $VCC < V_{CHG1}$, the VCC recharge function operates.
- E: $VCC > V_{CHG2}$, the VCC recharge function stops.
- F: $VCC < V_{CHG1}$, the VCC recharge function operates.
- G: $VCC < V_{CHG1}$, the VCC recharge function stops.
- H: After a start of output voltage finished, the VCC Pin is charged by the auxiliary winding, then VCC pin stabilizes.

(4) DCDC driver (PWM comparator, frequency hopping, slope compensation, OSC, burst)

BM1Pxxx is a current mode PWM control.

An internal oscillator sets a fixed switching frequency.

BM1Pxxx is integrated the hopping function of the switching frequency which changes the switching frequency to fluctuate as shown in Figure 10.

The fluctuation cycle is 125 Hz typ.

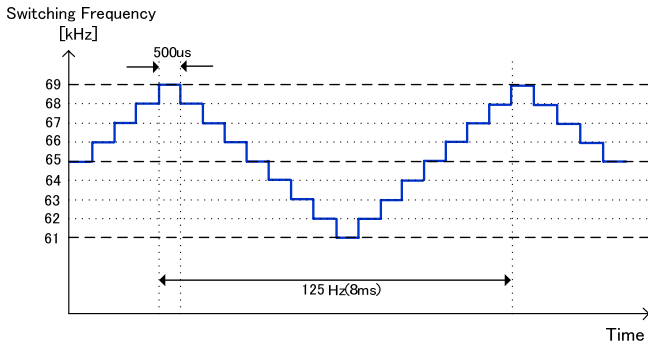

Figure 10-1. hopping function (BM1P06x series)

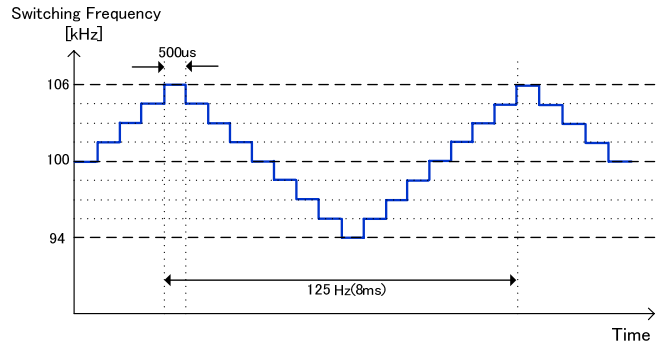

Figure 10-2. hopping function (BM1P10x series)

Max duty cycle is fixed as 75% (typ) and MIN pulse width is fixed as 400 ns (typ).

With the current mode control, when the duty cycle exceeds 50% sub harmonic oscillation may occur.

As a countermeasure to this, BM1Pxxx is built in slope compensation.

BM1Pxxx is built in the burst mode circuit and the frequency reduction circuit to achieve low power consumption, when the load is light.

The FB pin is pull up by R_{FB} (30 kΩ typ).

The FB pin voltage is changed by secondary output voltage (secondary load power).

To monitor the FB pin, the burst mode operation and the frequency detection is operated.

Figure 11 shows the FB voltage, the switching frequency and the DC/DC operation

- mode1 : the burst operation
- mode2: the frequency reduction operation. (reduce the max frequency)
- mode3 : the fixed frequency operation.(operate at the max frequency)
- mode4 : the over load operation.(detect the over load state and stop the pulse operation)

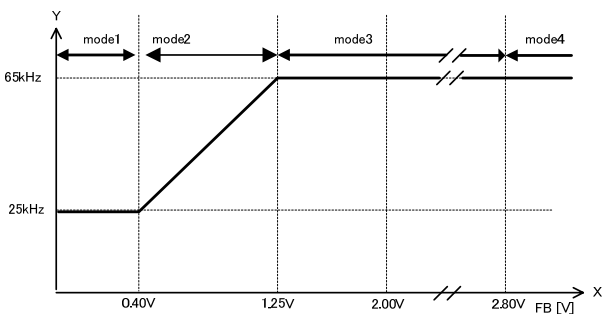

Figure-11-1. Switching operation state (BM1P06x series)

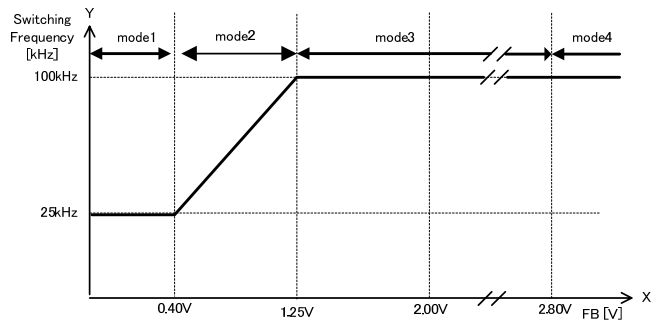

Figure-11-2. Switching operation state (BM1P10x series)

(5) Over Current limiter

BM1Pxxx is built in the Over Current limiter per cycle. If the CS pin is over a certain voltage, the switching is stopped. It is also built in the AC voltage compensation function. The function is rise over the current limiter level by time to compensate AC voltage.

Shown in figure-12,13,14

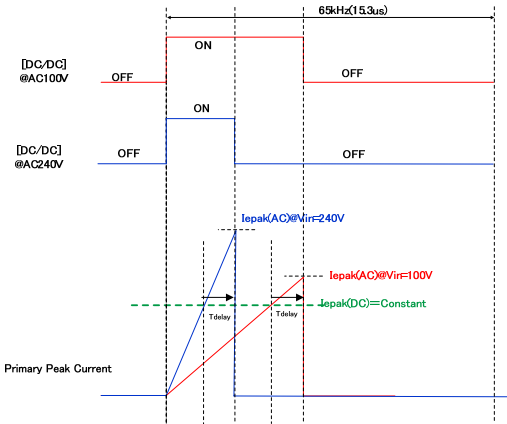

Figure 12. No AC voltage compensation function

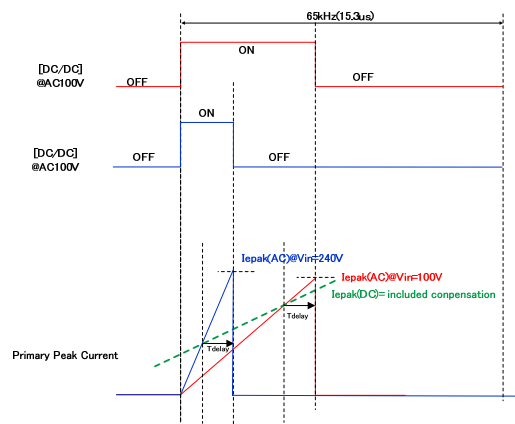

Figure 13. built-in AC compensation voltage

The primary peak current is decided as the formula below.

The primary peak current: $I_{peak} = V_{cs}/R_s + V_{dc}/L_p * T_{delay}$

V_{cs} : the over current limiter voltage

R_s : the current detection resistance

V_{dc} : the input DC voltage

L_p : the Primary inductance

T_{delay} : the delay time after the detection of the over current limiter

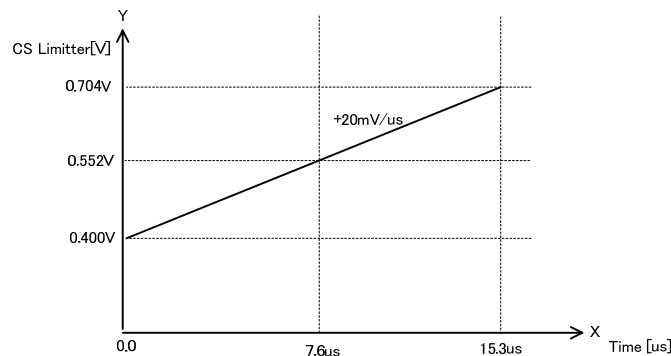

Figure 14. Over current limiter voltage

(6) L.E.B blanking period

When the driver MOSFET is turned ON, a surge current occurs at capacitor components and the drive current.

Therefore, because of rising the CS pin voltage temporarily, the detection errors may occur in the over current limiter circuit. To prevent detection errors, when the OUT pin is switched from high to low, the CS signal is masked for 250 ns by the on-chip LEB (Leading Edge Blanking) function. This blanking function reduces CS pin noise filter for the noise that occurs when the OUT pin is switched from high to low.

(7) CS pin (1pin) open protection

If the CS pin becomes OPEN, other IC may be damaged.
 To prevent this damage, BM1Pxxx built in the OPEN protection circuit(auto recovery protection).

(8) Output over load protection function (FB OLP Comparator)

The output overload protection monitors the secondary output load status at the FB pin.
 This function stops a switching when an overload occurs. When there is an overload, the output voltage is dropped and the photo coupler current becomes zero, so the FB pin voltage is rised.

When the FB pin voltage > V_{FOLP1A} (2.8 V typ) continuously for the period T_{FOLP2} (32 ms typ), it is judged as an overload and stops switching.

When the FB pin > V_{FOLP1A} (2.8 V typ), if the voltage goes lower than V_{FOLP1B} (2.6V typ) during the period T_{FOLP2} (32 ms typ), the overload protection timer is reset. The switching operation is performed during this period T_{FOLP2} (32ms typ)

At startup, the FB voltage is pulled up to the IC's internal voltage, so the operation starts at a voltage of V_{FOLP1A} (2.8 V typ) or above. Therefore, at startup the FB voltage must be set to go to V_{FOLP1B} (2.6 Vtyp) or below during the period T_{FOLP1} (32 ms typ), and the secondary output voltage's start time must be set within the period T_{FOLP2} (32 ms typ) following startup of the IC.

Recovery from the once detection of FBOLP, after the period T_{FOLP2} (512 ms typ)

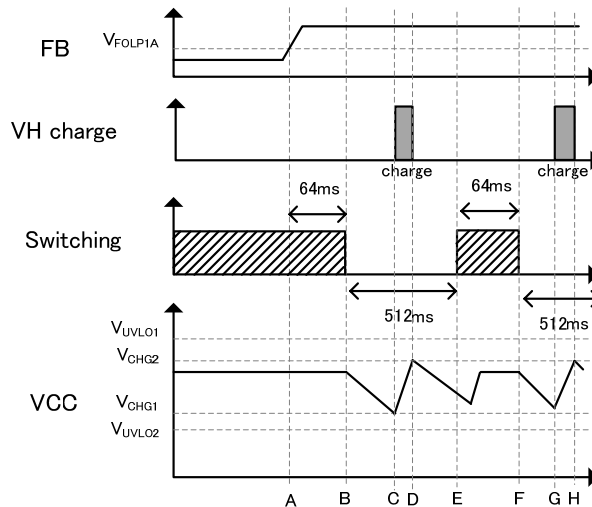

Figure 15. Over load protection (Auto recovery)

- A: The FBOLP comparator detects over load for $FB > V_{FOLP1A}$
- B: States of A continuously for the period T_{FOLP2} (32 ms typ), it is judged as an overload and stops switching.
- C: While switching stops for the over load protection function, the VCC pin voltage drops and VCC pin voltage reaches $< V_{CHG}$, the VCC charge function operates so the VCC pin voltage rises.
- D: VCC charge function stops when VCC pin voltage $> V_{CHG2}$
- E: If T_{OLPST} (typ =512ms) go on from B point, Switching function starts on soft start.
- F: If T_{FOLP2} (typ=32ms) go on from E point to continues a overload condition ($FB > V_{FOLP1A}$), Switching function stops at F point.
- G: While switching stops VCC pin voltage drops to $< V_{CHG1}$, VCC charge function operates and VCC pin voltage rises.
- H: If VCC pin (1pin) voltage becomes over V_{CHG2} by the VCC charge function, VCC charge function operation stops

(9) OUT Pin Voltage clamber

BM1Pxxx has a gate clamber function. It set the OUT pin high voltage to V_{OUTH} (typ=12.5V). It prevents the damage for MOSFET gate by the rising of VCC pin (6pin) voltage. (Shown in Figure16)

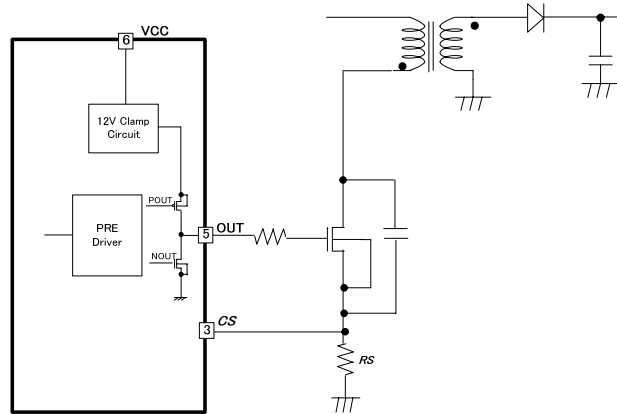

Figure 16. OUT pin (5pin) Block Diagram

(10) ACMONI Function

Brownout function is built inside BM1PXXX. Brownout function means that DC/DC action will stop when input AC voltage is low. Application example is shown in Figure 17. Input voltage is divided by resistance and input into ACMONI terminal. If voltage of ACMONI terminal exceeds $V_{ACMONI1}$ (1.0V typ), circuit will detect normal status and start to execute DC/DC action. After DC/DC action and voltage of ACMONI terminal is lower than $V_{ACMONI2}$ (0.7V typ), T_{ACMONI} (typ.256ms) later, DC/DC action becomes OFF.

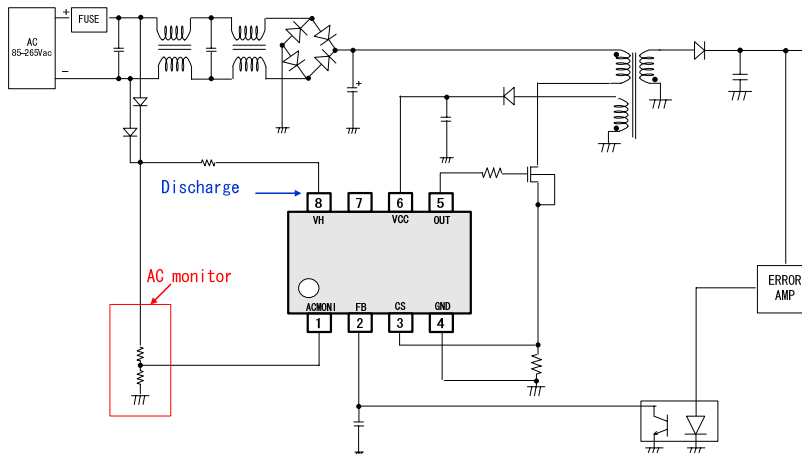

Figure 17. Application circuit

* If brownout function is not used, please set voltage value within the range of V_{ACMONI} (1.0Vtyp)~5.0V.

●Operation mode of protection circuit

Operation mode of protection functions are shown in table2.

Table 2. Operation mode of protection circuit

Function	Operation mode
VCC Under Voltage Locked Out	Auto recovery
VCC Over Voltage Protection	BM1Pxx1 series : Auto recovery (with 100us Timer) BM1Pxx2 series : Latch (with 100us Timer)
FB Over Limited Protection	Auto recovery (with 32ms timer)
CS Open Protection	Auto recovery

●Sequence

The sequence diagram is show in Figure 18 and Figure19
All condition transits OFF Mode $V_{CC} < 8.2V$

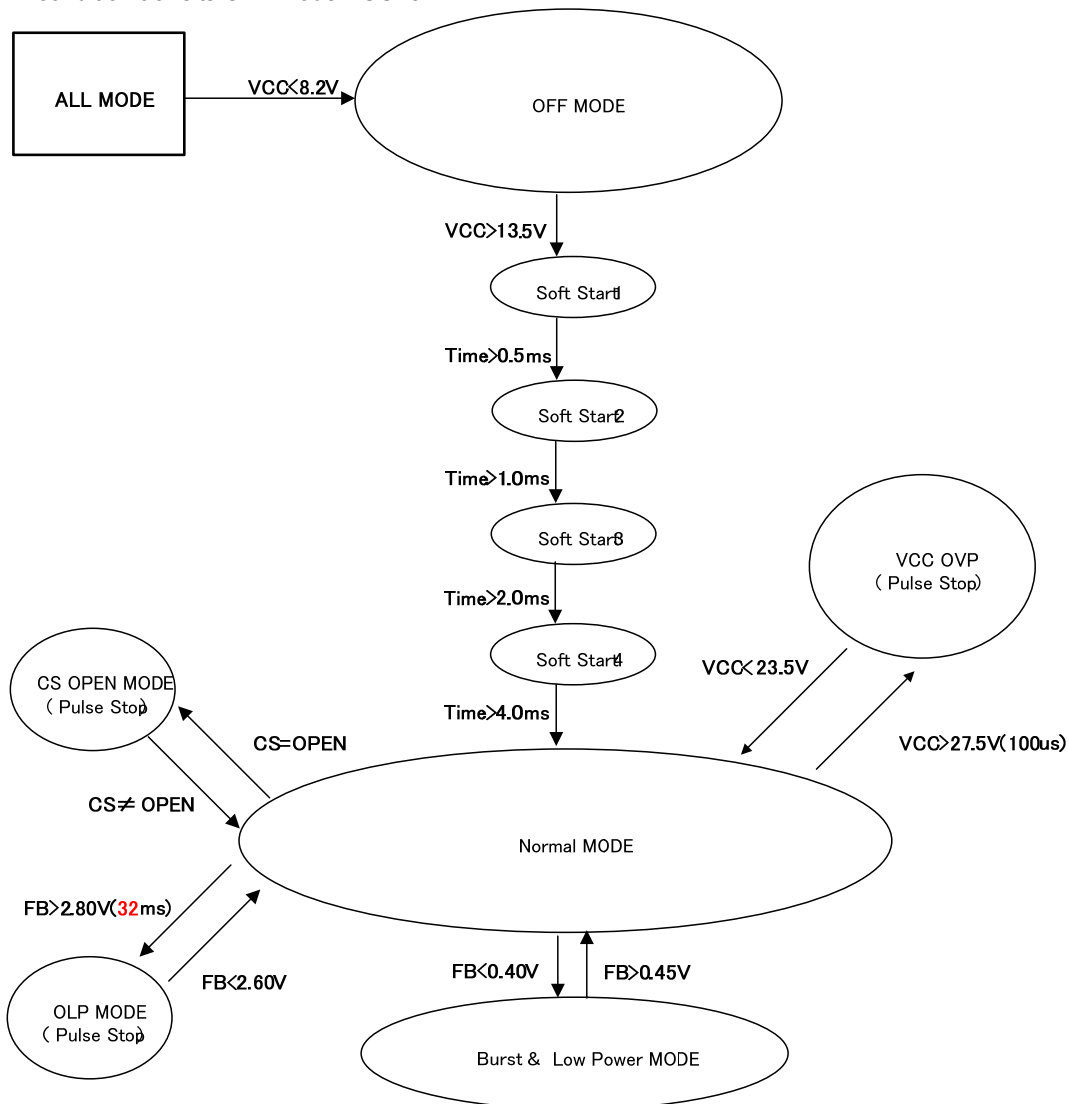

Figure 18. The sequence diagram (BM1PXX1 Series)

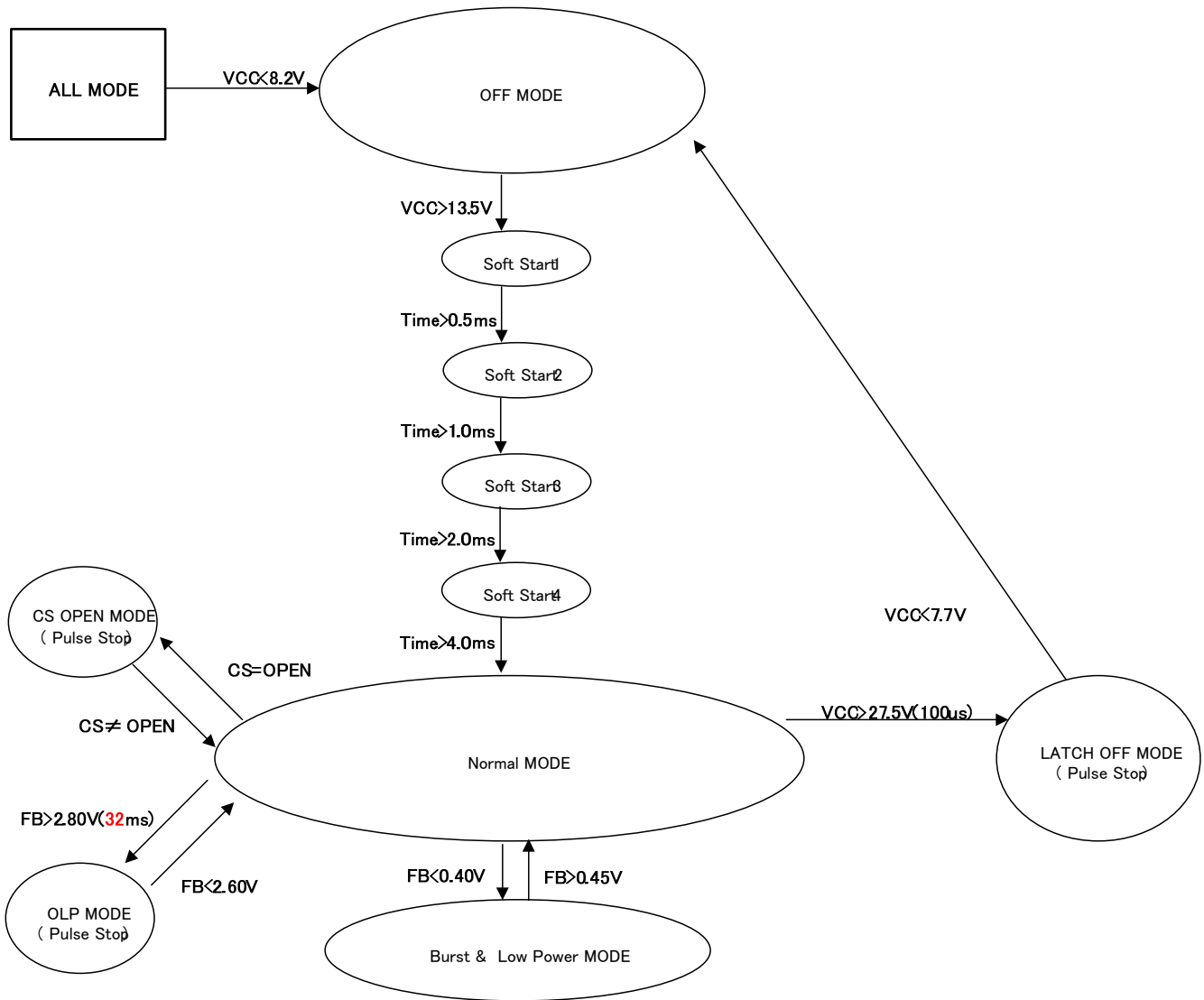

Figure 19. The sequence diagram(BM1PXX2 Series)

• **Thermal loss**

The thermal design should set operation for the following conditions.

(Since the temperature shown below is the guaranteed temperature, be sure to take a margin into account.)

1. The ambient temperature T_a must be 85°C or less.
2. The IC's loss must be within the allowable dissipation P_d .

The thermal abatement characteristics are as follows.

(PCB: 70 mm × 70 mm × 1.6 mm, mounted on glass epoxy substrate)

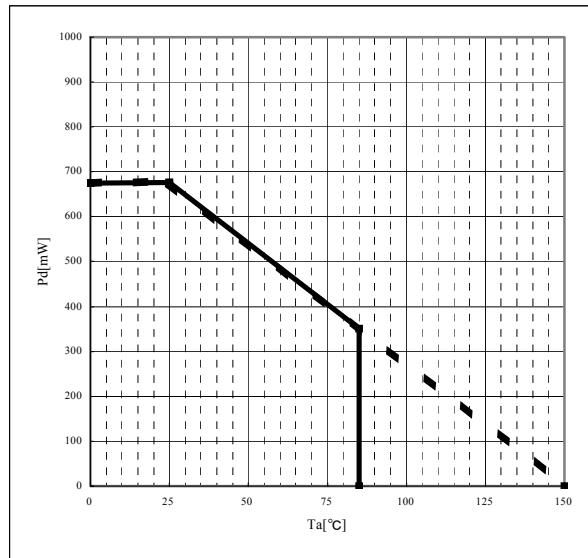

Figure 20. Thermal Abatement Characteristics

- Use-related cautions
- (1) Absolute maximum ratings

Damage may occur if the absolute maximum ratings such as for applied voltage or operating temperature range are exceeded, and since the type of damage (short, open circuit, etc.) cannot be determined, in cases where a particular mode that may exceed the absolute maximum ratings is considered, use of a physical safety measure such as a fuse should be investigated.
 - (2) Power supply and ground lines

In the board pattern design, power supply and ground lines should be routed so as to achieve low impedance. If there are multiple power supply and ground lines, be careful with regard to interference caused by common impedance in the routing pattern. With regard to ground lines in particular, be careful regarding the separation of large current routes and small signal routes, including the external circuits. Also, with regard to all of the LSI's power supply pins, in addition to inserting capacitors between the power supply and ground pins, when using capacitors there can be problems such as capacitance losses at low temperature, so check thoroughly as to whether there are any problems with the characteristics of the capacitor to be used before determining constants.
 - (3) Ground potential

The ground pin's potential should be set to the minimum potential in relation to the operation mode.
 - (4) Pin shorting and attachment errors

When attaching ICs to the set board, be careful to avoid errors in the IC's orientation or position. If such attachment errors occur, the IC may become damaged. Also, damage may occur if foreign matter gets between pins, between a pin and a power supply line, or between ground lines.
 - (5) Operation in strong magnetic fields

Note with caution that these products may become damaged when used in a strong magnetic field.
 - (6) Input pins

In IC structures, parasitic elements are inevitably formed according to the relation to potential. When parasitic elements are active, they can interfere with circuit operations, can cause operation faults, and can even result in damage. Accordingly, be careful to avoid use methods that enable parasitic elements to become active, such as when a voltage that is lower than the ground voltage is applied to an input pin. Also, do not apply voltage to an input pin when there is no power supply voltage being applied to the IC. In fact, even if a power supply voltage is being applied, the voltage applied to each input pin should be either below the power supply voltage or within the guaranteed values in the electrical characteristics.
 - (7) External capacitors

When a ceramic capacitor is used as an external capacitor, consider possible reduction to below the nominal capacitance due to current bias and capacitance fluctuation due to temperature and the like before determining constants.
 - (8) Thermal design

The thermal design should fully consider allowable dissipation (Pd) under actual use conditions.
Also, use these products within ranges that do not put output Tr beyond the rated voltage and ASO.
 - (9) Rush current

In a CMOS IC, momentary rush current may flow if the internal logic is undefined when the power supply is turned ON, so caution is needed with regard to the power supply coupling capacitance, the width of power supply and GND pattern wires, and how they are laid out.
 - (10) Handling of test pins and unused pins

Test pins and unused pins should be handled so as not to cause problems in actual use conditions, according to the descriptions in the function manual, application notes, etc. Contact us regarding pins that are not described.
 - (11) Document contents

Documents such as application notes are design documents used when designing applications, and as such their contents are not guaranteed. Before finalizing an application, perform a thorough study and evaluation, including for external parts.

Status of this document

The Japanese version of this document is formal specification. A customer may use this translation version only for a reference to help reading the formal version.

If there are any differences in translation version of this document formal version takes priority.

●Ordering Information

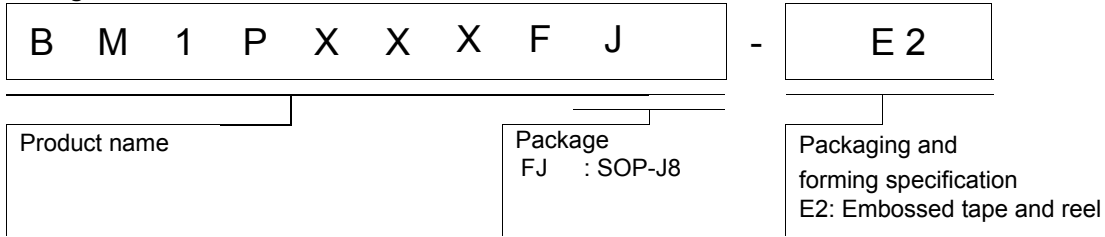

●Physical Dimension Tape and Reel Information

SOP-J8

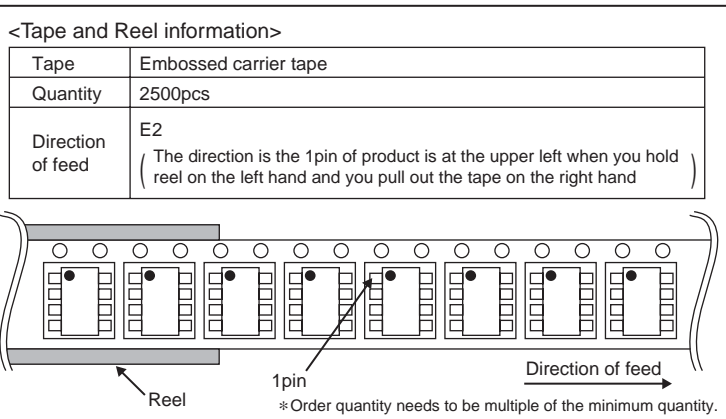
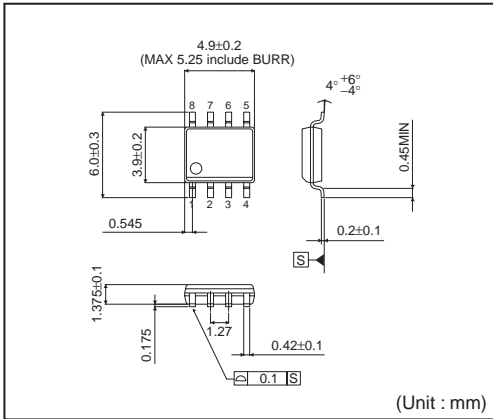

●Marking Diagram

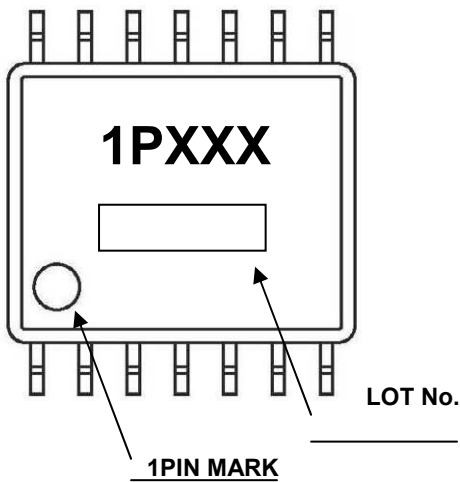

●Line-Up

Product name (BM1PXXXFJ)
BM1P101FJ
BM1P102FJ
BM1P061FJ
BM1P062FJ

Notice

●General Precaution

- 1) Before you use our Products, you are requested to carefully read this document and fully understand its contents. ROHM shall not be in any way responsible or liable for failure, malfunction or accident arising from the use of any ROHM's Products against warning, caution or note contained in this document.
- 2) All information contained in this document is current as of the issuing date and subject to change without any prior notice. Before purchasing or using ROHM's Products, please confirm the latest information with a ROHM sales representative.

●Precaution on using ROHM Products

- 1) Our Products are designed and manufactured for application in ordinary electronic equipments (such as AV equipment, OA equipment, telecommunication equipment, home electronic appliances, amusement equipment, etc.). If you intend to use our Products in devices requiring extremely high reliability (such as medical equipment, transport equipment, traffic equipment, aircraft/spacecraft, nuclear power controllers, fuel controllers, car equipment including car accessories, safety devices, etc.) and whose malfunction or failure may cause loss of human life, bodily injury or serious damage to property ("Specific Applications"), please consult with the ROHM sales representative in advance. Unless otherwise agreed in writing by ROHM in advance, ROHM shall not be in any way responsible or liable for any damages, expenses or losses incurred by you or third parties arising from the use of any ROHM's Products for Specific Applications.
- 2) ROHM designs and manufactures its Products subject to strict quality control system. However, semiconductor products can fail or malfunction at a certain rate. Please be sure to implement, at your own responsibilities, adequate safety measures including but not limited to fail-safe design against the physical injury, damage to any property, which a failure or malfunction of our Products may cause. The following are examples of safety measures:
 - [a] Installation of protection circuits or other protective devices to improve system safety
 - [b] Installation of redundant circuits to reduce the impact of single or multiple circuit failure
- 3) Our Products are designed and manufactured for use under standard conditions and not under any special or extraordinary environments or conditions, as exemplified below. Accordingly, ROHM shall not be in any way responsible or liable for any damages, expenses or losses arising from the use of any ROHM's Products under any special or extraordinary environments or conditions. If you intend to use our Products under any special or extraordinary environments or conditions (as exemplified below), your independent verification and confirmation of product performance, reliability, etc. prior to use, must be necessary:
 - [a] Use of our Products in any types of liquid, including water, oils, chemicals, and organic solvents
 - [b] Use of our Products outdoors or in places where the Products are exposed to direct sunlight or dust
 - [c] Use of our Products in places where the Products are exposed to sea wind or corrosive gases, including Cl₂, H₂S, NH₃, SO₂, and NO₂
 - [d] Use of our Products in places where the Products are exposed to static electricity or electromagnetic waves
 - [e] Use of our Products in proximity to heat-producing components, plastic cords, or other flammable items
 - [f] Sealing or coating our Products with resin or other coating materials
 - [g] Use of our Products without cleaning residue of flux (even if you use no-clean type fluxes, cleaning residue of flux is recommended); or Washing our Products by using water or water-soluble cleaning agents for cleaning residue after soldering
 - [h] Use of the Products in places subject to dew condensation
- 4) The Products are not subject to radiation-proof design.
- 5) Please verify and confirm characteristics of the final or mounted products in using the Products.
- 6) In particular, if a transient load (a large amount of load applied in a short period of time, such as pulse) is applied, confirmation of performance characteristics after on-board mounting is strongly recommended. Avoid applying power exceeding normal rated power; exceeding the power rating under steady-state loading condition may negatively affect product performance and reliability.
- 7) De-rate Power Dissipation (Pd) depending on Ambient temperature (Ta). When used in sealed area, confirm the actual ambient temperature.
- 8) Confirm that operation temperature is within the specified range described in the product specification.
- 9) ROHM shall not be in any way responsible or liable for failure induced under deviant condition from what is defined in this document.

●Precaution for Mounting / Circuit board design

- 1) When a highly active halogenous (chlorine, bromine, etc.) flux is used, the residue of flux may negatively affect product performance and reliability.
- 2) In principle, the reflow soldering method must be used; if flow soldering method is preferred, please consult with the ROHM representative in advance.

For details, please refer to ROHM Mounting specification

●Precautions Regarding Application Examples and External Circuits

- 1) If change is made to the constant of an external circuit, please allow a sufficient margin considering variations of the characteristics of the Products and external components, including transient characteristics, as well as static characteristics.
- 2) You agree that application notes, reference designs, and associated data and information contained in this document are presented only as guidance for Products use. Therefore, in case you use such information, you are solely responsible for it and you must exercise your own independent verification and judgment in the use of such information contained in this document. ROHM shall not be in any way responsible or liable for any damages, expenses or losses incurred by you or third parties arising from the use of such information.

●Precaution for Electrostatic

This Product is electrostatic sensitive product, which may be damaged due to electrostatic discharge. Please take proper caution in your manufacturing process and storage so that voltage exceeding the Products maximum rating will not be applied to Products. Please take special care under dry condition (e.g. Grounding of human body / equipment / solder iron, isolation from charged objects, setting of Ionizer, friction prevention and temperature / humidity control).

●Precaution for Storage / Transportation

- 1) Product performance and soldered connections may deteriorate if the Products are stored in the places where:
 - [a] the Products are exposed to sea winds or corrosive gases, including Cl₂, H₂S, NH₃, SO₂, and NO₂
 - [b] the temperature or humidity exceeds those recommended by ROHM
 - [c] the Products are exposed to direct sunshine or condensation
 - [d] the Products are exposed to high Electrostatic
- 2) Even under ROHM recommended storage condition, solderability of products out of recommended storage time period may be degraded. It is strongly recommended to confirm solderability before using Products of which storage time is exceeding the recommended storage time period.
- 3) Store / transport cartons in the correct direction, which is indicated on a carton with a symbol. Otherwise bent leads may occur due to excessive stress applied when dropping of a carton.
- 4) Use Products within the specified time after opening a humidity barrier bag. Baking is required before using Products of which storage time is exceeding the recommended storage time period.

●Precaution for Product Label

QR code printed on ROHM Products label is for ROHM's internal use only.

●Precaution for Disposition

When disposing Products please dispose them properly using an authorized industry waste company.

●Precaution for Foreign Exchange and Foreign Trade act

Since our Products might fall under controlled goods prescribed by the applicable foreign exchange and foreign trade act, please consult with ROHM representative in case of export.

●Precaution Regarding Intellectual Property Rights

- 1) All information and data including but not limited to application example contained in this document is for reference only. ROHM does not warrant that foregoing information or data will not infringe any intellectual property rights or any other rights of any third party regarding such information or data. ROHM shall not be in any way responsible or liable for infringement of any intellectual property rights or other damages arising from use of such information or data.:
- 2) No license, expressly or implied, is granted hereby under any intellectual property rights or other rights of ROHM or any third parties with respect to the information contained in this document.

●Other Precaution

- 1) The information contained in this document is provided on an "as is" basis and ROHM does not warrant that all information contained in this document is accurate and/or error-free. ROHM shall not be in any way responsible or liable for any damages, expenses or losses incurred by you or third parties resulting from inaccuracy or errors of or concerning such information.
- 2) This document may not be reprinted or reproduced, in whole or in part, without prior written consent of ROHM.
- 3) The Products may not be disassembled, converted, modified, reproduced or otherwise changed without prior written consent of ROHM.
- 4) In no event shall you use in any way whatsoever the Products and the related technical information contained in the Products or this document for any military purposes, including but not limited to, the development of mass-destruction weapons.
- 5) The proper names of companies or products described in this document are trademarks or registered trademarks of ROHM, its affiliated companies or third parties.