

Capacitive Controller ICs

# Capacitive Switch Controller ICs



## BU21072MUV / BU21078MUV

**●General Description**

BU21072MUV/BU21078MUV is a capacitive sensor controller for switch operation. In addition to a regular simple switch, support matrix switches which are arranged in the matrix sensors. If external noise and temperature drift are detected, the automatic self-calibration is operated. Include LED controller with PWM function.

**●Features**

- 10 capacitive sensor ports. (BU21072MUV)  
12 capacitive sensor ports. (BU21078MUV)
- Supported Matrix switches.  
Maximum 16 switches. (BU21072MUV)  
Maximum 36 switches. (BU21078MUV)
- Automatic self-calibration.
- Held touch detection.
- LED controller with PWM function.
- Inform the detected result of switch operation by interrupt.
- 2-wire serial bus interface.
- 3.3V single power supply.
- Built-in Power-On-Reset and Oscillator.

**●Applications**

- Appliance that require multiple switches.
- Information appliance as printer.
- AV appliance as digital TV and HDD recorder.
- Notebook PC.

**●Key Specifications**

- Input voltage range 3.0 to 3.6V (Typ.)
- Operating temperature range -25 to 85°C (Typ.)
- Operating current 3.5mA (Typ. without load)
- Scan rate 16msec (Typ.)

**●Packages**

BU21072MUV :	VQFN024V4040	4.00 mm×4.00 mm×1.00 mm
BU21078MUV :	VQFN028V5050	5.00 mm×5.00 mm×1.00 mm



VQFN024V4040



VQFN028V5050

**●Typical Application Circuit**

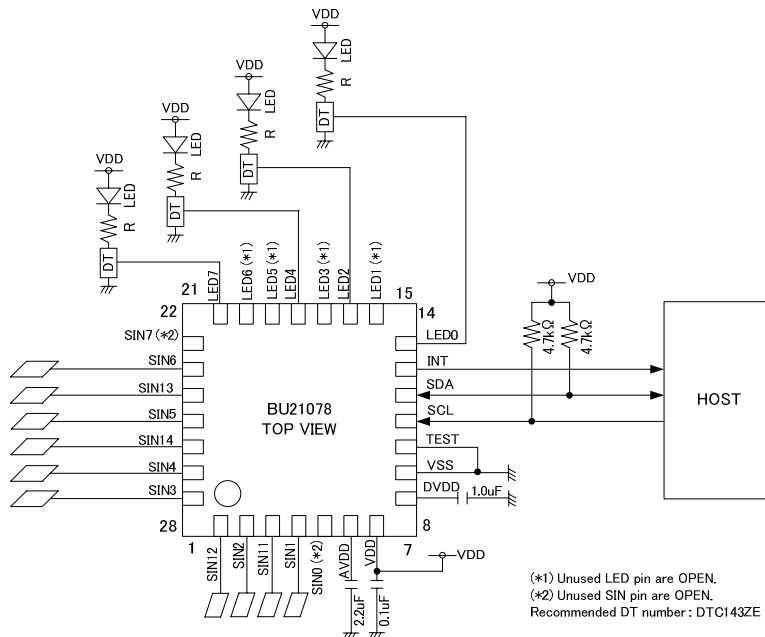

Fig.1 Typical Application Circuit

●Overview

BU21072MUV/BU21078MUV is a capacitive sensor controller for switch operation. Included blocks are AFE (Analog Front End) detecting capacitance, A/D converter, MPU, LED ports with PWM function, 2-wire serial bus interface compatible with I2C protocol, power-on-reset, oscillator. Operate with a 3.0 to 3.6V single power supply.

The results that detected switch operations (Touch/Release/Hold) are held to each register. An interrupt is send from INT port to the host when a register is updated by detected operations. If external noise and temperature drift are detected, run automatic self-calibration. Without periodical polling, offer the reduction of the host load.

LED ports are able to be applied PWM function. PWM function offers fade-in / fade-out brightness control.

●Simple switch

One sensor is assigned to one switch. Each simple switch has the registers of detected Touch/Release/Hold operations. Simple switches support to multi-detect Touch/Release/Hold. Unused simple switches are maskable.

●Matrix switches

The cross points of the sensors which are arranged in a matrix are able to assigned to individual switches. Each matrix switch has the registers of detected Touch/Release/Hold operations. Matrix switches do not support to multi-detect Touch/Release/Hold. Not used matrix switches are maskable. BU21072MUV supports 16 matrix switches configured by 4x4 sensors, and BU21078MUV supports 36 matrix switches configured by 6x6 sensors.

●Automatic self-calibration

BU21072MUV/BU21078MUV has observed the situation surrounding the sensor based on the detection result. If external noise and temperature drift are detected, the automatic self-calibration is operated for the stable detection result.

●LED controller with PWM timers

LED controller is High active. Each LED port is assigned to a choice of four PWM timers. If the situation surrounding the sensor is changed by the switching LED, it is useable that calibration is operated by sending LED control command.

●Host interface

BU21072MUV/BU21078MUV is slave device for the host device. 2-wire serial bus is compatible with I2C protocol. Slave Address : 0x5C(BU21072MUV) , 0x5D(BU21078MUV)

●Pin Configurations

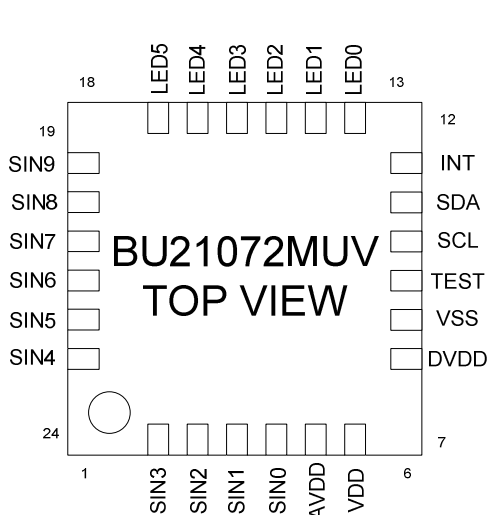

Fig.2 Pin configuration of BU21072MUV

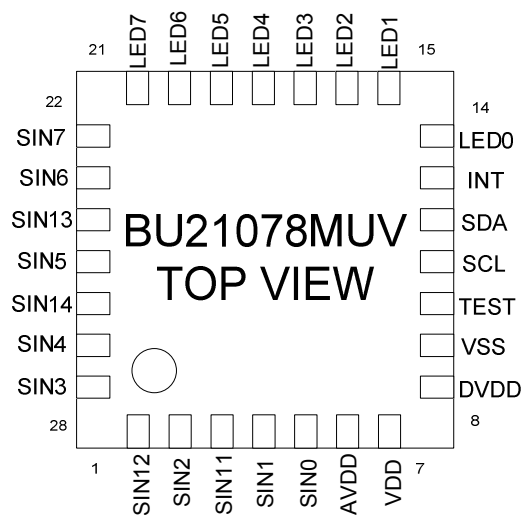

Fig.3 Pin configuration of BU21078MUV

● Pin Descriptions

Number		Name	Type	Function	Note	Power	Initial Condition	I/O Equivalence Circuit
BU21072MUV	BU21078MUV							
-	1	SIN12	Ain	Capacitive Touch Sensor 12		AVDD	Hi-Z	Fig.4
2	2	SIN2	Ain	Capacitive Touch Sensor 2		AVDD	Hi-Z	Fig.4
-	3	SIN11	Ain	Capacitive Touch Sensor 11		AVDD	Hi-Z	Fig.4
3	4	SIN1	Ain	Capacitive Touch Sensor 1		AVDD	Hi-Z	Fig.4
4	5	SIN0	Ain	Capacitive Touch Sensor 0		AVDD	Hi-Z	Fig.4
5	6	AVDD	Power	LDO output for analog blocks		VDD	-	-
6	7	VDD	Power	Power		-	-	-
7	8	DVDD	Power	LDO output for digital blocks		VDD	-	-
8	9	VSS	GND	Ground		-	-	-
9	10	TEST	In	Test input	Must be tied to Ground	VDD	-	Fig.5
10	11	SCL	InOut	Host I/F clock input		VDD	Hi-Z	Fig.5
11	12	SDA	InOut	Bi-directional Host I/F Data		VDD	Hi-Z	Fig.5
12	13	INT	Out	Interrupt output	Active High Interrupt	VDD	"L"	Fig.6
13	14	LED0	Out	LED control with PWM output 0	Active High	VDD	Hi-Z	Fig.6
14	15	LED1	Out	LED control with PWM output 1	Active High	VDD	Hi-Z	Fig.6
15	16	LED2	Out	LED control with PWM output 2	Active High	VDD	Hi-Z	Fig.6
16	17	LED3	Out	LED control with PWM output 3	Active High	VDD	Hi-Z	Fig.6
17	18	LED4	Out	LED control with PWM output 4	Active High	VDD	Hi-Z	Fig.6
18	19	LED5	Out	LED control with PWM output 5	Active High	VDD	Hi-Z	Fig.6
-	20	LED6	Out	LED control with PWM output 6	Active High	VDD	"L"	Fig.6
-	21	LED7	Out	LED control with PWM output 7	Active High	VDD	"L"	Fig.6
19	-	SIN9	Ain	Capacitive Touch Sensor 9		AVDD	Hi-Z	Fig.4
20	-	SIN8	Ain	Capacitive Touch Sensor 8		AVDD	Hi-Z	Fig.4
21	22	SIN7	Ain	Capacitive Touch Sensor 7		AVDD	Hi-Z	Fig.4
22	23	SIN6	Ain	Capacitive Touch Sensor 6		AVDD	Hi-Z	Fig.4
-	24	SIN13	Ain	Capacitive Touch Sensor 13		AVDD	Hi-Z	Fig.4
23	25	SIN5	Ain	Capacitive Touch Sensor 5		AVDD	Hi-Z	Fig.4
-	26	SIN14	Ain	Capacitive Touch Sensor 14		AVDD	Hi-Z	Fig.4
24	27	SIN4	Ain	Capacitive Touch Sensor 4		AVDD	Hi-Z	Fig.4
1	28	SIN3	Ain	Capacitive Touch Sensor 3		AVDD	Hi-Z	Fig.4

Initial Condition is at that power-on-reset is active.

● I/O Equivalence Circuits

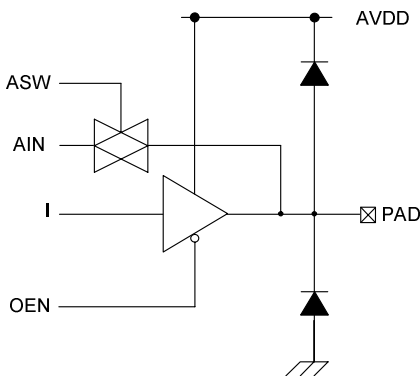

Fig.4 I/O equivalence circuit (a)

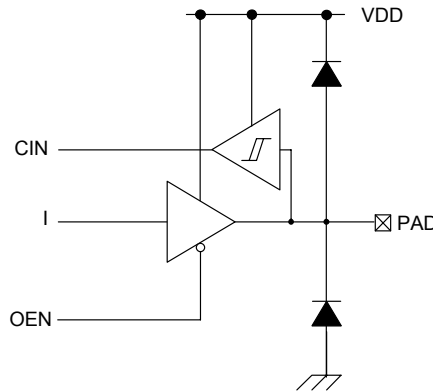

Fig.5 I/O equivalence circuit (b)

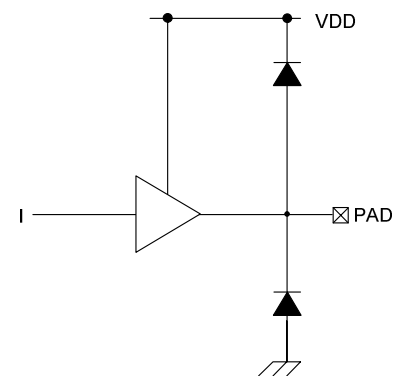

Fig.6 I/O equivalence circuit (c)

●Block Diagram

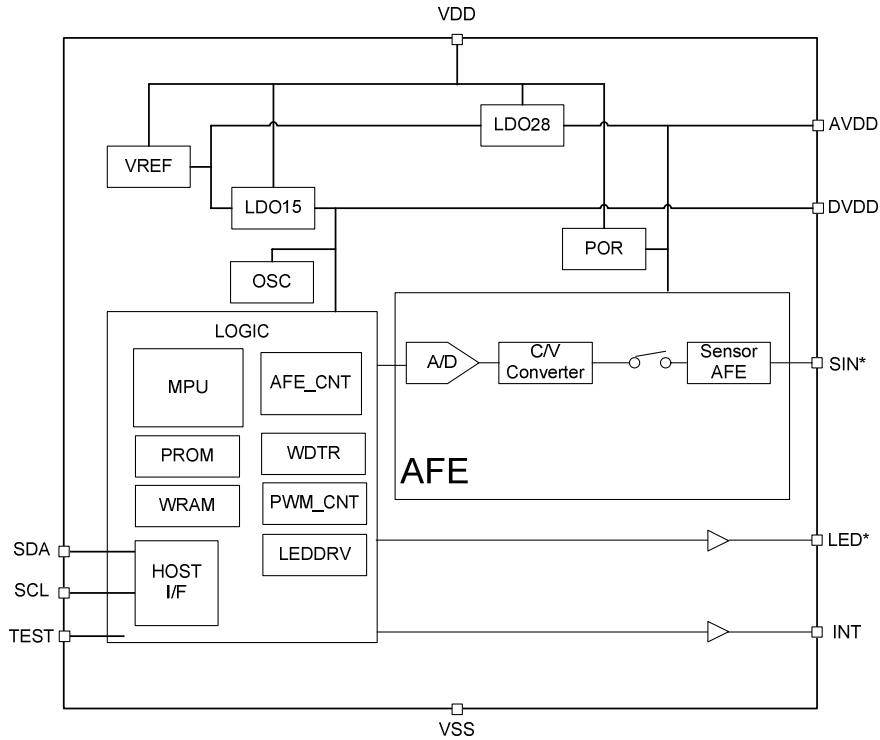

Fig.7 Block Diagram

●Description of Blocks

- Sensor AFE, C/V Converter  
Convert from capacitance to voltage following the order of sensors.
- A/D  
Convert from voltage to the detected result the digital value.
- LDO28  
2.73V output LDO for Sensor AFE, C/V Converter and A/D.
- LDO15  
1.5V output LDO for OSC and digital blocks.
- OSC  
Ring oscillator as the system clock.
- POR  
Power-On-Reset monitoring VDD as the system reset.
- MPU  
Based on the detection result, detect switch operations (Touch/Release/Hold) and run Auto-calibration. Inform by the INT port to the host about that the switch operations are detected. Control LED ports by the commands from the host.
- PROM  
Program ROM for the included MPU.
- WRAM  
Work RAM for the included MPU.
- HOST I/F  
2-wire serial bus interface compatible with I2C protocol.
- AFE\_CNT  
Sequencer of Sensor AFE, C/V converter and A/D.
- PWM\_CNT  
PWM timers for the LED ports.
- LEDDRV  
LED port drivers.
- WDTR  
Watchdog Timer Reset. It releases the system reset after 1 sec from that MPU cannot clear WDTR. (If MPU cannot clear WDTR, MPU is hang-up.)

**● Absolute Maximum Ratings (Ta = 25°C)**

Parameter		Symbol	Rating	Unit
Power supply voltage		VDD	-0.5 to 7.0	V
Input voltage		V <sub>IN</sub>	-0.5 to VDD + 0.3	V
Storage temperature range		T <sub>stg</sub>	-55 to 125	°C
Power dissipation	BU21072MUV	P <sub>d</sub>	272 <sup>*1</sup>	mW
	BU21078MUV		304 <sup>*2</sup>	
Maximum junction temperature		T <sub>jmax</sub>	125	°C

\*1 Derated by 2.72mW/°C over 25°C. (IC only).

\*2 Derated by 3.04mW/°C over 25°C. (IC only).

**● Recommended Operating Ratings**

Parameter		Symbol	Rating	Unit
Power supply voltage		VDD	3.0 to 3.6	V
Operating temperature range		T <sub>opr</sub>	-20 to 85	°C

**● Electrical Characteristics (Ta = 25°C , VDD = 3.3V , VSS = 0V)**

Parameter	Symbol	Rating			Unit	Condition
		Min.	Typ.	Max.		
Input High voltage	V <sub>IH</sub>	VDD x 0.7	-	VDD + 0.3	V	
Input Low voltage	V <sub>IL</sub>	VSS - 0.3	-	VDD x 0.3	V	
Output High voltage	V <sub>OH</sub>	VDD - 0.5	-	VDD	V	I <sub>OH</sub> = -4mA
Output Low voltage	V <sub>OL</sub>	VSS	-	VSS + 0.5	V	I <sub>OL</sub> = 4mA
Oscillator clock frequency	f <sub>OSC</sub>	45	50	55	MHz	
DVDD LDO output voltage	V <sub>DVDD</sub>	1.35	1.50	1.65	V	
AVDD LDO output voltage	V <sub>AVDD</sub>	2.63	2.73	2.83	V	
Power-on-reset release voltage		2.25	-	2.55	V	
Power-on-reset detect voltage		2.10	-	2.40	V	
Operating current	I <sub>DD</sub>	-	3.5	-	mA	Without load of sensors.

●Timing Charts

●Host interface

2-wire serial bus.  
 Compatible with I2C protocol.  
 Supports slave mode only.  
 Slave Address = 0x5C (BU21072MUV)  
 Slave Address = 0x5D (BU21078MUV)  
 Supports Standard-mode (data transfer rate of 100 kbit/s) and Fast-mode (data transfer rate of 400 kbit/s).  
 Supports sequential read.

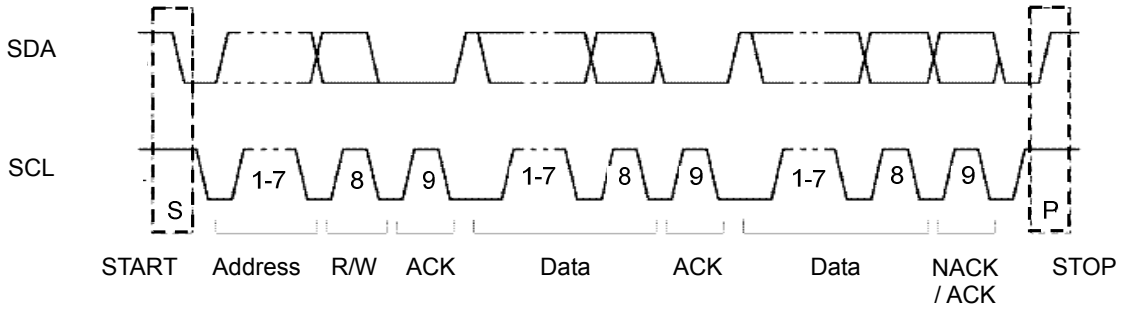

Fig.8 2-wire serial bus data format

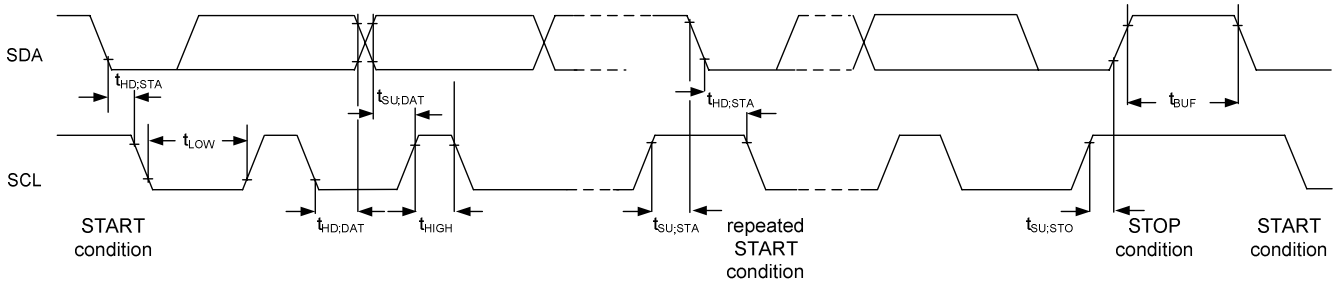
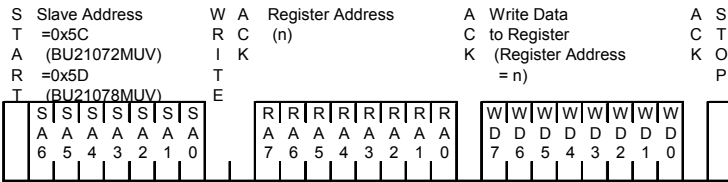

Fig.9 2-wire serial bus timing chart

Parameter	Symbol	Standard-mode		Fast-mode		Unit
		MIN	MAX	MIN	MAX	
Hold time (repeated) START condition	$f_{SCL}$	0	100	0	400	kHz
LOW period of the SCL clock	$t_{HD:STA}$	4.0	-	0.6	-	usec
HIGH period of the SCL clock	$t_{LOW}$	4.7	-	1.3	-	usec
Data hold time	$t_{HIGH}$	4.0	-	0.6	-	usec
Data set-up time	$t_{HD:DAT}$	0.1	3.45	0.1	0.9	usec
Set-up time for a repeated START condition	$t_{SU:DAT}$	0.25	-	0.1	-	usec
Set-up time for STOP condition	$t_{SU:STA}$	4.7	-	0.6	-	usec
Bus free time between a STOP and START condition	$t_{SU:STO}$	4.0	-	0.6	-	usec
Hold time (repeated) START condition	$t_{BUF}$	4.7	-	1.3	-	usec

●Byte Write



SA : Slave Address  
 RA : Register Address  
 RD : Read Data  
 WD : Write Data

●Random Read

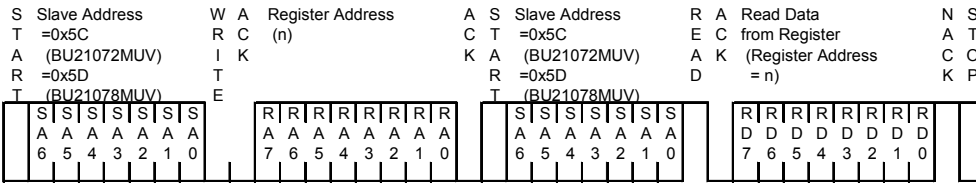

●Sequential Read

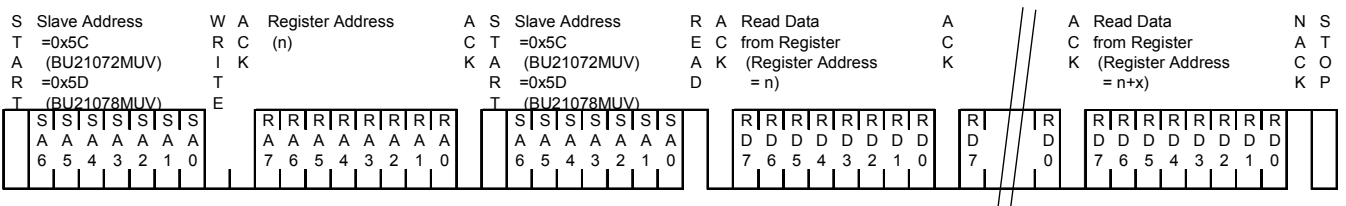

Fig.10 2-wire serial bus protocol

●Scan rate

After scan each sensor in time series, MPU convert to the switch operations from the detected results. The number of sensor ports is difference between BU21072MUV and BU21078MUV, but one scan rate is the same. One scan rate is about 16msec at typical.

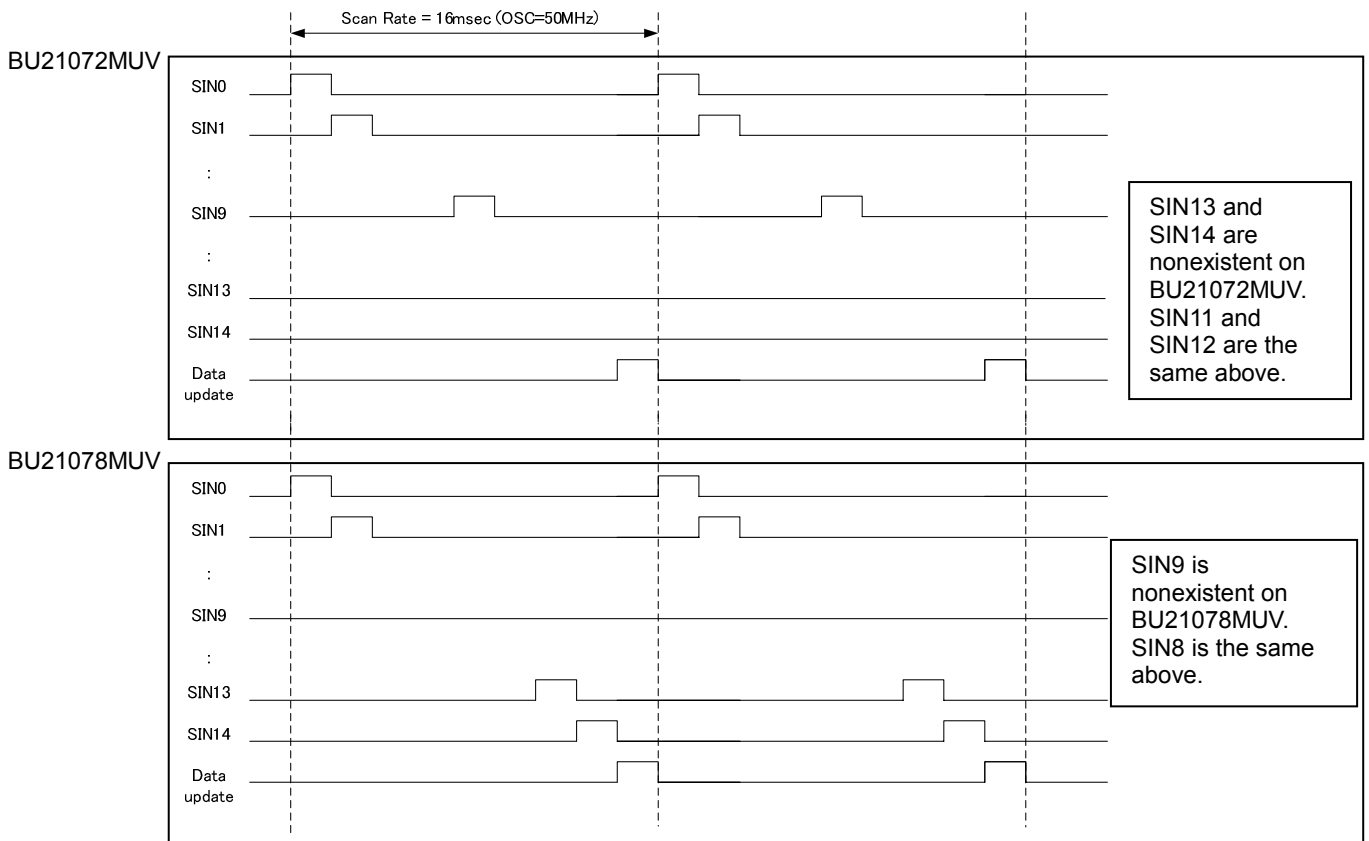

Fig.11 Timing chart of scan rate

•Power on sequence

Power supply pin is VDD only. AVDD and DVDD are supplied by each LDO included BU21072/78MUV, so that have no priority about power on sequence. When VDD reaches to the effective voltage, power-on-reset which initializes the digital block is released.  
 Power-On-Reset monitoring VDD, so it should be set to proper value of decoupling capacitor and VDD rise time, so as to rise to the proper voltage (DVDD→VDD).

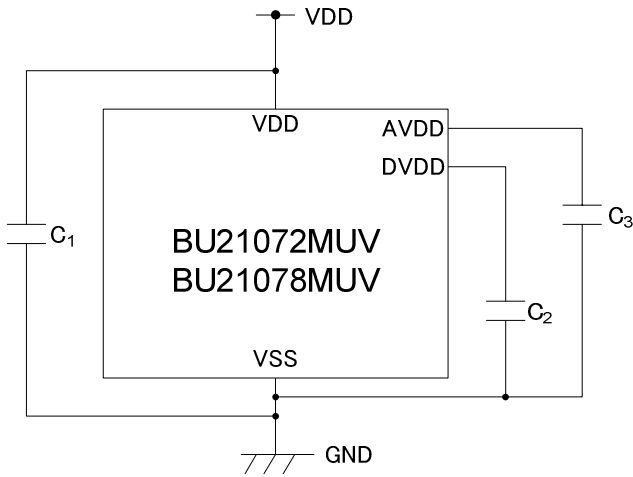

Fig.12 Arrangement of external decoupling capacitors

Recommended value of external capacitors

C1	0.1uF	VDD decoupling capacitor
C2	1.0uF	DVDD decoupling capacitor
C3	2.2uF	AVDD decoupling capacitor

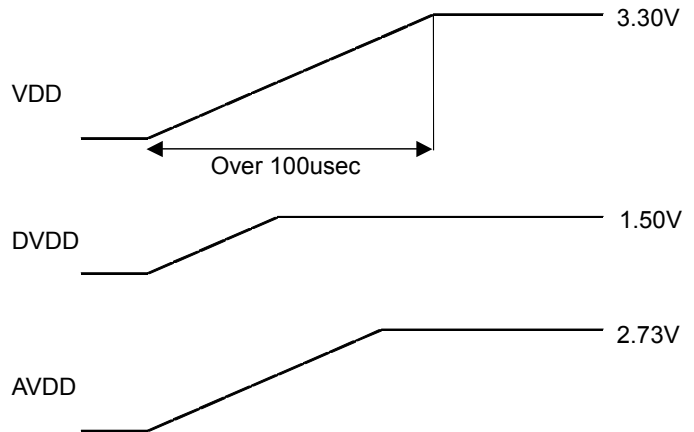

Fig.13 Timing chart of power on sequence

When power-on-reset is released, MPU starts initial sequence. Inform by the INT port to the host that the initialization has been completed. After verify that the initialization has completed, the host will need to resend the command to the IC.  
 In the case that WDTR is released as well, MPU starts initial sequence. If WDTR has released, all registers have been initialized. So the host will need to resend the command to the IC.

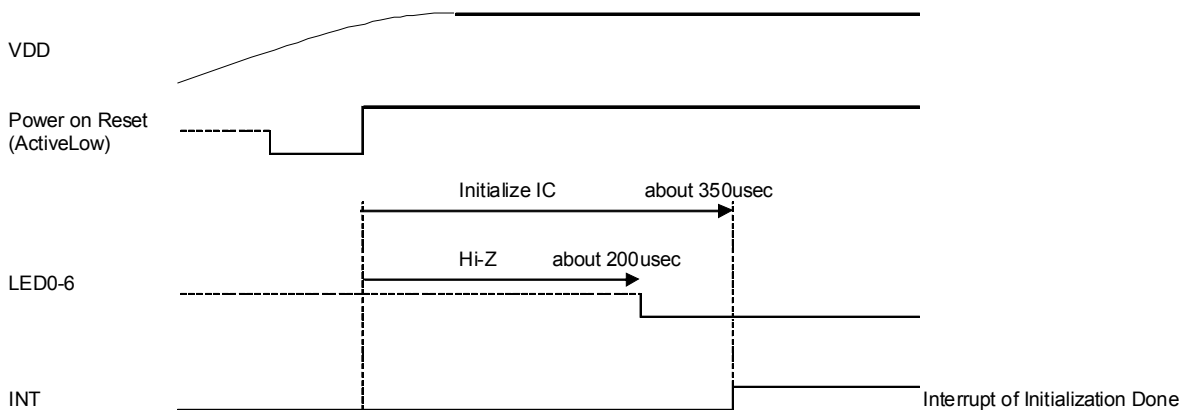

Fig.14 Timing chart of initialization

●Application Examples

BU21072MUV /BU21078MUV offer two method of switch. One is simple switch, another is matrix switch. The number of the maximum matrix switches is 16 by BU21072MUV, and 36 by BU21078MUV. LED ports are able to be applied PWM function. PWM function offers fade-in / fade-out brightness control.

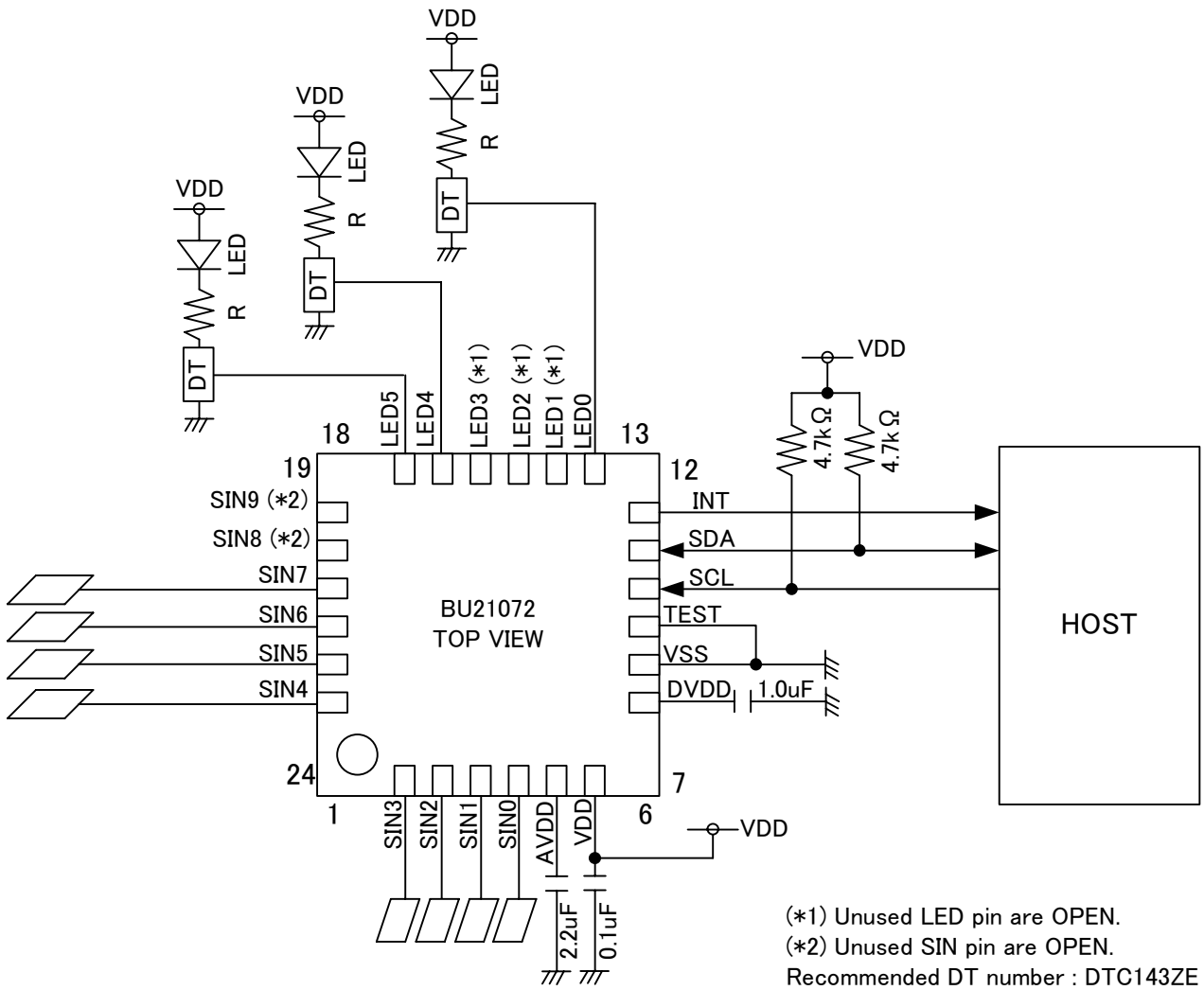

Fig.15 Application example 1 (8-simple switches, 3-LEDs with BU21072MUV)

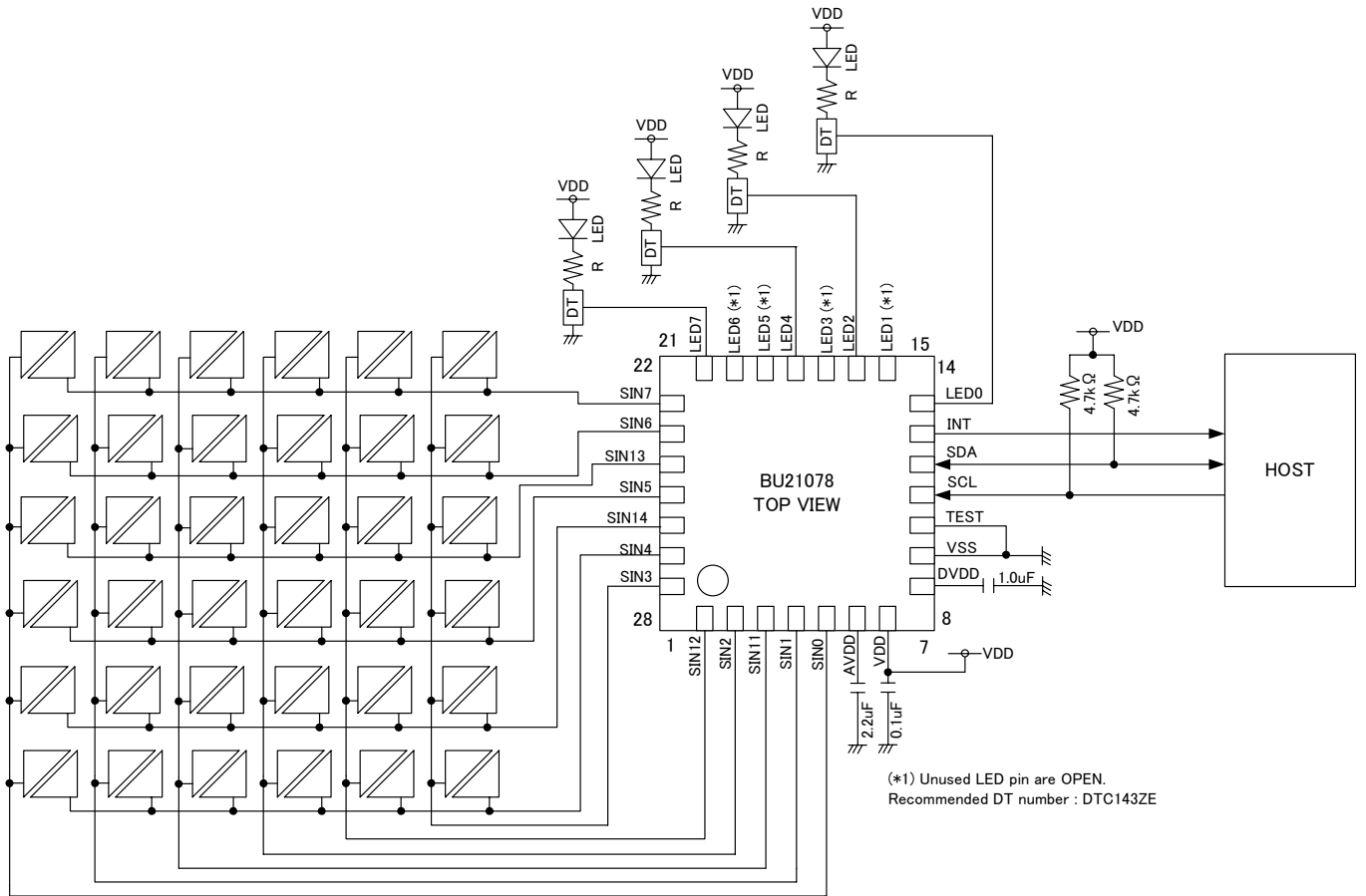

Fig.16 Application example 2 (36-matrix switches, 4-LEDs with BU21078MUV)

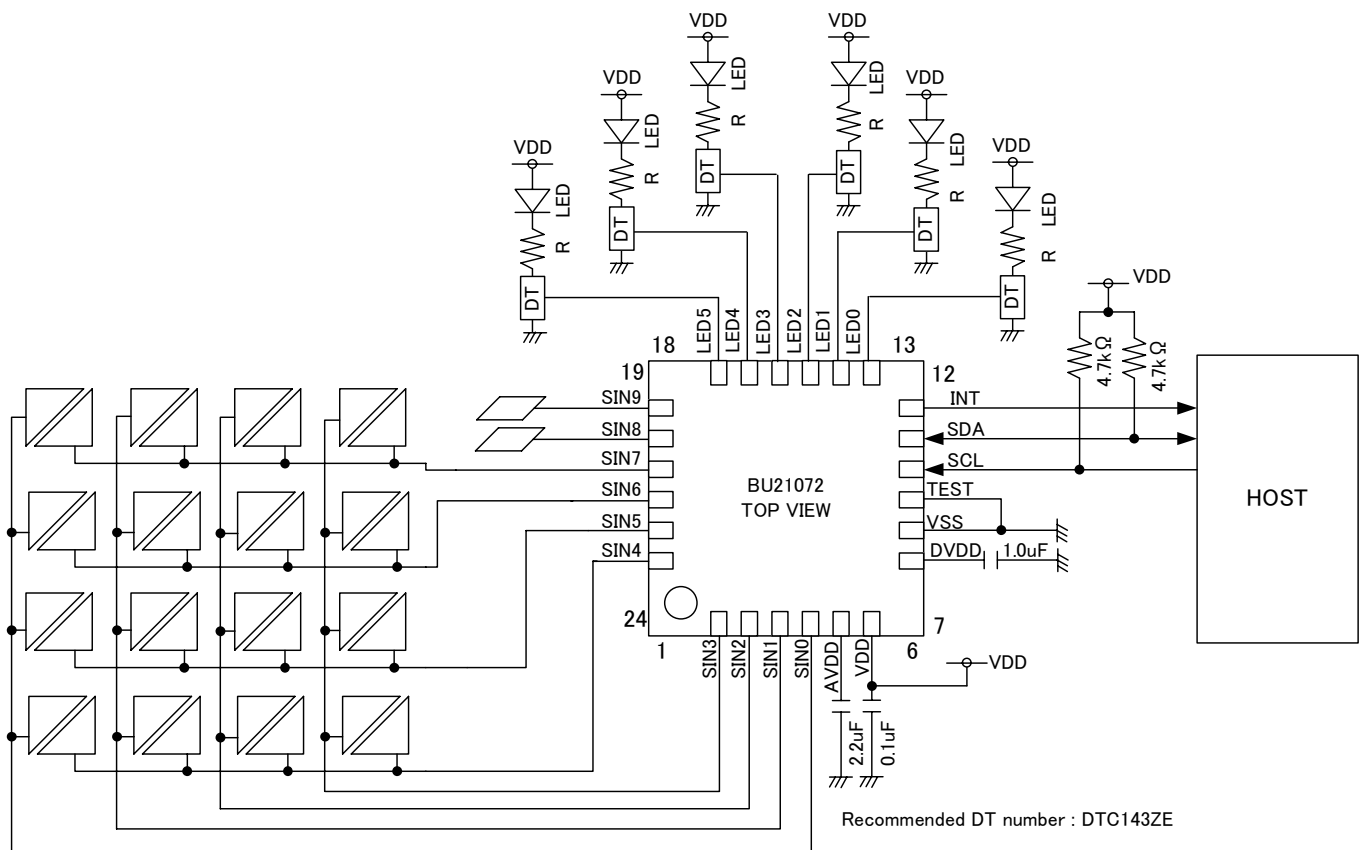

Fig.17 Application example 3 (16-matrix switches, 2-simple switches, 6-LEDs with BU21072MUV)

**●Operational Notes**

## (1) Absolute Maximum Ratings

An excess in the absolute maximum ratings, such as supply voltage, temperature range of operating conditions, etc., can break down devices, thus making impossible to identify breaking mode such as a short circuit or an open circuit. If any special mode exceeding the absolute maximum ratings is assumed, consideration should be given to take physical safety measures including the use of fuses, etc.

## (2) Operating conditions

These conditions represent a range within which characteristics can be provided approximately as expected. The electrical characteristics are guaranteed under the conditions of each parameter.

## (3) Reverse connection of power supply connector

The reverse connection of power supply connector can break down ICs. Take protective measures against the breakdown due to the reverse connection, such as mounting an external diode between the power supply and the IC's power supply terminal.

## (4) Power supply line

Design PCB pattern to provide low impedance for the wiring between the power supply and the GND lines. In this regard, for the digital block power supply and the analog block power supply, even though these power supplies has the same level of potential, separate the power supply pattern for the digital block from that for the analog block, thus suppressing the diffraction of digital noises to the analog block power supply resulting from impedance common to the wiring patterns. For the GND line, give consideration to design the patterns in a similar manner. Furthermore, for all power supply terminals to ICs, mount a capacitor between the power supply and the GND terminal. At the same time, in order to use an electrolytic capacitor, thoroughly check to be sure the characteristics of the capacitor to be used present no problem including the occurrence of capacity dropout at a low temperature, thus determining the constant.

## (5) GND voltage

Make setting of the potential of the GND terminal so that it will be maintained at the minimum in any operating state. Furthermore, check to be sure no terminals are at a potential lower than the GND voltage including an actual electric transient.

## (6) Short circuit between terminals and erroneous mounting

In order to mount ICs on a set PCB, pay thorough attention to the direction and offset of the ICs. Erroneous mounting can break down the ICs. Furthermore, if a short circuit occurs due to foreign matters entering between terminals or between the terminal and the power supply or the GND terminal, the ICs can break down.

## (7) Operation in strong electromagnetic field

Be noted that using ICs in the strong electromagnetic field can malfunction them.

## (8) Inspection with set PCB

On the inspection with the set PCB, if a capacitor is connected to a low-impedance IC terminal, the IC can suffer stress. Therefore, be sure to discharge from the set PCB by each process. Furthermore, in order to mount or dismount the set PCB to/from the jig for the inspection process, be sure to turn OFF the power supply and then mount the set PCB to the jig. After the completion of the inspection, be sure to turn OFF the power supply and then dismount it from the jig. In addition, for protection against static electricity, establish a ground for the assembly process and pay thorough attention to the transportation and the storage of the set PCB.

## (9) Input terminals

In terms of the construction of IC, parasitic elements are inevitably formed in relation to potential. The operation of the parasitic element can cause interference with circuit operation, thus resulting in a malfunction and then breakdown of the input terminal. Therefore, pay thorough attention not to handle the input terminals, such as to apply to the input terminals a voltage lower than the GND respectively, so that any parasitic element will operate. Furthermore, do not apply a voltage to the input terminals when no power supply voltage is applied to the IC. In addition, even if the power supply voltage is applied, apply to the input terminals a voltage lower than the power supply voltage or within the guaranteed value of electrical characteristics.

(10) Ground wiring pattern

If small-signal GND and large-current GND are provided, It will be recommended to separate the large-current GND pattern from the small-signal GND pattern and establish a single ground at the reference point of the set PCB so that resistance to the wiring pattern and voltage fluctuations due to a large current will cause no fluctuations in voltages of the small-signal GND. Pay attention not to cause fluctuations in the GND wiring pattern of external parts as well.

(11) External capacitor

In order to use a ceramic capacitor as the external capacitor, determine the constant with consideration given to a degradation in the nominal capacitance due to DC bias and changes in the capacitance due to temperature, etc.

(12) Rush current

The IC with some power supplies has a capable of rush current due to procedure and delay at power-on. Pay attention to the capacitance of the coupling capacitors and the wiring pattern width and routing of the power supply and the GND lines.

**Status of this document**

**The Japanese version of this document is formal specification. A customer may use this translation version only for a reference to help reading the formal version.**

**If there are any differences in translation version of this document formal version takes priority.**

●Ordering Information

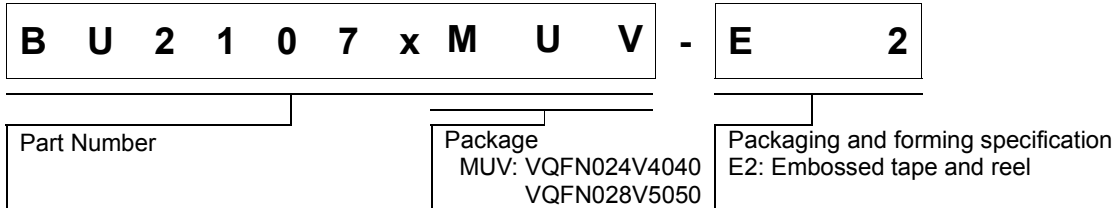

●Line-up

Sensor ports	Package	Orderable Part Number
10ch	VQFN024V4040	BU21072MUV-E2
12ch	VQFN028V5050	BU21078MUV-E2

●Physical Dimension Tape and Reel Information

VQFN024V4040

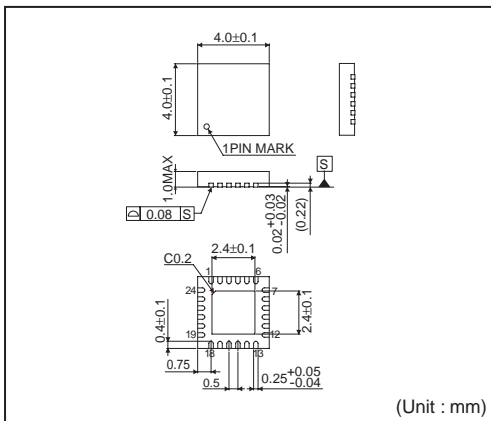

<Tape and Reel information>

Tape	Embossed carrier tape
Quantity	2500pcs
Direction of feed	E2 (The direction is the 1pin of product is at the upper left when you hold reel on the left hand and you pull out the tape on the right hand)

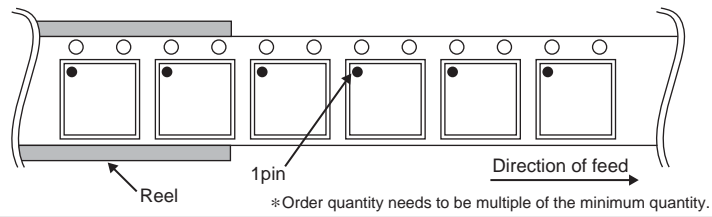

VQFN028V5050

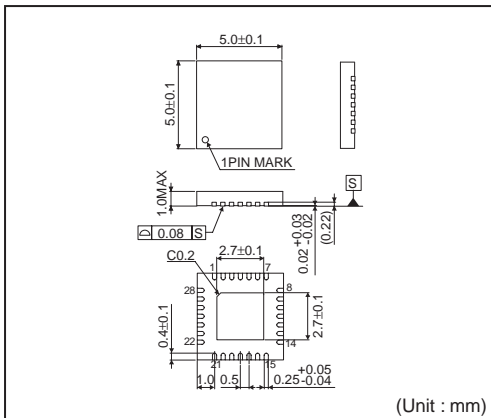

<Tape and Reel information>

Tape	Embossed carrier tape
Quantity	2500pcs
Direction of feed	E2 (The direction is the 1pin of product is at the upper left when you hold reel on the left hand and you pull out the tape on the right hand)

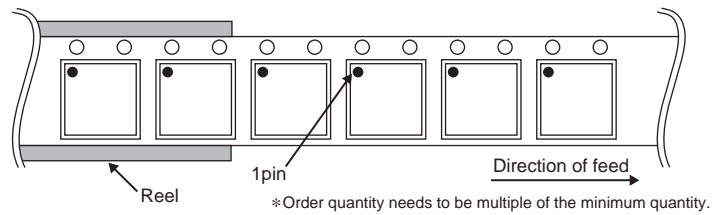

● Marking Diagrams (TOP VIEW)

VQFN024V4040 (TOP VIEW)

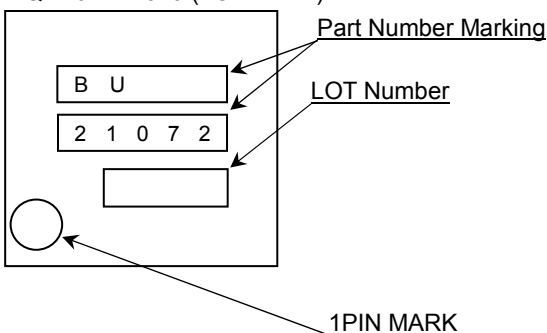

VQFN028V5050 (TOP VIEW)

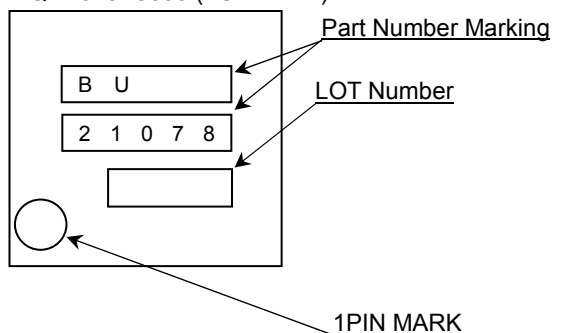

## ●Revision History

Date	Revision	Changes
12.Mar.2012	001	New Release

# Notice

## ●General Precaution

- 1) Before you use our Products, you are requested to carefully read this document and fully understand its contents. ROHM shall not be in any way responsible or liable for failure, malfunction or accident arising from the use of any ROHM's Products against warning, caution or note contained in this document.
- 2) All information contained in this document is current as of the issuing date and subject to change without any prior notice. Before purchasing or using ROHM's Products, please confirm the latest information with a ROHM sales representative.

## ●Precaution on using ROHM Products

- 1) Our Products are designed and manufactured for application in ordinary electronic equipments (such as AV equipment, OA equipment, telecommunication equipment, home electronic appliances, amusement equipment, etc.). If you intend to use our Products in devices requiring extremely high reliability (such as medical equipment, transport equipment, traffic equipment, aircraft/spacecraft, nuclear power controllers, fuel controllers, car equipment including car accessories, safety devices, etc.) and whose malfunction or failure may cause loss of human life, bodily injury or serious damage to property ("Specific Applications"), please consult with the ROHM sales representative in advance. Unless otherwise agreed in writing by ROHM in advance, ROHM shall not be in any way responsible or liable for any damages, expenses or losses incurred by you or third parties arising from the use of any ROHM's Products for Specific Applications.
- 2) ROHM designs and manufactures its Products subject to strict quality control system. However, semiconductor products can fail or malfunction at a certain rate. Please be sure to implement, at your own responsibilities, adequate safety measures including but not limited to fail-safe design against the physical injury, damage to any property, which a failure or malfunction of our Products may cause. The following are examples of safety measures:
  - [a] Installation of protection circuits or other protective devices to improve system safety
  - [b] Installation of redundant circuits to reduce the impact of single or multiple circuit failure
- 3) Our Products are designed and manufactured for use under standard conditions and not under any special or extraordinary environments or conditions, as exemplified below. Accordingly, ROHM shall not be in any way responsible or liable for any damages, expenses or losses arising from the use of any ROHM's Products under any special or extraordinary environments or conditions. If you intend to use our Products under any special or extraordinary environments or conditions (as exemplified below), your independent verification and confirmation of product performance, reliability, etc. prior to use, must be necessary:
  - [a] Use of our Products in any types of liquid, including water, oils, chemicals, and organic solvents
  - [b] Use of our Products outdoors or in places where the Products are exposed to direct sunlight or dust
  - [c] Use of our Products in places where the Products are exposed to sea wind or corrosive gases, including Cl<sub>2</sub>, H<sub>2</sub>S, NH<sub>3</sub>, SO<sub>2</sub>, and NO<sub>2</sub>
  - [d] Use of our Products in places where the Products are exposed to static electricity or electromagnetic waves
  - [e] Use of our Products in proximity to heat-producing components, plastic cords, or other flammable items
  - [f] Sealing or coating our Products with resin or other coating materials
  - [g] Use of our Products without cleaning residue of flux (even if you use no-clean type fluxes, cleaning residue of flux is recommended); or Washing our Products by using water or water-soluble cleaning agents for cleaning residue after soldering
  - [h] Use of the Products in places subject to dew condensation
- 4) The Products are not subject to radiation-proof design.
- 5) Please verify and confirm characteristics of the final or mounted products in using the Products.
- 6) In particular, if a transient load (a large amount of load applied in a short period of time, such as pulse) is applied, confirmation of performance characteristics after on-board mounting is strongly recommended. Avoid applying power exceeding normal rated power; exceeding the power rating under steady-state loading condition may negatively affect product performance and reliability.
- 7) De-rate Power Dissipation (Pd) depending on Ambient temperature (Ta). When used in sealed area, confirm the actual ambient temperature.
- 8) Confirm that operation temperature is within the specified range described in the product specification.
- 9) ROHM shall not be in any way responsible or liable for failure induced under deviant condition from what is defined in this document.

**●Precaution for Mounting / Circuit board design**

- 1) When a highly active halogenous (chlorine, bromine, etc.) flux is used, the residue of flux may negatively affect product performance and reliability.
- 2) In principle, the reflow soldering method must be used; if flow soldering method is preferred, please consult with the ROHM representative in advance.

For details, please refer to ROHM Mounting specification

**●Precautions Regarding Application Examples and External Circuits**

- 1) If change is made to the constant of an external circuit, please allow a sufficient margin considering variations of the characteristics of the Products and external components, including transient characteristics, as well as static characteristics.
- 2) You agree that application notes, reference designs, and associated data and information contained in this document are presented only as guidance for Products use. Therefore, in case you use such information, you are solely responsible for it and you must exercise your own independent verification and judgment in the use of such information contained in this document. ROHM shall not be in any way responsible or liable for any damages, expenses or losses incurred by you or third parties arising from the use of such information.

**●Precaution for Electrostatic**

This Product is electrostatic sensitive product, which may be damaged due to electrostatic discharge. Please take proper caution in your manufacturing process and storage so that voltage exceeding the Products maximum rating will not be applied to Products. Please take special care under dry condition (e.g. Grounding of human body / equipment / solder iron, isolation from charged objects, setting of Ionizer, friction prevention and temperature / humidity control).

**●Precaution for Storage / Transportation**

- 1) Product performance and soldered connections may deteriorate if the Products are stored in the places where:
  - [a] the Products are exposed to sea winds or corrosive gases, including Cl<sub>2</sub>, H<sub>2</sub>S, NH<sub>3</sub>, SO<sub>2</sub>, and NO<sub>2</sub>
  - [b] the temperature or humidity exceeds those recommended by ROHM
  - [c] the Products are exposed to direct sunshine or condensation
  - [d] the Products are exposed to high Electrostatic
- 2) Even under ROHM recommended storage condition, solderability of products out of recommended storage time period may be degraded. It is strongly recommended to confirm solderability before using Products of which storage time is exceeding the recommended storage time period.
- 3) Store / transport cartons in the correct direction, which is indicated on a carton with a symbol. Otherwise bent leads may occur due to excessive stress applied when dropping of a carton.
- 4) Use Products within the specified time after opening a humidity barrier bag. Baking is required before using Products of which storage time is exceeding the recommended storage time period.

**●Precaution for Product Label**

QR code printed on ROHM Products label is for ROHM's internal use only.

**●Precaution for Disposition**

When disposing Products please dispose them properly using an authorized industry waste company.

**●Precaution for Foreign Exchange and Foreign Trade act**

Since our Products might fall under controlled goods prescribed by the applicable foreign exchange and foreign trade act, please consult with ROHM representative in case of export.

**●Precaution Regarding Intellectual Property Rights**

- 1) All information and data including but not limited to application example contained in this document is for reference only. ROHM does not warrant that foregoing information or data will not infringe any intellectual property rights or any other rights of any third party regarding such information or data. ROHM shall not be in any way responsible or liable for infringement of any intellectual property rights or other damages arising from use of such information or data.:
- 2) No license, expressly or implied, is granted hereby under any intellectual property rights or other rights of ROHM or any third parties with respect to the information contained in this document.

●Other Precaution

- 1) The information contained in this document is provided on an "as is" basis and ROHM does not warrant that all information contained in this document is accurate and/or error-free. ROHM shall not be in any way responsible or liable for any damages, expenses or losses incurred by you or third parties resulting from inaccuracy or errors of or concerning such information.
- 2) This document may not be reprinted or reproduced, in whole or in part, without prior written consent of ROHM.
- 3) The Products may not be disassembled, converted, modified, reproduced or otherwise changed without prior written consent of ROHM.
- 4) In no event shall you use in any way whatsoever the Products and the related technical information contained in the Products or this document for any military purposes, including but not limited to, the development of mass-destruction weapons.
- 5) The proper names of companies or products described in this document are trademarks or registered trademarks of ROHM, its affiliated companies or third parties.