

Built-in OVP Micro USB Switch with USB2.0, MHL™ and Audio



BD91411GW

● **General Description**

BD91411GW is USB connector interface IC. It is possible to use it for the application for the mobile device such as smart phones and mobile phones.

● **Features**

- Complete solution for mini/micro USB connect multiplexing.
- MHL/USB/UART 2paths, AUDIO 1path, Monaural Microphone 1path in 4 to 1 multiplexer.
- Compatible with USB High Speed/Full Speed.
- CECBUS to ID bypass switch.
- Audio switch handle with negative voltage signal.
- Microphone signal paths to VBUS or HDPR are built in.
- ID resistance support to CEA936A, Battery Charging Specification (BCS) ver1.2, MCPC, USB-OTG and MHL specification.
- Power-On Reset.
- USB Charger detection support with BCS ver1.2 specification.
- Over voltage protection (OVP) up to 28V about VB(VBUS) input and VC(cradle) input.
- Power multiplexer OVP input about VB and VC.
- Internal Low Ron FET about OVP(VB and VC).
- OTG power path switch (Output side in this power path support 28V protection) is built in.
- VBUS linked LDO (4.9V or 3.3V are selectable.)
- I²C compatible Interface.

● **Key Specifications**

- OVP switch ON resistance: 120mΩ (Typ.)
- Over Current Protection(OC): 2.0A(Min.)
- Regulator output voltage: 3.3V or 4.9V
- MHL/USB switch ON resistance: 5Ω (Typ.)
- MHL/USB switch ON capacitance: 6pF(Typ.)
- VBAT standby current: 6μA (Typ.)
- Operating temperature range: -30°C to +85°C

● **Applications**

- Mobile-Phones · Smart-Phones
- Tablet-PC
- Digital still camera (DSC)

● **Package**

UCSP75M3

W(Typ.) x D(Typ.) x H(Max.)
3.00mm x 3.00mm x 0.85mm

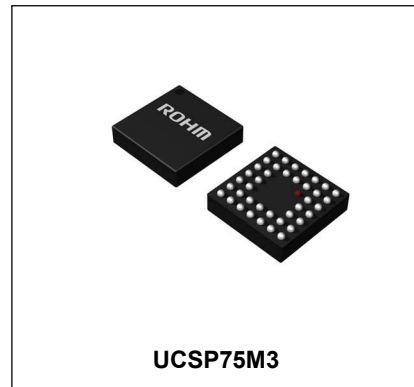

● **Typical Application Circuit**

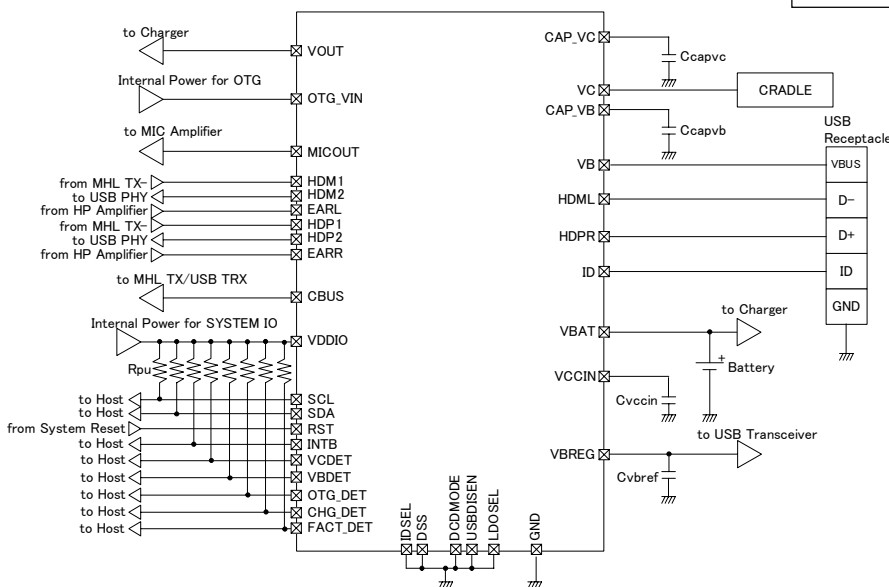

Fig.1 Typical Application Circuit

◆ Contents

1.Pin Configuration	3
2.Pin Description.....	3
3.Block Diagram	4
4.Absolute Maximum Ratings	5
5.Recommended Operating Ratings.....	5
6.Electrical Characteristic	6
7. Features.....	10
7-1.Pull down resistance detection in ID pin.....	10
7-1-1. Priority of MHLSW and ID detection.....	10
7-1-2. Application with SEND/END switch.detection.....	10
7-1-2-1. OTG Application Detection	10
7-1-2-2. MHL Application Detection.....	10
7-1-3. Enable for ID pin pull down resistance detection.....	10
7-1-4. Retry of ID detection sequence.....	10
7-1-5. Polling mode of ID detection sequence.....	10
7-1-6. Remove ID pin pull down resistance. (Application detachment).....	10
7-2. USB port detection.....	10
7-2-1. Data Contact Detect/DCD	10
7-2-2. Configuration of DCD time out.....	10
7-2-3. Primary Detection.....	10
7-2-4. Secondary Detection	10
7-2-5. Shortening of second detection by Enumeration preparation.....	11
7-2-6. Sequence Retrying.....	11
7-2-7. Deactivation of USB port detection by External PIN and Internal Register.....	11
7-3. Signal paths	11
7-3-1. HDPR/HDML Signal paths	11
7-3-2. Configuration of MUXSW initial path by DSS PIN.....	11
7-3-3. Pull-down resistance in EARR/RARL pin.....	11
7-3-4. Signal path between ID pin and CBUS pin.....	11
7-4. Interrupt report with INTB pin.....	11
7-4-1. Active level selector of INTB.....	11
7-4-2. Interrupt polarity.....	11
7-5. Detection of Cradle and VBUS by VBDET pin and VCDET pin.....	11
7-6. Detection of Cradle and VBUS by I2C interface reading.....	11
7-7. Detection of Over current state by I2C Interface reading.....	11
7-8. Thermal Shut down.....	11
7-9. VBREG Regulator.....	11
7-10. OTG mode control.....	12
7-11. VBUS signal path.....	12
7-12. Reset systems	12
7-12-1. Power-On Reset.....	12
7-12-2. Hardware Reset with RST.....	12
7-12-3. Software reset from I2C Interface writing.....	12
7-13. I ² C Interface electrical characteristics.....	12
7-14. I ² C Bus Interface.....	13
7-14-1. START and STOP Conditions	13
7-14-2. Modifiyng Data.....	13
7-14-3. Acknowledge	14
7-14-4. Device Address	14
7-14-5. Write operaton.....	15
7-14-6. Address roll back specification.....	15
7-14-7. Read back operation.....	15
8.Typical Performance Curves.....	16
9.Application Circuit Diagram.....	17
10.I/O equivalence circuits.....	18
11.Operational Notes	22
12.Ordering Information	23
13.Physical Dimension Tape and Reel Information.....	23
14.Marking Diagram	23
15.Revision History.....	24

1.Pin Configuration

G	TMODE1	HDM1	HDP1	EARL	EARR	ID	TMODE0
F	HDML	HDM2	HDP2	FACT_DET	CBUS	VCCIN	VDDIO
E	HDPR	MICOUT	DSS	RST	SCL	SDA	VBAT
D	GND	LDOSEL	CHG_DET	USBDISEN	DCDMODE	INTB	GND
C	VBREG	OTG_DET	(INDEX)	VBDET	VCDET	IDSEL	VC
B	OTG_VIN	VB	CAP_VB	VOUT	VOUT	VC	VC
A	ATEST0	VB	VB	VOUT	VOUT	CAP_VC	ATEST1
	1	2	3	4	5	6	7

Fig.2 Pin configuration (BOTTOM VIEW)

2.Pin Description

No.	BALL No.	BALL NAME	I/O	Function	pull down	Pins configuration when not in use
1	B6,B7,C7	VC	I	Power supply about Cradle input		open or GND
2	A2,A3,B2	VB	I	Power supply about USB VBUS input		open or GND
3	E7	VBAT	I	Power supply about Battery Voltage		open or GND
4	F7	VDDIO	I	Power supply for I2C I/F		open or GND
5	F6	VCCIN	O	Power supply for internal circuit		open
6	D1,D7	GND	GND	GND		GND
7	A4,A5,B4,B5	VOUT	O	OVP output		open
8	B1	OTG_VIN	I	OTG Power Input		open or GND
9	E3	DSS	I	MUXSW Initial Value Select Signal.		GND
10	A6	CAP_VC	O	CAP connect pin for SW1 OVP		open
11	B3	CAP_VB	O	CAP connect pin for SW2 OVP		open
12	C5	VCDET	O	VC detecting (UVLO < VC < OVLO)		open
13	C4	VBDET	O	VB detecting (UVLO < VB < OVLO)		open
14	C2	OTG_DET	O	OTG Mode Detection		open
15	F4	FACT_DET	O	Factory Mode Detection		open
16	F5	CBUS	I/O	CBUS Signal Path		open
17	C1	VBREG	O	Regulator with VBUS Output		open
18	D2	LDOSEL	I	Regulator output voltage select.		GND
19	E2	MICOUT	O	MIC signal Output.		open
20	G3	HDP1	I/O	MHL/USB/UART D+ Signal path1		open
21	G2	HDM1	I/O	MHL/USB/UART D- Signal path1		open
22	F3	HDP2	I/O	MHL/USB/UART D+ Signal path2		open
23	F2	HDM2	I/O	MHL/USB/UART D- Signal path2		open
24	G5	EARR	I	Headphone Right signal path	500Ω *1	open
25	G4	EARL	I	Headphone Left signal path	500Ω *1	open
26	E1	HDPR	I/O	MHL/USB/UART/Earphone/MIC Signal Path		open
27	F1	HDML	I/O	MHL/USB/UART/Earphone Signal Path		open
28	D3	CHG_DET	O	USB Charging port detection		open
29	G6	ID	I/O	ID pull down resistance connecting pin		open
30	E5	SCL	I	I2C Clock signal input		GND
31	E6	SDA	I/O	I2C Data signal input		GND
32	D6	INTB	O	Interrupt signal output		open
33	E4	RST	I	Reset signal input		GND
34	D4	USBDISEN	I	USB Port detection disable.		GND
35	G7	TMODE0	I	TEST Pin(for Vendor TEST)	1MΩ	open or GND
36	G1	TMODE1	I	TEST Pin(for Vendor TEST)	1MΩ	open or GND
37	A1	ATEST0	I/O	TEST Pin(for Vendor TEST)		Open
38	A7	ATEST1	I/O	TEST Pin(for Vendor TEST)		Open
39	D5	DCDMODE	I	DCD Time out select.		GND
40	C6	IDSEL	I	I2C Device address select		GND
41	C3	INDEX	-	Index mark		open

*1 Turn on and turn off can be controlled by Register.

3. Block Diagram

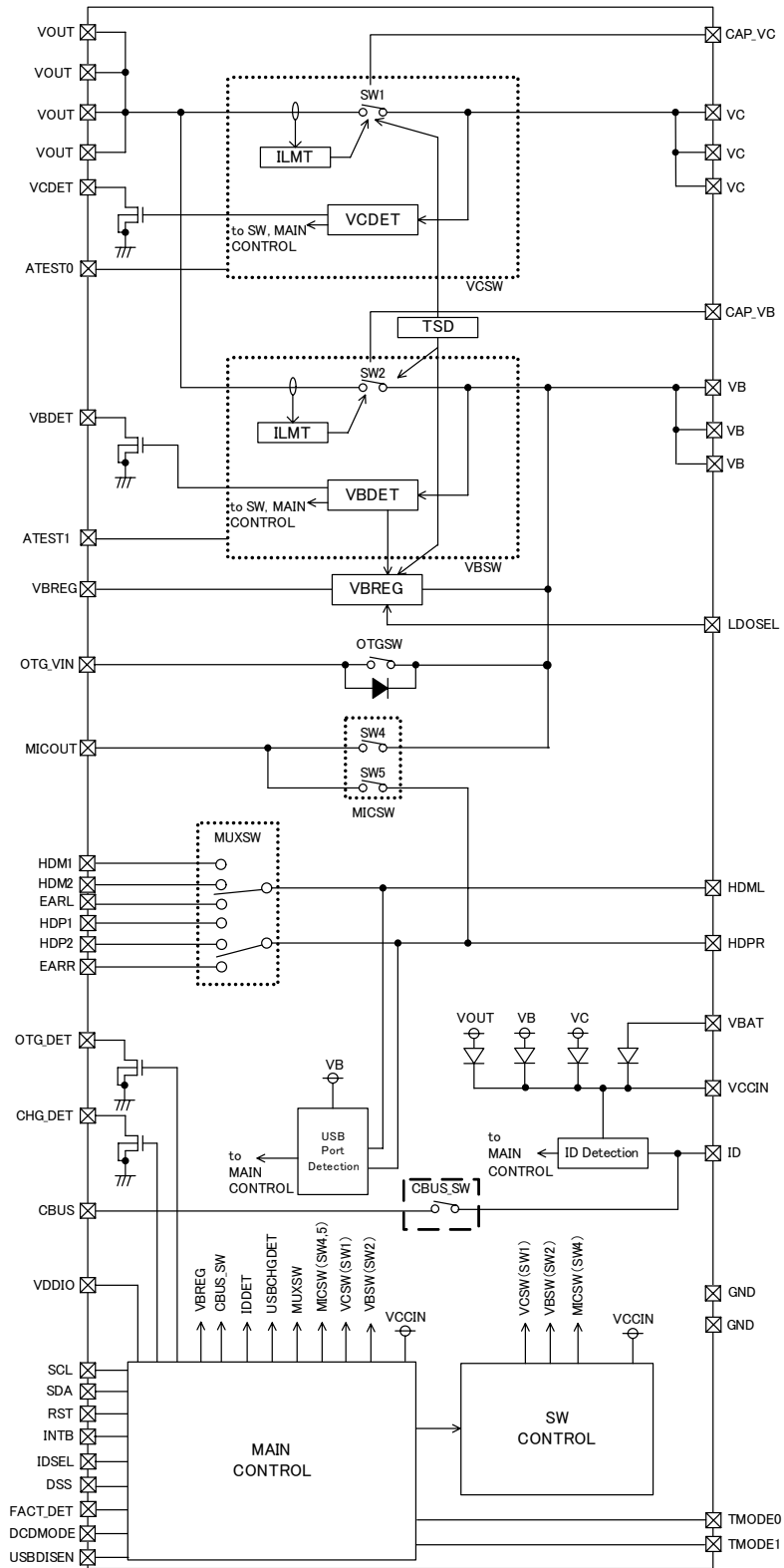

Fig.3 Block Diagram

4. Absolute Maximum Ratings (Ta=25°C)

Item	Symbol	Rating	Unit
Maximum Supply Voltage1 (VB, VC)	VIN1	-0.3~30	V
Maximum Supply Voltage2 (VBAT)	VIN2	-0.3~6.0	V
Maximum Supply Voltage3 (VDDIO)	VIN3	-0.3~4.5	V
Maximum Supply Voltage4 (HDP1, HDM1,)	VIN4	-1.0~7.0	V
Maximum Supply Voltage5 (HDP2, HDM2)	VIN5	-1.0~7.0	V
Maximum Supply Voltage6 (EAPR, EARL)	VIN6	-1.5~7.0	V
Maximum Supply Voltage7 (HDPR, HDML,)	VIN7	-1.5~7.0	V
Maximum Supply Voltage8 (VOUT, CAP_VB, CAP_VC, OTG_VIN)	VIN8	-0.3~7.0	V
Maximum Supply Voltage9 (Others pins)	VIN9	-0.3~6.0	V
Power Dissipation	Pd	1346 (*1)	mW
Operating Temperature Range	Topr	-30 ~ +85	°C
Storage Temperature Range	Tstg	-55 ~ +125	°C

*1 This value is the permissible loss using a ROHM specification board (50mm x 58mm board mounting).

At the time of PCB mounting the permissible loss varies with the size and material of board.

When using more than at Ta=25°C, it is reduced 10.77 mW per 1°C. (Caution)

Use in excess of this value may result in damage to the device. Moreover, normal operation is not protected.

5. Recommended Operating Ratings (Ta=25°C)

Item	Symbol	Range	Unit
VB, VC Voltage	VB	3.8 ~ 28	V
VBAT Voltage	VBAT	2.9 ~ 4.6	V
VDDIO Voltage	VDDIO	1.7 ~ 3.0	V
OTG_VIN Voltage	VOTG	4.40 ~ 5.25	V

6. Electrical Characteristic (Unless otherwise specified, Ta=25°C, VBAT=3.6V, VB=5.0V, VC=5.0V, VDDIO=1.8V, OTG_VIN=0V)

Parameter	Symbol	Min.	Typ.	Max.	Unit	Condition
● Circuit Current						
VBAT Circuit Current 1 (Standby)	IQVBAT1	-	6	20	μA	VBAT=3.6V, VDDIO=1.8V VB=VC=Open, OTG_VIN=0V ID=Open
VDDIO Circuit current 1 (Standby)	IQVDDIO1	-	0.0	1.0	μA	
VBAT Circuit Current 2 (HDSW =ON))	IQVBAT2	-	3	10	μA	VBAT=3.6V, VDDIO=1.8V VB=5V, VC=Open, OTG_VIN=0V ID=Open HDSW=ON
VB Circuit Current 2 (HDSW =ON)	IQVB2	-	210	450	μA	
VBAT Circuit Current 3 (HPSW,MICSW= ON)	IQVBAT3	-	55	150	μA	VBAT=3.6V, VDDIO=1.8V, VB=VC=Open, OTG_VIN=0V ID=287kΩ pull down HPSW,MICSW=ON
VC Circuit Current 4 (standby)	IQVC4	-	150	300	μA	VC=5.0V, VB=0.0V, OTG_VIN=0V,
VBAT Circuit Current 5 (OTGSW =ON)	IQVBAT5	-	3	10	μA	VBAT=3.6V, VDDIO=1.8V, VB=VC=Open OTG_VIN=5V ID=0kΩ pull down OTGSW=ON
OTG_VIN Circuit Current 5 (OTGSW =ON)	IQOTG5	-	230	450	μA	

● Electrical Characteristic (Unless otherwise specified, Ta=25°C, VBAT=3.6V, VB=VC=5.0V, VDDIO=1.8V, OTG_VIN=0V)

Parameter	Symbol	Min.	Typ.	Max.	Unit	Condition
● Digital characteristics(Digital Pins: SCL, SDA, RST, INTB, CHG_DET, OTG_DET, FACT_DET, VCDET and VBDET, IDSEL, LDOSEL, USBDISEN, DCDMODE, DSS)						
Input "H" level (SCL, SDA, RST)	VIH1	$0.8 \times VDDIO$	-	$VDDIO+0.3$	V	
Input "L" level (SCL, SDA, RST)	VIL1	-0.3	-	$0.2 \times VDDIO$	V	
Input leak current (SCL, SDA, RST)	IIC1	-1	0	1	μA	Pin voltage: VDDIO
Output Voltage "L" (SDA)	VOLSDA	-	-	0.4	V	IOL=6mA
Output Voltage "L" (INTB, VCDET, VBDET, CHG_DET, OTG_DET, FACT_DET)	VOL1	-	-	0.3	V	Source=1mA
OFF Leakage Current (INTB, CHG_DET, OTG_DET, FACT_DET)	IIOFF1	-3	-	3	μA	VIN=VDDIO
OFF Leakage Current (VCDET, VBDET)	IIOFF2	-3	-	3	μA	VIN=VC(VCDET) or VB(VBDET)
Input "H" Level (IDSEL, USBDISEN,DCDMODE, DSS)	VIH2	$0.8 \times VCCIN$	-	$VCCIN+0.3$	V	*1
Input "L" Level (IDSEL, USBDISEN,DCDMODE, DSS)	VIL2	-0.3	-	$0.2 \times VCCIN$	V	*1
Input "H" Level (LDOSEL)	VIH3	2.0	-	$VCCIN+0.3$	V	*1
Input "L" Level (LDOSEL)	VIL3	-0.3	-	0.6	V	
Input Leakage Current(IDSEL, LDOSEL, USBDISEN, DCDMODE, DSS)	IIC2	-1	0	1	μA	Pin voltage: VCCIN
Diode forward Voltage	Vf	-	0.6	-	V	

*1 VCCIN = (VOUT or VBAT or VB or VC) - Vf

●Electrical Characteristic (Unless otherwise specified, Ta=25°C, VBAT=3.6V, VB=5.0V, VC=0.0V, VDDIO=1.8V, OTG_VIN=0V)

Parameter	Symbol	Min.	Typ.	Max.	Unit	Condition
●OVP (VB : SW2)						
UVLO release voltage	UVLO1H	3.6	3.8	4.0	V	VIN=up
UVLO detect voltage	UVLO1L	3.0	3.125	3.25	V	VIN=down
OVLO detect voltage	OVLO1	6.2	6.4	6.6	V	VIN=up
OVLO hysteresis voltage	OVLOh1	-	120	-	mV	VIN=down
Over current limit	ILM1	2.0	-	-	A	
On resistance of SW	RON1	-	120	250	mΩ	VB - VOUT SW
Start up delay time	Ton1	-	5	10	msec	
Output turn off time	Toff1	-	1	5	μ sec	
Reverse Leak Current	Ileak1	-3	-	3	μ A	VB=0.0V, VC=5.0V

●Electrical Characteristic (Unless otherwise specified, Ta=25°C, VBAT=3.6V, VB=0.0V, VC=5.0V, VDDIO=1.8V, OTG_VIN=0V)

Parameter	Symbol	Min.	Typ.	Max.	Unit	Condition
●OVP (VC : SW1)						
UVLO release voltage	UVLO2H	3.6	3.8	4.0	V	VIN=up
UVLO detect voltage	UVLO2L	3.0	3.125	3.25	V	VIN=down
OVLO detect voltage	OVLO2	6.2	6.4	6.6	V	VIN=up
OVLO hysteresis voltage	OVLOh2	-	120	-	mV	VIN=down
Over current limit	ILM2	2.0	-	-	A	
On resistance of SW	RON2	-	120	250	mΩ	VC - VOUT SW
Start up delay time	Ton2	-	5	10	msec	
Output turn off time	Toff2	-	1	5	μ sec	
Reverse Leak Current	Ileak2	-3	-	3	μ A	VB=5.0V, VC=0.0V

●Electrical Characteristic (Unless otherwise specified, Ta=25°C, VBAT=3.6V, VB=5.0V, VC=0.0V, VDDIO=1.8V, OTG_VIN=0V)

Parameter	Symbol	Min.	Typ.	Max.	Unit	Condition
●VBREG						
Output Voltage (3.3V Mode)	LDOVOUT 33	3.20	3.30	3.40	V	LDOSEL=H, Iload = 1mA
Output Voltage (4.9V Mode)	LDOVOUT 49	4.75	4.90	5.05	V	LDOSEL=L, Iload = 1mA
Output Current	LDOMAXI	30	-	-	mA	

●Electrical Characteristic (Unless otherwise specified, Ta=25°C, VBAT=3.6V, VB=VC=0V, VDDIO=1.8V, OTG_VIN=5V)

Parameter	Symbol	Min.	Typ.	Max.	Unit	Condition
●OTGSW						
On resistance of SW	RON OTGSW	-	0.2	0.5	Ω	OTG_VIN=5.0V OTGSW=ON
Output turn off time	Toff3	-	0.2	5	μ sec	

●Electrical Characteristic (Unless otherwise specified, Ta=25°C, VBAT=3.6V, VDDIO=1.8V, VB=VC=0V, OTG_VIN=0V)

Parameter	Symbol	Min.	Typ.	Max.	Unit	Condition
●HPSW (EARR,EARL)						
Analog signal input range	VIN_LR	-1.4	—	1.4	V	
ON resistance	RON HPSW	—	5	10	Ω	EARR = EARL= 0V SINK=10mA
Total Harmonic Distortion	THD_HP	—	0.02	0.10	%	f=1kHz Vin=1.4Vpp RL=16Ω Filter:20kHz LPF
Cross talk	CT	—	—	-90	dB	RL=16Ω, f=1kHz Filter: DIN AUDIO
Pull down resistance	RPD HPSW	—	500	—	Ω	
HPSW start up time	TUPHP	-	-	2	ms	HPSW OFF->ON

●Electrical Characteristic (Unless otherwise specified, Ta=25°C, VBAT=3.6V, VB=5.0V, VDDIO=1.8V, VC=0V, OTG_VIN=0V)

Parameter	Symbol	Min.	Typ.	Max.	Unit	Condition
●HDSW (HDP1, HDM1, HDP2, HDM2)						
SW resistance when ON	RON HDSW	—	5	10	Ω	VIN=3.3V or 0V
Input current when OFF	IIOFF	-3	—	3	μA	VIN=3.3V or 0V VB=OPEN
SW capacitance	CSW	—	(6)	—	pF	HDSW ON
HDSW start up time	TUPHD	—	—	2	ms	HDSW OFF->ON

●Electrical Characteristic (Unless otherwise specified, Ta=25°C, VBAT=3.6V, VDDIO=1.8V, VB=VC=0V, OTG_VIN=0V)

Parameter	Symbol	Min.	Typ.	Max.	Unit	Condition
●MICSW (MIC : SW4, SW5)						
Analog signal input range	VIN_MIC	0	—	2.5	V	
SW resistance when ON	RON MICSW	—	20	40	Ω	VIN=2.5V or 0V
Input current when OFF	IIOFF	-3	—	3	μA	VIN=2.5V or 0V
Total Harmonic Distortion	THD_MIC	—	0.02	0.10	%	f=1kHz Vin=1.0Vpp Vbias=2.0V RL=10kΩ Filter:20kHz LPF
MICSW start up time	TUPMIC	-	-	2	ms	MICSW OFF-> ON

●Electrical Characteristic (Unless otherwise specified, Ta=25°C, VBAT=3.6V, VDDIO=1.8V, VB=VC=0V, OTG_VIN=0V)

Parameter	Symbol	Min.	Typ.	Max.	Unit	Condition
●CBUSSW						
On resistance of SW	RON CBUSSW	—	5	10	Ω	VIN=3.3V or 0V
Cut off Frequency	FCCBUS	-	(100)	-	MHz	@-3dB
Leak current when OFF	IIOFF	-3	—	3	μA	VIN=3.3V or 0V
CBUSSW start up time	TUPCBUS	-	-	2	ms	CBUSSW OFF->ON

●Electrical Characteristic (Unless otherwise specified, Ta=25°C, VBAT=3.6V, VB=5.0V, VDDIO=1.8V, VC=0V, OTG_VIN=0V)

Parameter	Symbol	Min.	Typ.	Max.	Unit	Condition
●USBCHG_DET						
VDP_SRC Voltage (D+ Output Voltage)	VDP_SRC	0.5	0.6	0.7	V	Io=0~200uA
VDM_SRC Voltage (D- Output Voltage)	VDM_SRC	0.5	0.6	0.7	V	Io=0~200uA
RCD Resistance (D+ pull up resistance)	RCD	75	100	125	kΩ	
Not USB port detect (Host D+ pull down resistance)	RHDP	100	-	-	kΩ	
VDAT_REF voltage (D+/D- detect voltage)	VDAT_REF	0.3	0.35	0.4	V	When HDPR/HDML up
VLGC voltage (D+/D- detect voltage)	VLGC	1.2	1.4	1.6	V	When HDPR/HDML up
D+ sink current	IDP_SINK	50	85	150	uA	V(HDPR) = 0.6V
D- sink current	IDM_SINK	50	85	150	uA	V(HDML) = 0.6V

●Electrical Characteristic (Unless otherwise specified, Ta=25°C, VBAT=3.6V, VB=5.0V, VDDIO=1.8V)

Parameter	Symbol	Min.	Typ.	Max.	Unit	Condition
●ID						
Connected resistance detect	RIDopen	1000	-	-	kΩ	Open detection
	RID1	-	797	-	kΩ	
	RID2	-	557	-	kΩ	
	RID3	-	440	-	kΩ	
	RID4	-	390	-	kΩ	
	RID5	-	287	-	kΩ	
	RID6	-	200	-	kΩ	
	RID7	-	180	-	kΩ	
	RID8	-	124	-	kΩ	
	RID9	-	102	-	kΩ	
	RID10	-	68	-	kΩ	
	RID11	-	47	-	kΩ	
	RID12	-	36.5	-	kΩ	
	RID13	-	1	-	kΩ	
RID14	-	0	50	Ω	GND detection	
COMPH detection voltage	RatioH	85	90	95	%	Ratio = 100 x V (ID) / VCCIN [%] When ID voltage is up.
COMPL detection voltage	RatioL	22	26	30	%	Ratio = 100 x V (ID) / VCCIN [%] When ID voltage is down

7.Features

7-1.Pull down resistance detection in ID pin.

After power-on reset is released by applying a operating voltage to the VB, VC or VBAT pin, the IDRDET block is turned on and becomes ready for insertion detection by the 1.2-M Ω pull-up resistance. Insertion will be detected by connecting the pull-down resistance to the ID pin. Insertion will be detected also when an operating voltage is applied to the VB, VC or VBAT pin with the pull-down resistance connected to the ID pin

When AD conversion will be completed, the interrupt will be triggered.

7-1-1.Priority of MHLSW and ID detection.

When the signal path connecting the ID pin and the CBUS pin is turned on, all functions for detecting the resistance value of the ID pin are disabled.

7-1-2.Application with SEND/END switch detection.

When the detected value of the resistance connected to the ID pin is 797 k Ω , 557 k Ω , 287 k Ω , or 47 k Ω , the comparator COMPL for judging presses on the SEND/END switch will be turned on. By pressing the SEND/END switch of the application, "1" will be written to the register, and at the same time, an interrupt will be triggered at the INTB pin.

7-1-2-1.OTG Application Detection

When the detected value of the resistance connected to the ID pin is below 20 Ω , the OTG_DET pin will be driven to L assuming that a OTG device is detected and "1" will be written to Register.

7-1-2-2.MHL Application Detection

When the detected value of the resistance connected to the ID pin is 1K Ω , a MHL application is detected.

7-1-3.Enable for ID pin pull down resistance detection.

The function of detecting the value of the resistance connected to the ID pin is turned on in the initial state but can be turned on or off by changing the setting in the register.

7-1-4.Retry of ID detection sequence.

During the period from the detection of the value of the ID pin pull-down resistance to detection of removed application, a retry can be made to AD-convert the value of the ID pin pull-down resistance at any desired timing by changing the setting in the register.

7-1-5.Polling mode of ID detection sequence.

The LSI will enter polling mode, in which the resistance value of the ID pin will be repeatedly detected, an interrupt will trigger to the INTB pin only when both ID resistance or register will be updated.

7-1-6.Remove ID pin pull down resistance. (Application detachment)

Pull-out detection will occur if the pull-down resistance is disconnected from the ID pin with the comparator COMPH turned on. After detection of removed application, and an interrupt will be triggered at the INTB pin.

7-2.USB port detection.

When the voltage is normally applied to the VB pin and power-on reset is released, the USB port detection function will be turned on and automatically detect the circuit connected to the HDPR pin and to the HDML pin. The USB port detection function can identify a Standard Downstream Port (SDP), a Dedicated Charging Port (DCP), and a Charging Downstream Port (CDP) that are compliant with BCS Rev. 1.2. Ports, except for some dedicated chargers, are designed to be SDP detected according to BCS Rev. 1.2 in principle if they are incompliant with USB standards or BCS. When USB port detection will be completed, the interrupt will be triggered.

7-2-1.Data Contact Detect/DCD

In data contact detection, contact detection to USB data pin (D+) is performed via HDPR pin. USB data pin contact is completed or timed out, and then this LSI performs Primary detection.

7-2-2.Configuration of DCD time out.

The timeout period can be selected by the DCDMODE external pin.

7-2-3.Primary Detection

In the primary detection, the HDML pin will be compared to identify whether the type of the connection destination host port is a BCS-compliant Charging port or the port defined in USB 2.0.

7-2-4. Secondary Detection

In the secondary detection, to identify whether the type of the connection destination host port is a Dedicated Charging Port compliant with BCS1.2 (BCS-compliant dedicated charger) or a Charging Downstream Port (BCS-complaint charging port through which data can be communicated).

Whichever type of charging port is detected, the result will be stored in the register, and the CHG_DET pin will be driven to inform that a Charging port has been connected.

7-2-5.Shortening of second detection by Enumeration preparation

The second detection after primary is detected has already been shortened while judging the USB port when a portable device equipped with this LSI is possible Enumeration and CDP will be detected compulsorily.

7-2-6.Sequence Retrying.

After the completion of the USB port detection (SDPDET, CDPDET, or DCPDET in the state transition diagram), detection can be retried at any timing. Retries will not be accepted while USB port detection is operating.

7-2-7.Deactivation of USB port detection by External PIN and Internal Register.

The combination of the USBDISEN external pin and the USBDETCTRL@02h register makes it possible to freely turn on or off the USB port detection function.

7-3.Signal paths

This LSI is capable of controlling the signal paths between the HDPR/HDML pins and the HDP1/HDM1, HDP2/HDM2,EARR/EARL, and MICOUT pins from the I2C interface. It is capable of controlling the signal path between the VB pin and the MICOUT pin as well.

For MHL transmission/USB transmission, use the path to HDP1/HDM1 or to HDP2/HDM2 enabling high-speed transmission. The signal paths to EARR/EARL and to MICOUT do not support high-speed signal transmission.

7-3-1.HDPR/HDML Signal paths

The HDPR pin has a signal path to each of the HDP1, HDP2, EARR, and MICOUT pins, whereas the HDML pin has a signal path to each of the HDM1, HDM2, and EARL pins.

7-3-2.Configuration of MUXSW initial path by DSS PIN.

The initially selected state of the signal paths can be controlled by the DSS pin. When the state of the DSS pin is "L," the signal path to the HDP1/HDM1 pin will be selected. When the state of the DSS pin is "H," the signal path to the HDP2/HDM2 pin will be selected.

7-3-3.Pull-down resistance in EARR/RARL pin.

A 500Ω pull-down resistance exists in the signal paths to the EARL pin and the EARR pin. The ON/OFF state of these resistances can be controlled independently by the register.

7-3-4.Signal path between ID pin and CBUS pin.

The ID pin has a signal path to the CBUS pin. The signal paths can be selected in the register.

7-4.Interrupt report with INTB pin.

This LSI reports such events as the completion of detection of the resistor connected to the ID pin and the completion of USB port detection to trigger as interrupt signals to the INTB pin. The INTB pin is of an Nch open drain structure, and the logic of an interrupt to be triggered is determined by the register. In the initial state, the INTB pin is set to be driven to L when an interrupt is triggered. The output of the pin is Hi-Z when there is no interrupt.

7-4-1.Active level selector of INTB.

The active level for interrupts can be selected in the register. In the initial state, the value in the register is "0," which drives the INTB pin to "L" at the time of the trigger of an interrupt. By writing "1" into the register, the INTB pin will open (Hi-Z) at the time of the trigger of an interrupt.

7-4-2.Interrupt polarity.

Interrupt polarity can be changed by writing register. In initial state INTB is droved with "L" when interrupt will be triggered.

7-5.Detection of Cradle and VBUS by VBDET pin and VCDET pin.

The application of a voltage from the VBUS or cradle can be detected using the VBDET pin or VCDET pin.

7-6.Detection of Cradle and VBUS by I2C interface reading.

The application of the voltage to the VBUS pin or cradle can be checked through the I2C interface by controlling of registers.

7-7.Detection of Over current state by I2C Interface reading.

This LSI has an independent OCP in each of the VB and VC power supply systems, and its over-current state can be detected by accessing it from the I2C interface.

7-8.Thermal Shut down.

If the junction temperature exceeds the set temperature, the thermal shutdown circuit will become activated and turn off the SW1 and SW2 of the OVP. The TSD detection temperature is 180°C, and the hysteresis temperature for recovery is 10°C.

7-9.VBREG Regulator.

This LSI has a regulator driven by the VBUS voltage. The output from the regulator can be turned on by the VBREG pin in the default state by increasing the voltage of the VB pin to UVLO or a higher level. The VBREG output pin is available for external applications, and two output voltage levels can be selected by LDOSEL pin.

7-10.OTG mode control

To permit power supply from a portable device in the On-The-Go mode of USB2.0, this LSI has an independent power path from the OTG_VIN pin to the VB pin.

7-11.VBUS signal path.

This LSI can select the signal path from the VB pin to the MICOUT pin. By setting "1" in the register with UVLO applied to the VB pin, the VB pin and the MICOUT pin will be connected to each other. These pins will be disconnected by setting "0" in the register.

7-12.Reset systems

This LSI has three reset modes - "power-on reset," "hardware reset," and "software reset." Any resets initialize all functions include all registers.

7-12-1.Power-On Reset

Power-on reset initializes all of the functions of this LSI. When VCCIN is supplied, power-on reset will be automatically released as the UVLO of the VB, VC, or VBAT pin is cleared.

7-12-2.Hardware Reset with RST.

A hardware reset is triggered by external pin RST and can reset all of the functions of this LSI. RST is an H enable pin. It triggers a reset when a voltage within the VIH voltage range is applied to the RST pin, and releases the reset when a voltage within the VIL voltage range is applied to the RST pin.

7-12-3.Software reset from I2C Interface writing.

A software reset can be executed by writing "1" into register from the I2C interface. A software reset can initialize all of the functions of this LSI.

7-13.I²C Interface electrical characteristics.

AC Characteristics on I²C Bus.

Characteristics	Sign	Min	Max	Unit
CLK clock frequency	f _{CLK}	0	400	kHz
CLK clock "low" time	t _{LOW}	1.3	-	μs
CLK clock "high" time	t _{HIGH}	0.6	-	μs
Bus free time	t _{BUF}	1.3	-	μs
Start condition hold time	t _{HD.STA}	0.6	-	μs
Start condition setup time	t _{SU.STA}	0.6	-	μs
Data input hold time	t _{HD.DAT}	0	0.9	μs
Data input setup time	t _{SU.DAT}	100	-	ns
Stop condition setup time	t _{SU.STO}	0.6	-	μs

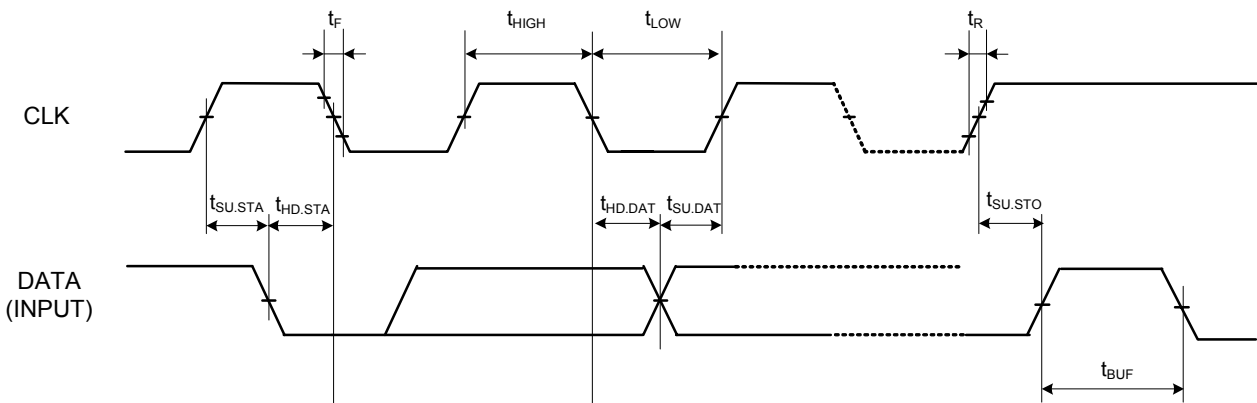

Fig 1. SCL/SDA bus AC Timing 1

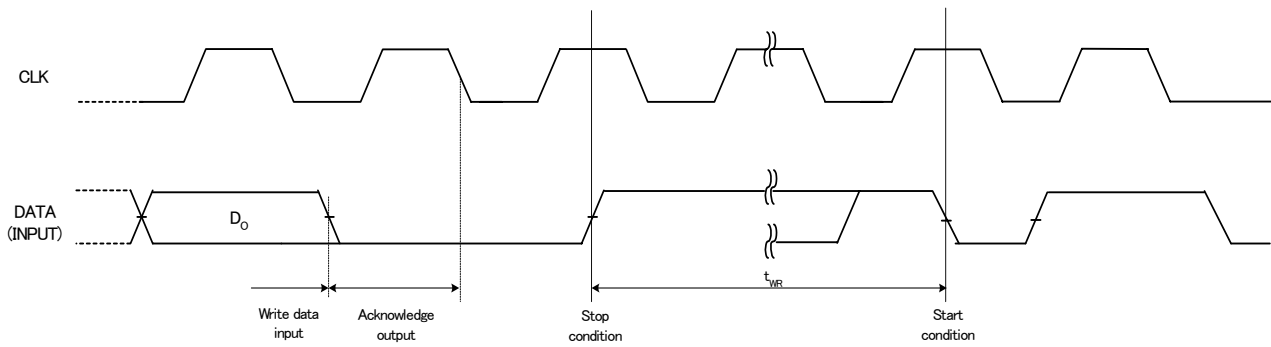

Fig 2. SCL/SDA bus AC Timing 2

7-14. I²C Bus Interface

7-14-1. START and STOP Conditions

When CLK is set at "H" and DATA is changed from "H" and "L," a start condition will be established, and access will begin. By setting changing SDA from "L" to "H" with CLK set at "H," a stop condition will be satisfied, and access will be terminated. All commands begin with a start condition and stop with a stop condition. If a stop condition is generated in the middle of reading, reading will be discontinued, and the application will enter standby mode.

If a stop condition is generated in the middle of writing, writing will be suspended until the next start condition, and the application will enter standby mode.

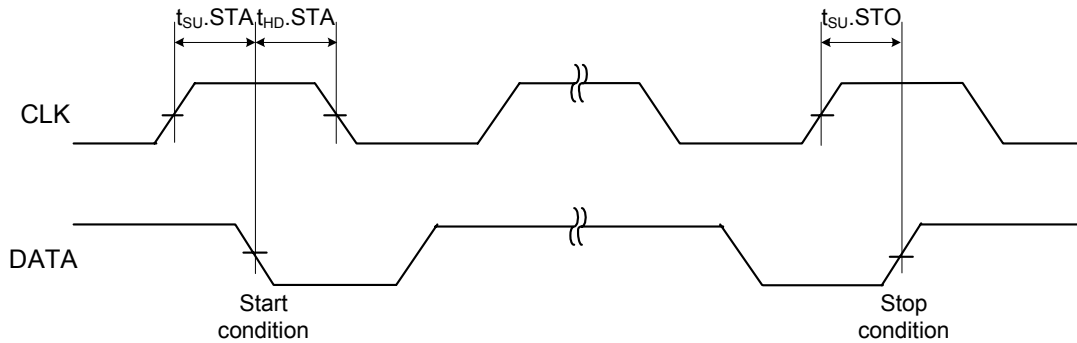

Fig. 3. START and STOP Condition AC Timing.

7-14-2. Modifying Data

One-bit data is transferred while SCL is "H". During bit data transfer, the signal transition of SDA cannot be executed while CL is "H". When SCL is "H" and SDA changes, a start condition or stop condition will be generated and interpreted as a control signal.

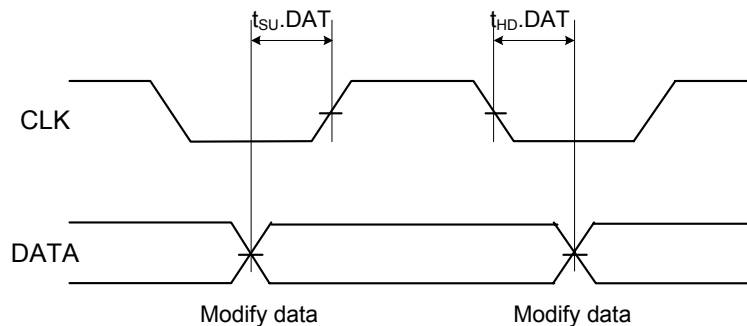

Fig 4. Data transfer AC Timing.

7-14-3.Acknowledge

After a start condition is generated, data will be transferred in eight-bit blocks. After data transfer in eight-bit blocks, the transmitter opens SDA in the ninth cycle, and the receiver returns an acknowledge signal in the ninth cycle by changing SDA to "L." The data is thereby received in a proper manner.

During writing, the receiver returns an acknowledge signal each time it receives eight-bit data, and the transmitter receives the signal.

During reading, the transmitter returns an acknowledge signal after it receives an address following a start condition. The transmitter then receives read data and opens the bus to wait for an acknowledge signal from the receiver. When an acknowledge signal is detected, the receiver outputs the next address data unless a stop condition is generated. Unless acknowledge signal is detected or stop condition is generated, the receiver does not enter standby mode. The bus is kept open until an acknowledge signal or stop condition is detected.

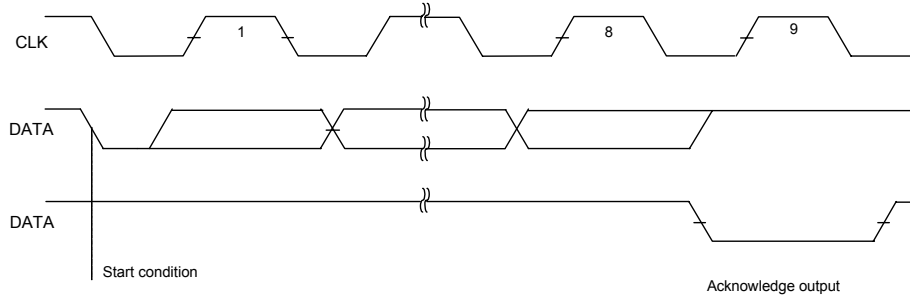
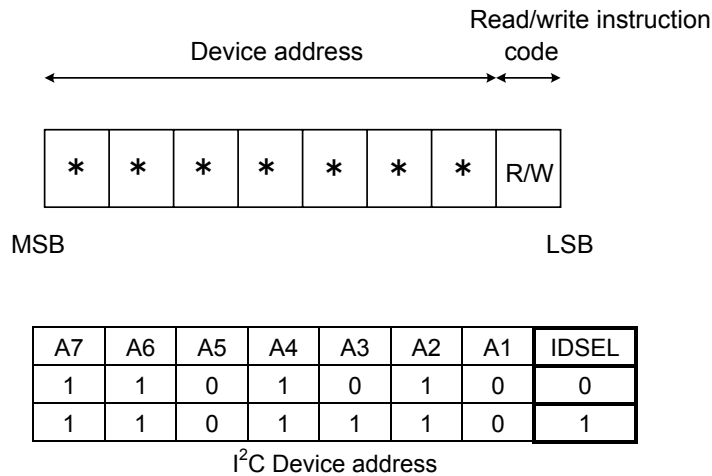

Fig 5. Acknowledge AC Timing.

7-14-4.Device Address

After a start condition is generated, a seven-bit device address and the a one-bit read/write command selection bit will be input. The device address is "1101110" when IDSEL is "H" (VCCIN short), or "1101010" when IDSEL is "L" (GND short). A one-bit (R/E READ/WRITE) signal becomes a read command when it is set at "1," or a write command when it is set at "0." If the device address does not match, the command will not be executed.



7-14-5. Write operation

To write data to the designated address, input the device address, the one-bit signal of "0" (R/W command selection bit), the word address, and the data to be written after the start condition.

The application enters standby mode upon generation of a stop condition.

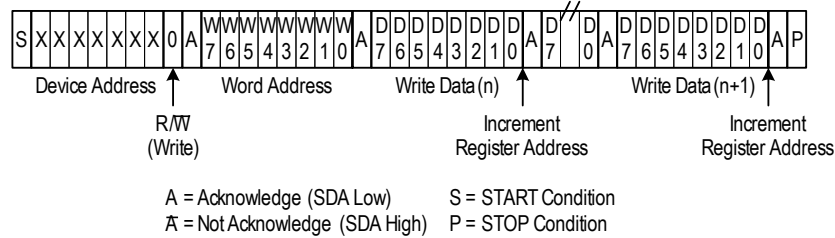

Fig 6. Write protocol sequence.

Write a start condition, a device address, a one-bit signal of "0" (R/W command selection bit), a word address (n), and address (n + 1) data. The acknowledge signal will become "0" or be checked unless a stop condition is generated.

7-14-6. Address roll back specification.

Write, read, and complex read will perform, and the word address will be rolled over by address 00h when the address reaches 07h.

7-14-7. Read back operation.

When reading data from the designated address, the data to be read will be output by writing a device address, a one-bit signal of "0" (R/W command selection bit), and a word address after a start condition and then inputting a start condition, a device address, and a one-bit signal of "1" (R/W command selection bit).

The bus opens with a stop condition.

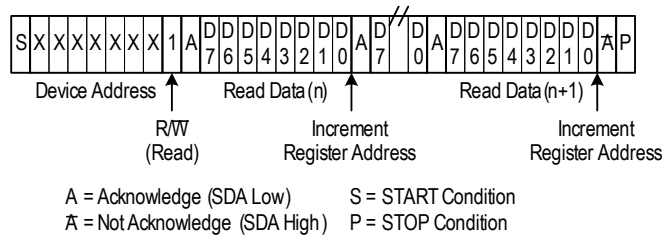

Fig 7 Read back protocol sequence.

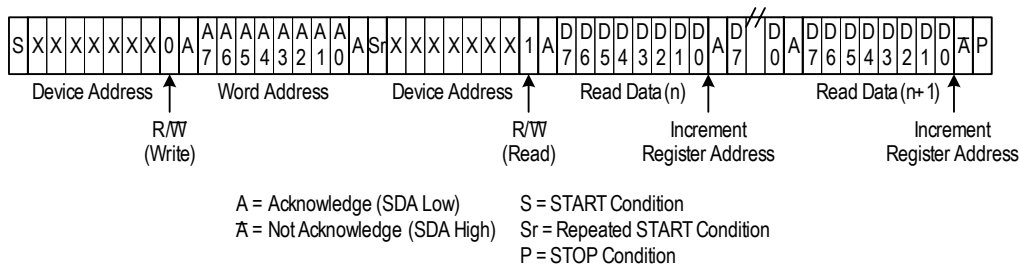

Fig 8. Complex read back protocol sequence.

Complex read back a start condition, a device address, a one-bit signal of "0" (R/W command selection bit), a word address (n), and address (n + 1) data. The acknowledge signal will become "0" or be checked unless a stop condition is generated.

8. Typical Performance Curves

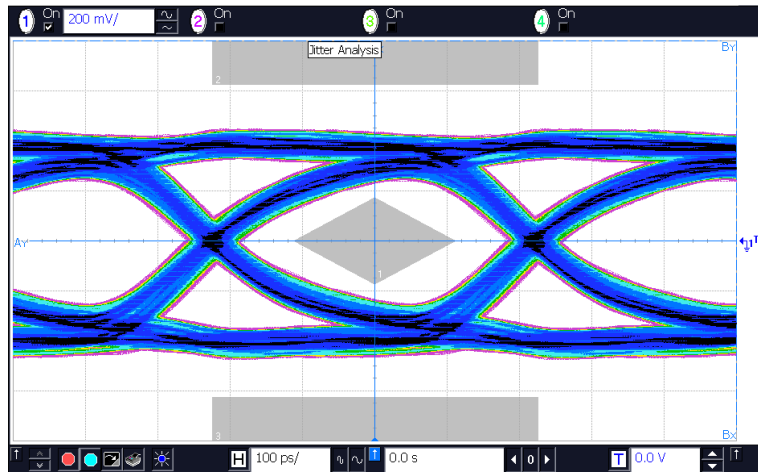

Fig12.MHL Eye-Pattern(720p, 60Hz)

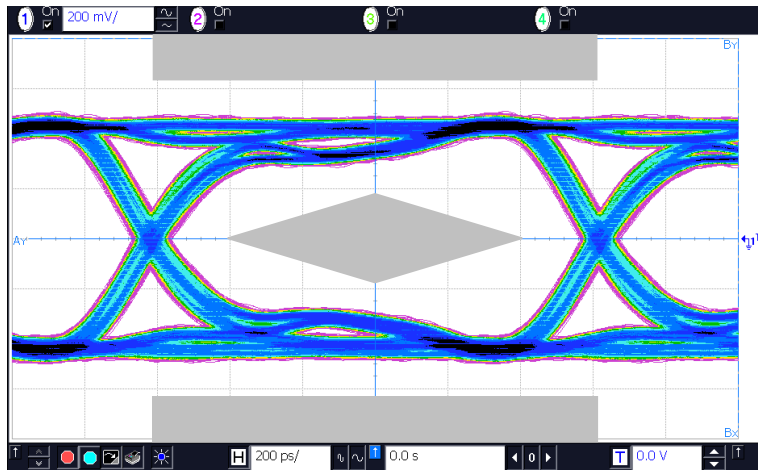

Fig13.MHL Eye-Pattern(480p, 60Hz)

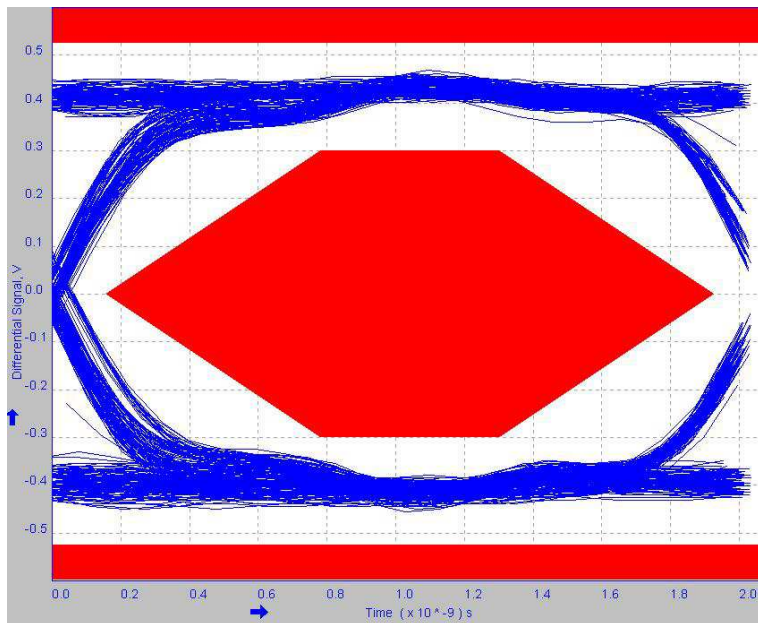

Fig14.USB Eye-Pattern(High-speed)

9.Application Circuit Diagram

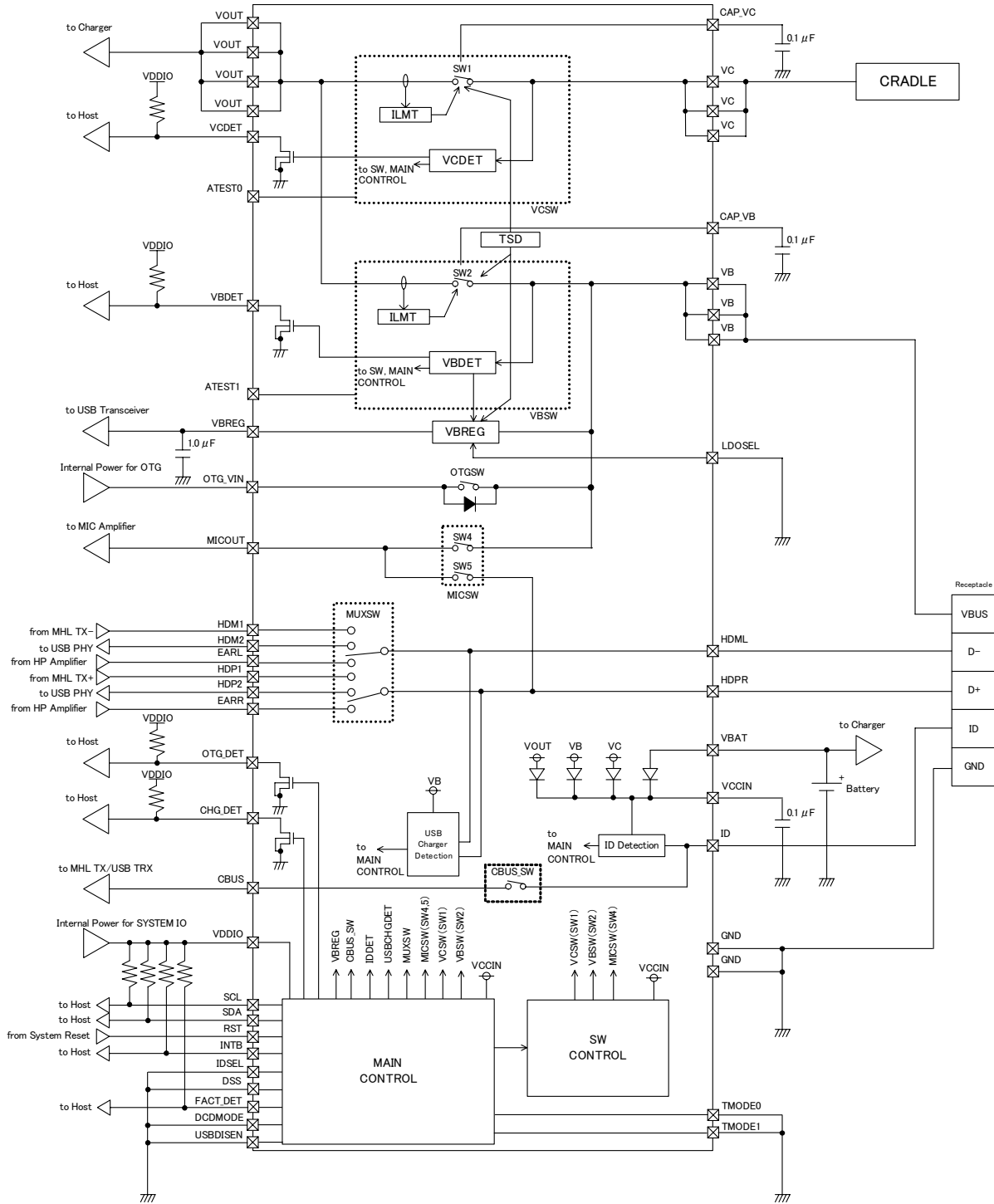
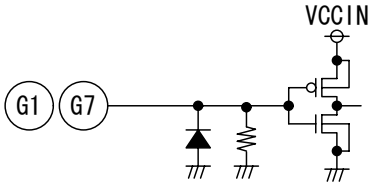
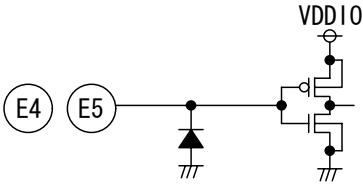
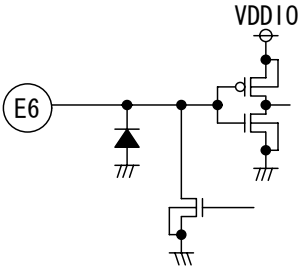
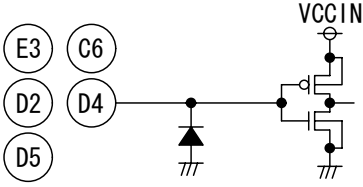
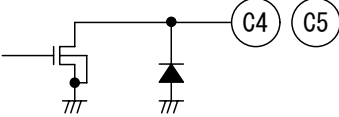

Fig.15 Application Circuit Diagram

10. I/O equivalence circuits

Ball No.	Ball Name	I/O equivalence circuits
G1 G7	TMODE0 TMODE1	
E4 E5	RST SCL	
E6	SDA	
E3 C6 D2 D4 D5	DSS IDSEL LDOSEL USB1SEN DCDMODE	
C4 C5	VCDET VBDET	

Ball No.	Ball Name	I/O equivalence circuits
<p>B6 B7 C7 A6 A4 A5 B4 B5 A2 A3 B2 B3 B1</p>	<p>VC VC VC CAP_VC VOUT VOUT VOUT VOUT VB VB VB CAP_VB OTG_VIN</p>	
<p>E2</p>	<p>MICOUT</p>	
<p>E1 F1</p>	<p>HDPR HDML</p>	

Ball No.	Ball Name	I/O equivalence circuits
F6	VCCIN	
C1	VBREG	
F5	CBUS	
A7 A1	ATEST1 ATEST0	
E7 F7	VBAT VDDIO	

Ball No.	Ball Name	I/O equivalence circuits
G2 G3	HDM1 HDP1	
G4 G5	EARL EARR	
F2 F3	HDM2 HDP2	
D6 F4 D3 C2	INTB FACT_DET CHG_DET OTG_DET	
G6	ID	

11. Operational Notes

- 1) Absolute maximum ratings
If applied voltage, operating temperature range (Topr), or other absolute maximum ratings are exceeded, there is a risk of damage. Since it is not possible to identify short, open, or other damage modes, if special modes in which absolute maximum ratings are exceeded are assumed, consider applying fuses or other physical safety measures.
- 2) Recommended operating range
This is the range within which it is possible to obtain roughly the expected characteristics. For electrical characteristics, it is those that are guaranteed under the conditions for each parameter. Even when these are within the recommended operating range, voltage and temperature characteristics are indicated.
- 3) Reverse connection of power supply connector.
There is a risk of damaging the LSI by reverse connection of the power supply connector. For protection from reverse connection, take measures such as externally placing a diode between the power supply and the power supply pin of the LSI.
- 4) Power supply lines
In the design of the board pattern, make power supply and GND line wiring low impedance. When doing so, although the digital power supply and analog power supply are the same potential, separate the digital power supply pattern and analog power supply pattern to deter digital noise from entering the analog power supply due to the common impedance of the wiring patterns. Similarly take pattern design into account for GND lines as well. Furthermore, for all power supply pins of the LSI, in conjunction with inserting capacitors between power supply and GND pins, when using electrolytic capacitors, determine constants upon adequately confirming that capacitance loss occurring at low temperatures is not a problem for various characteristics of the capacitors used.
- 5) GND voltage
About the pins except for EARR, EARL, DPRXR and DMTXL, make the potential of a GND pin such that it will be the lowest potential even if operating below that. In addition, confirm that there are no pins for which the potential becomes less than a GND by actually including transition phenomena.
- 6) Shorts between pins and miss assemble
When assemble in the set board, pay adequate attention to orientation and placement discrepancies of the LSI. If it is assembled erroneously, there is a risk of LSI damage. There also is a risk of damage if a foreign substance getting between pins or between a pin and a power supply or GND shorts it.
- 7) Operation in strong magnetic fields
Be careful when using the LSI in a strong magnetic field, since it may malfunction.
- 8) Inspection in set board
When inspecting the LSI in the set board, since there is a risk of stress to the LSI when capacitors are connected to low impedance LSI pins, be sure to discharge for each process. Moreover, when getting it on and off of a jig in the inspection process, always connect it after turning off the power supply, perform the inspection, and remove it after turning off the power supply. Furthermore, as countermeasures against static electricity, use grounding in the assembly process and take appropriate care in transport and storage.
- 9) Input pins
Parasitic elements inevitably are formed on a LSI structure due to potential relationships. Because parasitic elements operate, they give rise to interference with circuit operation and may be the cause of malfunctions as well as damage. Accordingly, take care not to apply a lower voltage than GND to an input pin or use the LSI in other ways such that parasitic elements operate. Moreover, do not apply a voltage to an input pin when the power supply voltage is not being applied to the LSI. Furthermore, when the power supply voltage is being applied, make each input pin a voltage less than the power supply voltage as well as within the guaranteed values of electrical characteristics.
- 10) Ground wiring pattern
When there is a small signal GND and a large current GND, it is recommended that you separate the large current GND pattern and small signal GND pattern and provide single point grounding at the reference point of the set so that voltage variation due to resistance components of the pattern wiring and large currents do not cause the small signal GND voltage to change. Take care that the GND wiring pattern of externally attached components also does not change.
- 11) Externally attached capacitors
When using ceramic capacitors for externally attached capacitors, determine constants upon taking into account a lowering of the rated capacitance due to DC bias and capacitance change due to factors such as temperature.
- 12) Thermal shutdown circuit (TSD)
When junction temperatures become 180°C (typ) or higher, the thermal shutdown circuit operates and turns OVP switch OFF. The thermal shutdown circuit, which is aimed at isolating the LSI from thermal runaway as much as possible, is not aimed at the protection or guarantee of the LSI. Therefore, do not continuously use the LSI with this circuit operating or use the LSI assuming its operation.
- 13) Thermal design
Perform thermal design in which there are adequate margins by taking into account the permissible dissipation (Pd) in actual states of use.

Status of this document

The Japanese version of this document is formal specification. A customer may use this translation version only for a reference to help reading the formal version.

If there are any differences in translation version of this document formal version takes priority

12. Ordering Information

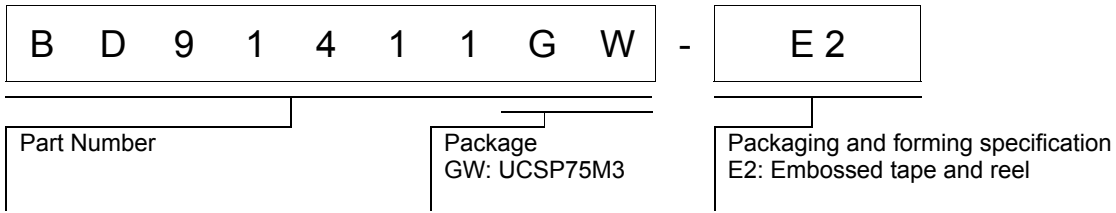

13. Physical Dimension Tape and Reel Information

UCSP75M3(BD91411GW)

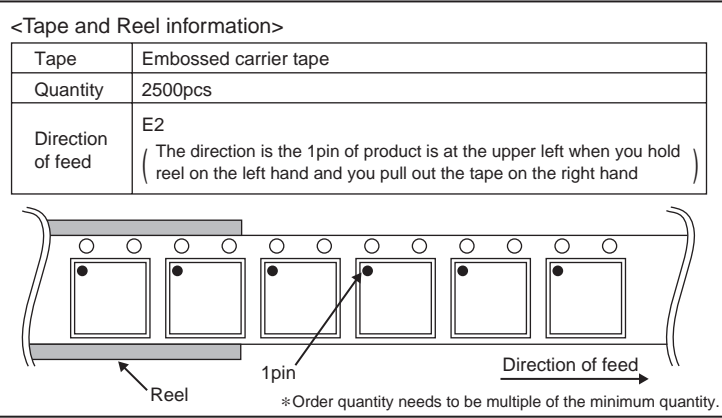
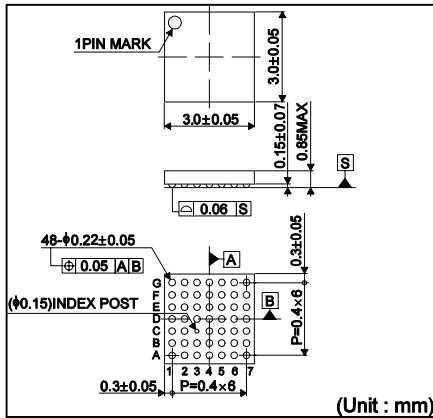

14. Marking Diagram

UCSP75M3(BD91411GW)
TOP VIEW

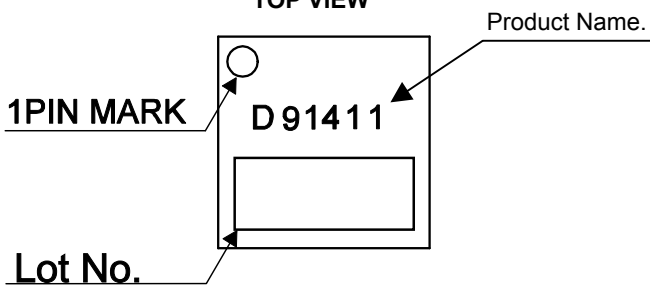

15.Revision History

Date	Revision	Changes
13.Jul.2012	001	New Release

Notice

●General Precaution

- 1) Before you use our Products, you are requested to carefully read this document and fully understand its contents. ROHM shall not be in any way responsible or liable for failure, malfunction or accident arising from the use of any ROHM's Products against warning, caution or note contained in this document.
- 2) All information contained in this document is current as of the issuing date and subject to change without any prior notice. Before purchasing or using ROHM's Products, please confirm the latest information with a ROHM sales representative.

●Precaution on using ROHM Products

- 1) Our Products are designed and manufactured for application in ordinary electronic equipments (such as AV equipment, OA equipment, telecommunication equipment, home electronic appliances, amusement equipment, etc.). If you intend to use our Products in devices requiring extremely high reliability (such as medical equipment, transport equipment, traffic equipment, aircraft/spacecraft, nuclear power controllers, fuel controllers, car equipment including car accessories, safety devices, etc.) and whose malfunction or failure may cause loss of human life, bodily injury or serious damage to property ("Specific Applications"), please consult with the ROHM sales representative in advance. Unless otherwise agreed in writing by ROHM in advance, ROHM shall not be in any way responsible or liable for any damages, expenses or losses incurred by you or third parties arising from the use of any ROHM's Products for Specific Applications.
- 2) ROHM designs and manufactures its Products subject to strict quality control system. However, semiconductor products can fail or malfunction at a certain rate. Please be sure to implement, at your own responsibilities, adequate safety measures including but not limited to fail-safe design against the physical injury, damage to any property, which a failure or malfunction of our Products may cause. The following are examples of safety measures:
 - [a] Installation of protection circuits or other protective devices to improve system safety
 - [b] Installation of redundant circuits to reduce the impact of single or multiple circuit failure
- 3) Our Products are designed and manufactured for use under standard conditions and not under any special or extraordinary environments or conditions, as exemplified below. Accordingly, ROHM shall not be in any way responsible or liable for any damages, expenses or losses arising from the use of any ROHM's Products under any special or extraordinary environments or conditions. If you intend to use our Products under any special or extraordinary environments or conditions (as exemplified below), your independent verification and confirmation of product performance, reliability, etc. prior to use, must be necessary:
 - [a] Use of our Products in any types of liquid, including water, oils, chemicals, and organic solvents
 - [b] Use of our Products outdoors or in places where the Products are exposed to direct sunlight or dust
 - [c] Use of our Products in places where the Products are exposed to sea wind or corrosive gases, including Cl₂, H₂S, NH₃, SO₂, and NO₂
 - [d] Use of our Products in places where the Products are exposed to static electricity or electromagnetic waves
 - [e] Use of our Products in proximity to heat-producing components, plastic cords, or other flammable items
 - [f] Sealing or coating our Products with resin or other coating materials
 - [g] Use of our Products without cleaning residue of flux (even if you use no-clean type fluxes, cleaning residue of flux is recommended); or Washing our Products by using water or water-soluble cleaning agents for cleaning residue after soldering
 - [h] Use of the Products in places subject to dew condensation
- 4) The Products are not subject to radiation-proof design.
- 5) Please verify and confirm characteristics of the final or mounted products in using the Products.
- 6) In particular, if a transient load (a large amount of load applied in a short period of time, such as pulse) is applied, confirmation of performance characteristics after on-board mounting is strongly recommended. Avoid applying power exceeding normal rated power; exceeding the power rating under steady-state loading condition may negatively affect product performance and reliability.
- 7) De-rate Power Dissipation (Pd) depending on Ambient temperature (Ta). When used in sealed area, confirm the actual ambient temperature.
- 8) Confirm that operation temperature is within the specified range described in the product specification.
- 9) ROHM shall not be in any way responsible or liable for failure induced under deviant condition from what is defined in this document.

● **Precaution for Mounting / Circuit board design**

- 1) When a highly active halogenous (chlorine, bromine, etc.) flux is used, the residue of flux may negatively affect product performance and reliability.
- 2) In principle, the reflow soldering method must be used; if flow soldering method is preferred, please consult with the ROHM representative in advance.

For details, please refer to ROHM Mounting specification

● **Precautions Regarding Application Examples and External Circuits**

- 1) If change is made to the constant of an external circuit, please allow a sufficient margin considering variations of the characteristics of the Products and external components, including transient characteristics, as well as static characteristics.
- 2) You agree that application notes, reference designs, and associated data and information contained in this document are presented only as guidance for Products use. Therefore, in case you use such information, you are solely responsible for it and you must exercise your own independent verification and judgment in the use of such information contained in this document. ROHM shall not be in any way responsible or liable for any damages, expenses or losses incurred by you or third parties arising from the use of such information.

● **Precaution for Electrostatic**

This Product is electrostatic sensitive product, which may be damaged due to electrostatic discharge. Please take proper caution in your manufacturing process and storage so that voltage exceeding the Products maximum rating will not be applied to Products. Please take special care under dry condition (e.g. Grounding of human body / equipment / solder iron, isolation from charged objects, setting of Ionizer, friction prevention and temperature / humidity control).

● **Precaution for Storage / Transportation**

- 1) Product performance and soldered connections may deteriorate if the Products are stored in the places where:
 - [a] the Products are exposed to sea winds or corrosive gases, including Cl₂, H₂S, NH₃, SO₂, and NO₂
 - [b] the temperature or humidity exceeds those recommended by ROHM
 - [c] the Products are exposed to direct sunshine or condensation
 - [d] the Products are exposed to high Electrostatic
- 2) Even under ROHM recommended storage condition, solderability of products out of recommended storage time period may be degraded. It is strongly recommended to confirm solderability before using Products of which storage time is exceeding the recommended storage time period.
- 3) Store / transport cartons in the correct direction, which is indicated on a carton with a symbol. Otherwise bent leads may occur due to excessive stress applied when dropping of a carton.
- 4) Use Products within the specified time after opening a humidity barrier bag. Baking is required before using Products of which storage time is exceeding the recommended storage time period.

● **Precaution for Product Label**

QR code printed on ROHM Products label is for ROHM's internal use only.

● **Precaution for Disposition**

When disposing Products please dispose them properly using an authorized industry waste company.

● **Precaution for Foreign Exchange and Foreign Trade act**

Since our Products might fall under controlled goods prescribed by the applicable foreign exchange and foreign trade act, please consult with ROHM representative in case of export.

● **Precaution Regarding Intellectual Property Rights**

- 1) All information and data including but not limited to application example contained in this document is for reference only. ROHM does not warrant that foregoing information or data will not infringe any intellectual property rights or any other rights of any third party regarding such information or data. ROHM shall not be in any way responsible or liable for infringement of any intellectual property rights or other damages arising from use of such information or data.:
- 2) No license, expressly or implied, is granted hereby under any intellectual property rights or other rights of ROHM or any third parties with respect to the information contained in this document.

●Other Precaution

- 1) The information contained in this document is provided on an "as is" basis and ROHM does not warrant that all information contained in this document is accurate and/or error-free. ROHM shall not be in any way responsible or liable for any damages, expenses or losses incurred by you or third parties resulting from inaccuracy or errors of or concerning such information.
- 2) This document may not be reprinted or reproduced, in whole or in part, without prior written consent of ROHM.
- 3) The Products may not be disassembled, converted, modified, reproduced or otherwise changed without prior written consent of ROHM.
- 4) In no event shall you use in any way whatsoever the Products and the related technical information contained in the Products or this document for any military purposes, including but not limited to, the development of mass-destruction weapons.
- 5) The proper names of companies or products described in this document are trademarks or registered trademarks of ROHM, its affiliated companies or third parties.