

**Standard EEPROMs**  
**Plug & Play EEPROMs**  
**(for Display)**



# BU9882xx-W Series (1K × 2BANK)

● **General Description**

BU9882F-W, BU9882FV-W are dual port EEPROMs compatible with the DDC2™. 2 independent ports allow 2 EDID channels to be read simultaneously.

● **Features**

- Designed for use with DDC2™
- 2-port simultaneous read function
- Operating voltage range: 2.5V-5.5V
- Page write function: 8bytes
- Low power consumption
  - Active (at 5V) : 1.5mA (typ)
  - Stand-by (at 5V) : 0.1µA (typ)
- Data security
  - Write protection with  $\overline{WP}$
  - Write protection at low power supply voltage
- Initial data=FFh
- Data retention: 10years
- Rewriting possible up to 100,000 times

● **Packages W(Typ.) x D(Typ.) x H(Max.)**

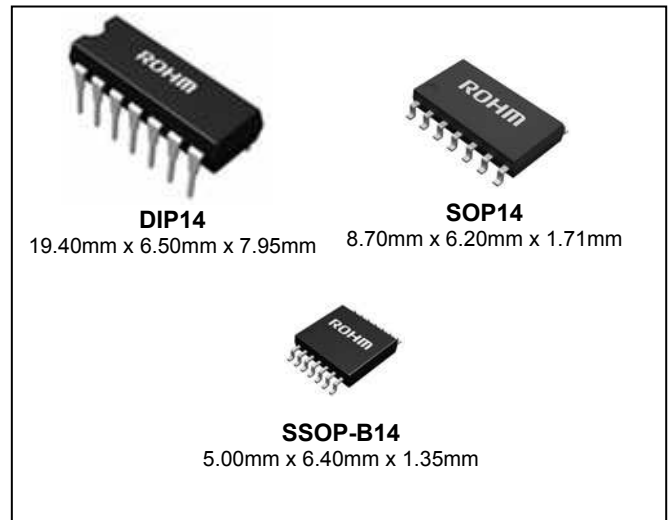

● **BU9882xx-W series**

Capacity	Type	Power source Voltage	DIP14	SOP14	SSOP-B14
2Kbit	BU9882	2.5V to 5.5V	●	●	●

● **Absolute Maximum Ratings**

Parameter	Symbol	Ratings	Unit	Remarks
Supply Voltage	V <sub>CC</sub>	-0.3 to +6.5	V	
Power Dissipation	Pd	950(DIP14)	mW	Reduce by 9.5 mW/°C over 25°C.
		450 (SOP14)		Reduce by 4.5 mW/°C over 25°C.
		350 (SSOP-B14)		Reduce by 3.5 mW/°C over 25°C
Storage Temperature	T <sub>stg</sub>	-65 to +125	°C	
Operating Temperature	T <sub>opr</sub>	-40 to +85	°C	
Terminal Voltage	-	-0.3 to V <sub>CC</sub> +1.0 *1	V	

\*1 6.8V (Max.)

● **Memory cell characteristics**

Parameter	Limits			Unit
	Min.	Typ.	Max	
Write/Erase Cycle	100,000	—	—	Times
Data Retention	10	—	—	Years

## ● Recommended Operating Ratings

Parameter	Symbol	Ratings	Unit
Supply Voltage	Vcc	2.5 to 5.5	V
Input voltage	VIN	0 to Vcc+1.0	

## ● Electrical characteristics

- DC (Unless otherwise specified, Ta=-40°C to +85°C, Vcc=2.5V to 5.5V)

Parameter	Symbol	Limits			Unit	Condition
		Min.	Typ.	Max.		
"H" Input Voltage 1	VIH1	2.0	-	-	V	
"L" Input Voltage 1	VIL1	-	-	0.8	V	Vcc ≥ 4.0V
"L" Input Voltage 2	VIL2	-	-	0.2Vcc	V	Vcc < 4.0V
"L" output Voltage	VOL1	-	-	0.4	V	SDA_PC0/1, IOL=3.0mA * 1
Input Leakage Current 1	ILI1	-1	-	1	μA	SCL_PC0/1, DDCENA, BANKSEL, VIN=0V to Vcc+1.0
Input Leakage Current 2	ILI2	-1	-	50	μA	WP
Output Leakage Current	ILO	-1	-	1	μA	SDA_PC0/1, SCL/SDA_MON(DDCENA=GND), VOUT=0V to Vcc+1.0
Operating Current	ICC	-	1.5	3.0	mA	fSCL=400kHz, Vcc=5.5V tWR=10ms
Standby Current	ISB	-	0.1	5	μA	SCL/SDA_PC0/1=Vcc SCL/SDA_MON=H-Z DDCENA=WP=BANKSEL=GND DUALPCB=Vcc

\*1 IOL at monitor mode (DDCENA=HIGH) is the sum of current flowing from the pull up resistor at the SDA\_MON side to the pull up resistance at SDA\_PC0/PC1

- AC (Unless otherwise specified, Ta=-40°C to +85°C, Vcc=2.5V to 5.5V)

Parameter	Symbol	Fast-mode Vcc=2.5V to 5.5V			Standard-mode Vcc=2.5V to 5.5V			Unit Typ.
		Min.	Typ.	Max.	Min.	Typ.	Max.	
Clock Frequency	fSCL	-	-	400	-	-	100	kHz
Data Clock High Period	tHIGH	0.6	-	-	4.0	-	-	μs
Data Clock Low Period	tLOW	1.3	-	-	4.7	-	-	μs
SDA and SCL Rise Time	tR	-	-	0.3	-	-	1.0	μs
SDA and SCL Fall Time	tF	-	-	0.3	-	-	0.3	μs
Start Condition Hold Time	tHD:STA	0.6	-	-	4.0	-	-	μs
Start Condition Setup Time	tSU:STA	0.6	-	-	4.7	-	-	μs
Input Data Hold Time	tHD:DAT	0	-	-	0	-	-	ns
Input Data Setup Time	tSU:DAT	100	-	-	250	-	-	ns
Output Data Delay Time(SCL)	tPD	-	-	0.9	-	-	3.5	μs
Stop Condition Setup Time	tSU:STO	0.6	-	-	4.0	-	-	μs
Bus Free Time	tBUF	1.3	-	-	4.7	-	-	μs
Write Cycle Time	tWR	-	-	10	-	-	10	ms
Noise Spike Width (SDA and SCL)	tl	-	-	0.1	-	-	0.1	μs

●Block Diagram

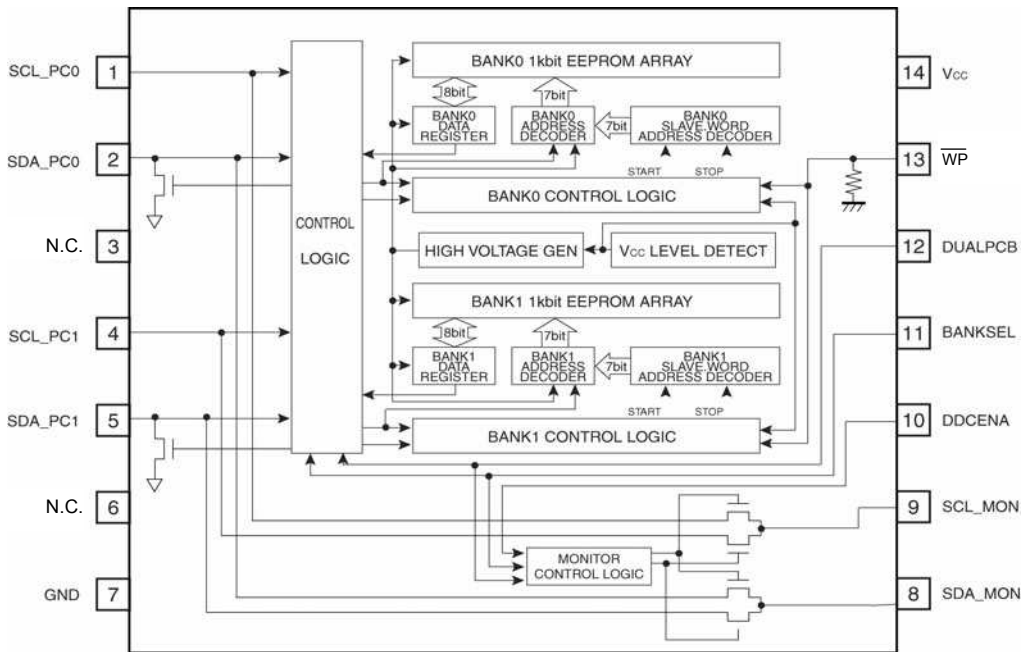

●Pin Configuration

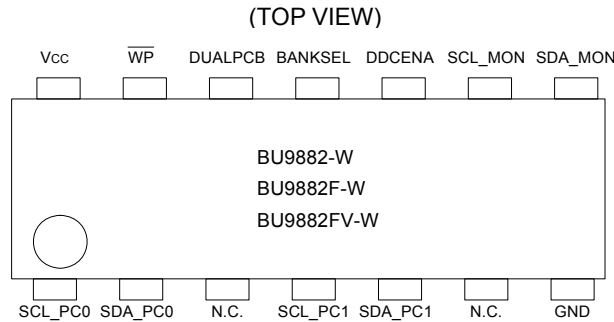

●Pin Descriptions

Pin Name	I/O	Functions
Vcc	-	Power Supply
GND	-	Ground (0V)
N.C.	-	No Connection
SCL_PC0	IN	Serial Clock Input, Access to BANK0 at DUAL PORT mode Access to BANK0 or to BANK1 at SINGLE PORT mode
SDA_PC0	IN/OUT	Slave and Word Address Serial Data Input, Serial Data Output Access to BANK0 at DUAL PORT mode, Access to BANK0 or to BANK1 at SINGLE PORT mode
SCL_PC1	IN	Serial Clock Input Access to BANK1 at DUAL PORT mode, Don't Care at SINGLE PORT mode
SDA_PC1	IN/OUT	Slave and Word Address Serial Data Input, Serial Data Output Access to BANK1 at DUAL PORT mode, Don't Care at SINGLE PORT mode
SCL_MON	OUT	Serial Clock Output Connected to SCL_PC0/1 at DDCENA="High", "Hi-Z" output at DDCENA="Low"
SDA_MON	OUT	Slave and Word Address Serial Data Output Connected to SCL_PC0/1 DDCENA="High", "Hi-Z" output at DDCENA="Low"
DDCENA	IN	Control of SCL_MON, SDA_MON
BANKSEL	IN	Select a SCL/SDA_MON Connected Port at DUAL PORT mode Selected a BANK at SINGLE PORT mode
DUALPCB	IN	Control of DUAL PORT/SINGLE PORT mode
WP	IN	Write Protect Control

An open drain output requires a pull-up resistor.

●Synchronous data timing

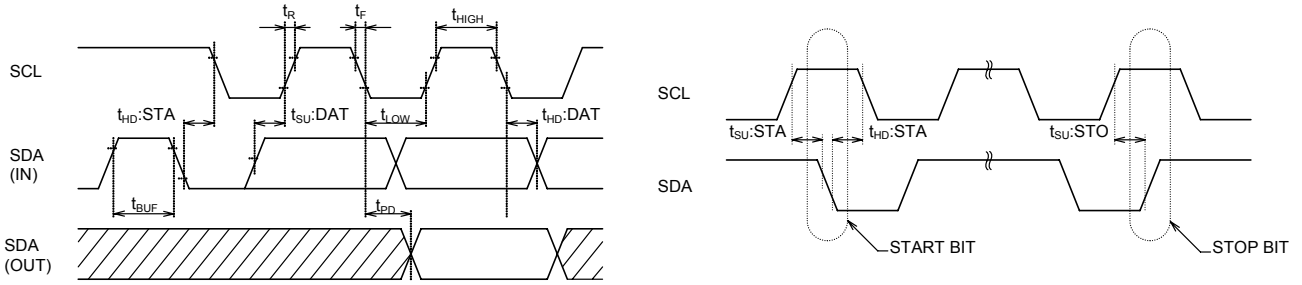

Figure 1. Synchronous Data Timing

- SDA data is latched into the chip at the rising edge of the SCL clock.
- The output date toggles at the falling edge of the SCL clock.

●Write cycle timing

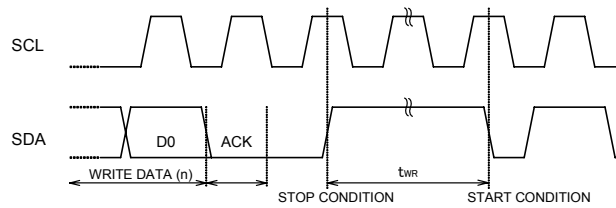

Figure 2. Write Cycle Timing

●Operation notes

ODDCENA Operation

When DDCENA is set to High, SCL\_PC0/1 and SDA\_PC0/1 will be connected to SCL\_MON and SDA\_MON, respectively. Therefore, monitoring of the communications between the PC and EEPROM, and the communications of the MONITOR and PC, is possible.

Selection of PC0/PC1 is determined according to the state of the DUALPCB and BANKSEL inputs.

When DDCENA is Low, the SCL/SDA\_MON output is set to "Hi-Z".

DUALPCB	BANKSEL	SCL_MON,SDA_MON (CONNECTION PORT)
Low (DUAL PORT)	Low	PC0 PORT
	High	PC1 PORT
High (SINGLE PORT)	Low	PC0 PORT
	High	

OBANKSEL

BANKSEL serves as an input for connection port of SCL/SDA\_MON during DUAL PORT mode.

It turns into the BANK selection terminal of internal memory in SINGLE PORT mode.

Only the PC0 port can access the memory in SINGLE PORT mode.

DUALPCB	BANKSEL	CONNECTION BANK
Low (DUAL PORT)	Low	PC0 PORT : BANK0
	High	PC1 PORT : BANK1
High (SINGL PORT)	Low	BANK0
	High	BANK1

OWP

When  $\overline{WP}$ =Low, all data at all addresses are write-protected. The terminal has a built-in pull down resistor. Make sure that  $\overline{WP}$ =High when writing data.

Utilize this function in order to prevent incorrect write command input from the PC, as well as incorrect input during communication between the PC and monitor.

○Data Read

The data read function allows simultaneous read from SCL\_PC0/1, SDA\_PC0/1 in DUAL PORT mode.

○Data Write

Write operation is performed using either PC0/1 (SCL or SDA) even when accessed simultaneously in DUAL PORT mode. Port selection is made by detecting the data D0 of the first byte of the WRITE command input.

After this, the other port is made unavailable for both READ and WRITE commands until the write operation is completed.

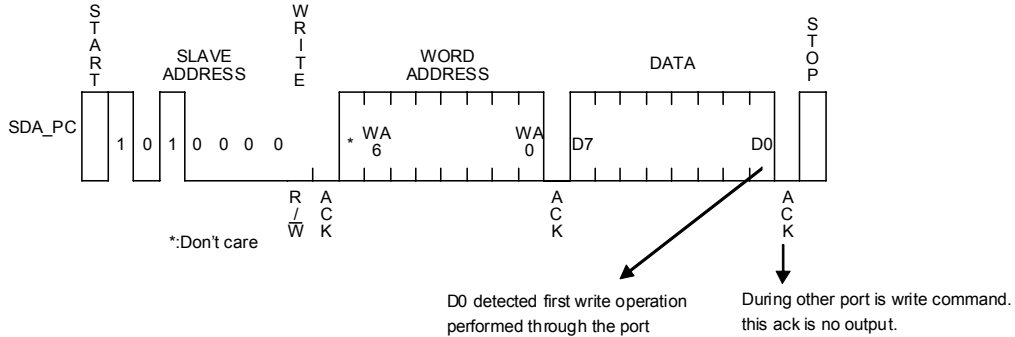

Figure 3. Write Cycle Timing

○START Condition

All commands are preceded by the START condition, which is a High to Low transition of SDA when SCL is High. This IC continuously monitors the SDA and SCL lines for the START condition and will not respond to any commands until this condition has been met.

○STOP Condition

All commands must be terminated by a STOP condition, which is a Low to High transition of SDA when SCL is HIGH. (See Figure 1.)

○WRITE Command

Unless a STOP condition is executed, the data will not be written into the memory array.

○DEVICE ADDRESSING

Following a START condition, the Master outputs the device address of the slave to be accessed.

The most significant four bits of the Slave address are the "device type identifier".

For the IC this is fixed as "1010".

The next three bits are "000".

The last bit of the stream determines the operation to be performed.

When set to "1", Read operation is selected ; when set to "0", Write operation is selected.

R/W set to "0" . . . . . WRITE

R/W set to "1" . . . . . READ

1010	0	0	0	R/W
------	---	---	---	-----

● Commands

○ Byte Write

When the Master generates a STOP condition, the IC begins an internal write cycle to the nonvolatile array.

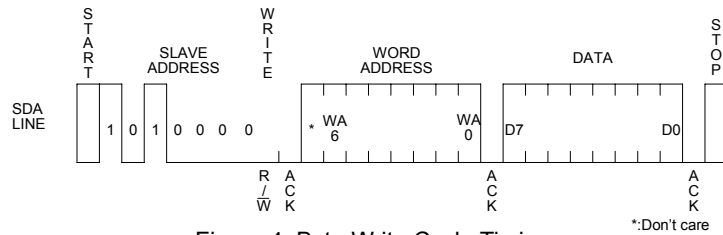

Figure 4. Byte Write Cycle Timing

○ Page Write

After the receipt of each word, the three low order address bits are internally increased by one. The four higher order bits of the address(WA6 to WA3) remain constant. This IC is capable of eight byte page write operation.

If the master transmits more than eight words, prior to generating the STOP condition, the address counter will "roll over", and the previous transmitted data will be overwritten.

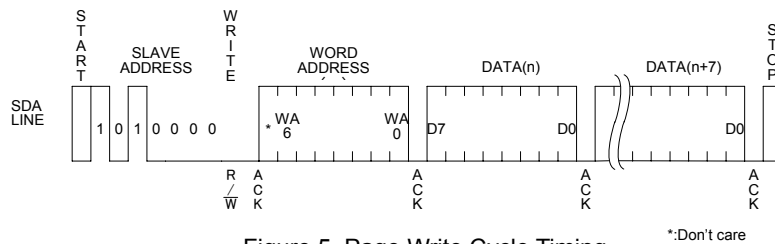

Figure 5. Page Write Cycle Timing

○ Current Read

In case the previous operation is random or current read (which includes sequential read), the internal address counter is increased by one from the last accessed address (n). Thus current read outputs the data of the next word address (n+1). If the last command is byte or page write, the internal address stays at the last address(n). Thus current read outputs the data of the word address (n).

If the master does not transfer the Acknowledge, but does generate a stop condition, the current address read operation only provides a single byte of data.

At this point, the BU9882/F/FV-W discontinues transmission.

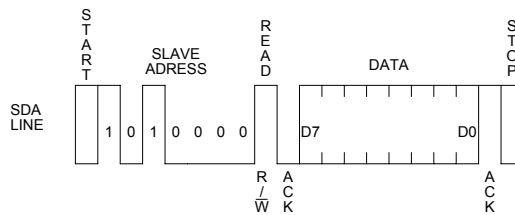

Figure 6. Current Read Cycle Timing

○ Random Read

Random read operation allows the master to access any location. If the master does not transfer the Acknowledge but does generate a stop condition, the current address read operation only provides a single byte of data. (At 1Kbit all address read possible). This communication must be terminated by a stop condition, which is a Low to High transition of SDA when SCL is High

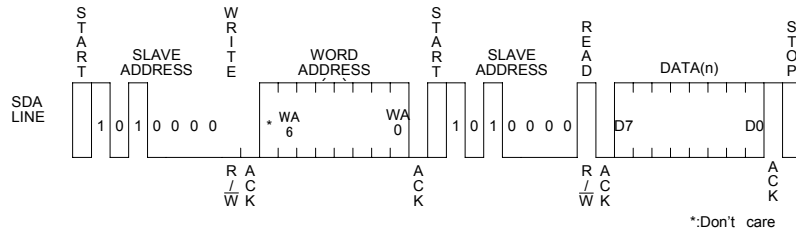

Figure 7. Random Read Cycle Timing

○ Sequential Read

During the Current read operation, if an Acknowledge is detected, and no STOP condition is generated by the master (μ-COM), the device will continue to transmit the data. (It can transmit all data(1Kbit 128word)). If an Acknowledge is not detected, the device will terminate further data transmissions and await a STOP condition before returning to the standby mode. The Sequential Read operation can be performed with both Current Read and Random Read.

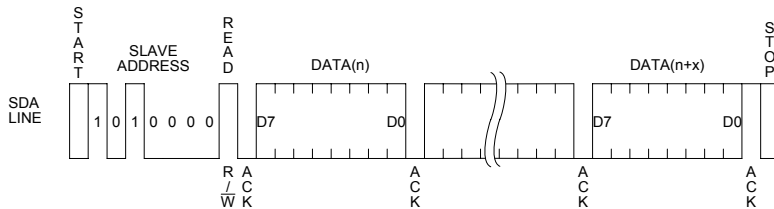

Figure 8. Sequential Read Cycle Timing

● Peripheral Circuits

○ DUAL PORT

DUAL PORTs are used to connect two PCs to one monitor. PC0 is connected to BANK0 and PC1 to BANK1. Each bank operates as 1Kbit EEPROM.

○ To Use DUAL PORT

Start the operation of the DUAL PORT by following the instructions below:

1. Set the DUAL PCB to LOW with neither of the ports being operated by commands.
2. Input the command from PC0 or PC1.

○ Simultaneous Access

<READ OPERATION>

EEPROM data read allows simultaneous access from PC0, PC1 ports.

<WRITE OPERATION>

Write operation is performed for either of PC0/1 even when accessed simultaneously from both.

Port selection is made by detecting the data D0 of the first byte of the WRITE command input.

Write operation is performed only for the port where D0 of the first byte of the write data is detected first.

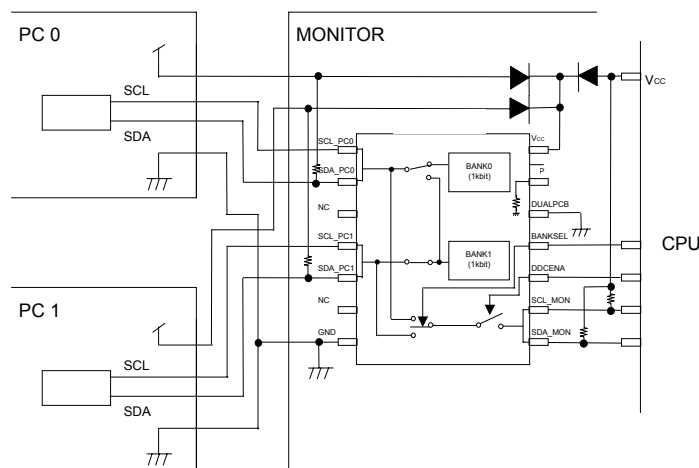

Figure 9. Example of Peripheral Circuit with Dual Port

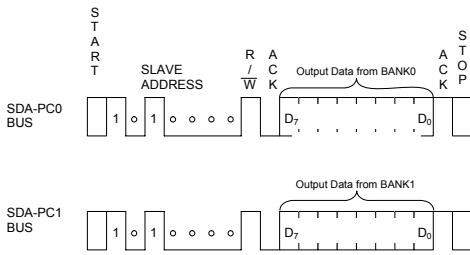

Figure 10. Simultaneous Access of Read Operation

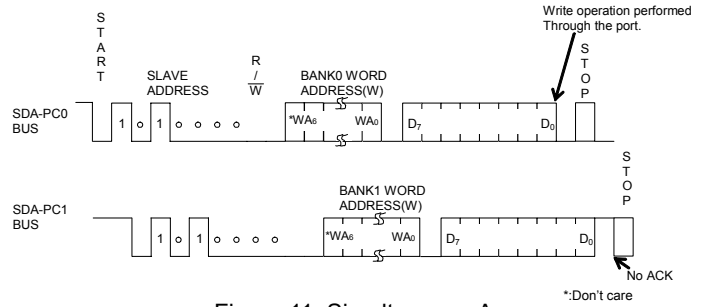

Figure 11. Simultaneous Access of White Operation

OMONITOR OUTPUT

BU9882F-W, BU9882FV-W has a monitor output terminal. This allows communication between the PC and monitor CPU. The monitor output for the use of DUAL PORT can be switched with BANKSEL input, as shown in the table below.

BANKSEL input	SCL_MON,SDA_MON connection port
Low	PC0 PORT
High	PC1 PORT

OSINGLE PORT

SINGLE PORT is for connecting one PC to one monitor. In this case, it is accessible only from PC0. BANK selection is made with BANKSEL.

Switching this BANKSEL allows access to the total of 2kbit EEPROM, with BANK0 and BANK1, from PC0.

○ To use SINGLE PORT

Start the SINGLE PORT operation by following the instructions below:

1. Set the DUAL PCB to High with neither of the ports being operated by commands.
2. Select the BANK with BANKSEL.
3. Input the command from PC0.

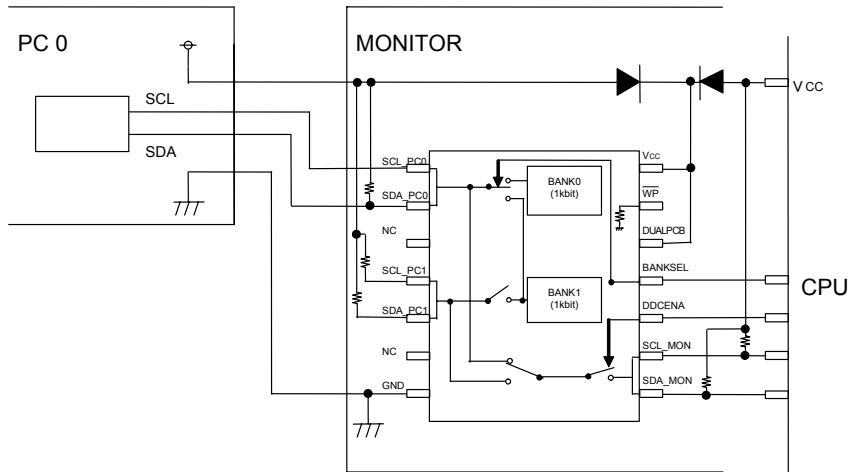

Figure 12. Example of Peripheral Circuit with Single Port

●Software Reset

Execute software reset in case the device is at an unexpected state after power up and/or the command input needs to be reset. The following figures (Figure 13-(a), Figure 13-(b), Figure 13-(c))  
 During dummy clock, please release SDA BUS (tied to Vcc by pull up resistor).  
 During that time, the device may pull the SDA line Low for acknowledge or outputting read data. If the master controls the SDA line High, it will conflict with the device output Low then it makes a current overload. It may cause instantaneous power down and may damage the device.

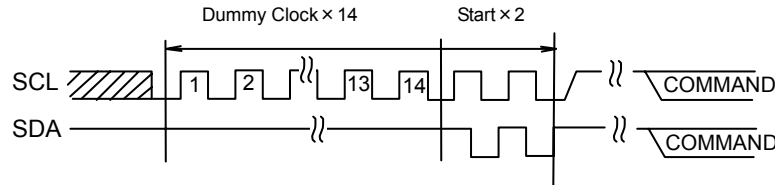

Figure 13-(a) Dummy Clock × 14 + Start + Start

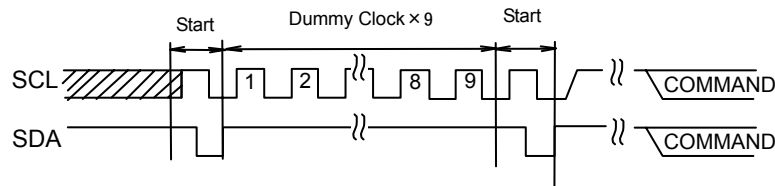

Figure 13-(b) Start + Dummy Clock × 9 + Start

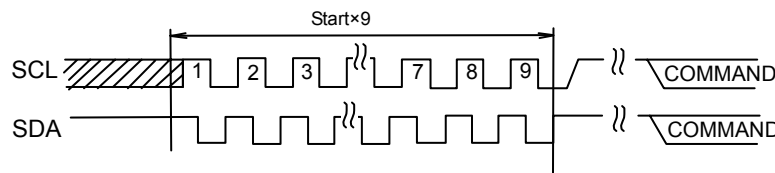

Figure 13-(c) Start × 9

●Acknowledge Polling

Since the device ignores all input commands during the internal write cycle, no ACK will be returned. When the master sends the next command following the write command, and the device returns the ACK, it means that the program is completed. If no ACK is returned, it means that the device is still busy. By using Acknowledge polling, the waiting time is minimized to less than  $t_{WR}=5ms$ . To prevent operating Write or Current Read immediately after Write, first send the slave address (R/W is "High" or "Low"). After the device returns the ACK, continue word address input or data output, respectively.

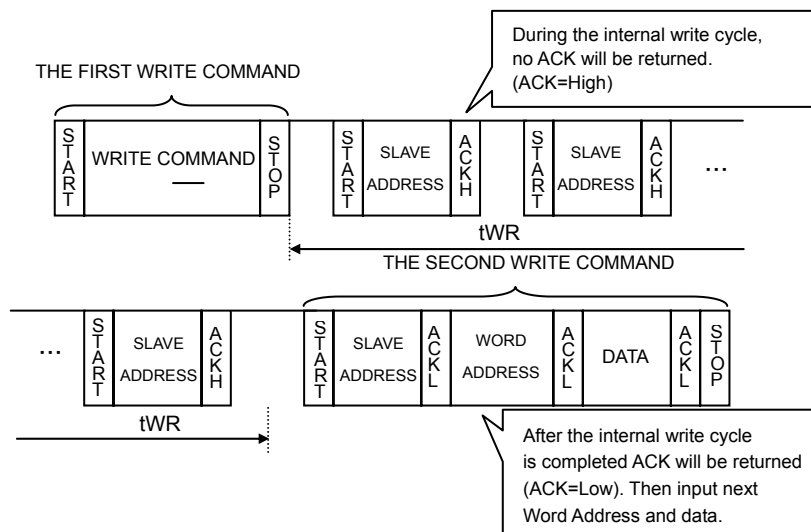

Figure 14. Successive Write Operation By Acknowledge Polling

●Command Cancellation By Start And Stop Condition

During a command input, command is canceled by the successive inputs of start condition and stop condition (Figure 15.). However, during ACK or data output, the device may output the SDA line Low. In such cases, operation of start and stop condition is impossible, making the reset inoperable. Execute the software reset in the cases. (Figure 13.) Operating the command cancels by starts and stop condition during the command of Random Read or Sequential Read or Current Read, internal address counter is not confirmed. Therefore operation of Current Read after this is not valid. Operate a Random Read in this case.

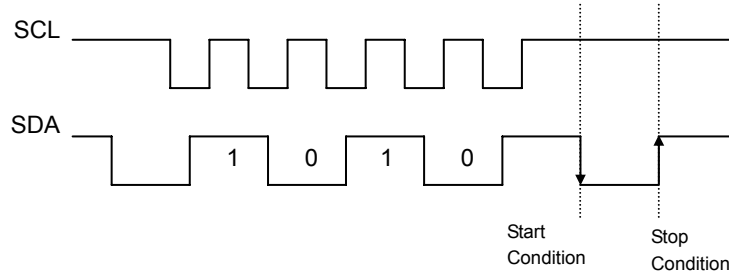

Figure 15. Command Cancellation

●I/O Circuit

○SDA Pin Pull-up Resistor

The pull up resistor is needed because SDA is NMOS open drain. Choose the correct value of this resistor(RPU), by considering VIL, IL characteristics of a controller which control the device and VOH, IOL characteristics of the device. If large RPU is chosen, clock frequency needs to be slow. In case of small RPU, the operating current increases.

○Maximum Rpu

Maximum value of RPU is determined by following factors:

- ①SDA rise time determined by RPU and the capacitance of bus line(CBUS) must be less than tR.
- 1) Other timing must keep the conditions of AC spec.
- ②When SDA bus is High, the voltage  $V_A$  of SDA bus determined by a total input leak(IL) of the all devices connected to the bus. RPU must be significantly higher than the High level input of a controller and the device, including a noise margin 0.2Vcc.

$$V_{CC} - I_L R_{PU} - 0.2 V_{CC} \geq V_{IH}$$

$$\therefore R_{PU} \leq \frac{0.8 V_{CC} - V_{IH}}{I_L}$$

Examples: When  $V_{CC}=3V$   $I_L=10\mu A$   $V_{IH}=0.7V_{CC}$   
According to ②

$$R_{PU} \leq \frac{0.8 \times 3 - 0.7 \times 3}{10 \times 10^{-6}}$$

$$\leq 300 [k\Omega]$$

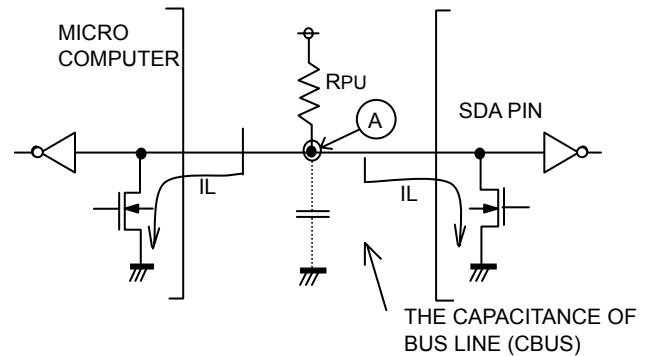

Figure 16. I/O Circuits

○Minimum RPU

The minimum value of RPU is determined by following factors:

- ① Meets the condition that VOLMAX=0.4V, IOLMAX=3mA when the output is Low.

$$\frac{V_{CC}-V_{OL}}{R_{PU}} \leq I_{OL}$$

$$\therefore R_{PU} \geq \frac{V_{CC}-V_{OL}}{I_{OL}}$$

- ② VOLMAX=0.4V must be lower than the input Low level of the microcontroller and the EEPROM including the recommended noise margin of 0.1Vcc.

$$V_{OLMAX} \leq V_{IL}-0.1 V_{CC}$$

Examples: Vcc=3V, VOL=0.4V, IOL=3mA, the VIL of the controller and

According to ①

$$R_{PU} \geq \frac{3-0.4}{3 \times 10^{-3}}$$

$$\geq 867 [\Omega]$$

the EEPROM is VIL=0.3Vcc,

and

$$VOL=0.4 [V]$$

$$VIL=0.3 \times 3$$

$$=0.9 [V]$$

so that condition② is met

○SCL Pin Pull-up Resister

When SCL is controlled by the CMOS output the pull-up resistor at SCL is not required.

However, should SCL be set to Hi-Z, connection of a pull-up resistor between SCL and Vcc is recommended.

Several kΩ are recommended for the pull-up resistor in order to drive the output port of the microcontroller.

●Notes For Power Supply

Vcc rises through the low voltage region in which the internal circuit of the IC and the controller are unstable. Therefore, the device may not work properly due to an incomplete reset of the internal circuit. To prevent this, the device has a P.O.R. and LVcc feature. At power up, maintain the following conditions to ensure functions of P.O.R and LVcc.

1. "SDA="H" and "SCL="L" or "H".
2. Follow the recommended conditions of tR, tOFF, Vbot for the P.O.R. function during power up.

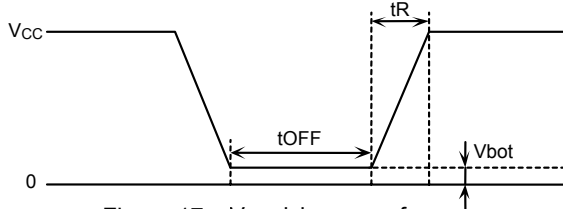

Recommended conditions of tR, tOFF, Vbot		
tR	tOFF	Vbot
Below 10ms	Above 10ms	Below 0.3V
Below 100ms	Above 10ms	Below 0.2V

Figure 17. Vcc rising wave from 0

3. Prevent SDA and SCL from being "Hi-Z".

In case conditions 1 and/or 2 cannot be met, take following actions:

A) If unable to keep condition 1 ( SDA is "Low" during power up):

→Control SDA, SCL to be "High" as shown in figure below.

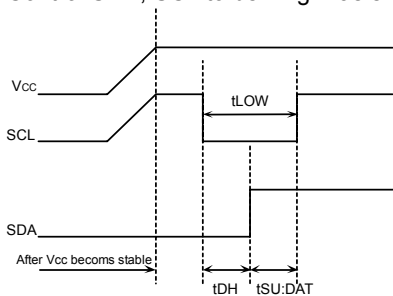

Figure 18. SCL="H" and SDA="L"

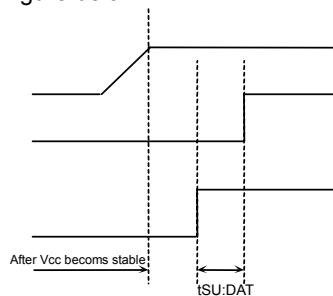

Figure 19. SCL="L" and SDA="L"

B) If unable to keep condition 2.

→After power becomes stable, execute software reset. (See Figure 13.)

C) If unable to keep both conditions 1 and 2.

→Follow the instruction A first, then the instruction B.

**●LVcc Circuit**

LVcc circuit inhibits write operation at low voltage, and prevents an inadvertent write. Write operation is inhibited below the LVcc voltage (Typ.=1.2V).

**●Vcc NOISE****○Bypass Condenser**

Noise and surges on power line may cause abnormal function. It is recommended that the bypass condensers (0.1μF) are attached on the Vcc and GND line beside the device. It is also recommended to attach bypass condensers on the board close to the connector.

**●Notes for Use**

- 1) Described numeric values and data are design representative values, and the values are not guaranteed.
- 2) We believe that application circuit examples are recommendable, however, in actual use, confirm characteristics further sufficiently. In the case of use by changing the fixed number of external parts, make your decision with sufficient margin in consideration of static characteristics and transition characteristics and fluctuations of external parts and our LSI.
- 3) Absolute maximum ratings  
If the absolute maximum ratings such as impressed voltage and operating temperature range and so forth are exceeded, LSI may be destructed. Do not impress voltage and temperature exceeding the absolute maximum ratings. In the case of fear exceeding the absolute maximum ratings, take physical safety countermeasures such as fuses, and see to it that conditions exceeding the absolute maximum ratings should not be impressed to LSI.
- 4) GND electric potential  
Set the voltage of GND terminal lowest at any action condition. Make sure that each terminal voltage is lower than that of GND terminal.
- 5) Heat design  
In consideration of permissible dissipation in actual use condition, carry out heat design with sufficient margin.
- 6) Terminal to terminal short circuit and wrong packaging  
When to package LSI onto a board, pay sufficient attention to LSI direction and displacement. Wrong packaging may destruct LSI. And in the case of short circuit between LSI terminals and terminals and power source, terminal and GND owing to foreign matter, LSI may be destructed.
- 7) Use in a strong electromagnetic field may cause malfunction, therefore, evaluated design sufficiently

**Status of this document**

The Japanese version of this document is formal specification. A customer may use this translation version only for a reference to help reading the formal version.

If there are any differences in translation version of this document formal version takes priority.

● Ordering Information

Product Code Description

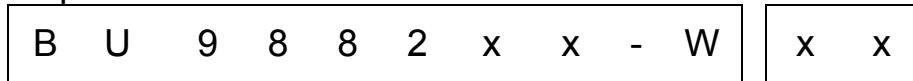

Package

- Blank :DIP14
- F :SOP14
- FV :SSOP-B14

Double Cell

Packaging and forming specification

- E2 : Embossed tape and reel  
(SOP14, SSOP-B14)
- None : Tube  
(DIP14)

● Lineup

Capacity	Package	
	Type	Quantity
2K	DIP14	Tube of 1000
	SOP14	Reel of 2500
	SSOP-B14	

●Physical Dimension Tape and Reel Information

DIP14

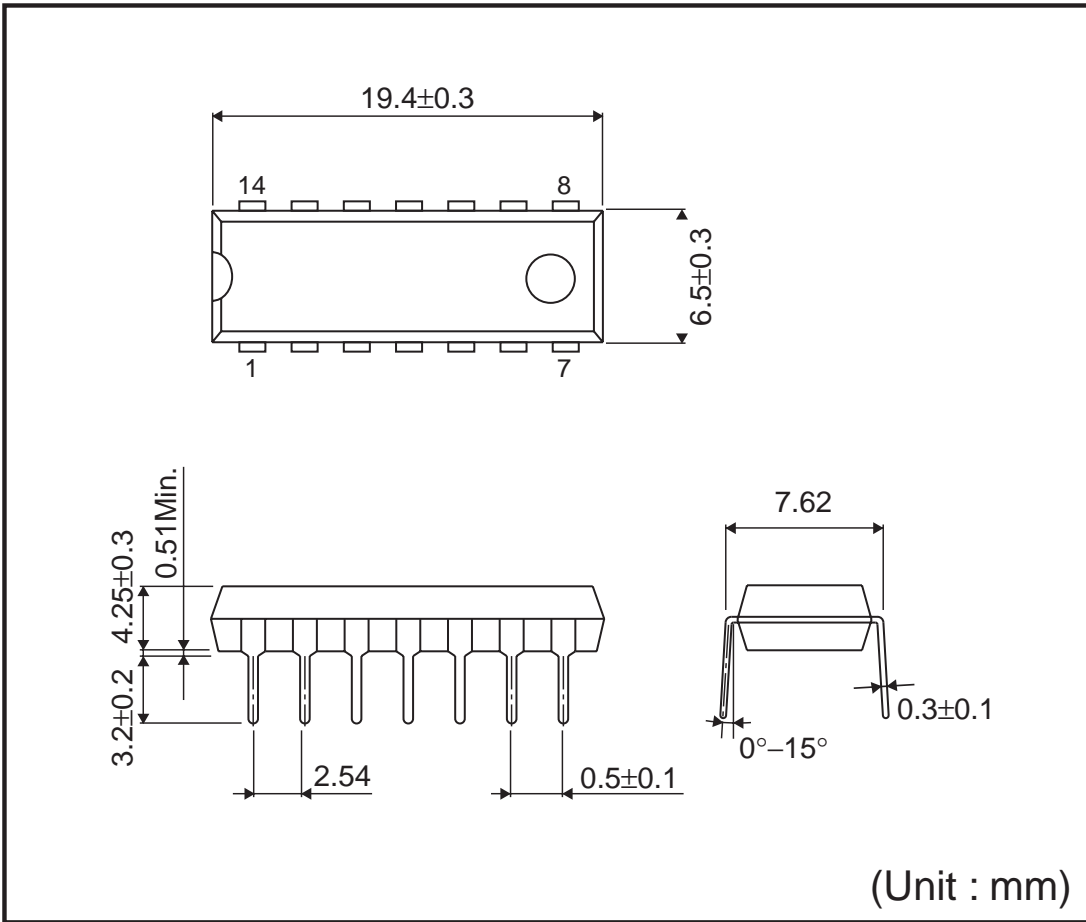

<Tape and Reel information>

Container	Tube
Quantity	1000pcs
Direction of feed	Direction of products is fixed in a container tube

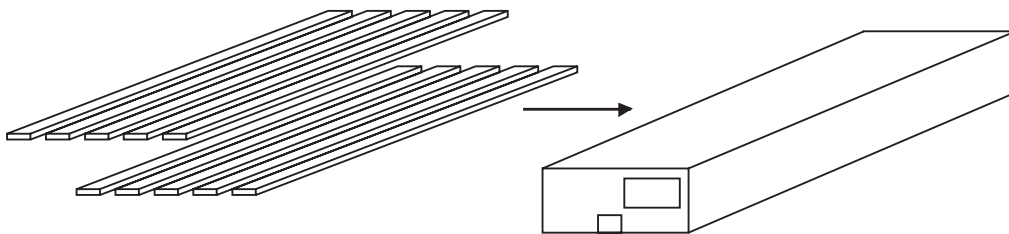

\*Order quantity needs to be multiple of the minimum quantity.

●Physical Dimension Tape and Reel Information - Continued

SOP14

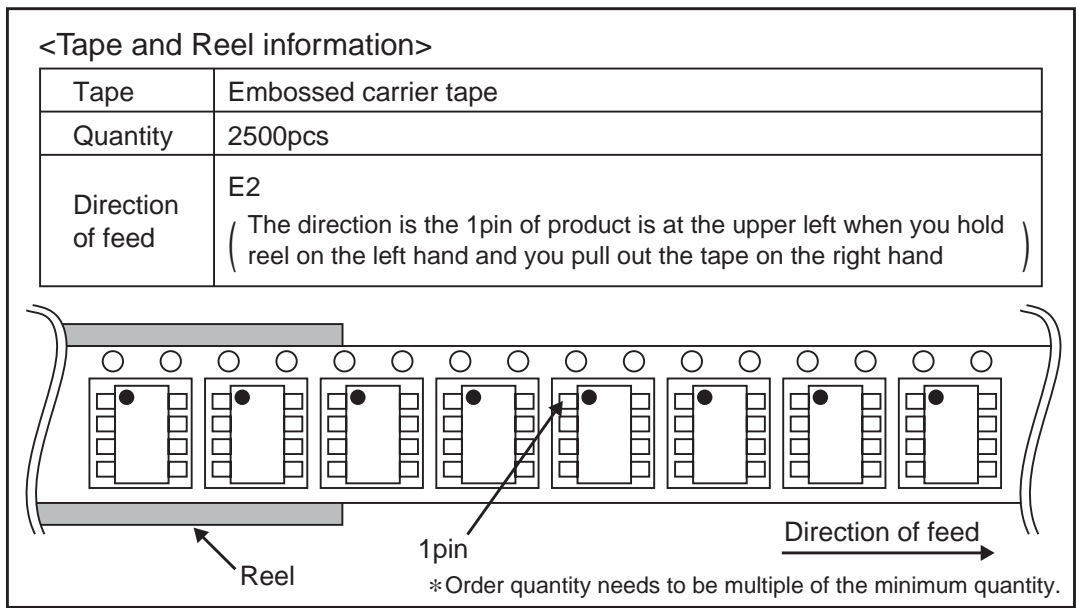
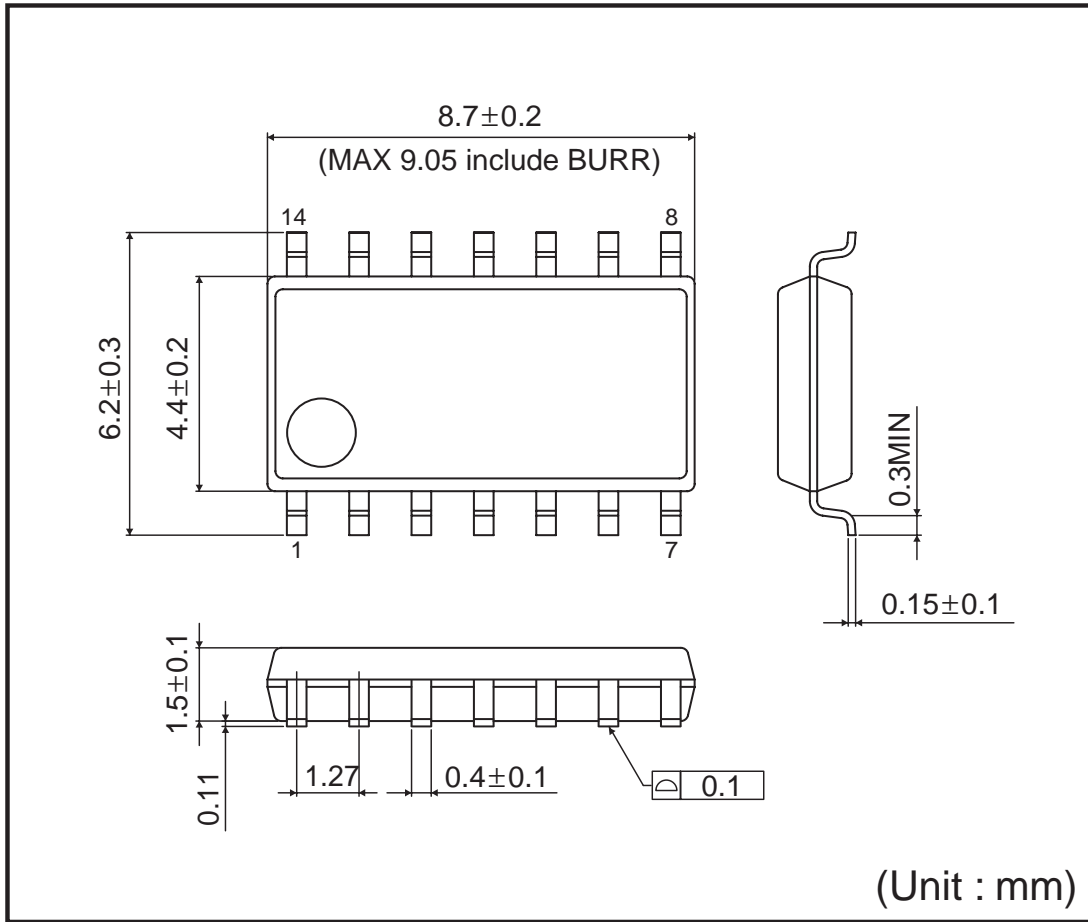

●Physical Dimension Tape and Reel Information - Continued

SSOP-B14

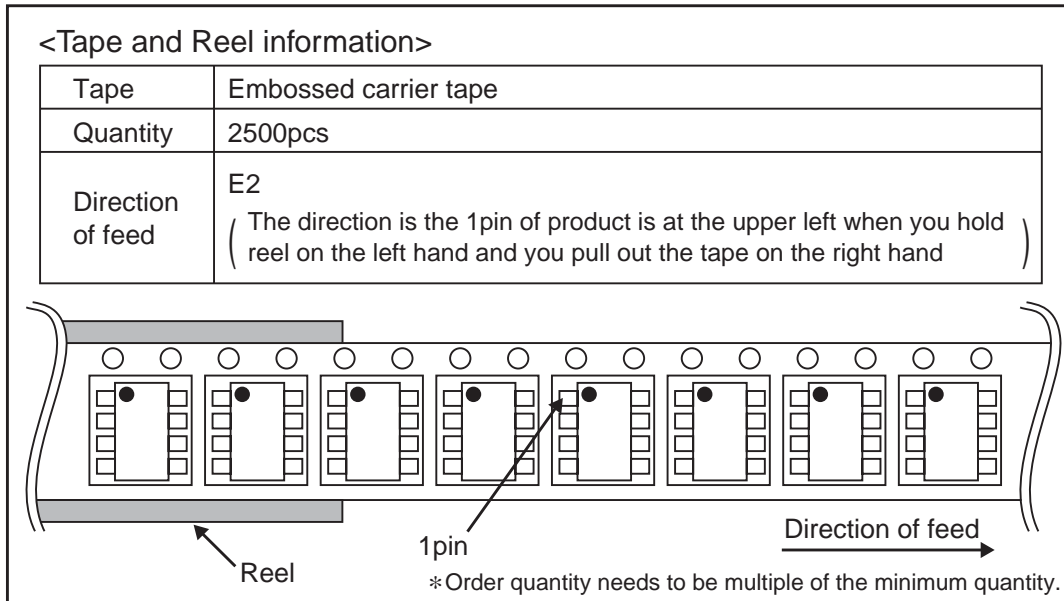
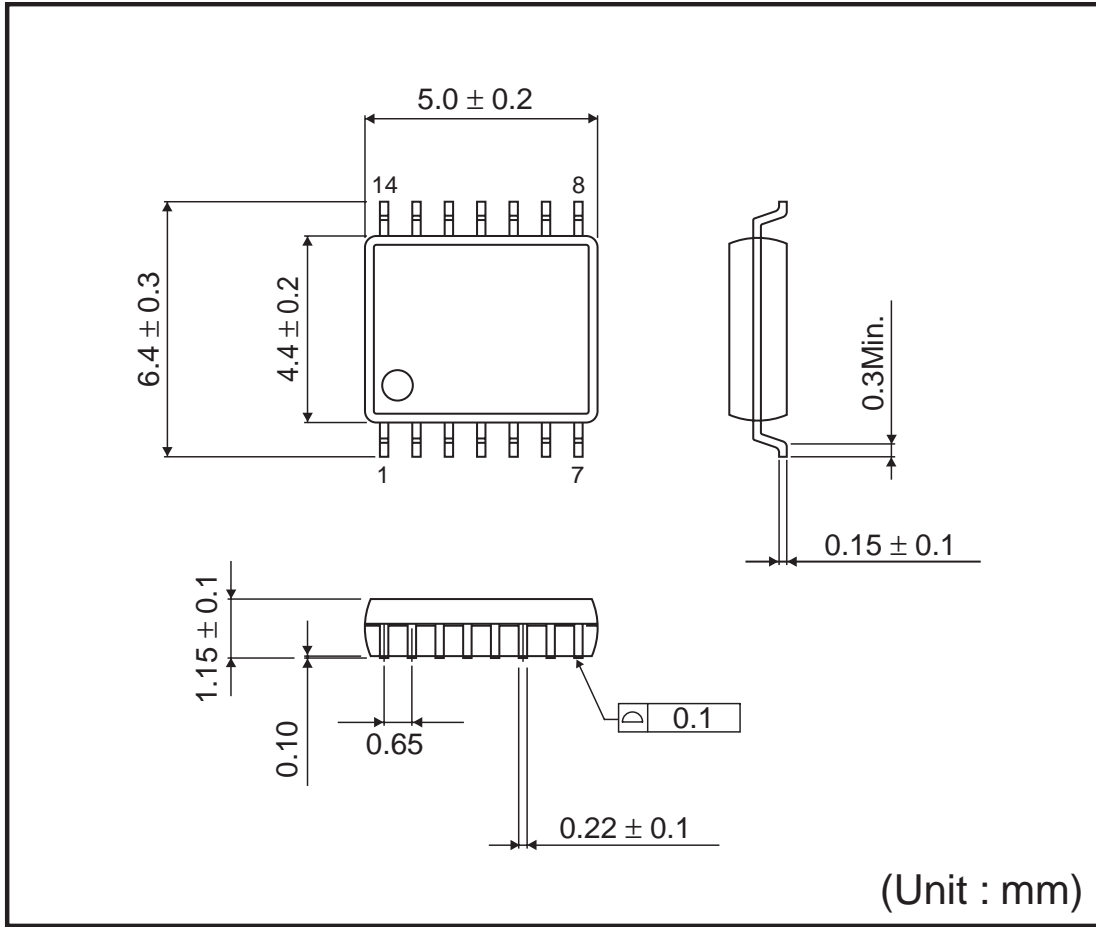

●Marking Diagrams

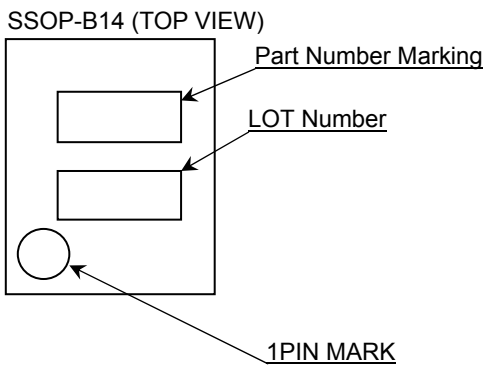
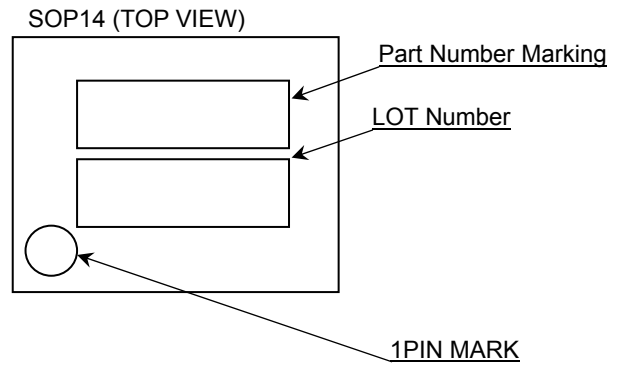
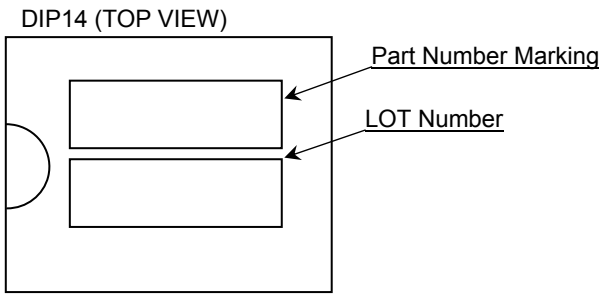

●Marking Information

Capacity	Product Name Marking	Package Type
2K	BU9882	DIP14
	BU9882	SOP14
	9882	SSOP-B14

●Revision History

Date	Revision	Changes
19.Jul.2012	001	New Release

# Notice

## ●General Precaution

- 1) Before you use our Products, you are requested to carefully read this document and fully understand its contents. ROHM shall not be in any way responsible or liable for failure, malfunction or accident arising from the use of any ROHM's Products against warning, caution or note contained in this document.
- 2) All information contained in this document is current as of the issuing date and subject to change without any prior notice. Before purchasing or using ROHM's Products, please confirm the latest information with a ROHM sales representative.

## ●Precaution on using ROHM Products

- 1) Our Products are designed and manufactured for application in ordinary electronic equipments (such as AV equipment, OA equipment, telecommunication equipment, home electronic appliances, amusement equipment, etc.). If you intend to use our Products in devices requiring extremely high reliability (such as medical equipment, transport equipment, traffic equipment, aircraft/spacecraft, nuclear power controllers, fuel controllers, car equipment including car accessories, safety devices, etc.) and whose malfunction or failure may cause loss of human life, bodily injury or serious damage to property ("Specific Applications"), please consult with the ROHM sales representative in advance. Unless otherwise agreed in writing by ROHM in advance, ROHM shall not be in any way responsible or liable for any damages, expenses or losses incurred by you or third parties arising from the use of any ROHM's Products for Specific Applications.
- 2) ROHM designs and manufactures its Products subject to strict quality control system. However, semiconductor products can fail or malfunction at a certain rate. Please be sure to implement, at your own responsibilities, adequate safety measures including but not limited to fail-safe design against the physical injury, damage to any property, which a failure or malfunction of our Products may cause. The following are examples of safety measures:
  - [a] Installation of protection circuits or other protective devices to improve system safety
  - [b] Installation of redundant circuits to reduce the impact of single or multiple circuit failure
- 3) Our Products are designed and manufactured for use under standard conditions and not under any special or extraordinary environments or conditions, as exemplified below. Accordingly, ROHM shall not be in any way responsible or liable for any damages, expenses or losses arising from the use of any ROHM's Products under any special or extraordinary environments or conditions. If you intend to use our Products under any special or extraordinary environments or conditions (as exemplified below), your independent verification and confirmation of product performance, reliability, etc. prior to use, must be necessary:
  - [a] Use of our Products in any types of liquid, including water, oils, chemicals, and organic solvents
  - [b] Use of our Products outdoors or in places where the Products are exposed to direct sunlight or dust
  - [c] Use of our Products in places where the Products are exposed to sea wind or corrosive gases, including Cl<sub>2</sub>, H<sub>2</sub>S, NH<sub>3</sub>, SO<sub>2</sub>, and NO<sub>2</sub>
  - [d] Use of our Products in places where the Products are exposed to static electricity or electromagnetic waves
  - [e] Use of our Products in proximity to heat-producing components, plastic cords, or other flammable items
  - [f] Sealing or coating our Products with resin or other coating materials
  - [g] Use of our Products without cleaning residue of flux (even if you use no-clean type fluxes, cleaning residue of flux is recommended); or Washing our Products by using water or water-soluble cleaning agents for cleaning residue after soldering
  - [h] Use of the Products in places subject to dew condensation
- 4) The Products are not subject to radiation-proof design.
- 5) Please verify and confirm characteristics of the final or mounted products in using the Products.
- 6) In particular, if a transient load (a large amount of load applied in a short period of time, such as pulse) is applied, confirmation of performance characteristics after on-board mounting is strongly recommended. Avoid applying power exceeding normal rated power; exceeding the power rating under steady-state loading condition may negatively affect product performance and reliability.
- 7) De-rate Power Dissipation (Pd) depending on Ambient temperature (Ta). When used in sealed area, confirm the actual ambient temperature.
- 8) Confirm that operation temperature is within the specified range described in the product specification.
- 9) ROHM shall not be in any way responsible or liable for failure induced under deviant condition from what is defined in this document.

● **Precaution for Mounting / Circuit board design**

- 1) When a highly active halogenous (chlorine, bromine, etc.) flux is used, the residue of flux may negatively affect product performance and reliability.
- 2) In principle, the reflow soldering method must be used; if flow soldering method is preferred, please consult with the ROHM representative in advance.

For details, please refer to ROHM Mounting specification

● **Precautions Regarding Application Examples and External Circuits**

- 1) If change is made to the constant of an external circuit, please allow a sufficient margin considering variations of the characteristics of the Products and external components, including transient characteristics, as well as static characteristics.
- 2) You agree that application notes, reference designs, and associated data and information contained in this document are presented only as guidance for Products use. Therefore, in case you use such information, you are solely responsible for it and you must exercise your own independent verification and judgment in the use of such information contained in this document. ROHM shall not be in any way responsible or liable for any damages, expenses or losses incurred by you or third parties arising from the use of such information.

● **Precaution for Electrostatic**

This Product is electrostatic sensitive product, which may be damaged due to electrostatic discharge. Please take proper caution in your manufacturing process and storage so that voltage exceeding the Products maximum rating will not be applied to Products. Please take special care under dry condition (e.g. Grounding of human body / equipment / solder iron, isolation from charged objects, setting of Ionizer, friction prevention and temperature / humidity control).

● **Precaution for Storage / Transportation**

- 1) Product performance and soldered connections may deteriorate if the Products are stored in the places where:
  - [a] the Products are exposed to sea winds or corrosive gases, including Cl<sub>2</sub>, H<sub>2</sub>S, NH<sub>3</sub>, SO<sub>2</sub>, and NO<sub>2</sub>
  - [b] the temperature or humidity exceeds those recommended by ROHM
  - [c] the Products are exposed to direct sunshine or condensation
  - [d] the Products are exposed to high Electrostatic
- 2) Even under ROHM recommended storage condition, solderability of products out of recommended storage time period may be degraded. It is strongly recommended to confirm solderability before using Products of which storage time is exceeding the recommended storage time period.
- 3) Store / transport cartons in the correct direction, which is indicated on a carton with a symbol. Otherwise bent leads may occur due to excessive stress applied when dropping of a carton.
- 4) Use Products within the specified time after opening a humidity barrier bag. Baking is required before using Products of which storage time is exceeding the recommended storage time period.

● **Precaution for Product Label**

QR code printed on ROHM Products label is for ROHM's internal use only.

● **Precaution for Disposition**

When disposing Products please dispose them properly using an authorized industry waste company.

● **Precaution for Foreign Exchange and Foreign Trade act**

Since our Products might fall under controlled goods prescribed by the applicable foreign exchange and foreign trade act, please consult with ROHM representative in case of export.

● **Precaution Regarding Intellectual Property Rights**

- 1) All information and data including but not limited to application example contained in this document is for reference only. ROHM does not warrant that foregoing information or data will not infringe any intellectual property rights or any other rights of any third party regarding such information or data. ROHM shall not be in any way responsible or liable for infringement of any intellectual property rights or other damages arising from use of such information or data.:
- 2) No license, expressly or implied, is granted hereby under any intellectual property rights or other rights of ROHM or any third parties with respect to the information contained in this document.

●Other Precaution

- 1) The information contained in this document is provided on an “as is” basis and ROHM does not warrant that all information contained in this document is accurate and/or error-free. ROHM shall not be in any way responsible or liable for any damages, expenses or losses incurred by you or third parties resulting from inaccuracy or errors of or concerning such information.
- 2) This document may not be reprinted or reproduced, in whole or in part, without prior written consent of ROHM.
- 3) The Products may not be disassembled, converted, modified, reproduced or otherwise changed without prior written consent of ROHM.
- 4) In no event shall you use in any way whatsoever the Products and the related technical information contained in the Products or this document for any military purposes, including but not limited to, the development of mass-destruction weapons.
- 5) The proper names of companies or products described in this document are trademarks or registered trademarks of ROHM, its affiliated companies or third parties.