

MODEL 7720 SERIES

Power Factor Correction Module

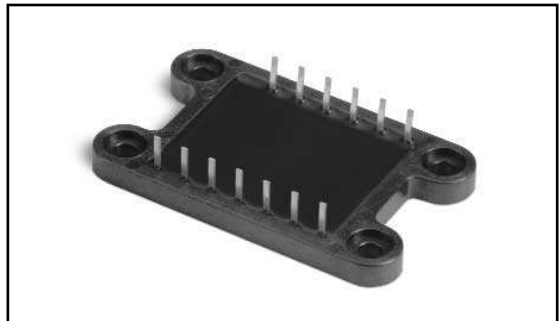

MODELS/RANGE

| | |
|---------|----------------------------|
| 7720-1A | 1,500 Watts / 3,000 Watts* |
| 7720-2A | 1,000 Watts / 2,250 Watts* |
| 7720-3A | 500 Watts / 1,500 Watts* |

FEATURES AND BENEFITS

- Module contains all power components necessary to provide power factor correction in a switching power supply.
 - Rectifier bridge
 - Ultrafast platinum output diode
 - 500V .1 Ω Max. FET (7720-1A)
- Provides optimum use of available line current
- Allows power supply to meet harmonic requirement
- Module design reduces cost of heat sink
- Saves significant space and assembly time
- Low cost
- Internal temperature sensing
- Replaces up to 10 each TO-220 or TO-247 discrete power semiconductors
- Custom module versions available to meet specific requirements such as:
 - Motor drives
 - Power servo amplifiers
 - Solenoid drivers
 - Solid state relays
 - 3 phase rectifier bridges

APPLICATIONS

Designed to optimally facilitate a boost type power factor correction (PFC) system for designs with up to 20 A rms input current.

Standard applications include switching power supplies from 500 watts to 3,000 watts with line voltages up to 300 V rms.

* Based on minimum line voltage of 84 V rms / 168 V rms.
Specifications subject to change without notice.

ELECTRICAL CHARACTERISTICS

| Parameter | Symbol | Conditions ¹ | 7720-X | Min. | Typ. | Max. | Units | | | |
|--------------------------------------|--------------|---|--------------------|--------------|--|-----------|-----------------|-----|---------------|---------|
| FET Drain Leakage Current | I_{DSS} | $V_{DS} = 500V, V_{GS} = 0V$ | -1 | | | 1.0 | mA | | | |
| | | | -2 | | | 750 | μA | | | |
| | | | -3 | | | 500 | μA | | | |
| On-State Voltage | $V_{DS(on)}$ | $I_{DS} = 28A, V_{GS} = 10V$ $I_{DS} = 21A$ $I_{DS} = 14A$ | -1 | | 2.2 | 2.9 | V | | | |
| | | | -2 | | 2.2 | 2.9 | V | | | |
| | | | -3 | | 2.2 | 2.9 | V | | | |
| Threshold Voltage | $V_{GS(th)}$ | $V_{DS} = 4V, I_{DS} = 1mA$ | -1,-2,-3 | 2.0 | 3.0 | 4.0 | V | | | |
| Gate Leakage Current | I_{GSS} | $V_{GS} = \pm 15V, V_{DS} = 0V$ | -1 | | | ± 2 | μA | | | |
| | | | -2 | | | ± 1.5 | μA | | | |
| | | | -3 | | | ± 1 | μA | | | |
| Diode Forward Voltage | V_{SD} | $I_{SD} = 50A, V_{GS} = 0V$ $I_{SD} = 37.5A$ $I_{SD} = 25A$ | -1 | | 0.95 | 1.5 | V | | | |
| | | | -2 | | 0.95 | 1.5 | V | | | |
| | | | -3 | | 0.95 | 1.5 | V | | | |
| Input Capacitance | C_{iss} | $V_{GS} = 0V, V_{DS} = 25V, f = 1.0MHz$ | -1 | | 12 | | nF | | | |
| | | | -2 | | 9 | | nF | | | |
| | | | -3 | | 6 | | nF | | | |
| Gate Resistor | R_G | | -1 | | 1.28 | | Ω | | | |
| | | | -2 | | 1.70 | | Ω | | | |
| | | | -3 | | 2.55 | | Ω | | | |
| Junction Temperature | T_j | | -1,-2,-3 | | | 150 | $^{\circ}C$ | | | |
| Thermal Resistance | R_{thjc} | | -1 | | 0.19 | | $^{\circ}C/W$ | | | |
| | | | -2 | | 0.25 | | $^{\circ}C/W$ | | | |
| | | | -3 | | 0.38 | | $^{\circ}C/W$ | | | |
| D1-D4 Reverse Leakage Current | I_R | $V_R = 600V$ | -1,-2,-3 | | 1 | 250 | μA | | | |
| | | | Forward Voltage | V_F | $I_F = 25A$ | -1,-2 | | 1.0 | 1.2 | V |
| | | | | | | -3 | | 1.0 | 1.2 | V |
| Junction Temperature | T_j | | -1,-2,-3 | | | 150 | $^{\circ}C$ | | | |
| | | | Thermal Resistance | R_{thjc} | | -1,-2 | | 1.3 | $^{\circ}C/W$ | |
| | | | | | | -3 | | 1.4 | $^{\circ}C/W$ | |
| D5 Forward Voltage | V_F | $I_F = 25A$ $I_F = 18A$ | -1,-2 | | 1.5 | 2.8 | V | | | |
| | | | -3 | | 1.5 | 2.8 | V | | | |
| | | | Forward Voltage | V_F | $I_F = 25A, t = 150^{\circ}C$ $I_F = 18A$ | -1,-2 | | 1.3 | 2.5 | V |
| -3 | | 1.3 | | | | 2.5 | V | | | |
| Reverse Leakage Current | I_R | $V_R = 600V$ | | | | -1,-2,-3 | | 1 | 500 | μA |
| Reverse Leakage Current | I_R | $V_R = 600V, t = 150^{\circ}C$ | -1,-2,-3 | | 0.3 | 1.5 | mA | | | |
| Reverse Recovery Time | t_{rr} | $I_F = 1.0A, di/dt = 100A/\mu s$ | -1,-2,-3 | | 30 | 40 | ns | | | |
| Reverse Recovery Time | t_{rr} | $I_F = 25A, di/dt = 100A/\mu s$ | -1,-2,-3 | | 40 | 45 | ns | | | |
| Junction Temperature | T_j | | -1,-2,-3 | | | 175 | $^{\circ}C$ | | | |
| Thermal Resistance | R_{thjc} | | -1,-2 | | 1.3 | | $^{\circ}C/W$ | | | |
| | | | -3 | | 1.4 | | $^{\circ}C/W$ | | | |
| TH1 Resistance | R_{25} | $I = 1mA$ | | 22.5 | 25 | 27.5 | K Ω | | | |
| | | | Resistance Ratio | R_7/R_{25} | $t = 80$ | | 0.126 | | | |
| | | | | | 0.0916 | | | | | |
| | | | | | 0.0679 | | | | | |
| | | | | | 0.0511 | | | | | |
| Dissipation Constant | P_D | | | 1.0 | | | mW/ $^{\circ}C$ | | | |
| Thermal Time Constant | t | | | | | 10 | sec | | | |

1 - $T_{Case} = 25^{\circ}C$ unless otherwise specified.

OUTLINE DIMENSIONS (Inch)

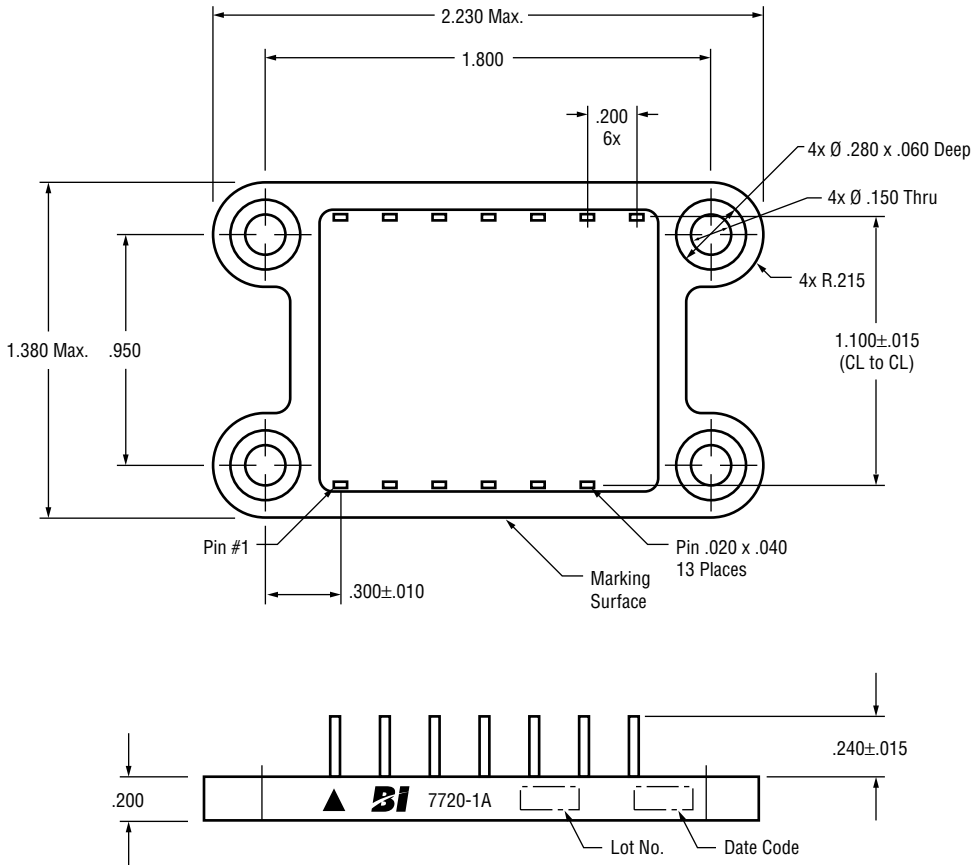

ORDERING INFORMATION

